

## **Legislative Council Panel on Public Service**

### **Staffing Requirement for Secretariat Support to the Commission on Strategic Development and Research Activities of the Central Policy Unit**

#### **INTRODUCTION**

This paper briefs Members on the proposal to create three permanent directorate posts upon the lapse of the relevant supernumerary posts in the Central Policy Unit (CPU) on 1 March 2001. The arrangement will enable CPU to maintain its on-going research and liaison activities and continue to provide secretariat service to the Commission on Strategic Development (CSD).

#### **BACKGROUND**

##### **Role and Structure of CPU**

2. CPU has three main streams of work, viz. the coordination of the annual Policy Address exercise, the provision of secretariat support to the CSD and the analysis of major and important policy issues, with a view to providing its three clients, i.e. the Chief Executive (CE), the Chief Secretary for Administration and the Financial Secretary, an alternative source of advice. On the last task, the Unit undertakes examination of complex policy issues, particularly those that straddle several policy bureaux, analyses options and recommends practical solutions. Before coming up with advice, the Unit consults widely with business and professional sectors, political organisations, special interest groups, the academic community, and in particular, its network of part-time members.

3. CPU's organisation is designed to allow maximum flexibility and speed in responding to requests for analysis and recommendations. As at 1 January 2001, the Unit has 33 civil service posts and 6 non-civil service appointments. The non-civil service appointments include the

positions for Head, CPU (H, CPU), three full-time Members and two Researchers. As for civil service posts, four are at Directorate level. The rest consists of administrative, statistical, executive, clerical and secretarial grade officers. The existing organisation structure of CPU is at **Enclosure 1**.

### **Review of Staffing**

4. Among the Directorate posts in the Unit, three are supernumerary posts created in 1998 for a period of 3 years and will lapse on 1 March 2001 -

- (a) one Administrative Officer Staff Grade B (AOSGB) (D3) post (i.e. Secretary, CSD);
- (b) one Government Town Planner (GTP) (D2) post (i.e. GTP(CSD)); and
- (c) one Administrative Officer Staff Grade C (AOSGC) (D2) post (i.e. Research Director).

CPU has conducted a review of its staffing requirement having regard to its workload and mandate, and concluded that there is a need to retain the three supernumerary directorate posts on a permanent basis.

### **PROPOSAL**

5. H, CPU proposes to create the following three permanent posts in CPU with effect from 1 March 2001 -

- (a) one post of AOSGB (D3) and one post of GTP (D2) to continue to provide secretariat support for the CSD; and
- (b) one post of AOSGC (D2) to continue to perform some core research, liaison and administrative duties in CPU.

6. Since the three new permanent posts will in effect only be replacing three existing supernumerary posts, there will be no net increase

in the number of Directorate posts in CPU upon the implementation of the proposal.

## **JUSTIFICATION**

### *Secretariat Support for CSD*

7. The CSD was set up in February 1998 to advise the CE on Hong Kong's long term development needs and goals. Its mandate is to conduct reviews and studies on Hong Kong's economy, human resources, education, housing, land supply, environmental protection and relations with the Mainland of China. The Commission aims to ensure that Hong Kong's resources are well-used, that Hong Kong keeps up with world trends in competitive terms and that the vitality of Hong Kong's economic development is maintained.

8. The CSD is chaired by the CE and its membership comprises senior government officials as well as prominent private sector figures from different fields. CPU has been tasked to provide the secretariat support for the CSD since its establishment. The two posts mentioned in para. 4(a) & (b) above were created on a supernumerary basis in 1998 to serve the CSD. They were created for an initial period of three years to allow a reasonable period for the new organisational structure to run-in and for CPU to review the continued need for the posts in the light of experience.

9. Given its mandate to deliberate on the future development of Hong Kong, the CSD will exist on a long-term basis. The current members of the CSD have just been re-appointed for another two years term until 2002. In accordance with its Term of Reference, the CSD will have to continue monitoring Hong Kong's changing needs and to fine-tune our development strategies. The CSD Secretariat will provide an interface for exchange between the Commission and the rest of the Government as well as the general public. To cater for the on-going needs of the CSD, H, CPU considers it necessary to create two permanent posts upon the lapse of the two supernumerary posts.

*Creation of a permanent AOSGB (D3) post upon the lapse of a supernumerary AOSGB (D3) post*

10. The supernumerary AOSGB post was designated as the Secretary to the CSD when the Commission was created in 1998. Since its establishment, the CSD has relied heavily on the Secretary to steer and conduct the necessary research, to collect and analyse important information and to prepare papers for deliberation of the Commission.

11. The Secretary to the CSD will continue to be heavily engaged in managing research projects, liaising and coordinating with different parties inside and outside of the Government, as well as supervising the day to day operation of the CSD Secretariat. In the coming years, further research will be carried out on how the links with the Mainland, a strategic theme identified by the Commission, can be strengthened in order to achieve Hong Kong's long-term vision to become Asia's world City and a major city in China. The implications of future development of Shanghai, the Western Region and the Pearl River Delta Region to Hong Kong are also amongst the major issues to be examined. These research projects will straddle different streams of expertise inside and outside of the Government. In view of the complexity and level of difficulties of the studies, the requirement for coordinating inputs from concerned parties as well as the need for frequent liaison with the CSD members, we consider it appropriate for the Secretary to the CSD to continue to be pitched at AOSGB (D3) level. The job description of the post is at **Enclosure 2**.

*Creation of a permanent GTP (D2) post upon the lapse of the supernumerary GTP (D2) post*

12. The work of the CSD involves long term strategic planning for Hong Kong and many other planning related issues. To support its work on an on-going basis, it is necessary to retain the existing supernumerary GTP post in CPU on a permanent basis. The GTP will continue to provide the Secretary of CSD with professional and technical support in overseeing future consultancy projects of CSD. The GTP will also assist the Secretary in studying the global, regional and Mainland development trends which have significant impact on Hong Kong. In addition, the GTP will liaise with other government bureaux and departments, in particular the Planning Department, in providing input into the strategic development framework of CSD, as well as ensuring coherence between

the CSD's work and the Planning Department's territorial planning process. The work is complex and covers a very wide scope that requires the expertise and judgement of an experienced planner with strategic policy perspective . Thus, we consider that it is necessary to continue pitching this post at GTP (D2) level. The job description of the permanent GTP post is at **Enclosure 3**.

*Creation of a permanent AOSGC (D2) post upon the lapse of a supernumerary AOSGC (D2) post*

13. The supernumerary AOSGC post was designated as Research Director (RD) when it was created in 1998. The schedule of work of the post includes research, liaison and administrative duties for the Unit. On research, the RD plays the role of project manager for the studies undertaken by CPU. The studies usually straddle a number of policy areas and include various economic, social and political issues. It is also the RD's task to coordinate research work and input from other staff of CPU when working on more complex projects. When conducting research, the RD has to communicate with different government bureaux and departments, local and overseas think tanks, academic institutions and research agencies.

14. The RD's other areas of work relate to the CPU Part-time Members Programme, the organisation of public seminars and the Policy Address exercise. The CPU's Part-time Members Programme is a channel for CPU to tap the expertise and views of the private sector. As at 1 January 2001, CPU has a total of 27 Part-time Members. They have different expertise and come from various professional fields. While the Deputy Head (DH) of CPU oversees the Programme, the RD is responsible for its day to day operation. The RD assists the DH to set and prioritise topics for Part-time Members' discussion, to line up a good mix of officials and experts to participate in the discussions, to conduct essential background research, and collate and analyse the views raised at the discussions for submission to CPU's clients.

15. As for CPU's public seminars and conferences, the RD is responsible for identifying and selecting topics, liaising with potential contributors and working out the focus of discussion with the speakers.

There has been a very enthusiastic response from the public to such seminars. The average attendance is over two hundred people. These seminars and conferences are a useful way to collect diverse views on the issues in question.

16. The preparation of the Policy Address and the monitoring of the follow-up to the announced policy commitments is a year-round exercise for CPU. The role of the RD in this exercise is to assist the H and DH, CPU to gather input from relevant parties inside and outside of Government for the Policy Address, and to undertake other supportive research and administrative follow-up work.

17. The policy research, public seminars, Part-time Members Programme and preparation for the annual Policy Address are all recurrent activities of the CPU. Given the important role played by the RD in providing research and administrative support to these activities which demands input at policy level, it is considered necessary to make the supernumerary RD post permanent. As the job requires frequent liaison with experts in other think tanks and academia, as well as senior government officials in government bureaux and departments, it is considered appropriate to continue to pitch the post at the ranking of AOSGC (D2). The job description of the RD post is at **Enclosure 4**.

-----

### **Alternatives**

18. H, CPU has considered the feasibility of redeploying other staff to take up the duties now performed by the Secretary to the CSD, GTP and RD. However, the other directorate staff of the Unit are all fully engaged and have no capacity to absorb the huge workload. The need for the directorate steer from the Secretary for the work of CSD is essential, and there are no other staff in CPU who can provide the professional support now rendered by the GTP. For the RD, there is not another post of comparative rank in the CPU which can absorb the duties. To assign the responsibilities of the above posts to other staff of the Unit not pitching at the appropriate levels will adversely affect the quality of the research work of CPU and the efficiency and effectiveness of the secretariat support for the CSD. Moreover, given the recurrent nature of the duties and the need to handle confidential information in performing the relevant task,

contracting-out of the jobs is considered not appropriate. H, CPU therefore sees no alternative to the present proposal.

### **THE WAY FORWARD**

19. The proposal will be submitted to the Establishment Subcommittee on 17 January 2001 for recommendation to the Finance Committee for approval.

Central Policy Unit  
January 2001





Existing Organisation of the Central Policy Unit

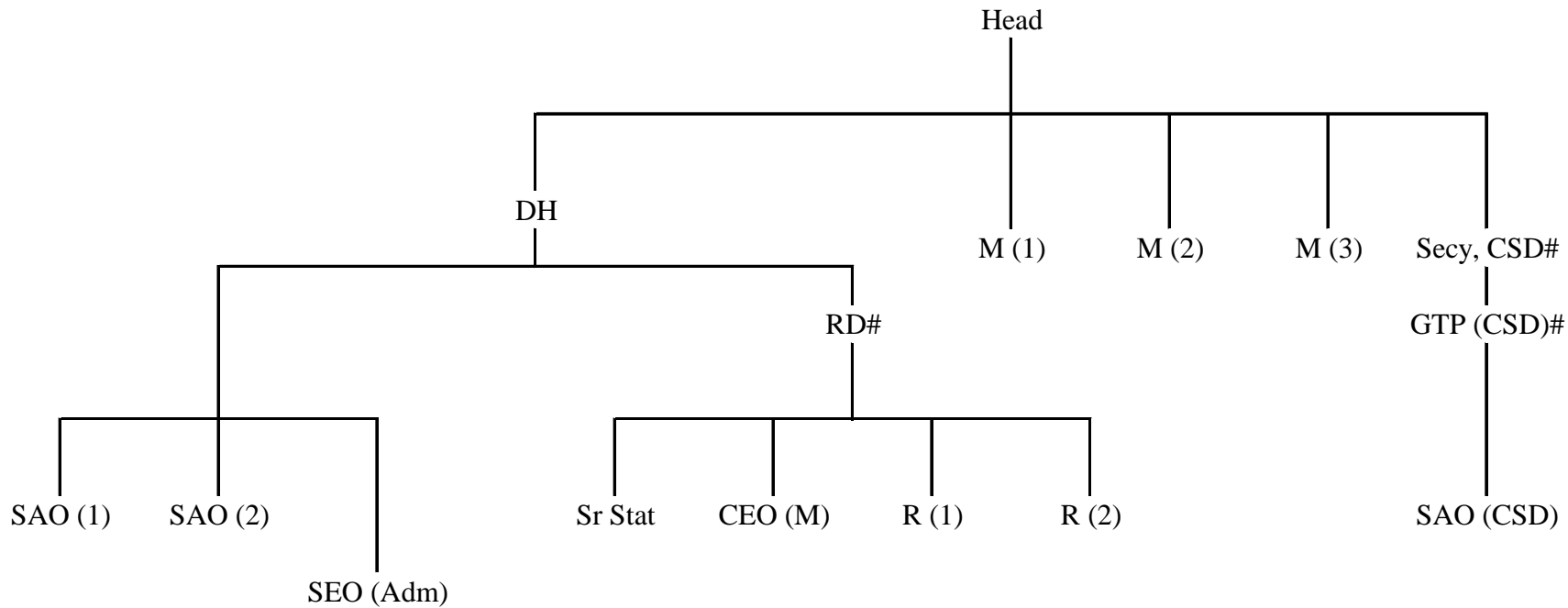

LEGEND

DH Deputy Head

M Member

Secy, CSD Secretary, Commission on Strategic Development

RD Research Director

GTP Government Town Planner

SAO Senior Administrative Officer

Sr Stat Senior Statistician

R Researcher

CEO (M) Chief Executive Officer (Members)

SEO (Adm) Senior Executive Officer (Administration)

(CSD) (Commission on Strategic Development)

# Supernumerary Post

**Job Description for  
Secretary, Commission on Strategic Development, Central Policy Unit  
(Administrative Officer Staff Grade B)**

Main duties and responsibility

- (1) Oversee the administration of the Secretariat of the Commission on Strategic Development;
- (2) provide support service to the Commission, particularly in monitoring Hong Kong's strategic development needs;
- (3) prepare briefs and research papers on strategic development for discussion by the Commission;
- (4) manage the consultancy projects initiated by the Commission and monitor their progress;
- (5) liaise with government departments and outside organisations in co-ordinating relevant issues for discussion by the Commission; and
- (6) undertaking any specific tasks as directed by the Commission.

**Job Description for Government Town Planner,  
Commission on Strategic Development,  
Central Policy Unit  
(Government Town Planner)**

Main duties and responsibility

- (1) Assist the Secretary to the Commission in preparing consultancy briefs and papers to facilitate the conduct of consultancy projects initiated by the Commission on Strategic Development;
- (2) assist the Secretary to the Commission in monitoring the progress of consultancy projects and provide steer to consultants, in particular, on planning related issues;
- (3) assist the Secretary to the Commission in preparing briefs and research papers to facilitate discussion at committees set up under the Commission;
- (4) assist the Secretary to the Commission in obtaining input from within and outside the Government for deliberation by the Commission;
- (5) assist in liaising with interested parties outside the Government, in respect of the studies initiated by the Commission; and
- (6) undertake any specific tasks as directed by the Commission.

**Job Description for Research Director,  
Central Policy Unit  
(Administrative Officer Staff Grade C)**

Main duties and responsibility

- (1) Act as project manager for research projects assigned to him by the Head and Deputy Head of the Unit, and liaise as necessary with parties inside and outside of the Government for views and inputs;
- (2) organise conferences and workshops with participation from overseas and local academia, professionals and members of the Unit, with a view to gathering views and recommendations on specific policy areas and gaining insight from overseas experience in the relevant field;
- (3) assist the Deputy Head of the Unit in managing the Part-time Members programme;
- (4) support the Head and the Deputy Head of the Unit in gathering inputs for the Policy Address from parties inside and outside of the Government and undertake supportive research and administrative duties;
- (5) maintain liaison contact with overseas think tanks and research centres; and
- (6) oversee the work of the Statistical Section of the Unit, in providing necessary statistical information for the conduct of research in the Unit.