

IMPORTANT

1. These Guidelines come into operation on _____ 2004 and will apply to all Legislative Council general elections and by-elections conducted under the Legislative Council Ordinance (Cap 542).
2. In these Guidelines, “he” means “he” or “she” as far as the context permits.
3. The law stated in these Guidelines is that prevailing as at the date of publication.
4. All specified forms referred to in these Guidelines are obtainable from the Registration and Electoral Office, tel: 2891 1001; fax: 2891 1180; e-mail: eacenq@reo.gov.hk, and its website at <http://www.info.gov.hk/reo>.
5. Electioneering, campaigning and canvassing activities referred to in these Guidelines include any positive and negative campaigning conducted for the purpose of promoting or prejudicing a candidate or candidates at the election.

2004 LEGISLATIVE COUNCIL ELECTION

Key Information

- (1) Polling Date : 12 September 2004
- (2) Polling Hours : 7:30 am to 10:30 pm
- (3) Deadline to submit : Not later than 1 April 2004
Application for Registration
of Names and Emblems
- (4) Period to submit : 19 March to 21 July 2004
Application for
Nominations Advisory
Committee's Service by
Candidate
- (5) Nomination Period of : 22 July to 4 August 2004
Candidature
- (6) Period to submit Request : 22 July to 4 August 2004
for Printing of Particulars
Relating to Candidates on
Ballot Papers by Candidate
- (7) Chairman's Briefing for : 7 August 2004
Candidates
- (8) Maximum Scale of Election : Geographical Constituency Election
Expenses
- | | |
|--------------------------|-------------|
| (a) Hong Kong Island | \$2,000,000 |
| (b) Kowloon East | \$1,500,000 |
| (c) Kowloon West | \$1,500,000 |
| (d) New Territories East | \$2,500,000 |
| (e) New Territories West | \$2,500,000 |

Functional Constituency Election

- | | |
|--|-----------|
| (a) Heung Yee Kuk,
Agriculture and
Fisheries, Insurance, or
Transport | \$100,000 |
| (b) Constituency (other than
those in (a) above) with
not more than 5,000
registered electors | \$160,000 |
| (c) Constituency with 5,001
to 10,000 registered
electors | \$320,000 |
| (d) Constituency with over
10,000 registered
electors | \$480,000 |
-
- | | | |
|--|---|----------------------------------|
| (9) Deadline to remove all
Election Advertisements on
display | : | Not later than 19 September 2004 |
| (10) Submission of Return and
Declaration of Election
Expenses and Donations by
Candidate | : | Not later than 16 November 2004 |
| (11) Submission of Claim for
Financial Assistance by
Candidate | : | Not later than 16 November 2004 |
| (12) Deadline to lodge Election
Petition | : | Not later than 17 November 2004 |

ABBREVIATIONS

AR, ARs	authorised representative, authorised representatives
ARO, AROs	Assistant Returning Officer, Assistant Returning Officers
Cap	Chapter of the Laws of Hong Kong
CE	Chief Executive
CEEEO	Chief Executive Election Ordinance (Cap 569)
CEO	Chief Electoral Officer
DAS	Director of Accounting Services
DC	District Council
DCO	District Councils Ordinance (Cap 547)
EA, EAs	election advertisement, election advertisements
EAC	Electoral Affairs Commission
EAC (EP) (LC) Reg	Electoral Affairs Commission (Electoral Procedure) (Legislative Council) Regulation
EAC (FA) (APP) Reg	Electoral Affairs Commission (Financial Assistance for Legislative Council Elections) (Application and Payment Procedure) Regulation
EAC (NAC) (LC) Reg	Electoral Affairs Commission (Nominations Advisory Committees) (Legislative Council) Regulation

EAC (ROE) (FCSEC) Reg	Electoral Affairs Commission (Registration) (Electors for Functional Constituencies) (Voters for Subsectors) (Members of Election Committee) (Legislative Council) Regulation
EAC (ROE) (GC) Reg	Electoral Affairs Commission (Registration of Electors) (Legislative Council Geographical Constituencies) (District Council Constituencies) Regulation
EACO	Electoral Affairs Commission Ordinance (Cap 541)
EC	Election Committee
ECICO	Elections (Corrupt and Illegal Conduct) Ordinance (Cap 554)
ERO	Electoral Registration Officer
FC, FCs	functional constituency, functional constituencies
HKSAR	Hong Kong Special Administrative Region
HKSA	Hong Kong Society of Accountants
GC, GCs	geographical constituency, geographical constituencies
GC list, GC lists	list(s) of candidate(s) in a geographical constituency election
ICAC	Independent Commission Against Corruption
LegCo	Legislative Council
LCO	Legislative Council Ordinance (Cap 542)

LegCo Subscribers & Deposit Reg	Legislative Council (Subscribers and Election Deposit for Nomination) Regulation
MAC, MACs	Mutual Aid Committee, Mutual Aid Committees
NAC, NACs	Nominations Advisory Committee, Nominations Advisory Committees
NCZ	no canvassing zone
NSZ	no staying zone
PCBP (LC) Reg	Particulars Relating to Candidates on Ballot Papers (Legislative Council) Regulation
POBO	Prevention of Bribery Ordinance (Cap 201)
printing details	name and address of the printer, date of printing and number of copies printed
PRO	Presiding Officer
REO	Registration and Electoral Office
RO, ROs	Returning Officer, Returning Officers
S, s, Ss, ss	section, sections
SFC, SFCs	special functional constituency, special functional constituencies
VREO	Village Representative Election Ordinance (Cap 576)

CONTENTS

	<u>Page</u>
CHAPTER 1 INTRODUCTION	1
Part I : The Legislative Council	1
Part II : The Guidelines	5
Part III : Sanction	6
CHAPTER 2 GEOGRAPHICAL CONSTITUENCIES	8
Part I : Description	8
Part II : Registration of Electors	9
Part III : The Voting System	16
CHAPTER 3 FUNCTIONAL CONSTITUENCIES	22
Part I : Composition	22
Part II : Registration of Electors	22
Part III : The Voting Systems	31
CHAPTER 4 NOMINATION OF CANDIDATES	35
Part I : Qualification and Disqualification for Nomination	35
Part II : Nominations Advisory Committees	39
Part III : When and How to Nominate	42
Part IV : Election Deposit	47
Part V : Validity of Nominations	49
Part VI : Withdrawal from Candidature	52
Part VII : Notice of Nomination	53
Part VIII : Particulars Relating to Candidates on Ballot Papers	53
Part IX : Publicity	60

CHAPTER 5	POLLING AND COUNTING ARRANGEMENTS	62
Part I	: Before the Poll	62
Part II	: Inside the Polling Station	66
Part III	: Outside the Polling Station	67
Part IV	: Admission to the Polling Station	69
Part V	: Conduct inside the Polling Station	71
Part VI	: Close of Poll	79
Part VII	: The Count	82
Part VIII	: Declaration of Result	94
Part IX	: Disposal of Documents	95
CHAPTER 6	ELECTION PETITIONS	97
Part I	: Grounds for Lodging an Election Petition	97
Part II	: Who could, and when to, Lodge Election Petitions	98
CHAPTER 7	APPOINTMENT AND ROLES OF ELECTION AGENT, ELECTION EXPENSE AGENTS, POLLING AGENTS AND COUNTING AGENTS	99
Part I	: General	99
Part II	: Types and Numbers of Agents	99
Part III	: Qualifications of Agents	100
Part IV	: Civil Servants Acting as Agents	100
Part V	: Election Agent	101
Part VI	: Election Expense Agents	104
Part VII	: Polling Agents	107
Part VIII	: Counting Agents	120

CHAPTER 8	ELECTION ADVERTISEMENTS	124
Part I	: What Constitutes an Election Advertisement	124
Part II	: Period and Area of Display	129
Part III	: Allocation of Designated Spots	134
Part IV	: Conditions and Limitations on Display	138
Part V	: Serial numbering, Declarations and Copies	140
Part VI	: Requirements relating to Printed Election Materials	145
Part VII	: Non-Compliance and Consequences	146
Part VIII	: Advertisements of Political, Professional/Trade Bodies or Other Organisations	148
Part IX	: Free Postage for Election Advertisements	149
CHAPTER 9	ELECTION MEETINGS	156
Part I	: General	156
Part II	: Notification to the Police	157
Part III	: Mobile Exhibitions	164
Part IV	: Fund Raising Activities at Election Meetings	165
CHAPTER 10	ELECTIONEERING AT THE LIVING OR WORKING PLACES OF ELECTORS, PREMISES OF ORGANISATIONS TO WHICH ELECTORS BELONG AND BUILDINGS WHICH ELECTORS FREQUENT	166
Part I	: General	166
Part II	: Rights of Tenants and Owners	167
Part III	: Decision to Allow or Disallow Electioneering	168
Part IV	: Respect for the Decision and Privacy	174
Part V	: Other Related Premises	176

Part VI	:	Notification of Decision	178
Part VII	:	Identification of Canvassers	179
Part VIII	:	Sanction	179
CHAPTER 11		ELECTION BROADCASTING, MEDIA REPORTING AND ELECTION FORUMS	181
Part I	:	General	181
Part II	:	Electioneering on TV and Radio	181
Part III	:	Advertising through the Print Media	184
Part IV	:	Election Forums	185
Part V	:	Sanction	186
CHAPTER 12		USE OF SOUND AMPLIFYING DEVICE AND BROADCASTING VANS	187
Part I	:	General	187
Part II	:	Use of Loudspeakers and Broadcasting Vans	187
Part III	:	Sanction	189
CHAPTER 13		ELECTIONEERING ACTIVITIES CONDUCTED IN SCHOOLS OR PARTICIPATED BY SCHOOL PUPILS	191
Part I	:	General	191
Part II	:	School Pupils	191
Part III	:	Electioneering Activities in Schools	193
Part IV	:	Sanction	194
CHAPTER 14		PROHIBITION AGAINST CANVASSING ACTIVITIES OUTSIDE POLLING STATIONS	195
Part I	:	General	195
Part II	:	Declaration of a No Canvassing Zone and No Staying Zone	195

Part III	: Conduct inside the No Canvassing Zone and No Staying Zone	197
Part IV	: Penalty	199
CHAPTER 15	EXIT POLL	200
Part I	: General	200
Part II	: Conduct of Exit Polls	200
Part III	: Secrecy of the Vote	202
Part IV	: Identification of Interviewers	202
Part V	: Sanction	203
CHAPTER 16	ELECTION EXPENSES AND DONATIONS	204
Part I	: What constitutes Election Expenses	204
Part II	: Who may incur Election Expenses and their Limit	207
Part III	: Donations	209
Part IV	: Return and Declaration of Election Expenses and Donations	212
Part V	: Advance Return of Donations	214
Part VI	: Financial Assistance	214
Part VII	: Special Features Applicable to the List of Candidates in a Geographical Constituency Election	220
Part VIII	: Enforcement and Penalty	223
CHAPTER 17	CORRUPT AND ILLEGAL CONDUCT	227
Part I	: General	227
Part II	: Corrupt Conduct relating to Nomination and Withdrawal of Candidates	228
Part III	: Illegal Conduct relating to Electioneering	229
Part IV	: Corrupt and Illegal Conduct relating to Electioneering and Voting	233

Part V	: Corrupt and Illegal Conduct relating to Election Expenses and Donations	235
Part VI	: Power of Court to Excuse Innocent Acts	235
Part VII	: Non-Compliance with the Law and Sanction	236
CHAPTER 18	NAMEDROPPING	239
CHAPTER 19	ATTENDANCE OF PUBLIC FUNCTIONS BY BOTH GOVERNMENT OFFICIALS AND CANDIDATES	245
Part I	: General	245
Part II	: Attendance of Public Functions by Government Officials	246
Part III	: Attendance of Public Functions by Candidates	247
Part IV	: Principal Officials	248
CHAPTER 20	COMPLAINTS PROCEDURE	249
Part I	: General	249
Part II	: To whom a Complaint may be Made	249
Part III	: Time and Procedure for Making Complaint	250
Part IV	: Complaints inside a Polling Station	251
Part V	: The Processing of Complaint	252
Part VI	: Electoral Affairs Commission's Report on Complaints	254
Part VII	: Obligations of the Returning Officer, the Presiding Officer and the Registration and Electoral Office	254
Part VIII	: Sanction for False Complaint	255
APPENDICES		
Appendix A	Action Checklist for Candidates	257
Appendix B	The Functional Constituencies and their Electors	266

Appendix C	The Preferential Elimination System of Voting Applicable to the 4 Special Functional Constituencies: How Votes are Counted (with Annex showing Working Examples)	291
Appendix D	The Combined Polling Arrangements - Polling Stations for Various Kinds of Electors in the General Election	299
Appendix E	Methods of Folding of Election Advertisement	303
Appendix F	List of Posting Offices for Election Communication	305
Appendix G	Districts for Posting of Election Mail for Geographical Constituencies	310
Appendix H	Administrative Guidelines and Licensing Conditions for the issue of Public Fund-raising Permits for Non-Charitable Purposes – Application Form for a Permit	311
Appendix I	Fair and Equal Treatment of Candidates by the Print Media	320
Appendix J	Application Procedure for the Approval of Float Design	322
Appendix K	Canvassing Activities which are Forbidden Within a No Canvassing Zone	324
Appendix L	Items of Expenses which may be Counted towards Election Expenses	326
Appendix M	Support Clean Elections: A Handbook by the ICAC	329
Appendix N	Form of Consent of Support	360
Appendix O	Guidelines for Mutual Aid Committees	366
INDEX		369

CHAPTER 1

INTRODUCTION

PART I : THE LEGISLATIVE COUNCIL

1.1 The Legislative Council (“LegCo”) of the Hong Kong Special Administrative Region (“HKSAR”) is constituted under the Legislative Council Ordinance (Cap 542) (“LCO”) for the purpose of enacting laws, examining and approving budgets, taxation and public expenditure, receiving and debating the policy addresses of the Chief Executive (“CE”), raising questions on the work of the Government, debating issues concerning public interests and handling complaints from Hong Kong residents, etc.

1.2 In accordance with the Basic Law and the LCO, the term of office of the LegCo is 4 years except the first term which was 2 years. Each term of its office is to begin on a date to be specified by the CE in Council. The first term LegCo was between 24 May 1998 and 30 June 2000. The second term LegCo began on 1 October 2000 and is for 4 years (2000-2004). The CE must specify a date for holding a general election to elect the members for each term of office of the LegCo. A person returned as a member at a general election holds office from the beginning of the term of office of the LegCo next following the election and vacates office at the end of the term. A by-election will be held to fill a vacancy in membership of LegCo. However, no by-election is to be held within the 4 months preceding the end of the LegCo’s current term of office or if the CE has published in the Gazette an order dissolving that LegCo in accordance with the Basic Law.

1.3 The composition of the third term of the LegCo as set out in Annex II of the Basic Law is as follows:

- | | |
|--|----|
| (a) Members returned by geographical constituencies (“GCs”) through direct elections | 30 |
| (b) Members returned by functional constituencies (“FCs”) | 30 |

Geographical Constituency

1.4 The HKSAR is divided into 5 GCs, each having 4 to 8 seats. The GCs are geographically based and a total of 30 LegCo members will be returned through the following 5 GCs: Hong Kong Island to return 6 members; Kowloon East to return 5 members; Kowloon West to return 4 members; New Territories East to return 7 members; and New Territories West to return 8 members. The list system of proportional representation for voting is adopted. Details of the features of GC elections are set out in Chapter 2.

Functional Constituency

1.5 There is a total of 28 FCs, with each representing a different economic, social, or professional sector of the community. Thirty LegCo members will be returned through the following 28 FCs: (1) Heung Yee Kuk; (2) Agriculture and Fisheries; (3) Insurance; (4) Transport; (5) Education; (6) Legal; (7) Accountancy; (8) Medical; (9) Health Services; (10) Engineering; (11) Architectural, Surveying and Planning; (12) Labour; (13) Social Welfare; (14) Real Estate and Construction; (15) Tourism; (16) Commercial (first); (17) Commercial (second); (18) Industrial (first); (19) Industrial (second); (20) Finance; (21) Financial Services; (22) Sports, Performing Arts, Culture and

Publication; (23) Import and Export; (24) Textiles and Garment; (25) Wholesale and Retail; (26) Information Technology; (27) Catering; and (28) District Council. Of these 28 FCs, the Labour FC is to return 3 members and the remaining 27 FCs is each to return 1 member.

1.6 Different voting systems apply to elections of different FCs. They are:

- (a) the preferential elimination system of voting for the election for the 4 special FCs, ie Heung Yee Kuk FC, Agriculture and Fisheries FC, Insurance FC and Transport FC; and
- (b) the first past the post voting system for the election of the 24 ordinary FCs.

Details of the features of FC elections are set out in Chapter 3.

Governing Legislation

1.7 Two ordinances, ie the LCO and the Electoral Affairs Commission Ordinance (Cap 541) (“EACO”), govern the elections required for the establishment of the LegCo and direct how the elections should be conducted.

1.8 The LCO provides for the constitution and membership of LegCo, establishment of constituencies, registration of electors, conduct of elections, financial assistance for candidates, election petitions and other related matters.

1.9 The EACO tasks the Electoral Affairs Commission (“EAC”) with making recommendations regarding the delineation of GCs for the LegCo election and demarcation of their boundaries and regulating the printing of

particulars relating to candidates on ballot papers. The EAC is also responsible for the conduct and supervision of elections, and matters incidental thereto.

1.10 The electoral procedures for conducting the LegCo elections are provided in the Electoral Affairs Commission (Electoral Procedure) (Legislative Council) Regulation (“EAC (EP) (LC) Reg”). The Regulation will be amended by the EAC, as appropriate, taking into account representations made by the public on the EAC’s proposed guidelines during a consultation period before the commencement of an election.

1.11 The Electoral Affairs Commission (Registration of Electors) (Legislative Council Geographical Constituencies) (District Council Constituencies) Regulation (“EAC (ROE) (GC) Reg”) and the Electoral Affairs Commission (Registration) (Electors for Legislative Council Functional Constituencies) (Voters for Election Committee Subsectors) (Members of Election Committee) Regulation (“EAC (ROE) (FCSEC)”) set out the procedures for registration of electors for the LegCo elections.

1.12 The Particulars Relating to Candidates on Ballot Papers (Legislative Council) Regulation (“PCBP (LC) Reg”) sets out the procedures for printing specified particulars relating to candidates on ballot papers for use in the LegCo elections.

1.13 The Electoral Affairs Commission (Financial Assistance for Legislative Council Elections) (Application and Payment Procedure) Regulation (“EAC (FA) (APP) Reg”) stipulates the detailed implementation procedures for the Financial Assistance Scheme for candidates standing in LegCo elections.

1.14 Legislative Council (Subscribers and Election Deposit for Nomination) Regulation (“LC Subscribers & Deposit Reg”) sets out the requirements for subscription and payment and return of election deposit for the LegCo elections.

1.15 The Electoral Affairs Commission (Nominations Advisory Committees (Legislative Council)) Regulation (“EAC (NAC) (LC) Reg”) stipulates the appointment and functions of the Nominations Advisory Committees (“NACs”) and the procedures for seeking the NAC’s advice on the candidates’ eligibility for nomination for the LegCo elections.

PART II : THE GUIDELINES

1.16 According to s 6 of the EACO, the EAC may, in connection with an election, issue guidelines relating to:

- (a) the conduct or supervision of or procedure at an election;
- (b) election-related activities of a candidate, an agent of a candidate or any other person assisting a candidate, or any other person;
- (c) election expenses;
- (d) the display or use of election advertisements (“EAs”) or other publicity material; and
- (e) the procedure for making a complaint.

1.17 The aim of such guidelines is to provide a code of conduct based on the principle of fairness and equality for conducting election-related activities and some directions in layman's language on how to comply with the relevant electoral legislation so that candidates can avoid breaching them due to inadvertence. Guidelines are issued for reference by the public to ensure that all public elections are conducted in an open, honest and fair manner.

1.18 This set of Guidelines applies to both the LegCo general election and by-election. It explains the various electoral arrangements made for LegCo elections, the legislative provisions and regulations as well as guidelines that should be observed by all parties concerned before, during and after an election and the procedure for lodging an election-related complaint. An action checklist for candidates can be found in **Appendix A**.

1.19 In the context of this set of Guidelines, the term "election" means general election and by-election, as appropriate.

PART III : SANCTION

1.20 Members of the public, in particular, electors, candidates and their agents as well as government officials engaged in election-related duties should read, familiarise themselves with, and strictly observe, these Guidelines.

1.21 The EAC is committed to ensuring that all elections are conducted openly, honestly and fairly. If it comes to know that any candidate or person is in breach of the Guidelines, apart from notifying the relevant authorities for actions to be taken, it may make a reprimand or censure in a public statement which may include the name of the candidate or person concerned and other relevant parties, if any. The reprimand or censure is

separate from and additional to the criminal liability for any offences committed.

CHAPTER 2

GEOGRAPHICAL CONSTITUENCIES

PART I : DESCRIPTION

2.1 This chapter describes the GCs and the features relating to electoral procedure that electors of GCs may need to know. Electors of the FCs may refer to Chapter 3 : Functional Constituencies for details regarding the FCs.

2.2 In the general election for the third term of the LegCo, the 5 GCs are to return 30 of the 60 members of the LegCo, as follows:

- (a) the Hong Kong Island GC to return 6 members;
- (b) the Kowloon East GC to return 5 members;
- (c) the Kowloon West GC to return 4 members;
- (d) the New Territories East GC to return 7 members; and
- (e) the New Territories West GC to return 8 members.

PART II : REGISTRATION OF ELECTORS

Eligibility to Vote

2.3 Only a registered elector is eligible to vote at a LegCo election. A registered elector is a person whose name appears on the final register of GC which is in force at the time of election as compiled and published by the Electoral Registration Officer (“ERO”) under the LCO. An elector may vote at an election in respect of the GC within which his residential address as entered in the final register is located. [S 48 of the LCO.]

Qualifications for Registration as an Elector

2.4 To qualify for registration as an elector in a GC, an individual has to satisfy all the following requirements:

- (a) he has to be aged 18 years or above as at 25 July next following his application for registration;
- (b) he is a permanent resident of Hong Kong;
- (c) he ordinarily resides in Hong Kong and the residential address in his application for registration is his only or principal residence in Hong Kong;
- (d) he holds an identity document or has applied for a new identity document or a replacement identity document; and
- (e) he is not disqualified from being registered as an elector by virtue of s 31 of the LCO.

2.5 An individual who is **already registered** in the existing final register of GCs **need not apply** to be registered as an elector in a GC any further as his name and residential address will be repeated in the next register (a provisional register). However, he is not entitled to be an elector in the next register of GCs if he has ceased to ordinarily reside in Hong Kong, or no longer resides at the residential address recorded against his name in the existing register and the ERO does not know his new principal residential address in Hong Kong.

[Ss 24, 27, 28, 29 and 30 of the LCO.]

Disqualifications

2.6 A natural person is disqualified from being registered as an elector and voting at an election for a GC if he:

- (a) has ceased to be eligible to be a permanent resident of Hong Kong;
- (b) has, in Hong Kong or any other place, been sentenced to death or imprisonment (by whatever name called) and has not either served the sentence or any substitute sentence or received a free pardon;
- (c) on the polling day, is serving a sentence of imprisonment;
- (d) is or has been convicted of the following offences within 3 years before the polling day:

- (i) of having engaged in corrupt or illegal conduct in contravention of the Elections (Corrupt and Illegal Conduct) Ordinance (Cap 554) (“ECICO”), or
 - (ii) of an offence against Part II of the Prevention of Bribery Ordinance (Cap 201) (“POBO”), or
 - (iii) of any offence prescribed by regulations in force under the EACO, eg the provision of false information to the ERO;
- (e) is found for the time being under the Mental Health Ordinance (Cap 136) to be incapable, by reason of mental incapacity, of managing and administering his property and affairs; or
- (f) is a member of any armed forces.

[Ss 31 and 53 of the LCO.]

Roll-over of Electors

2.7 If an **individual** is **registered in the existing GC final register**, his name and residential address will be repeated in the next provisional register for GCs and he **does not need to make any application for registration**, unless he is not eligible to be an elector because:

- (a) he is dead;
- (b) he is not a permanent resident of Hong Kong;
- (c) he does not ordinarily reside in Hong Kong; or

- (d) he has changed his only or principal residence and his new address is not known to the ERO.

Application for Registration

2.8 The registration of GC electors is undertaken in accordance with the provisions of the EAC (ROE) (GC) Reg.

2.9 A person may send in his application for voter registration on the specified form to the ERO any time in the year. However, for inclusion of his name in the final register of GCs to be published not later than 25 July in a non District Council (“DC”) election year, his application form must have been received by the ERO **not later than 16 May** in that year. [S 4 of the EAC (ROE)(GC) Reg.]

2.10 The ERO will process the application forms after they have been received. An applicant who qualifies for registration will be allocated to the relevant GC on the basis of his residential address. Closer to the polling day, he will also be allocated to the appropriate polling station on the basis of his residential address and he will be notified in writing. The ERO will send written inquiries to applicants to seek information or proof if the information on their applications is incomplete or incorrect. Applicants who are not qualified for registration will also be informed of the result, by registered mail.

2.11 The name and residential address of all eligible applicants will be entered in the registers of electors.

Change of Residential Address

2.12 It will not be necessary for a registered elector to re-apply for registration every year unless he has changed his residential address. In such

a case, he **must notify** the ERO of his **new address** in Hong Kong to ensure that he will be registered in the current register of electors. **If he fails to do so, his name and address may be removed from the register**, and he will not be entitled to vote at subsequent elections.

2.13 If the elector has emigrated overseas and ceased to be a permanent resident of Hong Kong or ceased to ordinarily reside in Hong Kong, his name may also be removed from the register of electors.

Changes of Other Personal Particulars

2.14 Any registered elector who has changed his other particulars (eg name), or has ceased to be a permanent resident of Hong Kong or ceased to ordinarily reside in Hong Kong, should also notify the ERO.

2.15 An elector can notify the ERO of any change of any of his particulars in writing or by sending in a new registration form with the altered particulars. If the elector wishes to have the alteration of his particulars effected in the next final register of electors, he **must notify** the ERO as soon as possible and **latest by 29 June in a non DC election year**. An elector who has reported change of particulars will be sent a notice by the ERO showing his updated electoral record. [S 11(4) and (5) of the EAC (ROE) (GC) Reg.]

The Provisional Register

2.16 The provisional register for GCs will be published **not later than 15 June in a non DC election year**. It includes:

- (a) the names and addresses of those electors whose names appear in the existing final register for GC currently in force, updated and

corrected by the ERO based on reported or available information;
and

- (b) the names and addresses of the eligible new applicants who have applied for registration in the constituency concerned on or before 16 May of that year.

The provisional register will be **available for public inspection** at the Registration and Electoral Office (“REO”) and District Offices as specified in the Gazette notice of publication for a period after its publication and before the appeal deadline referred to in para. 2.18 below. [Ss 12 and 13 of the EAC (ROE) (GC) Reg.]

The Omissions List

2.17 At the same time when the provisional register for GCs is published, the ERO will also publish an omissions list, containing the names and residential addresses of persons who have been formerly registered as GC electors. These particulars are struck out from the provisional register and proposed to be omitted from the next final register, based on the information received by the ERO who is satisfied on reasonable grounds that these persons are no longer eligible to be registered or have been disqualified. [S 32(4)(a) and (b) of the LCO and ss 9 and 10 of the EAC (ROE) (GC) Reg.]

Appeals – Objections and Claims

2.18 Members of the public may lodge with the ERO objections as regards entries in the relevant provisional register **not later than 29 June in a non DC election year**. On or before that date, a dissatisfied applicant or a person whose name has been included in the omissions list may lodge a claim in respect of the entry or any omission concerning himself. Cases of

objections and claims will be referred to the Revising Officer for consideration. The Revising Officer, who is a member of the Judiciary, will rule on each objection or claim and decide on the inclusion, exclusion or correction of the entry concerned in the relevant final register. [S 34 of the LCO and Part III of the EAC (ROE) (GC) Reg.]

The Final Register

2.19 The final register for GCs will be published **not later than 25 July in a non DC election year**. It includes the entries in the relevant provisional register, the updated names and residential addresses of electors who have applied to alter their particulars not later than 29 June of that year, and the names and residential addresses of those who were subject to a notice of objection or claim, updated and corrected to reflect the decisions of the Revising Officer as appropriate. The ERO will have also taken the opportunity to delete those entries of electors who are known to be dead and to correct any mistakes in the provisional register. This final register remains valid until the publication of the final register in the following year. The final register in force will be available for public inspection at the REO and facilities will be available at District Offices for the public to search for information in the register. [S 20 of the EAC (ROE) (GC) Reg.]

IMPORTANT :

Information relating to a person contained in any register of electors or in any extract of any register of electors **can only be used for election-related purposes** under the electoral legislation. Any **abuse** or **misuse** of such information is an **offence** punishable with a fine at level 2 (up to \$5,000) and imprisonment for 6 months [s 22(3) of the EAC (ROE) (GC) Reg].

PART III : THE VOTING SYSTEM

2.20 Different voting systems apply to elections of GCs and different FCs. For GCs, the list system of proportional representation applies [s 49 of the LCO].

2.21 A poll will be taken in respect of a GC to return members for that constituency if the number of validly nominated candidates contesting the election is more than the number of members to be returned for the constituency. Where no more candidates have been validly nominated than the number of members to be returned for the constituency, the validly nominated candidates will be declared elected by the Returning Officer (“RO”). In such a case, polling in respect of the constituency will not be necessary and electors of the constituency concerned should not attend the relevant polling stations since they no longer need to vote. If no candidates were validly nominated or the number validly nominated was less than the number of members to be returned for the constituency, the RO must declare the election to have failed or, as the case may be, to have failed to the extent that the number of candidates validly nominated was less than the number of members to be returned [s 46(1) and (2) of the LCO.] A by-election will then be necessary.

2.22 In the list system of proportional representation, the nomination of candidates is to be by way of a list in a nomination form specified by the EAC to contain the names of one or more candidates for a GC as a group, and if more than one name, the names have to be ranked in the order of priority of the group. After the RO of the relevant GC has determined the eligibility of the candidates on a nomination list, only the eligible candidates whose priority on the list is above or equals the number of vacancies in the GC will be allowed to remain as candidates, and other candidates on the same list who rank after

those prior candidates will have their names excluded from the nomination list. If, after the close of nominations but before the date of the election, it comes to the knowledge of the RO that a candidate whose name appears on a list of candidates has died or is disqualified from being nominated as a candidate, the RO must strike out the name of that candidate from the list. After striking out a name from a list of candidates, the RO must not add the name of any other person to the list. If no name remains on the list of candidates, the RO must reject the list. [See s 38 of the LCO.]

2.23 At a GC election, an elector is entitled to cast a **single vote for a list** (as shown on the ballot paper) and not for an individual candidate. The number of valid votes cast for the election of the GC will be divided by the number of vacancies to be elected for that GC to arrive at the quota of votes. Each list that gets the quota will have one candidate on the list elected. When not all the vacancies are filled by applying the quota, then the filling of the remaining seat or seats will be decided by the largest remainder of valid votes cast for each list after the deduction of the quota or a number of quotas of votes cast for that list. If there are votes cast for a list that exceed the quota or quotas necessary to return all the candidates in the list, the list will be treated as having no further votes remaining. [See s 49 of the LCO.] For example, in a GC to elect 5 LegCo members, ie with 5 vacancies, where the number of valid votes cast is 1 million and there are 6 lists with varying number of candidates, the voting system operates in the following manner:

The quota of votes required to elect 1 candidate = $1,000,000 \div 5 = 200,000$

The valid votes cast for the 6 lists, eg:

<u>List 1</u>	<u>List 2</u>	<u>List 3</u>	<u>List 4</u>	<u>List 5</u>	<u>List 6</u>
Candidate A	Candidate F	Candidate J	Candidate M	Candidate O	Candidate Q
Candidate B	Candidate G	Candidate K	Candidate N	Candidate P	
Candidate C	Candidate H	Candidate L			
Candidate D	Candidate I				
Candidate E					
290,000	270,000	80,000	120,000	30,000	210,000
votes	votes	votes	votes	votes	votes

(votes cast for each of the Lists)

Step 1

No. of candidates in each List returned for satisfying the quota with the remainder votes:

<u>List 1</u>	<u>List 2</u>	<u>List 3</u>	<u>List 4</u>	<u>List 5</u>	<u>List 6</u>
Candidate A	Candidate F	None	None	None	Candidate Q
90,000	70,000	80,000	120,000	30,000	10,000
votes	votes	votes	votes	votes	votes
					(treated as no votes remaining)

(On applying the quota, 200,000 votes for List 1 enables Candidate A, being the first candidate in the priority ranking of List 1, to be elected. On the same basis, Candidate F on List 2 and Candidate Q on List 6 are elected. The remainder votes for List 1 and List 2 are then used to compare with the votes not meeting the quota cast for the other lists.)

Step 2

No. of candidates in each List returned by applying the remainder votes:

<u>List 1</u>	<u>List 2</u>	<u>List 3</u>	<u>List 4</u>	<u>List 5</u>	<u>List 6</u>
Candidate B	None	None	Candidate M	None	None

(Candidate M has the highest remainder of 120,000 votes, and candidate B has the next highest remainder of 90,000 votes. There are only 2 available vacancies after applying the quota in step 1, and they are filled by these 2 candidates whose lists have the highest 2 remainder votes in step 2. The rest of the candidates are not elected.)

2.24 If it is found that 2 or more lists have the equal largest number of remaining votes and the number of those lists exceeds the number of members remaining to be returned at that stage, the RO must determine the result by drawing lots. The member/members will be returned from the list/lists on which the lot falls [s 49(11) of the LCO].

2.25 When the drawing of lots has to be used to determine the result, 10 table-tennis balls each marked with a number from 1 to 10 will be put into an empty opaque bag, to be provided by the RO. The candidate or the representative of a candidate list is to draw 1 ball from the bag. The number marked on the ball should be noted by the RO and the ball should be put back into the bag. The other candidate(s) or representative(s) of candidate list(s) will draw in the same way. The candidate on whom the lot falls is to be returned at the election. The RO would draw the lot on behalf of the candidate or the representative of a candidate list if such candidate or representative is absent at the time of drawing lots.

- (a) Where there is only 1 vacancy to be filled and there are 2 candidates, the candidate who obtains the larger number from 1 to 10 will be the winner. 1 is the smallest number and 10 is the largest number.

- (b) Where there is only 1 vacancy to be filled and there are more than 2 candidates, if in the first draw, the numbers drawn are different, then the candidate who obtains the largest number will win. If, on the other hand, 2 or more of the candidates have obtained the same larger number and the remaining candidate(s) has/have obtained a smaller number, there must be a second draw. Only those candidates who have obtained the same larger number in the first draw will participate in the second draw.
- (c) Where there are 3 candidates having an equal number of votes and there are only 2 vacancies to be filled, if the 3 candidates have obtained respectively the largest, the larger and the smallest numbers, the 2 candidates who have obtained the largest and the larger numbers should be successful in getting the 2 vacancies, and the remaining candidate will fail. If the 3 candidates have obtained respectively 2 larger equal and 1 smaller numbers, then again the 2 candidates who have obtained the larger equal numbers will be the winners to fill the 2 vacancies. If the 3 candidates have obtained respectively a larger and 2 equal smaller numbers, the candidate who has obtained the larger number will be successful and the remaining 2 candidates will participate in a second draw. The same principle will apply where there are N candidates having an equal number of votes and there are less than N vacancies to be filled.

2.26 As soon as practicable after the result of the elections has been determined, the RO should publicly declare the successful candidates as elected.

2.27 If, after the counting of votes is finished but before the result of an election for a GC is declared, it comes to the knowledge of the RO that a

candidate on a list who was successful at the election has died or is disqualified from being elected, the RO must not declare that candidate as elected. If there is another candidate or there are other candidates on the same list who has not or have not been returned for the constituency, the candidate is to be returned or a candidate is to be returned according to the order of priority on the list in place of the deceased or disqualified candidate. If there is no other candidate on the same list who can be returned, the RO must publicly declare that the election has failed or has failed to the extent that the number of candidates returned at the election for the constituency was less than the number of members to be returned for the constituency. [See ss 46A(4), 49(14), (15) and (16) of the LCO and s 83(2)(a) and (b)(i) of the EAC (EP) (LC) Reg.]

CHAPTER 3

FUNCTIONAL CONSTITUENCIES

PART I : COMPOSITION

3.1 This chapter describes the FCs and the features relating to electoral procedure that electors of FCs may need to know. Electors of the GCs may refer to Chapter 2 : Geographical Constituencies.

3.2 In the general election for the third term of the LegCo, the 28 FCs are to return 30 of the 60 members of the LegCo.

3.3 The electorates of the 28 FCs are from particular professional, industrial or trade groups, etc. Except the Labour FC that is to return 3 members to LegCo, each of the other 27 FCs will return 1 member [see s 21 of the LCO]. The FCs and their electors are provided for in ss 20A to 20ZB of and Schedules 1 to 1E to the LCO, and are set out in **Appendix B**.

PART II : REGISTRATION OF ELECTORS

Eligibility to Vote

3.4 Only a registered elector, ie a person whose name appears on the final register of FC which is in force at the time of the election is eligible to vote. An elector may vote at an election in respect of an FC if he is registered as an elector in that constituency. [S 48 of the LCO.]

Qualification for Registration as an Elector

The 28 FCs [s 25 of the LCO]

3.5 Two kinds of persons (ie a natural person (individual) and a body) are eligible to be registered as FC electors. A person who is one specified in column 2 of Appendix B opposite an FC is eligible to be registered as an elector for that FC but if the person is an individual, he must **also** be either registered for a GC or eligible to be registered for a GC and has made an application to be so registered. (For registration as an elector for a GC, please refer to para. 2.4 of Chapter 2.)

3.6 If a person is **already registered** in the existing final register for one of the 28 FCs in Appendix B and is eligible to be, and not disqualified from, being registered as an elector for the FC, then his/its name and address will be repeated in the next provisional register for FCs, and he/it **need not apply** to be registered.

3.7 A body specified in item 3, 12, 20, 21(1), 22(2), (4), (5), (10) or (11), 23(1) to (4), 24(4) or (5), 26(14) or 27(1) of Appendix B is eligible to be registered as a corporate elector for the relevant FC only if it has been operating for the 12 months immediately before making its application for registration as an elector.

3.8 A body that is a corporate member of a representative organisation specified in item 2(1), 14 to 19, 21(2), 22(1) or (7) to (9), 23(5), 24(1) or (2), 25 or 26(10), 12(a) or (13) of Appendix B is eligible to be registered as a corporate elector for the relevant FC if it has been a corporate member of the representative organisation and has been operating for the 12 months immediately before making its application for registration as an elector.

3.9 An individual who is a member of a representative organisation specified in item 14, 17, 18, 21(2), 22(7) to (9), 23(5), 24(3) or 25 of Appendix B is eligible to be registered as an elector for the relevant FC only if the person has been a member of the body for the 12 months immediately before making an application for registration as an elector.

3.10 No person may be registered in 2 or more FCs. If he/it is eligible to be registered in 2 or more FCs, except any one of the 4 FCs shown in the following paragraph, he/it may choose to be registered in any one of the FCs.

3.11 A person who is eligible to be registered in one of the following 4 FCs, and if he wants to be registered as an FC elector, has **no choice** but to be registered in that FC although he may be eligible for any other FC. The voting system for these 4 FCs is different from that for the other 24 FCs (see paras. 3.28-3.30 below):

- (a) Heung Yee Kuk FC,
- (b) Agriculture and Fisheries FC;
- (c) Insurance FC; and
- (d) Transport FC.

These 4 special FCs (FCs specified in s 20(1)(a) to (d) of the LCO) (items 1 - 4 of Appendix B) are referred to as “SFCs” below.

Authorised Representative [s 26 of the LCO]

3.12 A corporate elector is required to select an eligible individual to

be its authorised representative (“AR”) for the purpose of casting its vote at any election, otherwise it cannot vote [see also s 48(8) of the LCO]. An individual is eligible to be appointed as an AR of a corporate elector only if he:

- (a) is registered, or eligible to be and has applied to be registered, as an elector of a GC;
- (b) is a member, partner, officer or employee of the corporate elector or has a substantial connection with it;
- (c) is not registered, and has not applied to be registered, as an elector for the FC of the corporate elector; and
- (d) is not disqualified from being registered or voting under s 31 or 53 of the LCO (see para. 3.15 below).

3.13 An AR of a corporate elector is not eligible to be selected as the AR of another corporate elector.

3.14 An AR must be registered with the ERO. **A corporate elector is required to give notice of appointment of its AR to the ERO in its application form for registration as a corporate elector.** It may thereafter from time to time appoint a replacement AR by sending a specified form to reach the ERO not later than 14 days before the polling day of its FC. If the ERO is satisfied that the AR is dead or seriously ill or physically or mentally incapacitated, the deadline of 14 days for replacement is extended to 3 working days before the relevant polling day. [See s 20 of the EAC (ROE) (FCSEC) Reg.]

Disqualifications

3.15 A natural person is disqualified from being registered as an elector and voting at an election for an FC or as an AR if he :

- (a) has ceased to be eligible to be registered as an elector for the GC;
- (b) has ceased to remain qualified for the FC (this does not apply to an AR or an elector for a GC);
- (c) has, in Hong Kong or any other place, been sentenced to death or imprisonment (by whatever name called) and has not either served the sentence or any substitute sentence or received a free pardon;
- (d) on the polling day, is serving a sentence of imprisonment;
- (e) is or has been convicted of the following offences within 3 years before the polling day:
 - (i) of having engaged in corrupt or illegal conduct in contravention of the ECICO, or
 - (ii) of an offence against Part II of the POBO, or
 - (iii) of any offence prescribed by regulations in force under the EACO, eg the provision of false information to the ERO;
- (f) is found for the time being under the Mental Health Ordinance (Cap 136) to be incapable, by reason of mental incapacity, of managing and administering his property and affairs; or

(g) is a member of any armed forces.

[Ss 31 and 53 of the LCO.]

Roll-over of Electors

3.16 If an individual has been an elector in the FC final register, his name and residential address will be repeated in the next provisional register for FCs and he does not need to make any application for registration, unless he is no longer eligible to be a GC elector or has ceased to be eligible to be an elector of the relevant FC. The same rules apply to a corporate body whose name and particulars have appeared in the existing final register of the relevant FCs.

Application for Registration

3.17 The registration of electors is undertaken in accordance with the provisions of the EAC (ROE) (FCSEC) Reg.

3.18 A person (either an individual or a body) may send in his application for voter registration on the specified form to the ERO any time in the year. However, for inclusion of his name in the final register to be published on or before 25 July in a non DC election year, his application form must be received by the ERO **on or before 16 May of that year.**

3.19 The ERO will process the application forms after they have been received. An applicant who qualifies for registration will be allocated to the relevant FC, as appropriate, in accordance with his qualification and choice (if so entitled). Closer to the polling day, he will also be allocated to the appropriate polling station on the basis of his residential address and the respective constituencies in which he is registered, and he will be notified in

writing. The ERO will send written inquiries to applicants to seek further information or proof if the information on their applications is incomplete or incorrect. Applicants who are not qualified for registration will also be informed by registered mail.

3.20 The name and residential address of all eligible applicants will be entered in the registers of electors, including the name and business address of the relevant body, and the name of the AR of the body.

Change of Residential Address

3.21 It will not be necessary for a registered elector to re-apply for registration every year unless he has changed his residential address. In such a case, he **must notify** the ERO **of his new address** in Hong Kong to ensure that he will be registered in the current register of electors. **If he fails to do so, his name and particulars may be removed from the register.** A registered elector should also notify the ERO of any change of his circumstances that may affect his eligibility (eg his connection with a particular FC). Based on such information from the elector, the ERO will decide whether he remains eligible to be registered, and if so, in which constituency.

3.22 If the elector has emigrated overseas and ceased to be a permanent resident of Hong Kong or ceased to ordinarily reside in Hong Kong, his name may also be removed from the register of electors.

Changes of Other Personal Particulars

3.23 Any registered elector who has changed his other personal particulars (eg name), or has ceased to be a permanent resident of Hong Kong or ceased to ordinarily reside in Hong Kong, should also notify the ERO. An elector should notify the ERO of any change of any of his particulars in writing

or by sending in a new registration form with the altered particulars. If the elector wishes to have the alteration of his particulars effected in the next final register of electors, he **must notify** the ERO as soon as possible and the **latest by 29 June in a non DC election year**. An elector who has reported change of particulars will be sent a notice by the ERO showing his updated electoral record. [S 26 of the EAC (ROE) (FCSEC) Reg.]

The Provisional Registers

3.24 The provisional register for FCs will be published **not later than 15 June in a non DC election year**. It includes:

- (a) the names and addresses of those electors whose names appear in the relevant register currently in force, updated and corrected by the ERO based on reported or available information;
- (b) the names and addresses of the eligible new applicants who have applied for registration in the constituency concerned on or before 16 May of that year; and
- (c) the names of the ARs of the corporate electors.

The provisional registers will be **available for public inspection** at the REO and certain District Offices, as specified in the Gazette notice of publication for a period after its publication and on or before the appeal deadline referred to in para. 3.27 below. [Ss 27 and 29 of the EAC (ROE) (FCSEC) Reg.]

The Omissions List

3.25 By the time when the provisional registers are published, the ERO will also publish an omissions list each in respect of FCs containing the

names and addresses of persons who were formerly registered as FC electors, but are struck out from the provisional register and proposed to be omitted from the next final register, based on the information received by the ERO who is satisfied on reasonable grounds that the concerned persons are no longer eligible to be registered or are disqualified. The names and addresses of the persons included in the omissions list will not appear on the provisional register. [S 32(4)(a) and (b) of the LCO and ss 24 and 25 of the EAC (ROE) (FCSEC) Reg.]

Appeals – Objections and Claims

3.26 Members of the public may lodge with the ERO objections as regards entries in the relevant provisional register **not later than 29 June in a non DC election year**. On or before that date, a dissatisfied applicant or a person whose name has been included in the omissions list may lodge a claim in respect of the entry or any omission concerning himself/itself. Cases of objections and claims will be referred to the Revising Officer for consideration. The Revising Officer, who is a member of the Judiciary, will rule on each objection or claim and decide on the inclusion, exclusion or correction of the entry concerned in the relevant final register. [S 34 of the LCO and Part VI of the EAC (ROE) (FCSEC) Reg.]

The Final Registers

3.27 The final register for FCs will be published **on or before 25 July in a non DC election year**. It includes the entries in the relevant provisional register, the updated names and addresses of electors who have applied to alter their particulars on or before 29 June of that year, and the names and addresses of those who were subject to a notice of objection or claim, updated and corrected to reflect the decisions of the Revising Officer as appropriate. The ERO will have also taken the opportunity to delete those entries of electors

who are known to be dead and to correct any mistakes in the relevant provisional register. The final registers may also contain notations to show if a person registered for a GC is also registered in an FC. The final registers for FCs remain valid until the publication of the relevant final register in the following year. The final registers in force will be available for public inspection at the REO and facilities will be available at District Offices for the public to search for information in the register. [S 38 of the EAC (ROE) (FCSEC) Reg.]

IMPORTANT :

Information relating to a person contained in any register of electors or in any extract of any register of electors **can only be used for election-related purposes** under the electoral legislation. Any **abuse** or **misuse** of such information is an **offence** punishable with a fine at level 2 (up to \$5,000) and imprisonment for 6 months [s 42(3) of the EAC (ROE) (FCSEC) Reg].

PART III : THE VOTING SYSTEMS

3.28 Different voting systems apply to elections of different constituencies, namely,

- (a) for the 4 SFCs referred to in para. 3.11 above (items 1 – 4 of Appendix B), the preferential elimination system of voting; and
- (b) for the 24 ordinary FCs, the first past the post voting system.

The Preferential Elimination System for the 4 SFCs

3.29 For each of the 4 SFCs, an elector is entitled to cast a single vote. The vote is transferable amongst the candidates nominated for the election, with the elector marking his preference or preferences for those candidates on the ballot paper against one or more of those candidates in descending order. In order to be elected, a candidate must obtain an absolute majority of the valid votes. If no candidate obtains an absolute majority of the votes at a particular stage of the counting of votes, the candidate with the least number of votes is to be eliminated at that stage, and that candidate's votes are to be transferred to the candidates then remaining in accordance with the next available preferences marked on the ballot papers. This process is to continue until one candidate obtains an absolute majority over the other candidate or candidates then remaining. [S 50 of the LCO.] If, after the counting of votes is finished but before the result of an election of an FC is declared, it comes to the knowledge of the RO that the candidate who was successful at the election has died or is disqualified from being elected, that RO must not declare that candidate as elected and must publicly declare that the election has failed [ss 46A(3) and 50(8) of the LCO]. Details of how the votes are to be counted are set out in **Appendix C**.

The First Past the Post Voting System for the 24 Ordinary FCs

3.30 An elector of each of the 24 ordinary FCs is entitled to vote for as many candidates as there are vacancies and no more. The candidate who obtains the greatest number of votes will be elected, followed by the next candidate who has the next greatest number of votes, and so on, until all the vacancies are filled. [S 51 of the LCO.] Out of the 24 ordinary FCs, only the Labour FC has 3 seats to be filled and electors of that ordinary FC can therefore vote for up to 3 candidates. In each of the remaining 23 ordinary FCs, only 1 seat is to be filled and the elector can only vote for 1 candidate.

In the event that more than 1 candidate has the equal highest number of votes, the RO will have to draw lots to determine which one of these candidates should be elected to fill the vacancy.

3.31 When the successful candidate has to be determined by the drawing of lots, 10 table-tennis balls each marked with a number from 1 to 10 will be put into an empty opaque bag, to be provided by the REO. Each candidate is to draw 1 ball from the bag. The number marked on the ball should be noted by the RO and the ball should be put back into the bag. The other candidate(s) will draw in the same way. The candidate on whom the lot falls is to be returned at the election. The RO would draw the lot on behalf of the candidate if the latter is absent at the time of drawing lots.

- (a) Where there is only 1 vacancy to be filled and there are 2 candidates, the candidate who draws the larger number from 1 to 10 will be the winner. 1 is the smallest number and 10 is the largest number.
- (b) Where there is only 1 vacancy to be filled and there are more than 2 candidates, if in the first draw, the numbers drawn by the candidates are different, then the candidate who draws the largest number will win. If, on the other hand, 2 or more of the candidates have drawn the same larger number and the remaining candidate(s) has/have drawn a smaller number, there must be a second draw. As the system of voting for the election is “first past the post”, only those candidates who have drawn the same larger number in the first draw will participate in the second draw.
- (c) Where there are 3 candidates having an equal number of votes and there are only 2 vacancies to be filled, if the 3 candidates have obtained respectively the largest, the larger and the smallest

numbers, the 2 candidates who have obtained the largest and the larger numbers should be successful in getting the 2 vacancies, and the remaining candidate will fail. If the 3 candidates have obtained respectively 2 larger equal and 1 smaller numbers, then again the 2 candidates who have obtained the larger equal numbers will be the winners to fill the 2 vacancies. If the 3 candidates have obtained respectively a larger and 2 equal smaller numbers, the candidate who has obtained the larger number will be successful and the remaining 2 candidates will participate in a second draw. The same principle will apply where there are more than 3 candidates having an equal number of votes and there are 3 vacancies to be filled as in the case of the Labour FC.

3.32 As soon as practicable after the result of the elections has been determined, the RO should publicly declare the successful candidate as elected.

3.33 In the event that before the declaration of the result of the elections, proof is given to the RO's satisfaction that the successful candidate for a constituency has passed away or has been disqualified from being elected, the RO should not declare that candidate as elected and should declare that the election has failed or has failed to the extent that the number of candidates returned at the election was less than the number of members to be returned. [See ss 46A and 51(8) of the LCO.]

CHAPTER 4

NOMINATION OF CANDIDATES

PART I : QUALIFICATION AND DISQUALIFICATION FOR NOMINATION

4.1 The law governing the qualification and disqualification for the nomination of candidates for the LegCo election is contained in the LCO. The procedure for nomination of candidates for the LegCo election is provided in the EAC (EP) (LC) Reg made by the EAC.

Qualifications

4.2 To qualify for nomination as a candidate at an election for a GC, a person must:

- (a) be 21 years of age or over;
- (b) be both registered and eligible to be registered as an elector for a GC;
- (c) not be disqualified from being elected by virtue of s 39 of the LCO (see para. 4.5 below);
- (d) have ordinarily resided in Hong Kong for the 3 years immediately preceding the date of his nomination; and

- (e) be a Chinese citizen who is a permanent resident of Hong Kong with no right of abode in any country other than the People's Republic of China.

[S 37 of the LCO.]

4.3 To qualify to be nominated as a candidate at an election for an FC, a person must:

- (a) satisfy para. 4.2(a) to (e) above, save that for the following 12 FCs, para. 4.2(e) does not apply, namely,
 - (i) Legal FC,
 - (ii) Accountancy FC,
 - (iii) Engineering FC,
 - (iv) Architectural, Surveying and Planning FC,
 - (v) Real Estate and Construction FC,
 - (vi) Tourism FC,
 - (vii) Commercial (first) FC,
 - (viii) Industrial (first) FC,
 - (ix) Finance FC,
 - (x) Financial Services FC,
 - (xi) Import and Export FC, and
 - (xii) Insurance FC; and
- (b) be both registered and eligible to be registered as an elector for the relevant FC or satisfy the RO for the constituency that he has a substantial connection with that FC.

4.4 A person is considered to have **ordinarily resided in Hong Kong** when he has habitually and normally lived there lawfully for a settled

purpose, apart from temporary and occasional absences such as holidays and absence abroad for studying purposes. Each case has to be examined upon its own facts. Matters like the length of the person's absence, the reason for his absence, the location of the home of him, his spouse, children and parents and his maintenance of connections with Hong Kong are all relevant factors. In case of doubt, a prospective candidate should consult his own legal adviser or seek advice from the NAC [see paras. 4.7 - 4.13 below].

Disqualifications

4.5 A person will be disqualified from being nominated, if he:

- (a) is a judicial officer, or a prescribed public officer¹;
- (b) is an officer of the LegCo or a member of staff of The LegCo Commission;
- (c) has, in Hong Kong, or any other places, been sentenced to death or imprisonment (by whatever name called), and has not either served the sentence or any substitute sentence or received a free pardon;
- (d) has been convicted of treason;

¹ A prescribed public officer means any of the following:

- (a) the Chairman of the Public Service Commission;
- (b) the Commissioner and Deputy Commissioner of the Independent Commission Against Corruption ("ICAC") and the holder of any other office under the ICAC Ordinance (Cap 204);
- (c) the Ombudsman and the holder of any appointment under s 6 of The Ombudsman Ordinance (Cap 397);
- (d) a member of the EAC;
- (e) the chief executive of the Monetary Authority and any member of the senior management of that Authority, including divisional heads, executive directors, managers and counsel employed by that Authority;
- (f) the Privacy Commissioner for Personal Data and any person employed or engaged by him under the Personal Data (Privacy) Ordinance (Cap 486);
- (g) the Chairperson of the Equal Opportunities Commission and any person employed or whose services are engaged by the Commission under the Sex Discrimination Ordinance (Cap 480); or
- (h) any person holding an office, whether permanent or temporary, in a government department or bureau and employed in the department or bureau.

- (e) on the date of nomination, or of the election, is serving a sentence of imprisonment;
- (f) is or has been convicted, within 5 years before the polling day, of any offence in Hong Kong or in any other place, the sentence for which is imprisonment (suspended or not) for not less than 3 months, or convicted of having engaged in corrupt or illegal conduct in contravention of the ECICO, or convicted of any offence against Part II of the POBO or any offence prescribed by the regulations made by the EAC;
- (g) is ineligible because of operation of the LCO or any other law;
- (h) is a representative or a salaried functionary of the government of a place outside Hong Kong;
- (i) is a member of any national, regional or municipal legislature, assembly or council of any place outside Hong Kong, other than a people's congress or people's consultative body of the People's Republic of China, whether established at the national level or local level;
- (j) is an undischarged bankrupt; or
- (k) is found for the time being under the Mental Health Ordinance (Cap 136) to be incapable, because of mental incapacity, of managing and administering his property and affairs.

[S 39(1) and (2) of the LCO.]

4.6 A person is also disqualified from being treated as a member for an FC if, since the close of nominations, the person has ceased to have a substantial connection with the constituency [s 39(4) of the LCO].

PART II : NOMINATIONS ADVISORY COMMITTEES

4.7 The EAC has the power to appoint NACs to provide advice, on request, to prospective candidates and ROs on the candidates' eligibility for nomination. [S 3 of the EAC (NAC) (LC) Reg.] Each of these NACs is in the charge of either a Senior Counsel or a legal practitioner of not less than 10 years standing who, in the opinion of the EAC, is unconnected to any candidate or political organisation in Hong Kong, independent and impartial.

NAC's Service to Candidates

4.8 NAC's service will be provided to candidates only at a LegCo general election. During a period to be announced by the REO – which normally ends one day before the commencement of the nomination – a prospective candidate may apply, by completing a specified application form obtainable from the REO or from any District Office, for the advice of the NAC as to whether he is qualified to be, or is disqualified from being, nominated as a candidate at the LegCo general election. He may make only one application in respect of the GC election and one application in respect of a particular FC election. While a prospective candidate may apply for advice only once in respect of a particular FC, he may apply for advice in respect of more than one FC.

4.9 The application should be:

- (a) sent to the Chief Electoral Officer (“CEO”) so as to be received by him:
 - (i) by post; or
 - (ii) by facsimile transmission; or
- (b) served on the CEO personally,

on or before the deadline for application to be specified by the EAC.

4.10 An NAC may, before giving its advice, request the applicant to make available to it within a specified period any information, particulars and evidence relating to his intended candidature. The NAC may also request the applicant to present himself before it at a specified time and place to assist it in the consideration of the application. The applicant may, at the specified time and place, make representations to the NAC personally or through any person authorised by him in writing for the purpose.

4.11 Where an applicant does not make available any information, particulars or evidence as requested by the NAC, or fails to present himself before the NAC in response to a request, the NAC may:

- (a) refuse to consider the application or to give any advice on it; or
- (b) give qualified advice on the application having regard to either or both of the following:
 - (i) the fact that any information, particulars or evidence, or where appropriate, all of them, were not available to it;

- (ii) the failure of the applicant to present himself before the NAC.

4.12 The NAC's advice to an applicant, including a decision to refuse to consider an application or to give advice, will be in writing and will be sent to the applicant not later than a date to be specified by the EAC.

4.13 Any advice given by an NAC or a refusal to give any such advice does not preclude a person from seeking nomination as a candidate in an election or proceeding with a nomination, if he so wishes.

[S 5 of the EAC (NAC) (LC) Reg.]

NAC's Service to ROs

4.14 NAC's service will be provided to ROs at both LegCo general elections and by-elections. During the period from the commencement, up to one day after the close of the nomination period, ROs may seek the advice of an NAC, where they consider necessary, on the eligibility for nomination of the candidates who have submitted their nominations. Such application must be in writing and made to the NAC through the CEO. The NAC will, not later than a date specified by the EAC, advise the RO concerned as to whether the candidate concerned is eligible to be nominated.

4.15 An RO is required, in making a decision as to whether a particular candidate is validly nominated in respect of the constituency for which he seeks nomination, to have regard to any advice given by an NAC on that candidate [s 17 of the EAC (EP) (LC) Reg]. The decision on the validity of nomination, however, remains with the RO alone.

[S 6 of the EAC (NAC) (LC) Reg.]

PART III : WHEN AND HOW TO NOMINATE

When to Nominate

4.16 Nomination may be made during the **nomination period** specified in the Notice of Election published in the Gazette [ss 4, 5 and 7 of the EAC (EP) (LC) Reg]. An election timetable will be provided to each candidate by the RO for the relevant constituency. The ordinary business hours on each working day (ie any day other than a general holiday or Saturday) in the nomination period for the ROs to accept nominations are from 9 am to 5 pm, and on a Saturday, from 9 am to 12 noon. **Candidates are encouraged to submit their nominations well before the expiration of the nomination period to allow time for any errors in their nomination forms to be corrected.**

How to Nominate

4.17 Nomination forms specified by the EAC are available from any District Office or from the REO, or can be downloaded from the website of the REO (<http://www.info.gov.hk/reo>).

4.18 The nomination form comprises:

(a) **The Nomination**

- (i) In respect of a **GC** election, the nomination is a list containing either the names of 2 or more proposed candidates contesting the election of the particular GC as a group with their names ranked in the order of priority of the group, or the name of a single proposed candidate.

The nomination must be subscribed by **100 registered electors** (other than the candidates) of that particular GC assenting to the nomination and the number of persons that may subscribe a nomination shall not be more than 200 [s 7(1)(a) and (aa) of the LC Subscribers & Deposit Reg]. An elector may subscribe only one nomination as regards a particular GC election. Under s 38 of the LCO, after a nomination has been submitted to an RO, the order in which the names of proposed candidates appear in the list cannot be altered, no other name of any proposed candidate can be added to the list, and names already on the list cannot be deleted. (See, however, para. 4.36 below in the case of withdrawal.)

- (ii) In respect of a candidate of an **FC**, it must be subscribed by **10 registered electors** (other than the candidate himself) and the number of persons that may subscribe a nomination shall not be more than 20 [s 7(2)(a) and (aa) of the LC Subscribers & Deposit Reg]. An elector may subscribe any number of nomination papers up to the number of seats in any FC [s 7(2)(b) of the LC Subscribers & Deposit Reg]. Thus, an elector of the Labour FC may subscribe up to 3 nominations as there are 3 vacancies to fill in that FC. For other FCs, with one seat each, an elector may only subscribe 1 nomination.

In any of the above cases, **the subscribing elector must be registered for the GC or the FC concerned**, as the case may be. In other words, **an elector** in respect of a GC and an FC is entitled to **subscribe only one nomination regarding his own GC and any number of nomination up to the number of vacancies regarding his FC**. Where the number of persons subscribing a

nomination has exceeded the required number (ie 100 for a GC election and 10 for an FC election), any surplus over the required number of qualified subscribers will be regarded as not having subscribed the nomination concerned [s 7(2C) of the LC Subscribers & Deposit Reg]. In this case, the elector may subscribe another nomination instead. If the nomination subscribed by an elector has been held to be invalid, or the candidate or all the nominees on a nomination list has withdrawn his/their nomination, the elector may subscribe another one instead before the end of the relevant nomination period, and his signature shall not be inoperative on that other nomination form. If he subscribes more than one nomination form in contravention of the regulations, his signature shall be operative only on the first one delivered [s 7(3)(ii) of the LC Subscribers & Deposit Reg].

IMPORTANT :

A candidate who submits a nomination form on the last few days of the nomination period is advised to include more than the required number of subscribers for his nomination, to avoid the risk of invalidation of the nomination should one or more of the subscribers be subsequently found not to be qualified as subscribers. A candidate should use his best endeavour to ensure that the electors subscribing his nomination form are eligible and have not subscribed another nomination previously. Electors subscribing a nomination should sign the nomination form **personally**.

(b) **The Candidate's Consent to Nomination and Declarations**

This must be completed and signed by the candidate and endorsed by a witness. There are the following **declarations** and promissory oath that a candidate must make and sign:

- (i) a declaration to the effect that the candidate will uphold the Basic Law and pledge allegiance to the Hong Kong Special Administrative Region;
- (ii) a declaration as to the candidate's nationality and as to whether or not he has a right of abode in a country other than the People's Republic of China;
- (iii) a promissory oath given by the candidate to the effect that, if elected, he will not do anything during his term of office that results in his disqualification, including mainly those set out in para. 4.5 above, plus becoming a member of any armed forces;
- (iv) a declaration to the effect that the candidate (in the case of a GC list, each candidate) is eligible to be nominated as a candidate for the constituency concerned; is not disqualified from being so nominated; and consents to being so nominated. In the case of a GC list, each candidate must also declare his consent to the order of priority in which the names of candidates appear on the nomination list; and
- (v) a declaration to the effect that the candidate (in the case of a GC list, each candidate) has ordinarily resided in Hong Kong for the 3 years immediately preceding the date of his nomination.

[S 40 of the LCO and ss 10 and 11 of the EAC (EP) (LC) Reg.]

IMPORTANT :

No person shall be nominated in an election as a candidate for more than one constituency [s 41 of the LCO]. When a person

submits his nomination form, he must have withdrawn all his prior nominations, if any, and make a declaration (contained in the specified form) that either he has not been nominated before for any other constituency in the election, or if he has been so, he has withdrawn all those prior nominations. Where a candidate stands nominated [see para. 4.25 below], any subsequent nominations of his will be rejected as invalid.

In the nomination form, a candidate is required to state his occupation, and he is free to state his political affiliation for publication if he so prefers. Candidates should make sure that their nomination forms are properly completed before submission.

4.19 Each nomination form must be submitted to the RO for the constituency concerned together with the payment of an appropriate election deposit (see Part IV of this chapter for details). The RO may refuse to accept any nomination form where there is a material alteration of its content.

4.20 The completed nomination form must be lodged with the RO for the constituency concerned by the candidate, and in case of a list of candidates by one of the candidates, **in person** during ordinary business hours, ie the hours between 9 am and 12 noon on a Saturday and the hours between 9 am and 5 pm on any day other than a general holiday, within the nomination period. In the case of nominations for FC elections, the CEO may, in exceptional circumstances, eg the nominee's temporary absence from Hong Kong or incapacity due to illness, authorise other form of delivery of the nomination form to the RO [s 11(14) of the EAC (EP) (LC) Reg].

False Declarations

4.21 A candidate who knowingly and wilfully makes a statement which is false in a material particular in the declaration in the nomination form shall be guilty of an offence under the Crimes Ordinance (Cap 200) punishable by a fine and imprisonment of up to 2 years.

PART IV : ELECTION DEPOSIT

Payment of Election Deposit

4.22 Each nomination form must be presented with the payment of an election deposit, in cash, cashier order or by cheque, in such amount as prescribed by regulation made by the CE in Council [ss 40(3) and 82(2)(b) of the LCO]. The following election deposits are prescribed by s 2 of the LC Subscribers & Deposit Reg:

for all the candidates on a GC list	\$50,000
for a candidate of an FC	\$25,000

4.23 A nomination form will not be received by the RO unless it is accompanied by the required sum of election deposit.

IMPORTANT :

Candidates are encouraged to pay their election deposit by cash or cashier order although they may pay by crossed cheque. In the event that a cheque is dishonoured, the nomination will be ruled invalid unless the sum of deposit is made good before the

expiration of the nomination period. In order to avoid the risk of invalidation of the nomination due to dishonoured cheque, candidates are strongly advised to submit the election deposit in cash or cashier order if they submit nomination in the last 3 working days (excluding Saturday) of the nomination period.

Return of Election Deposit

4.24 The deposit will be returned to the candidate (or in the case of a list of candidates, the person who lodged the deposit on behalf of the list) if:

- (a) he is not validly nominated (and in the case of a list of candidates, if all the candidates on the list are not validly nominated);
- (b) his nomination is withdrawn (and in the case of a list of candidates, if all the candidates on the list have withdrawn their nomination);
- (c) he has died or is disqualified from being nominated (and in the case of a list of candidates, if all the candidates on the list have died or are disqualified from being nominated);
- (d) in the case of a list of candidates, the list is rejected by the RO after he has struck out from the list all the names of candidates for any one, or any combination, of the reasons stated in items (a), (b) or (c) above;
- (e) the election is terminated;
- (f) he is elected (and in the case of a list of candidates, if the first ranked candidate on the list is elected);

- (g) in the case of a GC or one of the ordinary FCs, other than the 4 SFCs, he or the list of candidates secures in his or its favour not less than 3% of the total number of ballot papers containing valid votes received in that constituency; or
- (h) in the case of one of the 4 SFCs, he secures in his favour not less than 3% of the total number of ballot papers containing valid first preference votes received in that constituency;

The deposit will be forfeited if none of the above conditions is satisfied. [For details, see ss 3 and 4 of the LC Subscribers & Deposit Reg.]

PART V : VALIDITY OF NOMINATIONS

[Ss 16, 17 and 18 of the EAC (EP) (LC) Reg]

4.25 Where the RO has received a nomination form within the nomination period, the candidate will be deemed to stand nominated unless the RO decides that the nomination is invalid.

4.26 The RO will make a decision as to the validity of a nomination as soon as practicable after receipt of the nomination form and will publish a notice stating which persons are validly nominated as candidates [s 42A(1) and (2) of the LCO].

4.27 Where an RO has doubts as to whether or not a particular candidate is qualified to be nominated, he may apply to an NAC for advice (see para. 4.14 above).

4.28 Where a nomination appears to the RO to be invalid because of some errors which can be corrected within the nomination period, the RO will, if practicable, give the candidate a reasonable opportunity of correcting the errors before making a decision that the nomination is invalid. For example, if the entitlement of any subscriber is in doubt, a prospective candidate may be allowed to make a substitution as soon after the submission of his nomination form as practicable. However, no substitution for any subscriber or re-submission of a nomination form will be accepted after the close of the nomination period.

4.29 A nomination may be ruled invalid if any errors on the nomination form are not corrected by the close of the nomination period.

4.30 The RO may require such additional information from a candidate as he considers necessary to satisfy himself as to the validity of the nomination.

4.31 A nomination will not be valid unless it contains all the information and signatures required to be shown on the nomination form or by the RO and the candidate has made the declarations and oath referred to in para. 4.18(b) above.

4.32 The RO can decide that a nomination is invalid only where:

- (a) the number or qualifications of the subscribers are not as required by LC Subscribers & Deposit Reg;
- (b) the nomination form, including the nomination and declarations and oath, has not been completed or signed as required by s 40 of the LCO and ss 10 and 11 of the EAC (EP) (LC) Reg;

- (c) he is satisfied that the candidate or all the candidates on the GC list is/are not qualified to be, or is disqualified from being, nominated as a candidate, having regard to any advice given by the NAC to an application made by him or by that candidate [see paras. 4.15 and 4.27 above];
- (d) the candidate or all the candidates on the GC list has/have been nominated for another constituency in the same election and the RO is not satisfied that he has withdrawn that candidature;
- (e) the cheque for the payment of the election deposit of the candidate is dishonoured and has not been made good before the expiration of the nomination period;
- (f) he is satisfied that the candidate has passed away; or
- (g) the nomination form is not duly lodged within the nomination period [see paras. 4.16 and 4.20 above].

4.33 If, having decided that a candidate is validly nominated for election for a GC but before the polling day, proof is given to the satisfaction of the RO that the candidate has died, he must publicly declare that the candidate has died and further declare which candidate is or candidates are validly nominated for that constituency. The RO does not have to make any such declaration if the candidate who has died is uncontested in the election in his constituency and the RO has publicly declared that the candidate was duly elected [s 42B(1), (2) and (3) of the LCO].

4.34 If, having decided that a candidate is validly nominated for election for a GC but before the polling day, proof is given to the satisfaction of the RO that the candidate is disqualified from being nominated as a candidate,

the RO must vary the decision to the effect that the candidate is not validly nominated. He must then publicly declare his varied decision and which candidate is or candidates are validly nominated for that constituency. The RO may not vary his decision if the candidate who has been disqualified is uncontested in his constituency and the RO has publicly declared that the candidate was duly elected [s 42B(4), (5) and (6) of the LCO].

4.35 If, after the close of nominations for an election for an FC but before the polling day, proof is given to the satisfaction of the RO that the candidate has died or is disqualified from being nominated as a candidate for the constituency, he must publicly declare that the proceedings for the election for that FC are terminated [s 42C of the LCO].

PART VI : WITHDRAWAL FROM CANDIDATURE

4.36 A candidate may withdraw his nomination by completing and signing a specified “Withdrawal of Candidature” form and lodging it with the RO concerned by not later than the last day of the nomination period [s 42 of the LCO and s 20 of the EAC (EP) (LC) Reg]. Where a candidate in a nomination list for a GC election has effectively withdrawn his candidature, the RO must strike out his name from the list and adjust the order of priority in which the names of other candidates appear on the list accordingly [s 38(6) of the LCO]. If, after the RO has determined that a nominee is validly nominated, but before the close of nominations, the RO becomes aware that the nominee has died or is disqualified from being nominated, the RO must strike out his name from the list and adjust the order of priority in which the names of other candidates appear on the list accordingly [s 38(6A) of the LCO]. After striking out a name from a list of candidates, the RO must not add the name of

any other person to the list. If no name remains on the list of candidates, the RO must reject the list. [See s 38(11), (12) and (13) of the LCO.]

IMPORTANT :

It is an offence under ss 7 and 8 of the ECICO for a person to bribe, or use or threaten to use force or duress, against a candidate to withdraw his candidature; and for a candidate to solicit or accept a bribe to withdraw his candidature.

PART VII : NOTICE OF NOMINATION

4.37 The RO for the constituency concerned will publish a notice in the Gazette within 14 days after the close of the nomination period stating the name and the principal residential address of each of all the validly nominated candidates for the constituency, together with the alphabet or number (which will be shown on the ballot paper) allocated by the drawing of lots to each candidate or list of candidates [s 21 of the EAC (EP) (LC) Reg]. Each validly nominated candidate will also be separately informed.

**PART VIII : PARTICULARS RELATING TO CANDIDATES ON
BALLOT PAPERS**

4.38 Under the PCBP (LC) Reg, candidates may, **during the nomination period**, request the EAC to print specified particulars relating to candidates on ballot papers for use in LegCo elections. These particulars

include registered names and emblems of prescribed bodies², registered emblems of prescribed persons³, words indicating that a candidate is an independent candidate or a non-affiliated candidate, and personal photographs of candidates.

Request to Print Particulars Relating to Candidates on Ballot Papers

Request by candidate for FC or a sole candidate on nomination list

4.39 A candidate for an FC or a sole candidate on a nomination list may request the EAC to print on ballot papers a personal photograph of the candidate and a choice of combinations of specified particulars - including not more than 3 registered names of prescribed bodies, not more than 3 registered emblems relating to the consenting prescribed bodies and the candidate concerned, and with or without the words “Independent Candidate” or “Non-affiliated Candidate”.

4.40 A request must be made in the specified form and signed by the requestor. Where the subject of the request relates to one or more prescribed bodies, it must be accompanied by a consent given, during the nomination period, by the body or each of the bodies in relation to the request. Where the subject of the request includes a photograph, it must be accompanied by the photograph with the name of the candidate shown on the back of the photograph.

[S 3 of the PCBP (LC) Reg.]

² A prescribed body means a prescribed political body or a prescribed non-political body.

³ A prescribed person means a person that is registered in a final register of electors for GCs as compiled and published in accordance with the LCO and that is not disqualified from being so registered or from voting at an election.

Request by candidate on nomination list with more than one candidate

4.41 A candidate on a nomination list with more than one candidate may request the EAC to print on ballot papers a personal photograph of any one or more of the candidates on the list, and a choice of combinations of specified particulars - including not more than 3 registered names of prescribed bodies, not more than 3 registered emblems relating to the consenting prescribed bodies and the candidates concerned, and with or without the words “Independent Candidate” or “Non-affiliated Candidate” against the names of the corresponding candidates.

4.42 A request must be made in the specified form and signed by the requestor and all other candidates on the nomination list concerned. Where the subject of the request relates to one or more prescribed bodies, it must be accompanied by a consent given, during the nomination period, by the body or each of the bodies in relation to the request. Where the subject of the request includes one or more photographs, it must be accompanied by the photograph or photographs with the name of the candidate concerned shown on the back of each photograph.

[S 4 of the PCBP (LC) Reg.]

Application for Registration of Name and Emblem

Application by prescribed body for the registration of its name and emblem

4.43 A prescribed body intending to support a candidate in a LegCo election may at any time apply to the EAC for the registration of all or any of the following particulars –

- (a) the Chinese name of the body;

- (b) an abbreviation of the Chinese name of the body;
- (c) the English name of the body;
- (d) an abbreviation of the English name of the body;
- (e) an emblem of the body.

4.44 An application must be made in the specified form and signed by the applicant. It should indicate that the applicant is a prescribed political body or a prescribed non-political body and that the applicant intends to consent to the subject of application being printed on a ballot paper as particulars relating to one or more persons as candidates. The application must also be accompanied by a copy of the certificate or document issued to the body by an authority or regulatory organisation that regulates the body under the laws of Hong Kong and showing the name of the body.

[S 8 of the PCBP (LC) Reg.]

Application by prescribed person for the registration of his emblem

4.45 A prescribed person intending to run in a LegCo election may at any time apply to the EAC for the registration of an emblem of the person.

4.46 An application must be made in the specified form and signed by the applicant.

[S 9 of the PCBP (LC) Reg.]

Timing of Application

4.47 Applications for registration may be submitted at any time. However, applicants should note that:

- (a) for names and emblems to be used in the 2004 LegCo election, the application must be submitted not later than 1 April 2004; and
- (b) for subsequent LegCo elections, application must be submitted not later than 15 April of each year.

Processing of Application

4.48 The EAC will process any application made by a prescribed body or a prescribed person -

- (a) if the application is made on or before 1 April 2004, as soon as practicable after that date, and in any event within 2004; or
- (b) if the application is made after the 15 April in a subsequent year, as soon as practicable after that date, and in any event within that calendar year.

[S 11 of the PCBP (LC) Reg.]

4.49 If the EAC is of the opinion that it may refuse to grant an application made by a prescribed body or a prescribed person, it must give the applicant a notice in writing. The applicant may, within 14 days after the notice is given, vary the application or make representation to the EAC on why it should not refuse to grant the application [ss 12 and 13 of the PCBP (LC) Reg].

4.50 If the EAC, having considered an application made by a prescribed body or a prescribed person, is of the opinion that it may grant the application, it will publish a notice in respect of the application in the Gazette –

- (a) specifying the name of the applicant and the subject of the application;
- (b) stating that the EAC may grant the application; and
- (c) inviting any person who objects to the granting of the application to make objection to the EAC in accordance with s 15 of the PCBP (LC) Reg.

[S 14 of the PCBP (LC) Reg.]

4.51 Under s 15 of the PCBP (LC) Reg, any person may, within 14 days after the publication of a notice in respect of an application in the Gazette, by notice in writing given to the EAC, object to the granting of the application.

4.52 In the event of an objection, the EAC will conduct a hearing. Under normal circumstances, a hearing will be held in public. However, a hearing may be held in private if it is in the interest of justice to do so. The EAC will make a decision on whether the application should be granted after hearing the representations and examining the relevant materials.

4.53 The EAC will, as soon as practicable after a decision is made to grant an application made by a prescribed body or a prescribed person, publish a notice in respect of the application in the Gazette specifying the name of the applicant and the subject of the application. If a decision is made to refuse an application, the EAC will notify the applicant in writing of the EAC's decision with reasons for its refusal. [S 19 of the PCBP (LC) Reg.]

4.54 The time needed to process an application will depend on whether an application is straightforward. If an application does not require variation and is not objected to by the public, the time required to process it will not be more than 7 weeks, if the application is made during the first registration cycle. If the application is made during any subsequent cycle, not more than 6 weeks will be required.

4.55 If an application does not meet the vetting criteria during the “preliminary processing” stage and needs to be varied, or if objection against the application is raised by the public, the total processing time may take not more than 16 weeks in the first registration cycle, and not more than 13 weeks in any subsequent cycle.

Registration and De-registration of Name, Emblem, etc.

4.56 A register of the relevant particulars in respect of the registered names and emblems of prescribed bodies and the registered emblems of prescribed persons will be established and maintained by the CEO who must make the register available for inspection, free of charge, by members of the public during ordinary business hours at the REO [s 20 of the PCBP (LC) Reg].

4.57 The EAC may de-register the name and emblem that is registered in relation to a prescribed body on the grounds that –

- (a) no request is made to print the subject of registration on ballot papers in 2 consecutive general elections or in any by-election held between such general elections; or
- (b) the body ceases to exist.

4.58 The EAC may also de-register the emblem that is registered in relation to a prescribed person on the grounds that -

- (a) no request is made to print the subject of registration on ballot papers in 2 consecutive general elections or in any by-election held between such general elections; or
- (b) the person has died.

[S 21 of the PCBP (LC) Reg.]

PART IX : PUBLICITY

4.59 After the close of nominations, the RO will inform each validly nominated candidate/list of candidate(s) the time and date on which he will draw lots to allocate a number to each candidate/list of candidate(s) to be shown on the ballot paper and they may attend if they so wish. Thereafter, the REO will publish a brief introduction of the candidates in the form of a leaflet. The number of each candidate or list of candidate(s) on the ballot paper allocated to him or the list by the drawing of lots will also be shown on this introductory leaflet. The leaflet will be mailed to the electors close to the time of the polling day.

4.60 Candidates are free to make use of this introductory leaflet to promote themselves. Any candidate who so wishes should submit the following to the relevant RO **before the close of the nominations:**

- (a) an introductory message in a specified form provided by the RO;
and

- (b) 5 identical copies of his photograph with his name on the back which must be of passport size, in colour and taken within the last 6 months.

4.61 The contents, nature and presentation of the candidates' messages in the introductory leaflets are exclusively the idea and work of the candidate himself. They will not be subject to alteration or edition by the REO unless they are considered to be indecent, defamatory or in any other way unlawful. Candidates are reminded that some electors are only able to read English.

CHAPTER 5

POLLING AND COUNTING ARRANGEMENTS

PART I : BEFORE THE POLL

5.1 For each of the 5 GCs, a number of polling stations situated within the GC will be designated. The polling stations designated for the GCs will be used also for polling for the 24 ordinary FCs and 4 SFCs (a combined polling arrangement). The polling stations will be converted to counting stations for counting the GC ballot papers. A central counting station will be set up for counting the ordinary FC and SFC ballot papers and any misplaced GC ballot papers found in FC/SFC ballot boxes at the central counting station.

5.2 The CEO may designate the same place as a polling station and a counting station. He will designate a polling station at which less than 200 electors are assigned to vote as a small polling station. He will designate one polling station as a main counting station for the purpose of counting the votes of the small polling station. The aggregate of the electors assigned to vote at the polling station to be designated as the main counting station and the electors assigned to vote at the small polling station must not be less than 200. [S ___ of the EAC (EP) (LC) Reg.] The RO will, at least one working day before the polling day, give notice to each candidate of the place or places at which vote counting is to take place for the constituency contested by the candidates [s ___ of the EAC (EP) (LC) Reg].

5.3 An area outside the polling station will be designated as the No Canvassing Zone (“NCZ”) and No Staying Zone (“NSZ”), the boundaries of which will be determined by the RO. All candidates will be notified of these

zones before the polling day [s 43 of the EAC (EP) (LC) Reg]. The RO may also authorise the PRO to vary the NCZ or NSZ on the polling day [s 92 of the EAC (EP) (LC) Reg]. [See Chapter 14 : Prohibition Against Canvassing Activities Outside Polling Station.]

5.4 A polling station for a GC is normally situated within the boundaries of the constituency, but where there are no suitable premises for use within the GC, polling stations will have to be designated in nearby areas outside the constituency. Where circumstances require, non-permanent structures may be designated as polling stations. The polling stations designated for the 5 GCs are localised in the sense that an elector of a particular GC will be assigned to a polling station close to his principal residence as shown on the final register of electors.

The Combined Polling Arrangements

5.5 Combined polling arrangements will be made so as to convenience all electors. The arrangements are for providing a one-stop service to each and every elector, no matter whether he is entitled to vote in the GC, an ordinary FC or an SFC, or two or more of them, so that he needs only to attend **ONE** polling station to cast all his votes. There are the following scenarios:

- (a) an elector who is only entitled to cast a GC vote: he will be allocated to a polling station designated for that GC for casting his GC vote;
- (b) an ordinary FC/SFC elector or AR of a corporate elector of one of the ordinary FCs/SFCs: he will be allocated to the polling station designated for his GC, in which he can at the same time cast his

GC vote, his ordinary FC/SFC elector vote or his ordinary FC/SFC AR vote; and

- (c) an elector of an ordinary FC/SFC who may be at the same time an AR of another ordinary FC/SFC: he will be allocated to the polling station designated for his GC, in which he can at the same time cast his GC vote, his ordinary FC/SFC vote as elector and his ordinary FC/SFC vote as AR.

[S 30 of the EAC (EP) (LC) Reg.]

5.6 Owing to the fact that combined polling arrangements are used, special arrangements regarding poll cards, ballot papers, cardboards and ballot boxes may be required, so as to help prevent confusion and mistake at polling, avoid breaking the secrecy of the vote, and facilitate sorting of ballot papers at the count.

5.7 The **ballot papers** for each of the 5 GCs, each of the 24 ordinary FCs and each of the 4 SFCs will be made easily distinguishable by way of one or more of the following ways, namely, size, colour, colour pattern and code. This will help prevent confusion and mistake at polling, and will facilitate sorting of ballot papers at the count. The **poll card** (notifying the elector/AR of the polling station he must attend to cast his vote or votes) sent to the elector/AR shortly before the polling day will bear the same colour as that used for the cardboard referred to in para. 5.9 below, depending on the number of ballot papers he is entitled to be issued to him in the polling station.

5.8 **Ballot boxes** in different colours are provided in a polling station: a white ballot box for receiving the GC ballot papers and a red ballot box for receiving the ballot papers for the FCs/SFCs (mixed).

5.9 In order to ensure that no elector or AR will leave the polling station with any ballot paper, a **colour cardboard** will be given to him at the same time when ballot paper(s) are issued to him. The colour of the cardboard depends on how many ballot papers are issued to the elector according to his entitlement: **white** for an elector issued with one ballot paper, **red** for one issued with 2 ballot papers and **blue** for one issued with 3 ballot papers.

[Please see **Appendix D** for details of the combined polling arrangements mentioned in the preceding 5 paragraphs.]

5.10 About 10 days before the polling day, electors of contested constituencies will be sent poll cards, addressed to their last addresses known to the REO, notifying them of the date, time and place of the poll [s 31 of the EAC (EP) (LC) Reg]. In the case where the number of validly nominated candidates for a constituency does not exceed the number of vacancies, the candidate(s) will be declared elected [s 46 of the LCO]. Electors in respect of such a constituency do not need to vote, and a notice to that effect will be sent to them. The polling stations designated for the constituency will not be used for polling in respect of that constituency.

5.11 An elector (and an AR of a corporate elector) **may vote only at the polling station allocated to him** by the CEO. Many of the polling stations are accessible to persons with a disability including those who have difficulty in walking. An elector with a disability finding it difficult for him to access the polling station allocated to him may **at least 5 days** before the polling day apply to the CEO for re-allocation of a polling station specifically designated for such electors (“special polling station”) [s 33 of the EAC (EP) (LC) Reg]. If a special polling station is re-allocated to him, then he can vote only at that polling station. In case circumstances require, the CEO may allocate an alternative polling station or alternative special polling station to an

elector in addition to or in substitution of the one originally allocated to him. [S 30(4A) of the EAC (EP) (LC) Reg.] Electors concerned can make enquiries with the REO on this subject by telephone or facsimile.

PART II : INSIDE THE POLLING STATION

5.12 About 15 minutes before the commencement of polling, which is at **7:30 am** on the polling day, the PRO at a polling station will show the candidates, their election agents and polling agents, if they are present, the empty ballot boxes before proceeding to lock and seal them. Candidates concerned and their agents may observe the locking and the sealing of the ballot boxes.

5.13 The PRO will also inform and show to the candidates, their election agents and polling agents, if they are present, the number of unissued ballot papers relating to the constituency, which are in his possession.

5.14 In the polling stations, there will be different sets of ballot papers and ballot boxes to prevent confusion and mistake. For ballot papers, there will be 29 different sets, 1 for the particular GC for which the polling station is designated, 1 for each of the 24 FCs and 1 for each of the 4 SFCs. For ballot boxes, there will be 2 different sets, 1 (white in colour) to hold the ballot papers cast for the GCs and the other (red in colour) to hold the ballot papers cast for the FCs/SFCs (mixed).

5.15 The GC and FC ballot papers are easily distinguishable by different colour patterns, sizes or code numbers, at the back and/or in the front, to facilitate easy identification in the polling and counting process.

PART III : OUTSIDE THE POLLING STATION

5.16 Where circumstances permit, the PRO will arrange an enlarged copy of the relevant introductory leaflets on candidates published by the REO to be displayed outside the polling station to facilitate easy reference by electors. A NCZ will be designated outside each polling station to ensure the free and safe passage of electors into the polling station. Door-to-door canvassing and, for the purpose of such canvassing, the display of any propaganda material, eg any badge, emblem, clothing or head-dress, which may promote or prejudice the election of a candidate or candidates at the election, or makes direct reference to a body any member of which is standing as a candidate in the election or a prescribed body which has given consent to its registered name or emblem to be printed on any ballot paper [see paras. 4.38 to 4.42 above], will be allowed on the storeys above or below street level in a building within a NCZ other than a building in which there is a polling station, provided that permission has been obtained for entry to the building for canvassing votes, obstruction is not posed to electors and no amplifying system or device is used. Apart from this, no other canvassing activities or display of EAs will be allowed within a NCZ except for static display of EAs that are authorised by the RO or the PRO of the relevant polling station. A notice of the declaration of a NCZ and a map or plan showing the boundary of the area will be put up at or near the polling station. A NSZ in which no one is allowed to stay or loiter will also be designated immediately outside the entrance of a polling station to avoid any obstruction of entry. [See Chapter 14 : Prohibition Against Canvassing Activities outside Polling Stations.]

5.17 On the polling day, a person must not:

- (a) other than the door-to-door canvassing activities stated in para. 5.16 above, engage in canvassing votes within the NCZ;
- (b) use a sound amplifying system or device for any purpose within the NCZ;
- (c) use a sound amplifying system or device, or conduct any activity (eg lion dance) for canvassing votes, so that the sound emitted by it can be heard in the NCZ;
- (d) without any reasonable excuse, display in the NCZ any propaganda material, eg any badge, emblem, clothing or head-dress, which:
 - (i) may promote or prejudice the election of a candidate or candidates at the election; or
 - (ii) makes direct reference to a body any member of which is standing as a candidate in the election or a prescribed body which has given consent to its registered name or emblem to be printed on any ballot paper; or
- (e) stay or loiter in the NSZ without the express permission of the PRO;

otherwise he commits an offence and will be liable to a fine at level 2 (up to \$5,000) and imprisonment for 3 months [ss 40 and 45 of the EAC (EP) (LC) Reg].

PART IV : ADMISSION TO THE POLLING STATION

5.18 Other than electors, the following persons may also be admitted to a polling station:

- (a) the PRO and other polling staff;
- (b) members of the EAC;
- (c) the CEO;
- (d) the ROs and Assistant Returning Officers (“AROs”) for the relevant constituency;
- (e) public officers on duty at the polling station, including police officers and members of the Civil Aid Service;
- (f) candidates and election agents of the relevant constituency;
- (g) polling agents for the polling station (only one at a time in respect of each candidate);
- (h) public officers authorised in writing by the CEO;
- (i) any person authorised in writing by a member of the EAC, subject to the conditions as imposed in the authorisation;
- (j) a person authorised in writing by the RO for liaison purposes;
and

- (k) a child who accompanies an elector to the polling station for the purpose of voting (if the PRO considers that the child should not be left unattended while that elector is inside the polling station).

[S 44 of the EAC (EP) (LC) Reg.]

A notice will be displayed at the entrance to polling stations to show that only the above persons and electors may be allowed to enter.

NOTE :

For the purpose of ensuring that polling takes place smoothly and efficiently, the PRO may regulate the number of electors, candidates, election agents and polling agents to be admitted to the polling station at any one time. Only one such person may be present in the polling station: a candidate or his election agent or his polling agent. [See also Chapter 7 : Appointment and Roles of Election Agent, Election Expense Agents, Polling Agents and Counting Agents.]

5.19 Except for an elector or a police officer on duty or a member of the Civil Aid Service on duty, all other persons permitted to enter a polling station are required to sign a **Declaration of Secrecy** on a specified form and observe the provisions governing the secrecy of voting [s 95 of the EAC (EP) (LC) Reg].

PART V : CONDUCT INSIDE THE POLLING STATION

5.20 The polling stations designated for the 5 GCs which will also serve the 24 ordinary FCs and 4 SFCs will have polling arrangements designed to convenience electors. Inside each of such polling stations, a notice will be displayed to inform electors that polling for the relevant GC, all the 24 ordinary FCs and all the 4 SFCs is being held concurrently, and that an elector will be issued with 1, 2 or 3 **different ballot papers**, depending on his entitlement. **The ballot papers** issued to the elector so entitled **will be issued at the same time**. Therefore, such an elector who wishes to exercise the right to cast any of his votes will have to do so at the **same visit** to the polling station.

5.21 On arrival at the polling station, an elector or AR should show to the polling staff at the ballot paper issuing desk his identity card or such other identity document or documents, which show the identity card/document number, name and photograph of the elector, to the satisfaction of the PRO. The polling staff will check the elector/AR's identity document against the entries on the copy of register of electors to ascertain if the elector/AR is registered in respect of both the GC, and one or two of the 24 ordinary FCs and the 4 SFCs. If so, the polling staff will inform him accordingly. The polling staff will call out the name of the elector/AR as stated in the entry in the copy of the composite or annotated register of electors and cross out the name and the identity document number of that entry, before giving him either 1 or 2 or 3 different ballot papers, as appropriate. An elector/AR may be asked to check his own entry on the register to ensure that he has been given the correct ballot paper(s). No record will be made as to which particular ballot paper is given to an elector/AR.

5.22 For control purpose regarding the total number of ballot papers issued, the counterfoil of each ballot paper bears a serial number on its front.

The serial number on the counterfoil will not, however, be recorded or related to the particular elector to whom the ballot paper is issued.

5.23 If there is reasonable ground for questioning the bona fides of an elector, the PRO shall ask him the following questions at the time of his application for a ballot paper (but not afterwards):

- (a) Are you the person registered in the final register now in effect for this GC and/or FC/SFC (as appropriate), as follows (reads the whole of the relevant entry in the register)?
- (b) Have you already voted for this or any other GC and/or FC/SFC (as appropriate) in this election?

The person will not be issued with any ballot paper unless he has answered the questions to the satisfaction of the PRO. [S 51(3) and (4) of the EAC (EP) (LC) Reg.]

5.24 Where there is reasonable cause to believe that a person has committed an offence of impersonation of an elector, the PRO may request the police officer on duty at the polling station to arrest that person [s 52 of the EAC (EP) (LC) Reg].

5.25 If an elector has been issued with a ballot paper but chooses not to take it, he cannot return to the polling station later and claim for that or another one. If, after having been issued with a ballot paper, an elector has become incapacitated by physical illness and has left the polling station without marking his ballot paper, he may return to the polling station to cast his vote before the close of poll, provided that before he leaves the polling station, his ballot paper has been retrieved by the PRO. Under the above circumstances, the PRO must keep that ballot paper in his custody and re-issue it, in the

presence of a police officer, to the elector in question when the latter returns before the close of poll to cast his vote. But if at the close of poll, the elector has not returned, the PRO shall endorse the ballot paper with the word “**UNUSED**” and deal with it accordingly. [Ss 61 and 80 of the EAC (EP) (LC) Reg.]

5.26 The PRO would need to keep a ballot paper left in the polling station in his custody in the circumstances described in para. 5.25 above only when he knows which elector had left the ballot paper behind. Otherwise, a ballot paper found to be left in the polling station should be regarded as “unused” and would not be counted.

5.27 When issued with ballot paper(s), an elector/AR will also be provided with a cardboard to which a chop with a tick “✓” is attached. Persons who are supplied with one ballot paper will be required to carry a **white** cardboard to show that they have only one ballot paper. Persons who are issued with 2 ballot papers will be required to carry a **red** cardboard, and those who are issued with 3 ballot papers will be required to carry a **blue** cardboard. This arrangement is to facilitate control and monitoring so that no person can take away any ballot paper from the polling station. The cardboard will be collected by the polling staff after the elector/AR has inserted his ballot paper(s) into the ballot box(es) before leaving the polling station.

5.28 After being issued with the ballot paper(s)/the cardboard to which a chop with a tick “✓” is attached, the elector/AR should immediately proceed to one of the voting compartments where he should mark his ballot paper(s) to indicate his choice of candidate(s). The manner in which a ballot paper should be marked for the GC, the 24 ordinary FCs and the 4 SFCs will be different, depending on the applicable voting system. An elector/AR should read carefully the instructions given on the ballot paper and follow the instructions in marking his choice of candidate(s).

5.29 Briefly, in respect of a GC ballot paper to which the list system of proportional representation is applicable, the elector has only one vote and he must affix the chop supplied to give only one “✓” against the list containing one or more candidates’ names (as opposed to an individual candidate’s name) of his choice in the circle provided. In respect of a ballot paper regarding the 24 ordinary FCs to which the first past the post voting system applies, the elector/AR is entitled to cast one vote and should indicate his choice of candidate of the relevant FC by giving one “✓” against the candidate of his choice in the circle provided, save in the Labour FC which has 3 vacancies to fill, then the elector may give a “✓” against the names of up to 3 candidates. The ballot paper regarding the 4 SFCs to which the preferential elimination voting system applies will have all the candidates’ names printed on it together with circles against each name for the elector or the AR of the corporate elector to mark his choices of preference. He should mark the ballot paper to indicate his preference, by writing **Arabic numerals** in the circle opposite the names of the candidates, in descending order of preference, ie:

- (a) writing “1” in the circle opposite the name of the candidate of his first preference (“first preference vote”);
- (b) writing “2” in the circle opposite the name of the candidate of his second preference;

and so on. **An elector/AR must mark a first preference vote.** He may, if he wishes, mark second, third and subsequent preferences for as many candidates as are indicated on his ballot paper.

5.30 For an elector of the GC, after he has marked the ballot paper(s) to indicate his choice of the list of candidate, he should **keep the ballot paper as folded to conceal the marking(s) thereon.** For an elector/AR of the

FCs/SFCs, he must **not fold his ballot paper** before inserting it face down into the ballot box.

5.31 Immediately after an elector/AR has come out of the voting compartment, he should insert the GC ballot paper into the white ballot box and the FC/SFC ballot paper(s) face down into the red FC/SFC ballot boxes as directed by the polling staff. The elector/AR should then return the cardboard and the chop to the polling staff and leave the polling station immediately.

NOTE :

An elector/AR must not remove a ballot paper from a polling station. It is an offence under s 54(6) of the EAC (EP) (LC) Reg for a person to bring out a ballot paper from a polling station. Any person who removes a ballot paper from a polling station with an intent to deceive may commit an offence under s 17(1)(c) of the ECICO and may be prosecuted. It will also be a corrupt conduct under s 17(1)(d) of the ECICO if any person, without lawful authority, destroys, defaces, takes or otherwise interferes with a ballot paper at the election.

5.32 A visually impaired elector who so requests will be provided with a **template** to facilitate his marking of the ballot paper without any assistance from anyone [s 59(3) of the EAC (EP) (LC) Reg]. [For details about the template, see para. 7.36 of Chapter 7.] The template should be returned to the polling staff after use.

5.33 **The ballot is secret. No one can force a person to vote or not to vote for any particular candidate** [s 13 of the ECICO]. **Also no one is required to tell which candidate he has voted for or is going to vote for.** A person who, without lawful authority, requires or purports to require an elector

to disclose the name of, or any particular relating to, the candidate for whom the elector voted commits an offence [s 60 of the LCO].

5.34 Any elector/AR who has inadvertently torn or damaged any ballot paper or has made an error in marking any ballot paper issued to him may ask the PRO to exchange it for another unmarked ballot paper. Such spoiled ballot papers will be endorsed on the front with the word “**SPOILT**” and will be kept by the PRO. The spoiled ballot papers will not be counted at the counting of the votes. [Ss 62 and 80 of the EAC (EP) (LC) Reg.]

5.35 Where a person, representing himself to be a particular elector or AR of a corporate elector entered on the register, applies for any ballot paper after a person has been issued with any ballot paper as such an elector or AR, he may be issued with a ballot paper with the word “**TENDERED**” endorsed on the front. Such a ballot paper shall not be counted at the counting of the votes. [Ss 60 and 80 of the EAC (EP) (LC) Reg.] However, if an elector or AR who has been issued with a ballot paper chooses not to cast his vote and leaves the polling station and returns later to claim for that or another ballot paper, the PRO may issue a tendered ballot paper to the elector **ONLY IF** he is not certain that the elector is the one who has been issued with a ballot paper earlier.

5.36 Ballot papers which have been issued (whether marked or unmarked) are sometimes abandoned or found left behind by electors/ARs in the voting compartments or lying on the floor of the polling station, or otherwise not used. The intention of the electors/ARs is not clear in such cases. Any person who discovers such a ballot paper is required to hand it to the PRO. Such a ballot paper will be endorsed on the front with the word “**UNUSED**” (unless it is not reasonably practicable to do so) and will be kept by the PRO. In no circumstances will the ballot paper be put into a ballot box.

Such a ballot paper will not be counted at the counting of the votes. [Ss 61 and 80 of the EAC (EP) (LC) Reg.]

5.37 An elector/AR who is unable to mark a ballot paper to indicate the choice of candidate (eg being unable to read or write or incapacitated by visual deficiency or other physical cause) may ask the PRO, Deputy PRO or Assistant PRO to mark the ballot paper on his behalf. The marking of the ballot paper will be made to show the elector's choice in the presence of one of the Polling Officers as a witness. [S 59 of the EAC (EP) (LC) Reg.]

5.38 Inside a polling station, an elector/AR must not:

- (a) interfere with or attempt to influence any other elector/AR;
- (b) speak to or communicate with any other elector/AR if the RO, ARO, PRO, Deputy PRO or any Assistant PRO has given direction to him not to do so;
- (c) attempt to obtain information, or disclose any knowledge acquired, concerning the vote of another elector/AR;
- (d) exhibit or distribute any campaign material;
- (e) without any reasonable excuse, display any propaganda material, eg any badge, emblem, clothing or head-dress, which:
 - (i) may promote or prejudice the election of a candidate or candidates at the election; or
 - (ii) makes direct reference to a body any member of which is standing as a candidate in the election or a prescribed body

which has given consent to its registered name or emblem to be printed on any ballot paper; or

- (f) use a mobile telephone or any telephone or paging machine or any other form of electronic communication device if the RO, ARO, PRO, Deputy PRO or any Assistant PRO has given direction to him not to do so.

If a person contravenes any of the above prohibitions, he commits an offence and will be liable to a fine at level 2 (up to \$5,000) and imprisonment for 3 months [see s 45 of the EAC (EP) (LC) Reg].

5.39 A person must not misconduct himself at a polling station or its vicinity or fail to obey any lawful order of the RO or the PRO; otherwise he commits an offence punishable with a fine and imprisonment and may be ordered by such officer to leave the polling station or the vicinity of the polling station. A person misconducts himself if he disrupts the poll or disturbs or causes inconvenience to any person in the polling station. If he fails to leave immediately as ordered by the RO or the PRO, he may be removed by a police officer or by any other person authorised in writing by the RO or the PRO to remove him. The person so removed may not re-enter the polling station during that day except with the permission of the RO or the PRO [s 46 of the EAC (EP) (LC) Reg].

5.40 Only the following persons may speak to or communicate with electors/ARs inside a polling station:

- (a) the PRO and other polling staff;
- (b) members of the EAC;

- (c) the CEO;
- (d) the ROs and AROs for the relevant constituency;
- (e) police officers and members of the Civil Aid Service on duty at the polling station;
- (f) a person authorised in writing by the ROs for liaison purposes; and
- (g) a person authorised in writing by a member of the EAC.

[S 45(1) and (6) of the EAC (EP) (LC) Reg.]

5.41 No person may canvass or display any EA within a polling station. Any person who undertakes photographing, filming and video or audio recording within a polling station without the express permission of the PRO, the RO for the constituency or constituencies for which the polling station is used or a member of the EAC, commits an offence [s 45(2) of the EAC (EP) (LC) Reg]. Normally such permission is only granted to members of the media or government photographers for publicity purposes.

PART VI : CLOSE OF POLL

5.42 Polling will close at **10:30 pm**, and electors who intend to vote but are not at the door of their designated polling station by that time will not be allowed in afterwards. At the close of poll, the ballot boxes will be locked and sealed by the PRO in the presence of the relevant candidates and their agents, if they are present. The PRO will also inform them the numbers of

unissued ballot papers, spoiled ballot papers and unused ballot papers in his possession. All ballot papers which are unissued, spoiled or unused and the marked copies of the registers will then be made up into sealed packets in respect of each constituency.

5.43 The polling stations set up for each of the 5 GCs (except the small polling stations) will be converted to counting stations for the purpose of conducting the count. A central counting station will be set up to conduct the count for the 24 ordinary FCs and 4 SFCs and for any misplaced GC ballot papers found in FC/SFC ballot boxes at the central counting station.

A Polling Station other than a Small Polling Station

5.44 At the close of poll, a notice will be displayed by the PRO outside the polling station (which is also designated as a counting station) to inform the public that the poll has been closed and that the station is being arranged for the counting of GC votes and will be open to them when such arrangements are completed. A candidate and his election agent and counting agent may stay in the polling station while it is closed for the preparation for the counting of GC votes.

5.45 The sealed ballot boxes and sealed packets of unissued ballot papers etc will be kept by the PRO until the counting of the GC votes begins, when all GC ballot boxes will be opened and all ballot papers inside will be put on the counting table. For the counting of FC/SFC votes, the sealed ballot boxes and sealed packets of unissued ballot papers, together with any FC/SFC ballot papers found to have been misplaced in GC ballot boxes (see para. 5.53 below) etc will be delivered to the central counting station. Up to 2 persons being candidates competing in the FCs/SFCs (or their respective agents), if they so wish, will be allowed to accompany the Deputy PRO/Assistant PRO in the delivery of the ballot boxes from the polling station to the central counting

station. Where there are more than 2 such persons wishing to participate in the delivery, the PRO will draw lots to determine which 2 persons will participate. FC/ SFC candidates and their agents are allowed to remain in the polling station only until they see that the police escort for the delivery is available. Thereafter, all of them, except those 2 persons who are to participate in the delivery, must leave the polling station.

A Small Polling Station

5.46 At the close of poll, a notice will be displayed by the PRO outside the polling station to inform the public that the poll has been closed. A candidate and his election agent and polling agent may stay in the polling station while it is closed.

5.47 For the small polling stations which have not been designated as counting stations for GC votes, the sealed ballot boxes and sealed packets of unissued ballot papers etc for the GCs and FCs/SFCs will be first delivered to the main counting station by the PRO/Deputy PRO under police escort. The FC/SFC ballot boxes, together with any misplaced FC/SFC ballot papers found inside the GC ballot boxes, will then be delivered to the central counting station for counting [see paras. 5.53 and 5.63 below for details]. Not more than 2 candidates or their agents, if they so wish, will be allowed to participate in the delivery. Where there are more than 2 such persons wishing to participate in the delivery, the PRO will draw lots to determine which 2 persons will participate. Candidates and their agents are allowed to remain in the polling station only until they see that the police escort for the delivery is available, and thereafter all of them, except those 2 persons who are to participate in the delivery, must leave the polling station.

PART VII : THE COUNT

5.48 A polling station, other than a small polling station which has not been designated as a counting station for GC votes, will be converted to a counting station for the purpose of conducting the count for GC votes and making known the counting results to the candidates and their agents present. The PRO, assisted by his Deputy PROs, Assistant PROs and counting staff, will be responsible for the conversion and the conduct of the count. Before the counting of votes begins, a notice will be displayed outside the counting station to inform the public the time that the station is expected to be open to them to observe the counting of votes [s ___ of the EAC (EP) (LC) Reg]. For FC/SFC votes, a central counting station will be set up to conduct the count and announce the election results. The RO for each FC, assisted by his AROs and counting staff will be responsible for the conduct of the count. An RO will be designated for each of the 5 GCs. The 5 ROs will be stationed at the central counting station. Each RO will be assisted by a number of AROs to compile the final election results of the respective GC by adding up counting results from polling stations under his charge.

Conduct at the Counting Station

5.49 Only the following persons may be present at the counting of votes at the counting zone of a counting station or the central counting station:

- (a) the ROs, AROs, PROs, Deputy PROs, Assistant PROs and counting staff for the relevant constituencies;
- (b) members of the EAC;
- (c) the CEO;

- (d) candidates and their election agents and counting agents of the relevant constituencies;
- (e) police officers and members of the Civil Aid Service on duty at the counting station;
- (f) public officers authorised in writing by the CEO;
- (g) any person authorised by the RO or the PRO; and
- (h) any person authorised in writing by a member of the EAC.

The PRO or the RO, as the case may be, will designate a restricted zone inside the counting zone where the counting staff will count the votes. Candidates and their agents must not go into the restricted zone. Any member of the public may observe the counting of the votes from an area (“the public area”) at the counting station set apart for that purpose by the PRO or the RO, unless the PRO or the RO considers that his presence may:

- (a) cause disorder or disturbance in the counting station; or
- (b) prejudice the secrecy of the individual votes.

[S 68 of the EAC (EP) (LC) Reg.]

5.50 Before entry, every person authorised to be present at a counting station, other than the police officers and members of the Civil Aid Service on duty, must make a **Declaration of Secrecy** on a specified form and observe the provisions governing the secrecy of voting [s 95 of the EAC (EP) (LC) Reg]. Members of the public present within the public area will not be required to make a Declaration of Secrecy.

5.51 Except with the express permission of the relevant PRO or RO or a member of the EAC, as the case may be, any person who undertakes photographing, filming and video or audio recording within a counting zone of a counting station during the period commencing from the time at which the counting of the votes is to begin at the zone and ending upon the completion of the counting and re-count, if any, at the zone commits an offence [s 68A(1) and (2) of the EAC (EP) (LC) Reg].

5.52 A person must not misconduct himself in or in the vicinity of a counting station or fail to obey any lawful order of the PRO or the RO; otherwise he commits an offence punishable with a fine and imprisonment and may be ordered by the PRO or the RO to leave the area. A person misconducts himself if he disrupts the counting of votes or disturbs or causes inconvenience to any person in the counting station. The PRO or the RO may also order a person to leave the counting station if the person conducts himself in such way that the purpose of his presence is not that for which he was authorised or permitted to enter or remain in the counting station. If he fails to leave immediately, he may be removed by a police officer or by any other person authorised in writing by the PRO or the RO to remove him. The person so removed may not re-enter the counting station during that day except with the permission of the PRO or the RO [ss 68A and 69 of the EAC (EP) (LC) Reg].

(a) **Counting of GC votes**

5.53 The PRO will check whether all the ballot boxes are properly sealed. The seal on each GC ballot box will then be broken by the PRO in the presence of the candidates or their election or counting agents, if they are present at the time. All GC ballot boxes will then be opened and the contents emptied onto a counting table. The candidates and their election or counting agents may request to inspect any papers other than ballot papers taken out

from the ballot boxes before they are disposed of. If the PRO identifies any misplaced FC/SFC ballot papers, the PRO will seal the misplaced FC/SFC ballot papers and then arrange to deliver them, together with the sealed FC/SFC ballot boxes, to the relevant RO of the central counting station for counting. The PRO will then conduct the count of the GC ballot papers in the presence of the candidates, or their election or counting agents, if they are present. **At no time should a candidate, his election agent or counting agent touch any ballot papers.**

5.54 The PRO other than the PRO of a main counting station will:

- (a) sort the ballot papers according to the choices marked by the electors on the ballot papers and place them in separate transparent boxes on the table;
- (b) separate, count and put aside the invalid and questionable ballot papers, if any;
- (c) determine the validity of questionable ballot papers;
- (d) count the valid votes obtained by each candidate;
- (e) verify the ballot paper account; and
- (f) compile the final counting results.

5.55 The PRO of a main counting station will:

- (a) count and record the number of ballot papers in each ballot box of the polling station designated as the main counting station and

of such ballot box that has been delivered from the small polling stations;

- (b) verify the ballot paper account;
- (c) mix the ballot papers of the polling station designated as the main counting station together with the ballot papers that have been delivered from the small polling stations;
- (d) sort the ballot papers according to the choices marked by the electors on the ballot papers and place them in separate transparent boxes on the table;
- (e) separate, count and put aside the invalid and questionable ballot papers, if any;
- (f) determine the validity of questionable ballot papers;
- (g) count the valid votes obtained by each candidate; and
- (h) compile the final counting results.

[Ss _____ of the EAC (EP) (LC) Reg.]

Invalid Ballot Papers

5.56 A ballot paper is invalid if:

- (a) no vote has been marked on it;
- (b) it is not marked with the chop provided;

- (c) it is endorsed on the front with the word “SPOILT”;
- (d) it is endorsed on the front with the word “TENDERED”;
- (e) it is endorsed on the front with the word “UNUSED”; and
- (f) votes are given for more than one list of candidates for a GC (eg by marking a “✓” each against 2 lists of candidates).

These ballot papers will be counted as invalid on the spot. They will not be counted and need not be treated as questionable ballot papers. A candidate, an election agent or a counting agent is not entitled to make representations to the PRO concerning these ballot papers. [S 80 of the EAC (EP) (LC) Reg.]

Questionable Ballot Papers

5.57 Ballot papers with doubtful validity in the following areas are set aside as questionable ballot papers. A questionable ballot paper will be decided as invalid if in the opinion of the PRO:

- (a) it has any writing or mark by which the elector can possibly be identified;
- (b) it is not marked by affixing the chop to give a single “✓” in the circle opposite the list of candidates of the elector’s choice on the ballot paper, and the elector’s intention is unclear. (However, the PRO may count that ballot paper if he is satisfied that the elector’s intention is clear);
- (c) it is substantially mutilated; and

- (d) it is void for uncertainty.

[S 81(3) of the EAC (EP) (LC) Reg.]

5.58 The validity of all questionable ballot papers shall be decided by the PRO after considering the representations, if any, concerning the ballot papers by the candidate or his election agent or counting agent. Before the PRO makes his decision, a candidate or his election agent or counting agent, if present at the counting zone, may inspect the questionable ballot papers as set aside, in the presence of the PRO and other candidates or their election or counting agents who are present. A candidate or his election agent or counting agent may object to the admission or rejection of a questionable ballot paper by making his objection known to the PRO who has decided whether the ballot paper (or the vote recorded thereon) is valid or to be rejected and, in the latter event, endorse on the ballot paper the word “rejected”. [S 81 of the EAC (EP) (LC) Reg.]

5.59 A candidate or his election agent or counting agent may object to the rejection of a ballot paper by the PRO, in which case the PRO shall add to the endorsement the words “rejection objected to”. Questionable ballot papers which are accepted by the PRO but objected to by a candidate or his election agent or counting agent will be marked “acceptance objected to”. [S 81 of the EAC (EP) (LC) Reg.]

5.60 The decision of the PRO in regard to any question arising in respect of any ballot paper shall be final [s 82 of the EAC (EP) (LC) Reg], and may only be questioned by an election petition [s 61 of the LCO] [see Part II of Chapter 6].

5.61 The counting of the votes will proceed continuously, as far as possible, until the counting is completed.

5.62 When vote counting is completed at any one of the counting stations for the constituency, the relevant PRO will inform the candidates and their election or counting agents present of the counting results. Any such candidate or his election agent or his counting agent may request the PRO to re-count the votes and the PRO shall comply with the request unless in his opinion it is unreasonably made. Where there is no request for a re-count or where the request for a re-count is rejected or the re-count is completed and there is no request for a further re-count or the request for a further re-count has been rejected by the PRO, the PRO will inform the candidates and their election or counting agents present of the counting results. The PRO shall report to an ARO for the constituency at the central counting station of the counting results. Any misplaced GC ballot papers found in FC/SFC ballot boxes at the central counting station and delivered to the relevant RO will be counted by the RO. The validity of any questionable ballot papers will be determined by the RO. Candidates, their election agents or counting agents present may raise objection to the admission or rejection of a questionable ballot paper. The RO's decision on the validity of the ballot paper is final. The counting arrangement as set out in paras. 5.56 to 5.60 above will be followed by the RO. If a candidate or his election agent at the central counting station requests the RO to re-count all the votes of all the counting stations for the constituency, the RO will decide whether the request should be acceded to. If he decides that such a re-count is reasonable in the circumstances, he will inform the PROs of all the counting stations for the constituency to conduct a re-count at their respective counting stations. [S 79 of the EAC (EP) (LC) Reg.]

(b) Counting of FC/SFC votes

5.63 The FC/SFC ballot boxes will first be delivered to the central counting station, together with any FC/SFC ballot papers found to have been misplaced in GC ballot boxes, and will be given into the charge of the relevant

ARO. Each ballot box will then be checked to see if it is properly sealed. The seal on the ballot box will be broken by the relevant ARO in the presence of the relevant candidates or their election agents or counting agents, if they are present at the time. The ballot box will then be opened and the contents emptied onto a counting table. Any misplaced GC ballot papers found will be sealed and then delivered to the RO of the relevant GC for counting. **At no time should a candidate, his election agent or counting agent touch any ballot papers.**

5.64 There will be a large number of sorting/counting zones for the ordinary FCs and SFCs. The ballot papers (but not the votes marked on them) for the ordinary FCs/SFCs from each of the polling stations will first be counted for verification of the ballot paper accounts by the counting staff. Such ballot papers will be separately bundled with the respective verified ballot paper account.

5.65 The ordinary FC/SFC ballot papers in each of the sorting/counting zones will be sorted to make up separate bundles for each constituency. Each bundle of ballot papers which is required to be delivered to another sorting/counting zone will be placed in a separate receptacle and sealed under observation by persons present at the counting station. Bundles belonging to the same constituency will be allocated to the AROs and their staff for transferring them to the counting zones in respect of the relevant constituency for the counting of votes marked on them under the supervision of the RO of the ordinary FC/SFC. The ballot papers for the same ordinary FC/SFC from not less than 2 of the polling stations will first be mixed before counting.

Invalid Ballot Papers

5.66 A ballot paper is invalid if:

- (a) no vote has been marked on it;
- (b) it is endorsed on the front with the word “TENDERED”;
- (c) it is endorsed on the front with the word “SPOILT”;
- (d) it is endorsed on the front with the word “UNUSED”;
- (e) in respect of an ordinary FC ballot paper, it is not marked with the chop provided;
- (f) for an ordinary FC, votes are marked for more than the number of vacancies to be filled (in respect of the Labour FC, a ballot paper is invalid if more than 3 votes are marked on it; in respect of the other 23 FCs, a ballot paper is invalid if more than 1 vote is marked on it);
- (g) in respect of a SFC ballot paper, it is not marked by Arabic numerals;
- (h) for a SFC, votes are marked with a first preference for 2 or more candidates (whether or not the elector marks second, third or subsequent preferences); and
- (i) for a SFC, votes are not marked with a first preference (whether or not the elector marks second, third or subsequent preferences).

[S 80 of the EAC (EP) (LC) Reg.]

Ballot papers from (a) to (i) will be regarded as invalid on the spot. They will not be counted and need not be treated as questionable ballot papers. A

candidate, an election agent or a counting agent is not entitled to make representations to the RO concerning these ballot papers. [S 80 of the EAC (EP) (LC) Reg.]

Questionable Ballot Papers

5.67 Other ballot papers with doubtful validity are set aside as questionable ballot papers. A questionable ballot paper will be decided as invalid if in the opinion of the RO:

- (a) it has any writing or mark by which the elector or AR can possibly be identified;
- (b) the elector's or AR's intention is unclear (eg for an FC, the vote is not marked by affixing the chop to give a single "✓" in the circle opposite the name of the candidate of the elector's or AR's choice on the ballot paper, and for a SFC, the Arabic numeral is not entered in the circle opposite the name of the candidate of the elector's or AR's choice on the ballot papers. However, the RO may count that ballot paper if he is satisfied that the elector's or AR's intention is clear);
- (c) it is substantially mutilated; and
- (d) it appears to be void for uncertainty.

[S 80 of the EAC (EP) (LC) Reg.]

5.68 For a SFC, where an elector marks on his ballot paper the same preference other than the first preference for two or more candidates, only the preference vote or votes prior in sequence to that preference shall be valid.

Where an elector marks on his ballot paper preferences which are not in a consecutive sequence, only the preference vote or votes which appear before the break in sequence shall be valid.

5.69 The validity of all questionable ballot papers shall be decided by the RO of the relevant constituency. Before the RO makes his decision, a candidate or his election agent or counting agent, if present at the counting zone, may inspect and make representations to the RO on the questionable ballot papers, in the presence of other candidates or their election or counting agents who are present. After considering the representation, if any, the RO should decide on the validity of the questionable paper. If he rejects the ballot paper, he must enclose the word “rejected” on the front of the ballot paper. A candidate or his election agent or counting agent may object to the admission or rejection of a questionable ballot paper by making his objection known to the RO. [S 81 of the EAC (EP) (LC) Reg.]

5.70 If a candidate or his election agent or counting agent object to the rejection of a ballot paper by the RO, the RO shall add to the endorsement the words “rejection objected to”. Questionable ballot papers which are accepted by the RO but objected to by a candidate or his election agent or counting agent will be marked “acceptance objected to”. [S 81 of the EAC (EP) (LC) Reg.] The decision of the RO in regard to any question arising in respect of any ballot paper shall be **final** [s 82 of the EAC (EP) (LC) Reg], and may only be questioned by an election petition [s 61 of the LCO] [see Part II of Chapter 6].

5.71 The counting of the votes will proceed continuously, as far as possible, until the counting is completed.

5.72 When vote counting is completed for the relevant constituency of the FC/SFC, the relevant RO will inform the candidates and their election or counting agents present of the counting result. Any such candidate or his

election agent may request the RO to re-count the votes and the RO shall comply with the request unless in his opinion it is unreasonably made. Where there is no request for a re-count or where the request for a re-count is rejected or the re-count is completed and there is no request for a further re-count or the request for a further re-count has been rejected by the RO, the RO will inform the candidates and their agents of the counting results. [S 79 of the EAC (EP) (LC) Reg.]

PART VIII : DECLARATION OF RESULT

(a) For GCs

5.73 The PRO of each of the counting stations shall report to an ARO for the constituency the final counting or re-count result of his counting station. After tallying the total of the final counting or re-count results with all the final counting or re-count results reported from individual counting stations for the constituency, the RO shall apply the list system of proportional representation and accordingly declare the successful candidates as elected. [S 83 of the EAC (EP) (LC) Reg.]

5.74 In the event that 2 or more lists have the equal largest number of remaining votes and the number of those lists exceeds the number of vacancies to be filled, the RO shall determine the result of the election by drawing lots at the central counting station. He shall use the means of contact of such candidates provided in their nomination papers to request them to be present at the central counting station for conducting the drawing of lots and such list of candidates shall comply as soon as possible. If the RO fails to contact such a list of candidates, the RO may draw lots on behalf of the list of candidates. He shall declare the candidate on whose list the lot falls as elected. He shall

display a notice of the result of the election at a prominent place outside the central counting station and shall also publish the notice in the Gazette within 10 days of the declaration of the result.

(b) For FCs/SFCs

5.75 When the counting of votes and re-counts, if any, are completed and a result obtained, the RO for the relevant constituency shall declare the successful candidate(s) elected for the constituency concerned. In respect of the 24 ordinary FCs, in the event that a vacancy is still to be filled for a constituency and the most successful candidates have an equal number of votes, the RO will determine the result of the election by drawing lots at the central counting station. For the SFC, if the remaining candidates after the final stage of counting have an equal number of votes, the RO will determine the result of the election by drawing lots at the central counting station. He shall declare the candidate on which the lot falls as elected. The RO for the relevant constituency shall display a notice of result of the election of the constituency in a prominent place outside the central counting station. The result of the election will also be published in the Gazette within 10 days of the declaration of the result. [S 83 of the EAC (EP) (LC) Reg.]

PART IX : DISPOSAL OF DOCUMENTS

5.76 As soon as practicable after the PRO has ascertained the result of the poll in an election, he will seal all the relevant documents and ballot papers into packets. Candidates and their agents may observe the packaging, if they wish. [S 85 of the EAC (EP) (LC) Reg.]

5.77 These sealed packets of documents will be sent to the RO by the PRO. The RO will deposit these sealed packets together with the nomination forms, notices of appointment of agents, etc with the CEO for safe custody for six months before they are destroyed. [S 86 of the EAC (EP) (LC) Reg.]

5.78 **Except pursuant to a court order** in relation to an election petition or a criminal proceeding, **no person may inspect any ballot paper in the custody of the CEO** [s 87 of the EAC (EP) (LC) Reg].

CHAPTER 6

ELECTION PETITIONS

PART I : GROUNDS FOR LODGING AN ELECTION PETITION

6.1 The result of the LegCo election may be questioned only by an election petition made on the following grounds:

- (a) the ground that the person declared as elected by the RO under EACO was not duly elected because:
 - (i) he was not eligible to be, or was disqualified from being, a candidate at the election;
 - (ii) he engaged in corrupt or illegal conduct at the election;
 - (iii) corrupt or illegal conduct was generally prevalent at the election; or
 - (iv) material irregularity occurred in relation to the election, the poll or the count; or
- (b) a ground specified in any other enactment that enables an election to be questioned.

[S 61 of the LCO.]

PART II : WHO COULD, AND WHEN TO, LODGE ELECTION PETITIONS

6.2 An election petition may be lodged:

- (a) by 10 or more electors entitled to vote in the relevant constituency; or
- (b) by a person claiming to have been a candidate in the relevant constituency.

[S 62 of the LCO.]

6.3 An election petition questioning an election may be lodged with the Court of First Instance only during the period of 2 months following the date on which the RO has published the result of the election in the Gazette. An election petition is triable in open court and before one judge. At the end of the trial of an election petition, the Court must determine questions of the validity of a nomination or an election, as appropriate. The Court must certify the determination in writing. The determination as certified is final as to the matters at issue concerning the election petition. [Ss 65 and 67 of the LCO.]

CHAPTER 7

APPOINTMENT AND ROLES OF ELECTION AGENT, ELECTION EXPENSE AGENTS, POLLING AGENTS AND COUNTING AGENTS

PART I : GENERAL

7.1 This chapter deals with the appointment of agents at an election and their roles.

7.2 The law and guidelines referred to in this chapter apply to candidates or a list of candidates in a GC election as they apply to a candidate of any other kind of constituency. Wherever there are special features applicable to a **GC list**, they will be expressed in the relevant context.

7.3 A candidate should think carefully before selecting any of his agents. He should choose persons suitable for the task. They will be viewed as his representatives and their conduct may affect the public's perception of him and his election.

PART II : TYPES AND NUMBERS OF AGENTS

7.4 If he so wishes, a candidate or a GC list may appoint the following agents to assist him/it in an election:

- (a) **1** election agent [s 23(1), (2) and (3) of the EAC (EP) (LC) Reg];

- (b) **any number** of election expense agents;
- (c) not more than **2** polling agents for **each polling station** in respect of the GC, the ordinary FC [FCs specified in s 20(1)(e) to (zb) of the LCO] or SFC [FCs specified in s 20(1)(a) to (d) of the LCO] for which he is nominated [s 42(3), (4) and (5) of the EAC (EP) (LC) Reg]; and
- (d) not more than such number of counting agents as will be specified by the EAC [s 66(2) of the EAC (EP) (LC) Reg].

PART III : QUALIFICATIONS OF AGENTS

7.5 The election, polling and counting agents should be holders of Hong Kong identity card and have attained the age of 18 years [ss 23(5), 42(7) and 66(4) of the EAC (EP) (LC) Reg] while an election expense agent needs to be a person who has attained the age of 18 years [s 25(5) of the EAC (EP) (LC) Reg].

PART IV : CIVIL SERVANTS ACTING AS AGENTS

7.6 Civil servants, other than Directorate Officers, Administrative Officers, Police Officers and Information Officers and those officers acting in the above grades and ranks with a view to substantive appointment thereto, may act as agents or assist in electioneering activities provided that they are not already appointed by the CEO as polling or counting staff, and that there is no conflict of interest with their official duties, that no use of public resources is

involved, and that no government uniform is worn. However, to avoid any unfairness or semblance of unfairness or conflict of interest, civil servants who work in a constituency or have extensive contacts with the public in a constituency are well advised not to accept appointment by a candidate in the constituency to be his agent. Civil servants who are allowed to participate in electioneering activities, including the seeking of election donations, for any candidates should not use or be seen to use any public resources in such activities.

PART V : ELECTION AGENT

Appointment

7.7 A candidate (or a GC list) may appoint **1** election agent to assist him and to act on his behalf in an election [s 23(1), (2) and (3) of the EAC (EP) (LC) Reg]. The appointment may be made at any time after a candidate hands in his own nomination form.

7.8 The candidate must give notice of such appointment to the RO for the relevant FC/SFC or GC for which the candidate is nominated [s 23(6) of the EAC (EP) (LC) Reg]. The notice must be in the specified form and signed by both the candidate and the agent (in the case of a GC list, the notice must be signed by all the candidates on the list and be given to the RO by any one of the candidates on the list) [s 23(9) of the EAC (EP) (LC) Reg]. The appointment will not be effective until the notice of appointment is received by the RO [s 23(7) of the EAC (EP) (LC) Reg].

7.9 However, before the notice of appointment is received, the acts of the election agent purported to be appointed by the candidate and the expenses

incurred by any purported agent for promoting the election of the candidate or for prejudicing the election of another candidate or other candidates may be treated as the candidate's own acts and election expenses. It is **important** to note that it is an **illegal conduct** for any person other than a candidate or a candidate's election expense agent to **incur such expenditure** [s 23 of the ECICO].

Revocation

7.10 The appointment of an election agent may be revoked by the candidate at any time. The candidate must also give notice of the revocation in writing to the RO. In the case of a GC list, a notice of revocation must be signed by all the candidates on the list and be given to the RO by any one of the candidates on the list. A revocation of an appointment of an election agent will not be effective until such notice is received by the RO. [S 23(11), (12) and (13) of the EAC (EP) (LC) Reg.]

7.11 If an election agent passes away or has his appointment revoked, the candidate may appoint another election agent. In such a case, the candidate must give notice of the replacement appointment in the specified form to the RO in accordance with para. 7.8 above. In the case of a GC list, all the candidates on the list may jointly appoint a replacement [s 23(14), (15) and (16) of the EAC (EP) (LC) Reg].

Notification

7.12 Not later than 10 days after the expiration of the nomination period, and thereafter as required, each validly nominated candidate/GC list or his/its election agent will receive from the RO a notice containing the details of all the election agents appointed by all candidates for the constituency concerned. In the case of a GC list, the RO can serve the notice to any one of

the candidates on the list or the election agent of the list [s 24(1), (2), (4), (5) and (6) of the EAC (EP) (LC) Reg]. The RO must also display outside his office a notice of the particulars of the election agents [s 24(7) of the EAC (EP) (LC) Reg.]

Role of an Election Agent

7.13 A duly appointed election agent ranks in a **most important position** amongst all kinds of agents of a candidate. He has the **authority to do everything a candidate is authorised to do** for the purposes of the election except:

- (a) anything a candidate is required to do in relation to his nomination;
- (b) to withdraw the candidate's candidature;
- (c) to incur election expenses save where he has been so authorised by the candidate; and
- (d) to authorise a person as an election expense agent to incur election expenses.

[S 23(17) and (18) of the EAC (EP) (LC) Reg.]

IMPORTANT :

An election agent is, along with the candidate, responsible for the management of the campaign. A candidate is responsible for all the acts of his or his list's election agent. If the election agent fails in his duties, he may contravene the law, and in particular,

the ECICO, and may commit criminal offences for which the candidate may also be liable, with serious consequences. An election agent will need to be authorised by a candidate to incur election expenses. If so authorised, the election agent becomes also an election expense agent. [See Part VI of this chapter.]

7.14 Candidates and their election agents are entitled to be present at the counting of the votes and are normally allowed admission to all polling stations in respect of the constituency concerned. However, the PRO of a polling station may regulate the number of candidates and their agents to be admitted to the polling station at any one time, for the purpose of maintaining order in the polling station and ensuring that polling is conducted smoothly. **Whilst inside a polling station or a counting station, the provisions to be observed by polling agents and counting agents are also applicable to candidates and their election agents.** They are therefore advised to familiarise themselves also with the guidelines set out in Parts VII and VIII of this chapter.

PART VI : ELECTION EXPENSE AGENTS

Authorisation

7.15 A candidate may authorise any number of election expense agents to incur election expenses on his behalf in an election. All the candidates on a GC list must jointly authorise the election expense agent to incur election expenses on behalf of the list, for any expenditure incurred for promoting the election of any candidate on the GC list or for prejudicing the election of another candidate or list of candidates must necessarily be incurred for the promotion or benefit of all candidates on the whole list. Each

candidate on the GC list must authorise the other fellow candidate(s) on the same GC list as his election expense agent(s), or otherwise none of the other fellow candidates can lawfully incur election expenses for him, or for the whole list which includes him [s 23 of the ECICO]. For details of the special features applicable to the GC list, see Part VII of Chapter 16.

7.16 The authorisation shall be in writing on a specified form and state the name, identity document number and residential address of the election expense agent, and must specify the maximum amount of election expenses the agent may incur [s 25(6) and (7) of the EAC (EP) (LC) Reg]. It should be signed by both the candidate and the agent (in the case of a GC list, the authorisation must be signed by all the candidates on the list) [s 25(8) of the EAC (EP) (LC) Reg]. A copy of any authorisation must be lodged with the RO for the constituency, or the CEO if the RO has not been appointed, by the candidate [s 25(9) of the EAC (EP) (LC) Reg].

7.17 The authorisation is not effective until it has been received by the RO or the CEO as the case may be [s 25(11) of the EAC (EP) (LC) Reg]. Before the authorisation is received, no election expense should be incurred by a person purported to be authorised in the authorisation as an election expense agent. It is also important to note that it is an illegal conduct for any person other than a candidate or a candidate's election expense agent to incur such expenses [s 23 of the ECICO]. The expenses so incurred may also be counted as the candidate's election expenses.

Revocation

7.18 The authorisation of an election expense agent may be revoked by a candidate at any time. The candidate must give notice of the revocation as soon as possible in writing to the RO, or the CEO if the RO has not been appointed. In the case of a GC list, the notice must be signed by all the

candidates on the list and be given by any one of the candidates on the list. [S 25(14) and (15) of the EAC (EP) (LC) Reg]. The RO or the CEO, as the case may be, will only regard a revocation as effective when he receives the notice [s 25(16) of the EAC (EP) (LC) Reg]. The election expenses already incurred will still be counted as election expenses of the candidate/list of candidates.

Role of Election Expense Agents

7.19 An election expense agent is authorised to incur election expenses on behalf of a candidate. He must not incur election expenses in excess of the amount specified in the form of authorisation; otherwise he commits a criminal offence [s 23(4) of the ECICO].

Candidate's Duty to know the Details of Election Expenses incurred by his Election Expense Agents

7.20 Every candidate is under a **duty**, subject to criminal penalty for breach, to submit to the CEO a return and declaration of his election expenses and donations with supporting vouchers not later than 60 days after the publication in the Gazette of the result of an election [s 37 of the ECICO and see Part IV of Chapter 16]. For the efficient and effective discharge of his duty, the candidate should **make sure** that his election expense agents will keep account of all election expenses incurred on his behalf and will provide to him, as soon as practicable but not later than the same 60 days period, a detailed statement of expenditure in which each item of expenditure of \$100 or above has to be supported by an invoice and a receipt. If any item of expenditure incurred by the election expense agents is paid or defrayed or contributed to by a donation, the candidate should **make sure** that they will provide him with a statement stating the expenses. If an item is not explicit in monetary terms, it should be assessed at a reasonable value; and if any item is more than \$1,000, it

should be supported by a copy of the receipt issued to a donor (in a specified form signed by the donor). Without such statements and vouchers provided by the election expense agents, the candidate will no doubt have difficulty in discharging his duty to file the return and declaration of election expenses and donations, which **may render him liable for a criminal offence** under s 38 of the ECICO. A candidate and his election expense agents should familiarise themselves with Part VI of Chapter 16 if he is eligible to apply for financial assistance to partly offset his election expenses.

Public Inspection of Authorisation

7.21 The RO or the CEO, as the case may be, will make available for public inspection all copies of authorisations submitted by candidates until the expiration of the period for which copies of the election return lodged by the candidates are available for inspection, ie up to the first anniversary of the date on which the result of the election is published [s 41 of the ECICO]. This offers the public and other candidates an opportunity to scrutinise the amount of election expenses [s 26 of the EAC (EP) (LC) Reg].

PART VII : POLLING AGENTS

Appointment

7.22 A candidate (or a GC list) may appoint **not more than 2 polling agents** for each polling station in respect of the constituency for which he is nominated [s 42(3), (4) and (5) of the EAC (EP) (LC) Reg].

7.23 The appointment should be made on a specified form. The candidate must give notice of such appointment in writing signed by him to the

CEO at least **one week** before the date of election [s 42(8) and (11) of the EAC (EP) (LC) Reg]. In the case of a GC list, the notice must be signed by all the candidates on the list and be given to the CEO by any one of the candidates on the list [s 42(11) of the EAC (EP) (LC) Reg]. Where a candidate appoints a polling agent after the above deadline, he is required to give notice of the appointment to the PRO of the polling station for which that agent has been appointed. Such notice must be given by the candidate (or in the case of a GC list, any one of the candidates on the list) or the election agent **personally** by delivering the notice of appointment to the PRO at the relevant polling station on polling day and before the agent concerned enters the polling station [s 42(9) of the EAC (EP) (LC) Reg]. The appointment will not be effective until the notice of appointment is received by the CEO or the PRO, as the case may be [s 42(10) of the EAC (EP) (LC) Reg].

Revocation

7.24 The appointment of a polling agent may be revoked by the candidate at any time. The candidate (or in the case of a GC list, any one of the candidates on the list) must also give notice of revocation in writing and in the specified form, to the CEO before polling day or to the PRO on polling day in the manner specified in the preceding paragraph [s 42(13) and (14) of the EAC (EP) (LC) Reg]. In the case of a GC list, a notice of revocation must be signed by all the candidates on the list [s 42(13) of the EAC (EP) (LC) Reg]. A revocation of an appointment of a polling agent will not be effective until notice thereof is received by the CEO or the PRO, as the case may be [s 42(15) of the EAC (EP) (LC) Reg].

Role of Polling Agents

7.25 Polling agents are appointed **to assist a candidate in observing the conduct of the poll** to detect impersonation or irregularity at polling stations.

Provisions which the Polling Agents should be aware of

7.26 Although 2 polling agents may be appointed by a candidate for each polling station, only 1 polling agent per candidate may be admitted at any one time to the polling station for which he has been appointed [s 44(6) of the EAC (EP) (LC) Reg]. He is required to stay and keep his movements within and not outside the area designated for observation of the poll. Where a candidate or his election agent is present within a polling station, a polling agent of that candidate will not be allowed to be present at the same time within the polling station [s 44(7) of the EAC (EP) (LC) Reg].

NOTE :

The PRO of a polling station may regulate the number of candidates, election agents and polling agents to be admitted to the polling station at any one time, for the purpose of maintaining order in the polling station and ensuring that polling is conducted smoothly. A notice will be displayed outside each polling station to inform all concerned about the capacity of the area designated inside the polling station for candidates and their agents to observe the poll. Admission will be on a first-come-first-served basis. In order that as many candidates, election agents and polling agents as possible will have a chance to attend at the polling station to observe the conduct of the poll, any candidate, election agent or polling agent who has been

admitted to the polling station will only be allowed to stay in there for one hour. Thereafter he must leave the polling station unless the designated area is not yet full and no other candidate, election agent or polling agent is waiting to be admitted. The fact that a candidate, election agent or polling agent has left after attending at a polling station will not preclude him from being admitted to the polling station again, on a first-come-first-served basis and subject to the capacity of the designated area not being exceeded. Everyone admitted is required to sign in with the time of entry written down by him. Each person queuing outside the polling station will be issued with a number chit to record the order of his application to get into the designated area; and when the turn of his number is reached, the number will be called, but if he is not there at that time, he will be automatically discounted from the queue and he will have to get another number chit when he returns. The bearer of the chit with a number next after the absentee's number will be allowed to get in instead.

7.27 Before entering a polling station, every person, other than an elector/AR or a police officer on duty or a member of the Civil Aid Service on duty, must make a Declaration of Secrecy on a specified form and observe the provisions governing the secrecy of voting [s 95 of the EAC (EP) (LC) Reg]. This is to make sure that, subject to penalty of making a false declaration, all persons inside a polling station will observe the secrecy of the vote of the elector and, in particular, not to divulge which elector/AR has voted for which candidate or GC list.

7.28 On attending the polling station for which he has been appointed, a polling agent shall report to the PRO and produce his identity card and the

Declaration of Secrecy completed by him for inspection [s 44(10) of the EAC (EP) (LC) Reg].

7.29 The following will occur before, during and after the poll on the polling day:

(a) Before

- (i) Before the commencement of the polling, the PRO will inform the candidates or their agents (either election agent or polling agent) if they are present, the number of ballot papers in his (the PRO's) possession, showing them the books of ballot papers not yet issued to any elector (“**UNISSUED** ballot papers”).
- (ii) The PRO will show such persons the empty ballot boxes before proceeding to lock and seal them.

(b) During

- (i) In the course of polling, the PRO will show to each candidate or his election or polling agent, who is present at the relevant time, any abandoned ballot papers that have been issued or any torn pieces of such ballot papers found lying anywhere in the polling station (“**UNUSED** ballot papers”). Such ballot paper will not be put into a ballot box and will not be counted at the counting of votes. [Ss 61 and 80 of the EAC (EP) (LC) Reg].
- (ii) Where a person, representing himself to be a particular elector/AR entered on the register, applies for any ballot

paper after a person has been issued with any ballot paper as such an elector/AR, he may be issued with a ballot paper with the word “**TENDERED**” endorsed on the front. Such ballot paper will not be counted at the counting of votes. [Ss 60 and 80 of the EAC (EP) (LC) Reg.]

- (iii) Any elector/AR who has inadvertently torn or damaged any ballot paper or has made an error in marking any ballot paper issued to him may ask the PRO to exchange it for another ballot paper. Such spoiled ballot paper will be endorsed on the front with the word “**SPOILT**” and will be kept by the PRO. The spoiled ballot papers will not be counted at the counting of votes. [Ss 62 and 80 of the EAC (EP) (LC) Reg.]

(c) After

- (i) The PRO will, in the presence of persons present, lock the flap on the lid of the ballot boxes and seal it. He will also inform each candidate or his agent who is present of the number of the following types of ballot papers in his possession: unissued ballot papers, unused ballot papers, and spoiled ballot papers.
- (ii) For GCs, candidates and their counting agents, if present, may stay inside the polling station to observe the conversion of the venue into a counting station and then the count that will commence upon the completion of the conversion.

- (iii) For FCs/SFCs, up to 2 persons being candidates competing in the FCs/SFCs (or their respective agents), if they so wish, will be allowed to accompany the PRO in the delivery of the ballot boxes from the polling station to the central counting station under police escort. Where there are more than 2 such persons remaining at the polling station, the PRO will draw lots to determine which 2 candidates or their respective agents will participate in the delivery. Other FC/SFC candidates and their agents are allowed to remain in the polling station only until they see that the police escort for the delivery is available. Thereafter, all of them, except those 2 persons who are to participate in the delivery, must leave the polling station.

7.30 Generally speaking, a polling agent may observe all proceedings in the polling station and record his observations but shall not do anything that may interfere with the conduct of the poll. A polling agent **MAY**:

- (a) leave the polling station at any time during the poll in which case his place may be taken by a candidate, an election agent or another polling agent appointed to attend at the polling station [see para. 7.26];
- (b) observe the locking and sealing of empty ballot boxes before the poll commences and the locking and sealing of the ballot boxes at the close of the poll;

NOTE :

A polling agent who signs the sealing certificate of a ballot box as witness is required to write his name in block letters beneath his

signature for easy identification. Candidates are advised to keep a list of their own polling agents to facilitate checking when the sealing certificate is broken at the counting station.

- (c) observe the issue of ballot papers to electors and ARs and the crossing out of the relevant entries from the copy of the register of electors, subject to the condition that they cannot interfere with the work of the polling staff;
- (d) where there is reasonable ground for questioning the bona fides of an elector/AR, ask the PRO to put the following prescribed questions (subject to necessary modifications) to that person at the time of his application for a ballot paper (but not afterwards):
 - (i) Are you the person registered in the final register now in effect for this GC and/or FC/SFC (as appropriate), as follows (reads the whole of the relevant entry in the register)?
 - (ii) Have you already voted for this or any other GC and/or FC/SFC (as appropriate) in this election?

NOTE :

The person will not be issued with any ballot paper unless he has answered the questions to the satisfaction of the PRO. [S 51(3) and (4) of the EAC (EP) (LC) Reg.]

- (e) where there is reasonable cause to believe that a person who has applied for a ballot paper has engaged in impersonation, declare it to the PRO for appropriate action before that person leaves the

polling station. This may possibly lead to the arrest of the person. The polling agent must however undertake in writing to substantiate the charge in a court of law. [S 52 of the EAC (EP) (LC) Reg.]

7.31 Inside a polling station, a polling agent **MUST NOT**:

- (a) interfere with or attempt to influence any elector/AR;
- (b) speak to or communicate with any elector/AR if the RO, the ARO, the PRO, the Deputy PRO and any Assistant PRO has given direction to him not to do so, or interfere with or attempt to interfere with any ballot boxes, ballot papers, the marked copy of the register or other relevant election materials. In this regard, a polling agent should station within the designated area demarcated by red adhesive tape, and must not enter, or move close to, the restricted zone delineated with yellow tapes about 1 metre around the voting compartments. Moreover, it is most improper for a polling agent to ask an elector/AR about his identity card number, let alone check an elector/AR's identity card;
- (c) attempt to obtain information, or disclose any knowledge acquired, concerning the vote of any elector/AR. A polling agent should read and observe carefully the provisions governing the secrecy of voting issued with the form of Declaration of Secrecy;
- (d) exhibit or leave or distribute any campaign material;

- (e) without reasonable excuse, display any propaganda material, eg any badge, emblem, clothing or head-dress, which:
 - (i) may promote or prejudice the election of a candidate or candidates at the election; or
 - (ii) makes direct reference to a body any member of which is standing as a candidate in the election or a prescribed body which has given consent to its registered name or emblem to be printed on any ballot paper; or
- (f) use a mobile telephone or any telephone or paging machine or any other form of electronic communication device if the RO, the ARO, the PRO, the Deputy PRO or any Assistant PRO has given direction to him not to do so.

[S 45 of the EAC (EP) (LC) Reg.]

7.32 A polling agent must not misconduct himself in or in the vicinity of a polling station or fail to obey any lawful order of the RO or the PRO; otherwise he commits an offence punishable with a fine and imprisonment and may be ordered by such officer to leave the area. If he fails to leave immediately, he may be removed by a police officer or by any other person authorised in writing by the RO or the PRO to remove him. The person so removed may not re-enter the polling station during that day except with the permission of the RO or the PRO. [S 46 of the EAC (EP) (LC) Reg.]

Other Useful Information for Polling Agents

7.33 Most of the persons admitted to a polling station will be wearing identifications (eg badges). Candidates, their election agents and polling

agents will be required to wear an identification device issued by the RO or PRO for identification. If in doubt, a polling agent may enquire with the PRO as to the identities of the persons inside the polling station. No attempt, however, should be made to obtain information as to the identity of any elector/AR who is about to vote or has voted. [S 44 of the EAC (EP) (LC) Reg.]

7.34 There may be electors with a disability who have been permitted to vote in the polling station specifically designated for the constituency for the purpose. Candidates or their agents can make inquiries with the RO for information.

7.35 Only the PRO, the Deputy PRO or an Assistant PRO may, in the presence of one of the Polling Officers as a witness, help an elector who claims he is unable to read or write or incapacitated by visual deficiency or other physical cause to mark a ballot paper to indicate the choice of the elector [s 59 of the EAC (EP) (LC) Reg]. The responsible officer should inform the candidates or their agents who are present when such a request for assistance is received. A candidate or his polling agent in the polling station may request the PRO, the Deputy PRO or an Assistant PRO to choose a particular Polling Officer who is not working at the issuing counter as the witness, but the final decision as to which Polling Officer should be the witness remains with the PRO, Deputy PRO or Assistant PRO. An incapacitated elector's relatives, friends and any other persons are in no circumstances allowed to accompany the elector in the course of voting.

7.36 In each polling station designated for an election in respect of a GC or an FC, a number of **templates** are made available for the use of the visually impaired elector, if he chooses, to facilitate him to mark his vote on the ballot paper [s 59(3) of the EAC (EP) (LC) Reg]. The template contains the following features:

- (a) the template for each constituency is of the same width and length as the ballot paper;
- (b) the template contains embossed numbers or numbers in braille starting with the first numeral (or code + numeral) in a sequence assigned to the candidates or list of candidates of the constituency on the top followed downwards by other numerals in that sequence, and on the right hand side against each of the number is a round hole;
- (c) the **left hand top corner** of the ballot paper and the template is cut so as to enable the elector to place the template on top of the face of the ballot paper in the proper direction; and
- (d) when the template is placed properly over the ballot paper, each embossed or brailled number corresponds with the candidate number or the GC list number in the constituency; and each of the holes on the template corresponds with the circle on the ballot paper against the candidate/list number. The number of candidates/lists in the constituency equals the number of holes under which there is ballot paper.

In the case of an election in respect of a GC or an ordinary FC which adopts the “list system of proportional representation” or “first past the post voting system”, the visually impaired elector should apply the chop (with a “✓” sign) provided on the circle through the hole on the template against the candidate/list number(s). In the case of an election for one of the 4 SFCs which adopts the “preferential elimination system”, the visually impaired elector should mark numbers starting from 1 on the ballot paper through the hole against the candidate numbers of his choice, in descending order of preference. Whenever it is necessary, the polling staff will help the visually

impaired elector to identify the different ballot papers before the elector proceeds to mark his vote.

7.37 No person may canvass or display any election propaganda material relating to any candidates/GC lists or the election within a polling station. Candidates and their agents should not bring electioneering literature into the polling station or leave them there and should remove any promotional badges and emblems before entering. A person must not use a sound amplifying system or device for any purpose within the NCZ; nor should he use such system or device or conduct any activities (eg lion dance), for canvassing, so that the sound emitted by it can be heard in the NCZ. Also a person must not stay or loiter in the NSZ without the express permission of the PRO. Any person who undertakes photographing, filming and video or audio recording within a polling station without the express permission of the PRO, or the RO for the constituency, or a member of the EAC, commits an offence [s 45(2) of the EAC (EP) (LC) Reg]. Normally such permission is only granted to members of the media or government photographers for publicity purposes. Polling agents should also read Parts I-VI of Chapter 5 on all matters relating to polling and in particular, paras. 5.38 and 5.39 for activities that are prohibited, and the consequences of doing such activities, in a polling station.

7.38 If a candidate or his election or polling agent has any complaint about whatever happens inside a polling station, he should follow the procedures laid down in para. 20.9 of Chapter 20.

PART VIII : COUNTING AGENTS

Appointment

7.39 A candidate (or a GC list) may appoint not more than such number of counting agents as will be specified by the EAC to attend at the count [s 66(1) and (2) of the EAC (EP) (LC) Reg]. The same persons may, but need not, be appointed also as polling agents.

7.40 The appointment should be made on a specified form. In the case of a GC list, the appointment must be made jointly by all the candidates on the list [s 66(7) of the EAC (EP) (LC) Reg]. The candidate (or in the case of a GC list, any one of the candidates on the list) must give notice of such appointment in writing to the RO at least **one week** before the date of election [s 66(5) of the EAC (EP) (LC) Reg]. Where a candidate appoints a counting agent after the above deadline, the notice of the appointment must be given by the candidate (or in the case of a GC list, any one of the candidates on the list) or the election agent **personally** by delivering the notice of appointment to the PRO (or the RO in the central counting station) during the period from the commencement of the poll to the conclusion of the count, but before the agent concerned enters the counting station [s 66(6) of the EAC (EP) (LC) Reg]. The appointment will not be effective until the notice of appointment is received by the RO or the PRO, as the case may be [s 66(8) of the EAC (EP) (LC) Reg].

Revocation

7.41 The appointment of a counting agent may be revoked by the candidate (or in the case of a GC list, all the candidates on the list) at any time.

The candidate (or in the case of a GC list, any one of the candidates on the list) must also give notice of revocation in writing and in the specified form to the RO [s 66(9) and (10) of the EAC (EP) (LC) Reg]. Any such notice given after the commencement of the poll shall be given by the candidate (or in the case of a GC list, any one of the candidates on the list) or his election agent **personally** by delivering the notice to the PRO (or the RO in the central counting station) [s 66(11) of the EAC (EP) (LC) Reg]. A revocation of an appointment of a counting agent will not be effective until notice thereof is received by the RO or the PRO, as the case may be [s 66(12) of the EAC (EP) (LC) Reg].

Role of Counting Agents

7.42 Counting agents are appointed to attend at the counting station **to observe the breaking of the seals on the ballot boxes, the sorting, separation and counting of ballot papers and the counting of votes recorded on the valid ballot papers.** This arrangement ensures the transparency of the counting process and is conducive to openness and fairness.

Provisions which the Counting Agents should be aware of

7.43 Before the counting commences, every person authorised to be present at a counting station, other than the police officers and members of the Civil Aid Service on duty, must make a Declaration of Secrecy on a specified form and observe the provisions governing the secrecy of voting [s 95 of the EAC (EP) (LC) Reg]. This is to make sure that, subject to penalty of making a false declaration, all persons inside a counting station will observe the secrecy of the vote of the elector and, in particular, not to divulge which elector has voted for which candidate or GC list. Members of the public present within the area designated by the PRO will not be required to make a Declaration of Secrecy.

7.44 On attending the counting station, a counting agent shall report to the relevant PRO in the case of a GC, and the relevant RO in the case of an FC/SFC and produce his identity card and the Declaration of Secrecy completed by him for inspection [s 68(4) of the EAC (EP) (LC) Reg].

7.45 Generally speaking, counting agents are entitled to be present throughout the count to observe the relevant counting proceedings. They will be allowed by the PRO or the RO to stay close to, and round the counting tables to monitor the count. Nonetheless, they must not handle any ballot papers. A counting agent **MAY**:

- (a) observe the opening of the ballot boxes for the relevant constituency by the PRO, RO or AROs;
- (b) inspect any papers other than ballot papers taken from the ballot boxes before they are disposed of;
- (c) observe the conduct of the count by Counting Officers including how ballot papers relating to a constituency are separated from those relating to other constituencies and how individual votes are counted; and
- (d) observe, where he wishes, the packing of ballot papers by the Counting Officers and PRO or the RO, as the case may be, at the conclusion of the count.

7.46 A counting agent **MUST NOT**:

- (a) handle, separate or arrange ballot papers; and

- (b) misconduct himself in or in the vicinity of a counting station or fail to obey any lawful order of the PRO or the RO, as the case may be, otherwise he commits an offence punishable with a fine and imprisonment and may be ordered by the PRO or the RO to leave the area. If he fails to leave immediately, he may be removed by a police officer or by any other person authorised in writing by the PRO or the RO to remove him. The person so removed may not re-enter the counting station except with the permission of the PRO or the RO, as the case may be. [S 69 of the EAC (EP) (LC) Reg]

7.47 Counting agents should read Part VII of Chapter 5 on all matters relating to counting and in particular, paras. 5.49 and 5.52 for activities that are prohibited and the consequences of doing such activities, within the counting station.

CHAPTER 8

ELECTION ADVERTISEMENTS

PART I : WHAT CONSTITUTES AN ELECTION ADVERTISEMENT

8.1 EA, in relation to the LegCo election, means:

- (a) a publicly exhibited notice; or
- (b) a notice delivered by hand or electronic transmission; or
- (c) a public announcement made by radio or television or by video or cinematographic film; or
- (d) any other form of publication,

published for the purpose of promoting or prejudicing the election of a candidate or candidates at the election.

IMPORTANT :

“Candidate” includes a person who has publicly declared an intention to stand for an election at any time before the close of nominations for the election, whether or not he has submitted a nomination form [s 2 of the ECICO]. The reference of “candidate” in this chapter includes a GC list to which the list voting system of proportional representation applies.

8.2 EA includes the following if they are published for the purpose of promoting or prejudicing the election of any candidate or candidates in an election:

- (a) any address, notice, bill, placard, poster, board, banner, flag, standard, colour, sign, message, sound, image or picture and any article, thing or material;
- (b) audio/video cassette tapes, discs, diskettes, electronic messages, websites (except those discussion forums on websites), facsimile transmissions, balloons, caps, badges, emblems, carrier bags, head-dress and clothing; or
- (c) any thing or material published by any person or any organisation, including political organisation, professional or trade organisation, owners corporation, mutual aid committee, tenants association, owners committee, etc (irrespective of whether or not the candidate concerned is an office bearer or member) showing his or its support for any candidate or GC list or advertising the platform or services of such an organisation with reference to a candidate or GC list by name or photograph or in any other form or manner.

8.3 EA also includes:

- (a) publicity materials containing the name or photograph of a candidate or GC list issued or displayed during the election period (ie the period beginning with the nomination day for the election and ending with the polling day for the election) even though the content of the publicity material is not, on the face of it, election related. Examples include surveys, questionnaires,

posters publicising functions like vegetarian meal, tours, courses, offer of free legal or medical or other professional service, etc; and

(b) any performance report published or distributed **during** the election period by:

(i) a serving member of the LegCo; or

(ii) a serving member of the DC; or

(iii) a serving member of the Heung Yee Kuk; or

(iv) a serving chairman or vice-chairman or member of the Executive Committee of a Rural Committee; or

(v) a serving village representative (“VR”),

who is running as a candidate for the LegCo election. These persons are termed “incumbent candidates” under the ECICO. A performance report means a document giving details of activities organised, services rendered or work done by such an incumbent candidate. [S 33 of the ECICO.]

8.4 For the avoidance of doubt, a performance report distributed **before** the election period will also be regarded as an EA **if it is published for the purpose of promoting or prejudicing the election of a candidate or candidates at the election.** It is important to note that a performance report referred to in this paragraph and para 8.3(b) above must comply with all the requirements for an EA.

8.5 If the incumbent members distribute performance reports before they submit their nomination forms or publicly declare their intention to stand as candidates, they are not candidates at the time when their performance reports are being distributed. On such basis, the expenditure incurred in the distribution of such reports before the submission of nomination or public declaration of their intention to stand as candidates would not be counted as his election expenses.

8.6 A candidate in an election may put up and display EAs in accordance with these guidelines which summarise the relevant law and regulations.

Election Advertisements Prejudicing the Election of a Candidate

8.7 There are occasions that candidates or a third party may publish EAs for the purpose of prejudicing the election of a candidate at the election. The concept of “promoting” and “prejudicing” the election of someone can be relative. To publish a document which is designed to persuade electors not to vote for one candidate would have the effect of improving the chances of success of other candidate(s) and could therefore be said to promote the latter’s election.

- (a) If candidate A criticises candidate B in his own EAs with a view to prejudicing B’s candidature at the election, candidate A has to include the expenditure incurred in his election expenses.
- (b) If a third party criticises candidate B in an EA and that the EA has the effect of indicating support for candidate A, that person must obtain candidate A’s prior consent for incurring the production expenses before he produces that EA. The expenditure incurred will have to be included in candidate A’s election expenses.

- (c) If the third party publishes an EA as described in (b) above without the prior consent of candidate A, he will be breaching s 23 of the ECICO as only a candidate or a person who has been duly authorised by a candidate as his election expense agent may incur election expenses. The EA should be regarded as the EA for candidate A. It would only be fair to candidate A that the third party needs to obtain candidate A's consent before publishing such EA since candidate A is ultimately responsible for his own election expenses. It would also prevent candidate A from circumventing the law by asking the third party to publish materials prejudicing candidate B without having to account for the expenses of those materials.

8.8 Those materials published with a purpose of prejudicing other candidates are not treated as EAs if no reference is made to a particular candidate. However, materials published by a third party, other than the candidates themselves, for the purpose of prejudicing a candidate would be treated as EAs for the candidate receiving the benefit, if reference could be made from the materials to identify the candidate being prejudiced and the candidate to be benefited.

8.9 The **election expenses** allowed by law to be incurred by a candidate include the expenses he incurs for the preparation and publication of EAs, and he should therefore be careful in planning how much he should spend on this score. [For the definition of election expenses, see s 2 of the ECICO.]

8.10 Subject to the maximum amount that can be incurred by a candidate for election expenses [s 24 of the ECICO], there is no restriction as to the quantity of EAs employed by him. The maximum amounts allowed for the elections of GCs and FCs are specified in the Maximum Scale of Election

Expenses (Legislative Council) Order. [See para. 16.8 of Chapter 16.]

8.11 A candidate must ensure the correctness and accuracy of all factual statements in his EAs. [For criminal sanctions, see ss 25, 26 and 27 of the ECICO.]

PART II : PERIOD AND AREA OF DISPLAY

8.12 With the necessary **written permission or authorisation**, a candidate may display EAs on government or private land and property [s 104A of the Public Health and Municipal Services Ordinance (Cap 132) and s 4 of the Land (Miscellaneous Provisions) Ordinance (Cap 28)].

8.13 Display spots are classified into two types:

- (a) **designated spots** which are spots on government land/property and sometimes even at the premises owned or occupied privately that have been made available to the Government for allocation to candidates of the 5 GCs and the 28 FCs; and
- (b) **private spots** which are spots on private land/property in respect of which written permission or authorisation for display has been obtained from the owner or occupier concerned by the candidate himself.

Government or Private Land/Property - Designated Spots

8.14 Designated spots on government land for the use of candidates to display their EAs will be designated by the RO for the GC in which the spots

are situated. Some of the government land and property have been allocated to some public authorities, such as the Housing Authority, and are under their respective control. The RO for the GC (who in most cases will be one of the District Officers of the Districts encompassed by the GC) will designate public spots in coordination with the said authorities and the ROs for the other constituencies. The designated spots will be allocated to candidates by reference to and on the basis of lists, as the list system of proportional representation applies to the GC election. **Each GC list** will be as far as practicable allocated **the same number of designated spots**.

8.15 There may be certain places on government or private land/property where candidates of the 24 ordinary FCs, to which the first past the post voting system applies, may wish to display their EAs, because those places are frequented by members of their electorate. These display spots will be designated by their respective ROs.

8.16 The display spots for the 4 SFCs, which have a relatively small electorate, will also be designated by their respective ROs, taking into account their particular circumstances.

8.17 Prospective candidates as well as political organisations are welcome to suggest locations of display in which they are interested. The ROs concerned will take into consideration such suggestions in drawing up the list of “**designated spots**”, with absolute discretion to decide whether to adopt the suggestions.

NOTE :

Suggestions should reach the CEO **three months before the polling day**.

Other Land/Property - Private Spots

8.18 Candidates who wish to display their EAs on land/property other than government land/property and other than the designated spots must obtain the **prior written permission or authorisation** of the owner or occupier [s 104A of Cap 132]. The obtaining of written permission or authorisation from the private owner or occupier is a matter for private arrangement between the candidate and the owner or occupier, and they are therefore called “**private spots**”. A copy of the written permission or authorisation must be deposited with the RO relevant to the GC or FC before display. [Please also see para. 8.23 below.] Any consideration, fee or money incurred or agreed to be paid by or on behalf of the candidate to the owner or occupier for display of his EAs forms part of his election expenses. If a commercial advertising space for rent is allowed by the private owner or occupier to be used free of charge by a candidate for display of his EAs, a reasonable market value for the use of that space will have to be accounted for by the candidate as an election donation and counted as election expenses. Such a provision is to ensure that the candidate concerned will not have unfair advantage over the others who do not have access to such facilities. If the private spot for displaying the EA is normally used for commercial purpose, the actual rent charged or the usual rent or market rent that would normally be charged should be counted as the election expenses of the candidate concerned, irrespective of whether it is owned by the candidate or whether the owner of it allows the candidate to use it free of charge (in which case it would be a donation of the rent). Where a space provided by a particular private owner or occupier for a candidate to display EAs is not used for commercial advertising, but similar space belonging to other owners or occupiers are available for commercial advertising, the market value of the space should also be accounted for. The provision of this kind of rent-free space should be regarded as donation. For details on how the estimated value should be assessed, please refer to para.

16.21 of Chapter 16. If a space is not normally used by any private owners or occupiers for commercial advertising, there is no need for the candidate to account for its value.

8.19 The EAC appeals to owners and occupiers of private premises to give all candidates and GC lists competing in the same constituency **fair and equal treatment** in the display of EAs. [For details, please see Chapter 10 : Electioneering at the Living or Working Places of Electors, Premises of Organisations to which Electors belong and Buildings which Electors Frequent.]

8.20 Candidates should note that public corporations may have their own rules for display of EAs, eg the Mass Transit Railway Corporation Limited has its own set of rules for such display in residential estates under its management.

General Principle in Allocating Designated Spots

8.21 About two-thirds of the designated spots within a GC will be for allocation to lists of candidates of that GC. The remaining one-third of the designated spots will be for allocation amongst candidates of the 24 ordinary FCs and 4 SFCs.

8.22 The RO for each constituency will allocate the designated spots, as the case may be, to candidates of the constituency either in accordance with the mutual consent of the candidates or by the drawing of lots after the close of nominations, when the number of candidates contesting in the constituency will have been ascertained. **No display of EAs will be allowed on any designated spots before the allocation.** [Also see the requirements in para. 8.28 and Part V below.] A candidate will be provided with a list of the

designated spots allocated to him, together with a set of standardised map or maps to help all concerned to identify the locations.

Written Permission or Authorisation

8.23 The RO will have already obtained prior approval from the relevant authorities under s 104A of Cap 132 and s 4 of Cap 28 for candidates to display their EAs at designated spots. Immediately after the allocation of designated spots is made, a copy of the necessary written permission or authorisation under the relevant legislation will be provided to the candidates by the RO of the constituency concerned [see Part III below]. For any display on private premises, written permission or authorisation of the private owner or occupier will have to be obtained by the candidates themselves. A person displaying an EA without the necessary written permission or authorisation commits an offence punishable by a fine of up to \$10,000 and, where the offence is a continuing offence, by an additional daily penalty of \$300 for each day during which it is proved to the satisfaction of the court that the offence has continued [s 104A of Cap 132]. The fines so incurred will also be treated as election expenses. **A copy of the written permission or authorisation must be deposited by the candidate with the RO before display or distribution** [s 102(10)(a) of the EAC (EP) (LC) Reg].

No-Display Areas

8.24 No EA may be displayed within the boundaries of a polling station (including the outer walls of the premises) or within any NCZ [see Chapter 14: Prohibition Against Canvassing Activities Outside Polling Stations], except for static displays that are authorised by the RO or the PRO of the relevant polling station. Where there are private premises situated within the NCZ, the ROs should issue a notice in advance to all the candidates in the constituencies concerned asking them to remove all of their EAs, if any, posted

up at the private premises within the NCZ which can be seen by electors on their way to the polling stations on the polling day. If the candidates fail to remove the EAs as requested by the ROs, the ROs may issue a warning to them to remove the offending EAs immediately. If the candidate or GC list fails to do so, the EAC may issue a censure or reprimand. The RO for the constituency for which a candidate/GC list stands will provide the candidate/GC list with one set of sketch maps or plans showing the boundaries of all polling stations in respect of the relevant constituency and all NCZs outside those polling stations.

8.25 EAs on display must not distract motorists or interfere with the sight lines of motorists and pedestrians, obscure any traffic sign or traffic light signal, or obstruct the circulation of pedestrians. Thus, there will be no public spots or designated spots on or over flyovers, bridges including footbridges, lamp posts, road signs and railings at corners of road junctions or at or near pedestrian crossings, bus stops and bus termini.

PART III : ALLOCATION OF DESIGNATED SPOTS

8.26 The RO for a constituency will make known to each candidate/GC list of the constituency at the time of receipt of the nomination form the following information:

- (a) The general locations of the designated spots, which may include unleased government land and premises managed by the Housing Department and the Hong Kong Housing Society, and private premises available for allocation to the candidates for a particular FC. The size and number of spots for allocation will be finalised by the RO, taking into account the number of candidates

in the constituency, **after** the close of nominations. In order to allow all contested candidates to display their EAs at all locations, particularly popular ones, the size of each spot may vary from location to location; and

- (b) The date and time for conducting the allocation of designated spots, which would normally be held within three days following the close of nominations. The RO will invite representatives from the relevant authorities relating to government land/property, save those who have already given a blanket approval, to be present to give the necessary written authorisation for the spots allocated.

8.27 The ROs for the FCs will need to know the exact number of candidates in each constituency who wish to display EAs at designated spots within a particular GC area, so that he can finalise the number of designated spots and their size for allocation. Therefore, candidates concerned must contact the relevant RO to register their interest in writing when they submit their nomination forms. Similarly, the same arrangements apply to the lists of candidates in a GC election, but on the basis of the lists.

8.28 Designated spots are allocated by agreement of the representatives of all the contested candidates of a constituency or GC lists or by the drawing of lots. After allocation of the spots and the necessary authorisations have been obtained from the relevant authorities [s 104A of Cap 132 and s 4 of Cap 28] and after complying with the requirements set out under Part V, the candidate/GC list may display EAs at such spots allocated to him/it.

8.29 A copy of all the permissions or authorisations obtained by a candidate himself, as opposed to those provided to him by the RO, must be provided by him to the relevant RO **before the display or distribution** [s

102(10)(a) of the EAC (EP) (LC) Reg].

8.30 Designated spots allocated are not transferable. Nor are they exchangeable with other spots. Where a candidate of a particular constituency informs the RO of that constituency in writing that he no longer wishes to use one or more of such designated spots allocated to him, upon request by any other candidate of the same constituency, the RO, if he considers appropriate, will re-allocate by agreement or by the drawing of lots the designated spots amongst all candidates of the same constituency except the one first mentioned. In such a case, paras. 8.28 and 8.29 above apply.

NOTE :

In some cases, designated spots allocated in the first round of allocation are left unused for various reasons. The RO may re-allocate such spots to the relevant candidates by mutual consent or the drawing of lots. Candidates may wish to plan accordingly their resources in respect of EAs.

8.31 Authorisation to display will generally not be given to a GC list of a GC in respect of spots outside the constituency in which the GC list stands, save in exceptional circumstances, as directed or decided by the CEO. The CEO may in principle agree to display outside a particular constituency generally or upon application by a GC list of candidate(s). A GC list who wishes to apply for display outside its constituency should write to the CEO to state the reasons for its application as soon as possible after its nomination paper has been handed in, so that (if the CEO agrees in principle) there may be sufficient time for the RO for the constituency to include spots outside the constituency in an allocation exercise.

8.32 An EA advertising two or more lists of candidates of different GCs jointly publishing it is, however, allowed to be displayed on the designated spots in the respective GCs allocated to such lists. Similarly, an EA advertising two or more FC candidates or both FC candidates and GC lists jointly publishing it is allowed to be displayed on the designated spots allocated to the candidates/lists concerned. Nevertheless, it is important to ensure that the total area of all the spaces actually occupied for joint advertisements and for advertising each one of the joined candidates/lists of candidates (ie measured by the dimension of EAs) does not exceed the total area of the designated spots allocated to each of the candidates/lists of candidates. Through joint advertisement, the candidates concerned have an equal opportunity to promote themselves at the election, and so each of the candidates would derive the same amount of benefit from the joint advertisement. The expenses incurred for the joint EAs will therefore have to be borne by the candidates concerned in equal shares as their respective election expenses. In this connection, it is important to note that only a candidate himself or his election expense agent may incur election expenses on his behalf [s 23 of the ECICO]. **Joint EAs should not, however, be displayed in the common parts of private premises**, in order to prevent confusing electors or causing them to make mistakes as to the identity of the candidates running for the constituency concerned, or to prevent dilution of the principle of fair and equal treatment of candidates.

PART IV : CONDITIONS AND LIMITATIONS ON DISPLAY

Name of the Constituency

8.33 To avoid possible confusion to electors, EAs of all candidates of the GCs and all the FCs must bear the name of the constituency for which the

candidate concerned is standing. Similarly, in respect of joint EAs, the name of the constituency (be it functional or geographical) should be stated clearly in relation to each of the candidates advertised. Either the full name of the constituency or its abbreviated name (to be advised by the RO for the constituency) may be used, dependent on the choice of the candidate for the constituency.

8.34 Likewise, all candidates should make known to the electors the name of their respective constituencies when they conduct joint canvassing activities.

Re-use of Old Publicity Boards

8.35 A candidate may re-use old publicity boards used at a previous election. However, any information in relation to the previous election, eg the candidate number, name of constituency, party affiliation and names of persons who supported the candidate at that election, should be fully obliterated before any old publicity board is re-used. This would not only avoid confusion to electors but would also help the candidate to avoid laying himself open to allegations of false claim of support of persons who might not have consented to support him at the current election. The cost incurred in refurbishing the old publicity boards will be counted towards the candidate's election expenses.

Size

8.36 EAs displayed at railings and fences must not exceed the height and length of these structures, and in no circumstances be more than 1 metre high and 2.5 metres long.

Mounting and Installation

8.37 The mounting and display of EAs must not cause any risk to life or property.

8.38 Permanent fixing devices, such as nails or insoluble glue, should not be used.

8.39 Use “tie-on” posters (rather than “stick-on” posters) to facilitate subsequent removal.

8.40 Do not stick posters on painted or varnished surfaces as their subsequent removal will cause damage or leave unremovable marks.

8.41 Do not erect any structure on pavements, eg nailing boards to the ground.

8.42 Owners or occupiers of a property including a government authority may specify the way in which EAs are to be displayed, and may require an indemnity against any claim or damage arising from the display of such materials.

Dismounting

8.43 All candidates should remove all their EAs displayed on government land/property **within 7 days** following an election. Failure to do so may result in prosecution being brought against the offending candidate and such advertisements removed and seized by the relevant authority. The **cost of removal** will be recovered from the candidate concerned and will be construed as **election expenses**. Relevant authorities will issue demand notes for the removal costs to the candidates concerned within 21 days after the election results have been published in the Gazette (normally the immediate

Friday after the polling day). This is to allow sufficient time for the candidates to include all these costs in their election returns which must be submitted not later than 60 days after gazettal of the election results [s 37 of the ECICO].

PART V : SERIAL NUMBERING, DECLARATIONS AND COPIES

Serial Numbering

8.44 Save where the exemption applies, all copies of each type of all EAs intended to be displayed or distributed by a candidate must be marked distinctly and legibly on the face with **consecutive serial numbers** starting from “1” [s 102(1) and (2) of the EAC (EP) (LC) Reg]. Printed materials are exempted from the requirement of serial numbering if each of them:

- (a) is of or smaller than A4 size, i.e. 30 cm x 21 cm;
- (b) is contained in a single sheet of paper; and
- (c) bears upon it the printer’s name and address, number of copies printed and date of printing.

Examples of the above may include handbills, leaflets and simulated ballot papers. EAs printed in a registered local newspaper/magazine or sent to electors through the free postage service [see Part IX below] or transmitted by electronic means (eg facsimile, electronic mail, computer network, electronic display boards) and balloons, badges and carrier bags, head-dress and clothing are exempted from the requirement of serial numbering [s 102(15A) of the EAC (EP) (LC) Reg].

8.45 The size of the number marked on each type of EAs which are not larger than 60 cm x 42 cm (A2 size) must not be smaller than 2 cm in diameter, and the size of the number marked on those which are larger must not be smaller than 4 cm in diameter.

Declarations

8.46 **Before display, distribution or otherwise use of any EA**, a candidate must make a **declaration in a specified form** to the RO for his constituency (or to the CEO, if the RO has not yet been appointed) declaring the **quantity**, with the **serial numbers** (save those covered by the exemption referred to in para. 8.44 above), of each type of all EAs intended to be displayed, **the date of printing/publication and the name and address of the printer**. Such declaration should also show all the **intended places** of display (designated spots or private spots) which may be identified by reference to the permissions or authorisations obtained by the candidate. [S 102(3), (4) and (5) of the EAC (EP) (LC) Reg.] A candidate can submit as many declarations as circumstances may from time to time require. A candidate must ensure the correctness and accuracy of all the details contained in his declarations.

8.47 Where an EA is to be distributed by facsimile transmission and where the exemption referred to in para. 8.44 applies (which includes EAs sent to electors through the free postage service detailed in Part IX below or transmitted by electronic means), it will not be necessary to state the serial numbers in the declaration. Only the quantity of the EA is to be stated in the declaration.

8.48 A candidate must ensure that every time the contents of his website are changed or updated, he must make a new declaration to the RO and

deposit 2 hard copies of the modified pages with the RO accordingly (see also para. 8.49(a)(iii) below).

Copies

8.49 **Before display, distribution or otherwise use of any EA**, a person, including a candidate must deposit with the RO for his constituency (or with the CEO if the RO has not yet been appointed):

(a) in respect of election advertisements

- (i) 2 copies of all printed advertisements bearing in Chinese or English, the name and address of the printer together with the date of printing and the number of copies printed (“printing details”),
- (ii) 2 identical copies of any video/audio tapes or discs or diskettes containing EAs,
- (iii) 2 hard copies of any electioneering message sent by electronic means (including 2 hard copies of any modified webpages if the contents of the website are changed or updated), and
- (iv) 2 identical postcard sized colour photographs of each type of EAs which cannot be practically or conveniently photocopied;

[s 102(6), (7) and (9) of the EAC (EP) (LC) Reg]

(b) in respect of permissions or authorisations for display

a copy of all permissions or authorisations for display given or obtained for the purposes of s 104A of Cap 132 [s 102(10)(a) of the EAC (EP) (LC) Reg]; and

(c) in respect of consent of support

a copy of all consents of support referred to in s 27(1) or (2) of the ECICO, as the case may be [s 102(10)(b) of the EAC (EP) (LC) Reg].

8.50 In the rare circumstances where candidates contesting different constituencies use identical copies of an EA, the RO of the relevant constituency may exercise his discretion to accept a joint declaration by all the candidates concerned and a joint submission of two copies of the EA.

8.51 Where a Declaration of EAs under s 102 of the EAC (EP) (LC) Reg made by a candidate and deposited with the relevant RO contains a mistake or where the candidate's declared intention as to the number of any type of EAs to be displayed or the location of display, etc has changed, the candidate should make a corrective declaration to correct the mistake or record the change. All such corrective declarations must be deposited with the relevant RO at the **latest by 12 noon on the day preceding the polling day**. If no corrective declaration has been so deposited, then the declaration of EAs will be used as one of the bases for examining and checking the candidate's return and declaration of election expenses and donations, and as the basis for removal of unauthorised or offending displays.

8.52 No EAs shall be displayed apart from those referred to in the declarations made by the candidate and as shown by the copies or on the photographs.

8.53 A candidate must not display his EAs other than at the places set out in his declaration.

8.54 The RO for each constituency will make available a copy of the declarations, EAs, photographs, permissions or authorisations and consents at a specified address for inspection by the public as soon as practicable after such documents and photographs have been furnished until the expiration of the same period as declarations of election returns lodged by candidates are available for inspection under s 41 of the ECICO, ie until the first anniversary of the date on which the result of the relevant election is published, so that the two kinds of declarations can be checked and compared side by side [s 102(11) of the EAC (EP) (LC) Reg].

PART VI : REQUIREMENTS RELATING TO PRINTED ELECTION MATERIALS

Printing Details

8.55 S 34 of the ECICO requires all printed EAs, with the exception of those printed in a registered local newspaper/magazine to bear printing details, ie they must bear, in Chinese or English, the name and address of the printer together with the date of printing and the number of copies printed (“printing details”). It applies to all materials reproduced by any method of multiplying copies (eg printing machines, duplicators or photocopiers). The following are some suggested formats:

(a) Printed by ABC Printing Works,
XX XZY Street, HK
On (date) in (number) copies

or

(b) Printed by own office machine
XX XZY Street, HK
On (date) in (number) copies

Election Advertisements Placed in Print Media

8.56 Where an EA is placed in the print media and takes the form of a news report or any other form which does not clearly show that it is an EA, the words “Election Advertisement” or “選舉廣告” must be stated in the advertisement, to avoid misunderstanding by readers that it is not an EA.

PART VII : NON-COMPLIANCE AND CONSEQUENCES

Inadvertent Omission of Printing Details

8.57 A candidate who has inadvertently omitted the printing details from his EAs can make a statutory declaration giving the omitted details, and deposit such declaration with the relevant RO **not later than 7 days after** the publication of the offending EA [s 34(3) of the ECICO]. Having taken this remedial step, he will not be prosecuted for contravention of s 34(1) of the ECICO. The statutory declaration will be retained by the relevant RO for 6 months after the result of the election is published [s 34(7) of the ECICO].

Enforcement and Penalties

8.58 A candidate who fails to provide the printing details or deposit copies of printed EAs with the relevant RO commits an offence punishable by a fine of up to \$200,000 and imprisonment for up to 3 years [s 34(6) of the ECICO]. However, he may apply to the court for an order allowing the publication of the above EAs be excepted from the relevant requirements and relieving him from the penalties, provided that the court is satisfied that the non-compliance was due to inadvertence, an accidental miscalculation or any reasonable cause and was not due to bad faith [s 35 of the ECICO]. Non-compliance with the requirements of s 102 of EAC (EP) (LC) Reg is punishable with a fine at level 2 (up to \$5,000) and imprisonment for up to 6 months.

8.59 Each candidate must observe and comply with the conditions imposed by the permissions or authorisations for the display of EAs. Any EAs displayed in contravention of these guidelines may be removed or seized.

Candidates and their supporters should report any non-compliance to the RO and should not take removal action themselves.

8.60 Any unauthorised or offending EAs displayed may be seized, disposed of, destroyed, covered or obliterated by the relevant authorities as they think fit [s 102(15) of the EAC (EP) (LC) Reg]. The candidate or his election agent responsible may also be prosecuted and if convicted, may be liable to a fine or imprisonment. The cost of removal, being a civil debt, will be counted as election expenses. Such civil debt must be reported to the relevant RO in the candidate's return and declaration of election expenses. The seized articles may be kept as evidence and will be disposed of or returned upon application, in accordance with Cap 132 or the Housing Ordinance (Cap 283), as the case may be, and the procedures of the relevant authority. [S 104C of Cap 132 and s 6 of Cap 28.]

8.61 Each candidate must observe and comply with the conditions agreed between him and the owner or occupier of private land or property for the display of EAs, and any additional charges or damages that a candidate is liable to pay to the owner or occupier may be construed as election expenses.

8.62 Complaints should be made to the relevant RO. Upon complaints being received, the EAC may also issue public statements in such manner as it deems fit to censure or denounce any non-compliance with these guidelines. Although a censure may be a further detriment to the candidate in addition to his liability for removal expenses and criminal liability, the EAC will not hesitate to publish one in an appropriate case.

PART VIII : ADVERTISEMENTS OF POLITICAL, PROFESSIONAL/ TRADE BODIES OR OTHER ORGANISATIONS

8.63 Any thing or material published by any organisation, including political organisation, professional or trade organisation, owners corporation, mutual aid committee, tenants association, owners committee, etc (irrespective of whether or not the candidate concerned is its officer or member) which advertises its platform or services during or **even before the election period with reference to the candidate** by name or photograph or otherwise may be treated as EA put up by, or on behalf of, or on account of the candidate. The expenses for doing so may be construed as election expenses incurred by or on behalf of the candidate. It is therefore a prudent step for the relevant organisations to suspend their advertising activities. However, if the material published by the organisation concerned, as opposed to the candidate himself, advertises only a particular activity, which:

- (a) is organised from time to time either as part of the organisation's normal functions, and/or according to the local tradition;
- (b) is not related to the election; and
- (c) does not explicitly or implicitly promote or prejudice the election of a candidate in the election,

then the appearance in the published material of the name and/or photograph of a candidate who is involved in organising the activity should not be regarded as an EA.

8.64 It is an offence for anyone to incur election expenses unless he is a candidate or an election expense agent of a candidate [s 23 of the ECICO].

8.65 Candidates should protect their own interest by advising their political bodies or their organisations of these guidelines as soon as they have any intention or plan to run for an election.

8.66 To sum up the important points, where any organisation, including a political organisation, publishes an EA promoting a candidate,

- (a) the expenses incurred will be treated as the candidate's own election expenses;
- (b) the officer-in-charge of the organisation needs to be authorised by the candidate to be the candidate's election expense agent, or else it or the responsible person commits an offence under s 23 of the ECICO;
- (c) such advertisement must comply with the requirements of s 34 of the ECICO and s 102 of the EAC (EP) (LC) Reg; and
- (d) such advertisement can only be displayed at the spots authorised to the candidate.

PART IX : FREE POSTAGE FOR ELECTION ADVERTISEMENTS

Conditions for Free Postage

8.67 A list of candidates for a GC or any FC who is validly nominated in the notice of nomination published in the Gazette in accordance with regulations made under the EACO is permitted to post free of postage **one** letter to each elector in the constituency for which it/he is nominated [s 43 of

the LCO]. However, before the publication of the notice of nomination, a candidate wishing to exercise his right to free postage may be required to furnish the Postmaster General with a security for the payment of postage in the event that his name is not subsequently shown in the notice [Regulation 6(2)(a) of the Post Office Regulations].

8.68 The purpose of the free postage is to enable the candidate to mail EAs to promote or advertise himself and in relation to that election to electors in the constituency. The free postage, which is the candidate's own privilege, cannot and should not be used for any other purpose or any other election or for promoting or advertising any other person.

8.69 Specifically, the letter must:

- (a) be posted in Hong Kong;
- (b) contain materials relating only to the candidature of the candidate at the election concerned;
- (c) not exceed 50 grams in weight; and
- (d) be not larger than 175 mm x 245 mm and not smaller than 90 mm x 140 mm in size.

It is important to note that under s 101A(3)(a) of the EAC (EP) (LC) Reg, a candidate sending letters to electors in bulk is liable for payment of postage for all letters in that bulk if any letter in the bulk does not meet requirement (a), (b), (c) or (d) above.

Make-up

8.70 The letter may take the form of envelope, lettergramme, card or folder. Items in roll form or enclosed in plastic wrappers are not acceptable.

8.71 Cards and folders must be made of ordinary cardboard or paper not less than 0.25 mm thick, and must be rectangular in shape.

8.72 When a wrapper is used, it must extend over the full length of the item which it encloses. Envelopes must not be fastened with staples or with paper fasteners with sharp edges or points, but they may be closed by means of an adhesive flap or tape.

8.73 Envelopes, folders and lettergrammes having an opening large enough to entrap smaller letters are prohibited. **Unsealed mail item** contained in envelopes with ordinary tuck-in flaps may be used up to the following size limits (s 6 of the Post Office Guide):

Not over 90 mm in depth – opening not over 150 mm in length

Not over 100 mm in depth – opening not over 140 mm in length

Over 100 mm in depth – opening not over 115 mm in length

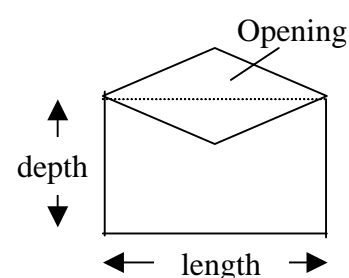

8.74 Folders of A4 size with openings should be closed by means of adhesive flap or tape so as to avoid entrapping smaller letters. For details, please refer to the illustration in **Appendix E**.

8.75 The characters “選舉廣告” or words “Election Advertisement” must be printed on the address (front) side of the envelope, or the address side of the folder (unenveloped advertisement).

Addressing

8.76 To avoid delay or misdelivery, the full postal address should be typed or legibly written on the front of the envelope in four rows as follows:

Name of addressee

Floor and flat number and name of building

Street number, name of street

Name of district

8.77 Addressing slips may be used for the mailing of EAs provided that they are legible and **securely pasted** onto the envelopes.

8.78 The name of the candidate and other propaganda slogans, including photographs, should appear on the back of the item or on the left-hand half of the address side reserving the right-hand half of the front exclusively for the address.

8.79 No postage-free EA bearing an address outside Hong Kong will be accepted.

Posting Arrangements

8.80 In order to allow adequate time for the Post Office to process the extremely large volume of election mail during the election period, candidates are advised to make their postage-free EA postings **14 working days before the polling day** at a post office located within their delivery district as

specified in **Appendix F**. Candidates and their agents are therefore **warned** that **postings made after the above deadline may fail to reach the addressees before the polling day.**

8.81 At least **2 clear working days' notice** must be given to the respective Manager (Retail Business) listed at **Appendix F** before the postings are made. Candidates should present two unsealed specimens of their EAs, together with a notice of posting of election mail (which will be provided by the REO at the time of candidates submitting their nominations), for inspection 2 clear working days before the postings are made.

8.82 When handing in the specimens, the candidates may indicate any one of the posting offices listed in **Appendix F** where they intend to make their postings. In this connection, the Manager (Retail Business) concerned will arrange and confirm the requests after approving the specimens.

8.83 The postings should be made up, preferably in bundles of 50 or 100 for easy counting. All letters should face the same direction. To facilitate handling of the huge volume of postings within a tight time schedule, **candidates of GCs** are required to segregate letters by way of the districts specified in **Appendix G** when presenting their postings.

8.84 With each posting, the candidate or his representative must present a signed declaration **in duplicate** (original to be kept by the Post Office and the duplicate copy duly signed by the Post Office official and kept by the candidate or his representative as acknowledgement of the posting):

- (a) stating the quantity of packets in the posting and the name of the candidate;
- (b) declaring that the posting is his postage-free communication;

- (c) declaring that each packet contains material relating to the election only; is identical to the unsealed specimen submitted by the candidate or his representative for inspection and retention by the Post Office; and is addressed by name to a duly registered elector in respect of the constituency for which the candidate has been nominated; and
- (d) declaring that not more than one postage-free communication has been or will be sent to any of the electors.

The declaration form will be provided to the candidates by the REO at the time of their submission of nominations. It is important to note that under s 101A(3)(b) of the EAC (EP) (LC) Reg, a candidate sending letters to electors in bulk is liable for payment of postage for all the letters in that bulk if the declaration made by him or his representative is false in any particular.

8.85 If a candidate makes posting in more than one batch, the same declaration form should be presented at the same posting office on each occasion.

8.86 Government reserves the right to charge a candidate postage where any of the above requirements is not met or the free postage arrangements are abused in any way [s 101A(3) of the EAC (EP) (LC) Reg]. The charge counts towards the candidate's election expenses and must be included in his return and declaration of election expenses and donations to be sent to the relevant RO. The EAC may also issue public statements in such manner as it seems fit to denounce any abuse of the free postage arrangements.

Enquiries

8.87 For general enquiries concerning the posting of EAs, please contact:

Senior Manager (Retail Business)

M/F, Middle Road Carpark Building,
15 Middle Road,
Tsim Sha Tsui,
Kowloon.

Telephone: 2926 1484

Fax: 2312 1455

CHAPTER 9

ELECTION MEETINGS

PART I : GENERAL

9.1 An **election meeting** is a meeting held to promote or prejudice the election of a particular candidate, a group of candidates or a list in a GC election [s 12(5) of the ECICO]. For the avoidance of doubt, election forums organised for all candidates in the same constituency are not treated as election meetings [see Part IV: Election Forums of Chapter 11].

9.2 Expenses incurred before, during or after the LegCo election on account of an election meeting organised for any of the purposes stated above are **election expenses**. There may be cases where a meeting is not organised for any of the above purposes, but has nevertheless been used for such purposes by a candidate or any other person on his behalf. In that event, it will be for the candidate to assess the expenses which have been incurred for the said purposes. [See s 2 of the ECICO and the guidelines on Election Expenses and Donations in Chapter 16.] The person who uses the meeting for promoting the candidate may also be liable for prosecution for his failure in obtaining the candidate's prior authorisation to appoint him as the candidate's election expense agent for incurring election expenses on behalf of the candidate [see s 23 of the ECICO].

9.3 Candidates should refer to the section on "Treating" in Part IV of Chapter 17, regarding the serving of drinks and meals at or incidental to an election meeting.

9.4 In addition to the election expenses incurred, candidates are responsible for the election meetings or public processions which they organise, including the keeping of order and safety, controlling noise level, cleanliness and other liabilities.

9.5 An election meeting may take place in a public place or in private premises. A public procession for election campaigning purposes is a form of election meeting, as is an exhibition organised with a view to promoting or prejudicing the election of a particular candidate or particular candidates.

PART II : NOTIFICATION TO THE POLICE

Election Meetings in Public Places

9.6 Any person who organises an election meeting in a public place must notify the Commissioner of Police in writing **not later than 11 am on the same day (if a general holiday, the first day preceding that day which is not a general holiday) of the week in the preceding week as the day on which the meeting is intended to be held** [s 8(1) of the Public Order Ordinance (Cap 245)]. “Public place” means any place to which for the time being the public or any section of the public are entitled or permitted to have access, whether on payment or otherwise, and, in relation to any meeting, includes any place which is or will be, on the occasion and for the purposes of such meeting, a public place [s 2 of Cap 245].

9.7 The written notification may be **handed in** to the officer in charge of any police station. It should contain the following particulars:

- (a) the name, address and telephone number of the person organising the meeting and any organisation promoting or connected with the holding of the meeting and a person able to act, if necessary, in place of the organiser;
- (b) the purpose and subject matter of the meeting;
- (c) the date, location, time of commencement and duration of the meeting;
- (d) an estimate of the number of people expected to attend the meeting;
- (e) the number and names of persons proposed as platform-speakers for the meeting;
- (f) the sound amplification devices, if any, intended to be used at the meeting; and
- (g) the nature, form and contents of the advertisements, printed matter, posters or banners intended for publication, distribution or display in respect of the meeting.

[S 8(4) of Cap 245.]

A **form** of notification for a public meeting or procession together with notes provided by the Police will be given to a candidate upon his submission of nomination. The Police has advised that the use of the form will speed up processing time.

9.8 Notification to the Commissioner of Police of an election meeting is not required if the meeting is to be:

- (a) attended by not more than 50 persons; or
- (b) held at the private premises where the number of persons attending will not exceed 500 persons; or
- (c) held in a school, college, university or other educational establishment with the approval of an accredited society or similar body of such school, college or educational establishment **and** consent of the governing body of the establishment concerned.

[S 7(2) of Cap 245.]

Where in doubt, a candidate should seek advice from the Police.

9.9 The Commissioner of Police may prohibit the holding of any public meeting notified (referred to in paras. 9.6 and 9.7 above) where he reasonably considers such prohibition to be necessary in the interests of national security or public safety, public order (*ordre public*) or the protection of the rights and freedoms of others, and if so, he shall give notice of the prohibition to the person who gave the notification not later than 48 hours prior to the time of commencement of the meeting [s 9 of Cap 245]. On the other hand, the Commissioner of Police may give notice to the organisers and impose conditions for the meeting to take place, and the organisers must comply with such conditions and comply forthwith with any direction given by a police officer for ensuring compliance with or the due performance of the conditions and the requirements referred to in para. 9.10 below. [S 11 of Cap 245.]

9.10 At every public meeting:

- (a) there shall be present throughout the meeting either the organiser, or if he is not present, a person nominated by him to act in his place;
- (b) good order and public safety shall be maintained throughout the meeting; and
- (c) the control of any amplification device that is used in such a manner that it causes a noise that would not be tolerated by a reasonable person, shall if so required by a police officer, be surrendered to the police officer for the duration of the meeting.

[S 11(1) of Cap 245.]

Public Processions

9.11 A public procession for election campaigning purposes may be held without notification to the Commissioner of Police:

- (a) where it consists of not more than 30 persons; or
- (b) where it is held at a place other than a public highway, public thoroughfare or public park.

[s 13(2) of Cap 245.]

9.12 In all other cases, written notification of a public procession, including a vehicle procession, must be given by the person organising the procession to the Commissioner of Police (which may be handed in to the

officer in charge of any police station) **not later than 11 am on the same day (if a general holiday, the first day preceding that day which is not a general holiday) of the week in the preceding week as the day on which the procession is intended to be held** containing the following information [s 13A(4) of Cap 245]:

- (a) the name, address and telephone number of the person organising the procession, any society or organisation promoting or connected with the holding of the procession and a person able to act, if necessary, in place of the organiser;
- (b) the purpose and subject matter of the procession;
- (c) the date, precise route, time of commencement and duration of the procession;
- (d) in respect of any meeting to be held in conjunction with the procession, the location, time of commencement and duration of the meeting; and
- (e) an estimate of the number of people expected to attend the procession.

A notification **form** mentioned in para. 9.7 should be used.

9.13 The Commissioner of Police may issue a notice of no objection for the public procession, or alternatively issue a notice of objection to the procession if he reasonably considers that the objection is necessary in the interest of national security or public safety, public order (*ordre public*) or the protection of the rights and freedoms of others. If the Commissioner of Police so objects to the public procession, he shall issue a notice of objection to the

organiser not later than 48 hours before the commencement time of the procession, otherwise he is taken to have issued a notice of no objection for the public procession. The Commissioner of Police may give notice to the organisers and impose conditions for the procession to take place, and the organisers must comply with such conditions and comply forthwith with any direction given by a police officer for ensuring compliance with or the due performance of the conditions and the requirements referred to in para. 9.14 below. [Ss 14 and 15 of Cap 245.]

9.14 At every public procession:

- (a) there shall be present throughout the procession either the organiser of the procession, or if he is not present, a person nominated by him to act in his place;
- (b) good order and public safety shall be maintained throughout the procession; and
- (c) the control of any amplification device that is used in such a manner that it causes a noise that would not be tolerated by a reasonable person, shall if so required by a police officer, be surrendered to the police officer for the duration of the procession.

[S 15(1) of Cap 245.]

Election Meetings in Private Premises

9.15 Any person who organises an election meeting at private premises should obtain prior permission from the owner, occupier, owners corporation, building management or the mutual aid committee etc concerned.

Housing estates under the management of the Housing Department and the Hong Kong Housing Society are treated as private premises in the guidelines.

9.16 Insofar as the decision regarding election meetings by candidates in the common areas of a building accords fair and equal treatment to all candidates, the EAC will not intervene.

9.17 Candidates must obtain **prior approval** from the Housing Manager before conducting any election meeting inside a housing estate, in addition to compliance with regulations and conditions imposed by other relevant authorities. An **application** for approval **should be made at least two clear working days (excluding Saturday, Sunday or public holiday) before the date of the meeting**, and the applicant will be notified as soon as practicable after a decision is arrived at. To avoid conflicts that may arise from allowing two or more candidates and their supporters to hold election meetings in a housing estate at the same venue and time, the Housing Department and the Hong Kong Housing Society will process the applications as soon as practicable and will adopt the following arrangements:

- (a) if only one application for holding an election meeting at a particular venue and at a particular time is received, that application will be approved;
- (b) if two or more applications for the same venue and the same period are received by the Housing Department or the Hong Kong Housing Society two clear working days before the activity takes place, applicants will be advised to negotiate among themselves to reach a compromise on condition that no canvassing from two or more groups will be held at the same place and at the same time to avoid any dispute or clash. If no compromise can be reached, allocation of venue or time will be

made by the drawing of lots at a time to be decided by the relevant estate Housing Manager;

- (c) for the purpose of (a) and (b) above, an application for several periods will be dealt with as separate applications for each of the periods; and
- (d) the Housing Manager should send a copy of the letter of approval to the respective RO for record and for public inspection.

9.18 Notification in writing to the Commissioner of Police will need to be given, in accordance with the procedure set out in paras. 9.6 and 9.7 above, if at the proposed meeting the attendance will exceed 500 persons.

PART III : MOBILE EXHIBITIONS

9.19 A candidate may hold an exhibition for election campaigning purposes. If such an exhibition is held at private premises, including public housing estates managed by the Housing Department and the Hong Kong Housing Society, the prior permission of the Housing Manager, owner, occupier, owners corporation, building management or the mutual aid committee etc concerned, as appropriate, must be obtained. Relevant guidelines in the other parts in this chapter should also be observed, in addition to compliance with regulations and conditions imposed by other relevant authorities.

9.20 Where approval has been given by a Housing Manager for such an exhibition, the display of EAs at the venue of the exhibition will normally be subject to the conditions that they are displayed in connection with the

activity in question and for a temporary duration of less than a day. The guidelines in Chapter 8: Election Advertisements are applicable to such displays and must be observed by the candidate concerned. The Housing Manager should send a copy of the letter of approval to the respective RO for record and for public inspection.

PART IV : FUND RAISING ACTIVITIES AT ELECTION MEETINGS

9.21 A permit is required for organising, providing equipment for, or participating in any collection of money or sale of badges, tokens or similar articles or exchange the same for donations in a public place [s 4(17) of the Summary Offences Ordinance (Cap 228)]. Any person who wishes to raise funds at an election meeting for non-charitable purposes should apply to the Secretary for Home Affairs. A copy of the administrative guidelines and licensing conditions for the issue of such permits with application form is at **Appendix H** for general information.

CHAPTER 10

ELECTIONEERING AT THE LIVING OR WORKING PLACES OF ELECTORS, PREMISES OF ORGANISATIONS TO WHICH ELECTORS BELONG AND BUILDINGS WHICH ELECTORS FREQUENT

PART I : GENERAL

10.1 There are occasions when candidates may wish to target their electioneering activities at an individual elector or a group of electors at:

- (a) his/their living/working place(s);
- (b) the premises of the organisation(s) to which the elector(s) belong;
or
- (c) the building(s) which the elector(s) frequent.

These electioneering activities include visits to, personal contact with people, using amplifying devices to advertise in the common parts of the building, display or distribution of EAs and holding of election meetings at, the places mentioned above. Appendix K gives some kind of reference as to what activity is to be regarded as an electioneering activity. This chapter explains the rights of all concerned and appeals to the electors, the management bodies of the organisations to which the electors belong and the management bodies of the buildings which the electors frequent to **provide fair and equal treatment** to all candidates so as to ensure that elections are conducted fairly.

PART II : RIGHTS OF TENANTS AND OWNERS

Tenant's Right - His House, Flat, Office or Factory

10.2 The tenant who has exclusive possession of a house, flat, office or factory, and not the owner, has the right to allow or deny access by anyone to the place.

Owners' Right - the Common Parts

10.3 The **common parts** of a building (those parts to which exclusive rights of use or occupation do not belong to a particular owner or tenant) are usually under the control and management of the owners of the various units in the building. Where there is an owners corporation of the building incorporated under the former Multi-storey Buildings (Owners Incorporation) Ordinance or the present Building Management Ordinance (Cap 344), the control and management of the common parts are exercised by the owners corporation representing all the owners of the building.

10.4 The carrying out of the powers and duties and the acts of an owners corporation do not affect the rights of the tenants of the individual flats, offices or factories in the building except in relation to matters concerning the common parts. Candidates and tenants should note that as **a tenant** has exclusive possession of the unit that he occupies, he **has the right to invite anyone to visit his unit for any lawful purpose**, including electioneering, but he has no right to allow the invitee to approach other tenants' units, such as knocking on other people's doors, or to do anything in the common parts of the building, except for accessing and leaving his unit or for the purposes allowed by the owners.

Owners Committees

10.5 In some buildings, no owners corporation has been established, but instead an owners committee is formed. While an owners committee generally operates in the same manner as an owners corporation, its powers vis-à-vis the rights of the individual owners are not standardised and may differ from case to case.

Management Companies

10.6 Very often, the management of the common parts of a building has been delegated by the owners or owners corporation or owners committee to a management company. Management companies are only managing the common parts on behalf of the owners and unless specifically empowered to do so, have no independent right or power to decide whether electioneering by candidates in the common parts should or should not be allowed.

Tenants Associations, Residents Associations, Mutual Aid Committees

10.7 Sometimes there are tenants associations or residents associations or mutual aid committees representing tenants' interests in buildings. As against the owners, they have no right to control or manage the common parts. If they are given the authority by the owners, then they are entitled to control and manage the common parts on behalf of the owners.

PART III : DECISION TO ALLOW OR DISALLOW ELECTIONEERING

10.8 Candidates should note that electors have the right to allow or

deny access by anyone, including the candidates, to their living or working places. In other words, electors are free to invite, or accept the request from, a particular candidate(s), but not the others, to visit them at their living or working places.

10.9 Any government offices will be treated in the same manner as the premises referred to in this chapter. Government offices may allow or disallow electioneering activities as they wish, but such decision should comply with the fair and equal principle mentioned in this chapter.

10.10 Unlike the living or working places of electors, the premises of the organisations to which the electors belong and the buildings which electors frequent do not belong to a particular elector or group of electors. They are usually under the control of the management bodies of the organisations or the buildings concerned.

10.11 On the polling day or even quite some time before, candidates and their supporters may wish to carry out canvassing or electioneering activities at the premises mentioned above. Such activities mainly consist of the following:

- (a) distribution of election leaflets or advertisements by delivering them into the flats themselves, or into mail boxes of the flats, or placing them in the common parts of the building for collection, or handing them out to residents or people in the common parts of the building (but not distribution by post which is not subject to the control of the private premises);
- (b) display of posters, banners, placards, boards and any other EAs, etc at any of the places within the common parts of the building;

NOTE :

Candidates who are allowed to display EAs at the premises mentioned above must comply with the guidelines set out in Chapter 8 : Election Advertisements.

- (c) personal contact with people or using amplifying devices to advertise in the common parts of the building; and
- (d) household or home visits to occupiers of flats.

10.12 **A tenant's right to invite lawful visitors to his own flat or office or factory cannot be lawfully restrained by any decision made by the owners or owners corporation.** If he invites a candidate and his supporters into his own place, the owners or owners corporation have no right to stop or obstruct it.

Decision to be Made at a Meeting with Tenants

10.13 During election time, there may be tenants wishing to entertain the approaches by candidates and their followers, but different tenants may invite different candidates to their units, and there may be arguments as to which candidate should be allowed to electioneer in the building. It is therefore advisable for owners or owners corporations to make a decision on whether to allow candidates and their followers to conduct electioneering activities in the building, so that arguments relating to who is allowed and who is not allowed to do so will be resolved for the benefit of all concerned. It is also advisable for owners or owners corporations to invite all the tenants to attend the meeting held for discussing this matter so that tenants' views will be heard before any decision to allow or deny electioneering activities in the building is taken.

10.14 As a motion on whether or not electioneering should be allowed in a building concerns the rights of tenants and occupiers more than those of owners, it is advisable for owners or owners corporations to allow occupiers who are not owners to vote on the motion and a secret ballot is always the fairest way of voting on such a controversial subject. If approval or consent has been obtained from the owners having the control of the common parts of the building or the owners corporation, the building management organisation may conduct a questionnaire survey to collect the views of the occupiers of each flat and act according to the majority view relating to matters covered by and in accordance with this chapter.

10.15 Candidates in an election see electioneering as a form of freedom of expression whereby they express to electors their platforms and the electors have a corresponding right to receive such information. Electors can only make a proper choice when casting their votes if they know the platforms of each of the contesting candidates.

10.16 If a decision is made to allow electioneering by all candidates, the decision can also set out the hours of access and other conditions, such as not causing annoyance to occupiers, and the maximum number of persons allowed for home visits, etc for the candidates to comply.

Decision Must Provide Fair and Equal Treatment

10.17 The EAC appeals to all management bodies of the organisations or buildings concerned to provide **equal opportunity** to all candidates or **GC lists** competing in the same constituency for the purposes of electioneering. However, if it is decided **not** to allow a particular candidate/GC list to conduct electioneering activities at the premises of the organisation or in the common parts of the building, no other candidate/GC list in the same constituency should be allowed to do so, for **it is important to provide fair and equal**

treatment for all candidates/GC lists so as to ensure that the election is conducted fairly. Discriminatory treatment of candidates may also lead to unequal treatment of tenants, and have the undesirable effect of giving rise to dissatisfaction and discord amongst neighbours in the same building.

10.18 Whatever organisation it is in such a building, be it an owners corporation, owners committee, mutual aid committee, tenants association, residents association, management company or managers of the building, the decision that it makes relating to electioneering activities of candidates in the common parts of the building, including the office premises of the organisation and all private streets, etc, **must comply with the fair and equal treatment principle.**

10.19 The organisation concerned should make a decision that applies equally and fairly to all candidates/GC lists of each constituency instead of dealing with each application from them separately. This will avoid having to convene a meeting to deal with each application upon its receipt, sometimes incurring delay in dealing with some applications. The EAC may treat such delay as a device to avoid compliance with the fair and equal treatment principle and may issue a reprimand or censure.

10.20 Even though such an organisation or any member of it may have reasons to exclude a particular candidate from the building, it should still adhere to the principle of fair and equal treatment for all candidates/GC lists competing in the same constituency without any discrimination.

10.21 The management bodies of the organisations or buildings concerned should avoid handling applications by candidates/GC lists for display of EA on a first-come-first-served basis as this may create unfairness. For example, if one candidate/GC list knows the decision and applies to put up posters and banners on all available spots in the common parts of the building,

no space will be left for other candidates/GC lists who apply after him. To ensure fairness, management bodies are advised to:

- (a) ascertain all the available spots at the premises for candidates/GC lists to display posters and banners;
- (b) after the close of nomination of candidature, find out from the RO how many candidates/GC lists are contesting in the constituency/constituencies concerned;
- (c) divide all the available spaces according to quality and quantity to ensure equality as far as possible into portions equivalent to the number of candidates/GC lists in the constituency/constituencies concerned; and
- (d) when one of the candidates/GC lists of the constituency concerned apply for display, allow him to draw lots to obtain a portion of the spots still available at the time of his application.

10.22 If a building has any spaces in the common area to **let** to candidates for them to display EAs or conduct other electioneering activity, the building shall ensure that such spaces are equally available to let to all the candidates contesting the same constituency, and give reasonable notice to all such candidates accordingly. Letting a space to only one of the candidates but not the others will be considered to be offering an unfair advantage to the candidate concerned and operating unfairly towards the other candidates. Candidates should not take any such unfair advantage.

10.23 Where a decision has been made, notice of its contents together with the conditions should be posted up at the entrance so that candidates or

their agents will be able to know. This openness will help prevent misunderstanding and complaint.

10.24 Whenever a decision has been taken by a building, insofar as the decision does not offend against the fair and equal treatment principle regarding electioneering activities of all candidates/GC lists of the same constituency, and such decision is not carried out unfairly towards any of the candidates/GC lists, the EAC will not intervene.

10.25 An owners corporation or other organisation or person should be very careful not to incur any election expenses for promoting a candidate/GC list, such as putting up a banner to show support for a candidate/GC list, because it is an illegal conduct at an election for a person, other than a candidate or a candidate's election expense agent, to incur election expenses at or in connection with the election [s 23 of the ECICO].

10.26 All persons who put up any publicity materials, including those which do not look election-related, in the nomination period on private premises should declare to the management body concerned whether they are candidates or intend to stand as candidates in the election. This is to prevent prospective candidates to make use of such device to promote themselves. The management body is also advised to exercise its own judgement whether the publicity materials are serving electioneering purposes and then make a decision with due regard to the fair and equal treatment principle.

PART IV : RESPECT FOR THE DECISION AND PRIVACY

10.27 After a candidate/GC list has been notified of the decision relating to electioneering, he should ensure that he and his followers comply

with the decision and should not avail himself of or obtain any unfair advantage over any other candidate/GC list. If a decision to disallow electioneering in an organisation or a building has been made, the candidate or his followers should conduct no electioneering activity in such places.

10.28 If the candidate concerned acts against the fair and equal decision of the organisation or building and electioneers in whatever manner, then he commits trespass and the organisation or building management can simply stop him from doing the contravening act or carry out the decision to exclude the candidates concerned. If the candidate refuses to leave, it would be wise in such circumstances for the organisation or building management, as the case may be, to report the matter to the Police and to the EAC or its Complaints Committee which may publish a **reprimand** or **censure** against the candidate concerned.

10.29 A candidate and his supporters should respect the decisions of the organisation or building management, and it is unwise to enter into **arguments** with members of the organisation or the building residents who obstruct the candidate's electioneering inside the premises of the organisation or the building. Such arguments may affect the candidate's reputation or image with members of the organisation or the residents of the building. Any dissatisfaction with the decision or act of the organisation or the building should more properly be made a subject of a complaint as soon as possible to the EAC or its Complaints Committee which will decide whether the decision or act is fair or unfair.

10.30 **Privacy of the electors should be respected.** Some do not like or detest being called over the **telephone** or the **entrance intercom system** and some do not like their names being called out aloud. Their disapproval may be reflected in their choice of candidates on the polling day. It is therefore unwise to telephone electors who find such approaches objectionable or to act

in any other way that may antagonise them. On the other hand, electors who receive the objectionable telephone calls can just disconnect them. If the caller does not desist from calling and causes a nuisance, the elector should report the matter as soon as possible to the **Police** who may take action against the caller.

10.31 Some candidates or their supporters may use **loud-hailers** to assist their campaign. They should exercise restraint in the use of loud-hailers so as not to create a nuisance to the persons in the vicinity, including those who live in the buildings nearby. Candidates are therefore required **NOT** to use loudspeakers in electioneering between 9 pm and 9 am. If the EAC comes to know that a candidate/GC list has breached the time restriction, it may make a reprimand or censure against the candidate/GC list. Excessive noise will amount to an offence and the Police may be called. Anyway, it is unwise to create a nuisance through the use of loud-hailers, for the annoyance of the electors will obviously be reflected in their choice of candidate.

10.32 Canvassing through the use of the **entrance intercom system** in a building is prohibited unless it is expressly allowed by the building.

PART V : OTHER RELATED PREMISES

10.33 Offices or notice boards of an organisation within a building or having control of the common areas of the building that are accessible to occupiers of the building are also treated as common parts of the building, and EAs displayed thereat must be treated in the same manner as those in the common areas. The fair and equal treatment principle applies.

10.34 Housing estates under the management of the Housing Department and the Hong Kong Housing Society are treated as private premises in these guidelines. These organisations all agree that as much access as possible for electioneering activities should be given to candidates in an equal and fair manner, but candidates will not be allowed to use loud-hailers in the corridors or any other places inside any housing block. The organisations will also adopt a consistent practice to be applied by Housing Managers regarding electioneering activities in the housing estates under their management. Candidates must, however, obtain **prior approval** from the Housing Manager before conducting any electioneering activities inside a housing estate, in addition to compliance with regulations and conditions imposed by other relevant authorities. An **application** for approval **should be made at least two clear working days (excluding Saturday, Sunday or public holiday) before the date of any intended activity**. Conditions such as the number of persons allowed to pay home visits to residents may also be imposed upon approval. Candidates must comply with the conditions. If a candidate is in serious or repeated breach of any condition, the Housing Manager will make a report to the EAC or its Complaints Committee for taking appropriate action. Application, approval and conditions are required for the following purposes:

- (a) to check whether the venue applied for is available at the requested date and time;
- (b) to check, and if possible to resolve in consultation with other relevant authorities, problems concerning public safety and crowd control;
- (c) to prevent difficulties or problems that may be created by two or more candidates and their supporters conducting possibly conflicting activities at the same time;

- (d) to avoid inconvenience or disturbance to the residents as a whole;
and
- (e) to prepare notices for residents' information.

10.35 To avoid conflicts that may arise from allowing two or more candidates and their supporters to hold election meetings in a housing estate at the same venue and time, the Housing Department and the Hong Kong Housing Society will process the applications as soon as practicable and will adopt the arrangements as specified in para. 9.17 of Chapter 9 : Election Meetings.

PART VI : NOTIFICATION OF DECISION

10.36 The management bodies of organisations and buildings are urged to notify the relevant RO in writing as soon as possible of their decision on electioneering by candidates, so as to equip the RO with the correct information to be provided to the candidates who may make inquiries with him. **A form of notification to the RO can be obtained from the REO. Where no notification is received by the RO after the expiration of the nomination period, he may assume that there is no objection from the organisation regarding electioneering by candidates in the building.** Enquiries may be made with the District Office or sub-offices of the District in which the building is located. Nevertheless, candidates are advised to note that some buildings may not be able to make a decision on electioneering by candidates before the close of nomination and therefore have not given the notification to the RO as required. When candidates come across these buildings, they should respect the interim decision of these buildings not to allow electioneering.

PART VII : IDENTIFICATION OF CANVASSERS

10.37 For security reasons and for prevention of abuse, the EAC advises that each candidate should provide some form of identification to his canvassers for them to enter the premises of an organisation or a building for electioneering purposes. The EAC suggests that the candidate should devise an authenticated identification document containing the name and photograph of his canvasser who should produce his identification document together with his identity card for inspection to gain entry into the premises of an organisation or a building. Candidates should note that the production costs of this kind of identification document will be counted as election expenses.

PART VIII : SANCTION

10.38 If the EAC receives a complaint of unfair or unequal treatment of candidates by any organisation or building or a person acting or purporting to act on behalf of such organisation or building, and is satisfied that the complaint is justified, it may make a **reprimand** or **censure** in a public statement which may include the names of the candidates/GC lists favourably and unfavourably treated. Candidates should therefore advise the organisation management or building owners whom they approach of these guidelines. On the other hand, however, if it is proved that a person has made a false, unfounded or unreasonable allegation of unfair treatment by an organisation or a building, the EAC may issue a reprimand or censure in a public statement against that person.

10.39 Candidates should also refrain from accepting any unfair advantage over other candidates in the same constituency even though such

may be ready on offer by an organisation or a building. The EAC may publish a public **reprimand** or **censure** against the candidate who contravenes the guidelines in this chapter or whose act or behaviour results in any unfair or unequal treatment by organisation or buildings towards any other candidate.

CHAPTER 11

ELECTION BROADCASTING, MEDIA REPORTING AND ELECTION FORUMS

PART I : GENERAL

11.1 This chapter deals with election broadcasting through electronic means (which covers all programmes including those on current affairs and news reporting on the radio and television), media reporting on election-related matters and the holding of any election forum.

IMPORTANT :

“Candidate” includes a person who has publicly declared an intention to stand for election at any time before the close of nomination for the election, whether or not he has submitted a nomination form [s 2 of the ECICO]. It also includes a list of candidate(s) in a GC list to which the list voting system of proportional representation applies.

PART II : ELECTIONEERING ON TELEVISION AND RADIO

11.2 Commercial broadcasters, including operators of television and radio channels, are generally not allowed to accept advertisements of a political nature.

11.3 For current affairs or other programmes on TV and radio which are not election-related, candidates/GC lists may take part freely in these programmes. Otherwise, the “equal time” principle will apply. “Equal time” means **equal time for each of the candidates/GC lists contesting in the same constituency.**

11.4 **No unfair advantage** should be offered to or obtained by any candidate/GC list over others regarding election campaigning.

11.5 When inviting a candidate/GC list to attend a programme whose entire or partial theme is on the election, broadcasters should include in the invitation a notice to the invitee that a similar invitation has been or will be made to other candidates/GC lists of the same constituency, so as to give the invitees an equal opportunity to appear. **A record should be kept by the broadcaster of the date, time and contents of the invitation and the notice until three months after the election.**

11.6 The principles stated in paras. 11.3, 11.4 and 11.5 above apply equally to political parties or political organisations of which the candidate or candidate(s) in a GC list are members and to the prescribed bodies which have given consent to their registered names or emblems to be printed on any ballot papers.

11.7 During the election period (ie the period beginning with the commencement of the nomination for the election and ending with the polling day for the election), broadcasters should ensure that the “equal time” principle as well as the “no unfair advantage” principle are applied to all political parties or political organisations which have members contesting the LegCo election and the said prescribed bodies, whether or not contesting the same constituency. If a political party or political organisation whose members contest as candidates in the election is invited to take part in a current affairs or any other

programme whose entire or partial theme is on the election, then all political parties or political organisations which have members contesting the LegCo election or prescribed bodies which have consented to their names or emblems being used on any ballot papers, whether or not contesting the same constituency, should also be invited.

11.8 The EAC appeals to broadcasters to treat all candidates/GC lists competing in the same constituency fairly and equally when making comment on or reference to the candidates in any of their programmes. If there is fair and equal treatment to all candidates of the same constituency, the editorial line of the broadcaster or personal opinions of the programme presenter on each of the candidates can be freely expressed, insofar as they are fair comments and based on true facts. The guidelines do not seek to impose any shackle on the expression of such ideas. However, broadcasters should ensure that in the expression of such ideas, no unfair advantage may result towards any candidate over another or any political parties or organisations to which contesting candidates belong.

Candidates Appearing on TV/Radio/Movie as Presenters, Regular Contributors, Actors, Musicians, Singers or Other Entertainers

11.9 A presenter or a regular contributor should not appear in any programme in his normal programme role after he has publicly declared his intention to stand for the election or during the election period if he becomes a candidate. This is to avoid unfair extra publicity for him at the critical time. A presenter or a regular contributor may, of course, appear as a candidate in election forums referred to in Part IV below.

11.10 A person who has contracted to appear as presenter, regular contributor, actor, musician, singer or any other form of entertainer in any performance scheduled to be shown before his declaration of intention to stand

for the election or before and after the election period may always do so and continue to do so. However, such a person should try his utmost endeavour to request the person(s) responsible not to broadcast his appearance in any media after his declaration of intention to run for the election or during the election period if he becomes a candidate.

Candidates Appearing in Commercial Advertisements

11.11 A person should not participate in the making of an advertisement in which his image, name or voice appear ("the relevant advertisement") and which he knows will be broadcast on TV/radio/cinema after his declaration of intention to stand for the election or during the election period if he becomes a candidate.

11.12 If, after the relevant advertisement has been made, the person then decides to run in the election, and it comes to his attention that the relevant advertisement will appear in TV/radio/cinema after his declaration of intention to stand for the election or after the nomination period has commenced if he becomes a candidate during that period, he should use his utmost endeavour to request the person(s) responsible not to broadcast the relevant advertisement after his declaration of intention to stand for the election or during the election period.

PART III : ADVERTISING THROUGH THE PRINT MEDIA

11.13 A candidate is at liberty to advertise in the print media to promote his candidature. Where such an advertisement is placed in the print media and takes the form of a news report or any other form which does not clearly show that it is an EA, the words "Election Advertisement" or "選舉廣告" must be

stated in the advertisement, to avoid misunderstanding by readers that it is not an EA [see para. 8.56 of Chapter 8 : Election Advertisements.] The expenses so incurred must be accounted for in the return and declaration of election expenses and donations.

11.14 No unfair advantage should be offered by any publisher to a candidate. Nor should a candidate obtain from a publisher any unfair advantage regarding election campaigning. The EAC appeals to members of the print media to provide **fair and equal treatment** to all candidates or GC lists competing in the same constituency in the reporting of them or their electioneering activities. How fair and equal treatment is to be applied in practice is set out in **Appendix I**.

11.15 A regular columnist should not contribute articles to the print media after he has publicly declared his intention to stand for the election or during the election period if he becomes a candidate. This is to avoid unfair extra publicity for them at the critical time. A regular columnist may, of course, appear as a candidate in election forums referred to in Part IV below.

PART IV : ELECTION FORUMS

11.16 During the election period, broadcasters may organise election forums in their programmes. Broadcasters should ensure that the “equal time” principle as well as the “no unfair advantage” principle are applied to all candidates/GC lists. If a candidate/GC list is invited to take part in the election forum, then all candidates/GC lists of the same constituency should also be invited to be present at such forums so as to give the candidates/GC lists an equal opportunity to appear.

11.17 Any organisations, such as professional or trade organisations, academic institutions and schools, etc, may also organise election forums for civic education or other purposes. In line with the fair and equal treatment principle, the EAC appeals to all these organisers to invite all candidates/GC lists of the same constituency to be present at such forums, so that no unfair advantage will be accorded to or obtained by any candidate/GC list over others regarding election campaigning.

11.18 The EAC also appeals to all candidates/GC lists to use their best endeavours to take part in election forums in order to enable electors and the public to be apprised of their platforms.

PART V : SANCTION

11.19 If the EAC comes to know of unfair or unequal treatment of candidates by any broadcaster, publisher or forum organiser, it may make a **reprimand** or **censure** in a public statement which may include the names of the candidates favourably and unfavourably treated and the broadcaster, publisher or forum organiser concerned. The EAC may also notify the relevant authorities for appropriate action to be taken.

CHAPTER 12

USE OF SOUND AMPLIFYING DEVICE AND BROADCASTING VANS

PART I : GENERAL

12.1 The law relevant to this chapter can be found in the Public Order Ordinance (Cap 245), the Summary Offences Ordinance (Cap 228), the Noise Control Ordinance (Cap 400) and the Road Traffic Ordinance (Cap 374).

12.2 Candidates are reminded that some members of the public find the sound or noise emitted by loudspeakers annoying and intrusive. When using loudspeakers, candidates should particularly bear in mind possible annoyance caused to people in hospitals, homes for the elderly, kindergartens, nurseries, schools and dwelling houses. Electors' choice of candidate in casting their votes may be affected as a result of any noise nuisance caused by candidates or their followers.

PART II : USE OF LOUDSPEAKERS AND BROADCASTING VANS

12.3 With effect from July 1995, the Commissioner of Police ceases issuing loudspeaker permits under s 4(29) of the Summary Offences Ordinance. Candidates are therefore **NOT** required to submit any application for a permit. However, this does not exempt candidates from complying with the requirements of the law and the conditions imposed by the Commissioner of Police when any amplification device is used in an election meeting or

procession. An amplification device includes a loudspeaker and any device which can emit or amplify sound. [Please refer to Chapter 9 : Election Meetings for details].

12.4 Although no permit is now required, any person using a loudspeaker should ensure that the noise emitted through the loudspeaker does not cause a nuisance to any other person. Under s 5(1)(b) of the Noise Control Ordinance, making a nuisance by using a loudspeaker, megaphone, or other device or instrument for magnifying sound from which the noise emitted is a source of annoyance either at any domestic premises or public place at any time of the day is an offence, and this includes use of loudspeakers attached to vehicles. In order to reduce the nuisance caused to members of the public, candidates are required **NOT** to use loudspeakers in electioneering **between 9 pm and 9 am**. If the EAC comes to know that a candidate/ list of candidates of a GC/GC list has breached the time restriction, it may make a **reprimand** or **censure** against the candidate(s)/GC list. Candidates should note that some members of the public may find the noise emitted from loudspeaker on broadcasting vans disturbing. They should therefore seriously consider the public's tolerance over the noise level and try to keep the noise volume at a reasonable level.

12.5 Should any complaint be received by the Police concerning the volume of the loudspeaker, the volume of sound should be reduced on the instructions of any police officer. If verbal warning or instruction by the police officer is ignored, prosecution may be instituted.

12.6 All vehicles used for and in connection with canvassing activities must comply with the provisions and regulations of the Road Traffic Ordinance. Drivers of such vehicles are obliged to obey all directions given by uniformed police officers and traffic wardens. Additionally, drivers of all vehicles must comply strictly with all the stopping and parking regulations of the Ordinance.

Deliberate slow driving may constitute “careless driving” as it could be deemed as driving “without reasonable consideration for other persons using the road”. Paraphernalia attached to a vehicle must also comply with the Road Traffic (Construction and Maintenance of Vehicles) Regulations of the Road Traffic Ordinance, ie not to interfere with the working or safety of the vehicle. Candidates and their supporters are reminded that they should observe the statutory requirements of the Road Traffic (Safety Equipment) Regulations and Road Traffic (Traffic Control) Regulations under the Road Traffic Ordinance, including those relating to seating requirement, the wearing of seat belts and the permission to carry passengers in a vehicle. Standing up in moving vehicles would be **illegal** for both the drivers and standees except on trams, single-decked public service buses and the lower deck of double-decked buses.

12.7 Any vehicle modified to a float configuration for display or canvassing purposes must be approved by the Commissioner for Transport. Application procedures for approval of float design are included at **Appendix J**.

12.8 Candidates should also note that the use of loudspeakers will not be permitted within the NCZ outside the polling station, nor will it be permitted in the vicinity where the sound emitted can be heard within the NCZ. [See also Chapter 14 : Prohibition Against Canvassing Activities outside Polling Stations.]

PART III : SANCTION

12.9 If the EAC comes to know that any candidate is in breach of the guidelines in this chapter, apart from notifying the relevant authorities for actions to be taken, it may make a **reprimand** or **censure** in a public statement

which may include the name of the candidate concerned. The censure may be in addition to the criminal liability for offences inside the NCZ, punishable with the maximum penalties of \$5,000 fine and imprisonment for 3 months [s 45 of the EAC (EP) (LC) Reg]. Candidates should also advise their political parties or organisations of these guidelines in their campaigning activities organised by such a party or organisation on behalf of the candidate.

CHAPTER 13

ELECTIONEERING ACTIVITIES CONDUCTED IN SCHOOLS OR PARTICIPATED BY SCHOOL PUPILS

PART I : GENERAL

13.1 Candidates, school supervisors, principals and teachers are requested to take note of these guidelines when considering allowing the conduct of electioneering activities in their schools or seeking the assistance of pupils in electioneering activities.

13.2 Involvement of school pupils in electioneering activities has always been a matter of public concern. Anybody in authority must **NOT** use his position to exert undue influence on youths of school age under his charge to recruit them for electioneering activities. If the EAC comes to know that a person has abused his position by involving youths of school age under his charge in electioneering activities, it may make a reprimand or censure against the person. For use of force or duress on a person's voting preference, see s 13 of the ECICO.

PART II : SCHOOL PUPILS

13.3 While it is for the promotion of civic education that school pupils are encouraged to take an interest in community affairs, including elections, it is considered undesirable for them to be involved in electioneering activities at too young an age. Unattended young children can cause control problems and,

particularly where large numbers are involved, or in overcrowded situations, can create a danger to themselves and others. The EAC therefore advises strongly against any pre-primary or primary school pupil taking part in electioneering activities.

13.4 Distribution of EAs is a form of electioneering activity. There may be school supervisors, principals or teachers who may support a particular candidate/GC list in a GC. While they are free to support any candidate or GC list they prefer, they should not distribute or help distribution of EAs of any candidate or GC list to the parents of pre-primary, primary or secondary pupils using the pupils as conduits. Moreover, they must not ask such pupils to request their parents to vote for any particular candidate or GC list. The same applies to candidates who are themselves school supervisors, principals or teachers. This guideline is based on the same principle stated in para. 13.2 above, and could avoid any semblance of undue influence on young children under the charge of these persons in authority in the school.

13.5 The EAC adopts the advisory circular issued by the Secretary for Education and Manpower to all schools for general guidance, emphasising the following points:

- (a) participation by pupils in electioneering activities must be **entirely voluntary**;
- (b) the **written consent** of a parent or guardian must be obtained beforehand;
- (c) in no circumstances should pre-primary or primary school pupils be asked to take part in such activities;

- (d) there should be no disruption of the pupils' education, and in no circumstances should normal lessons be interrupted to enable pupils to take part in such activities; and
- (e) in no circumstances should pupils be asked to take part in activities in areas where they may be subject to various elements of danger, including those created by traffic.

13.6 Pupils who take part in canvassing activities should pay attention to their own school regulations, and in particular those regarding the wearing of school uniform in such activities.

13.7 The EAC recognises that school pupils who are 18 years of age or over are by law old enough to be responsible for their own acts and make election-related decisions for themselves.

PART III : ELECTIONEERING ACTIVITIES IN SCHOOLS

13.8 During the election period, school supervisors, principals or teachers may invite or be approached by candidates to give talks on topical issues to students in their schools. The topic to be covered by such a talk may or may not have direct reference to an election. In any case, the presence of the candidate delivering it and the copies of the speech which may be circulated to students and brought home to their parents may have the effect of promoting or advertising that candidate or his GC list and should, therefore, be regarded as his electioneering activity. [See also para. 13.4 above.]

13.9 In line with the **fair and equal treatment** principle, the EAC appeals to all school supervisors, principals and teachers to provide equal

opportunity to all candidates/GC lists of the same constituency for the purpose of electioneering. If a school authority has decided to allow a particular candidate or GC list to conduct electioneering activities in the school, other candidates or GC lists of the same constituency should be informed and given the opportunity to do the same, so that no unfair advantage will be accorded to or obtained by any candidate over others regarding election campaigning. Information on the name and address (and contact numbers if the candidate has no objection to releasing the same) of candidates and GC lists can be obtained from the REO.

PART IV : SANCTION

13.10 If the EAC comes to know that any candidate or school or a person is in breach of the guidelines in this chapter, it may make a **reprimand** or **censure** in a public statement which may include the name of the candidate, the school and person concerned, and may also refer the case to the Education and Manpower Bureau. Candidates should therefore apprise the school or person concerned who offers them assistance of these guidelines.

CHAPTER 14

PROHIBITION AGAINST CANVASSING ACTIVITIES OUTSIDE POLLING STATIONS

PART I : GENERAL

14.1 This chapter deals with the ban on canvassing activities **outside** polling stations on the polling day.

14.2 A “No Canvassing Zone Scheme” is employed for the purpose of prohibiting canvassing activities outside polling stations on the polling day in order to maintain free and safe passage for electors, and to ensure that electors are not unduly harassed on their way to a polling station.

PART II : DECLARATION OF A NO CANVASSING ZONE AND NO STAYING ZONE

14.3 The RO for a GC must determine, in respect of each polling station designated for the GC and 28 FCs/SFCs an area outside the polling station to be a NCZ. In so doing, he will take into account the location of the polling station and the local geographical conditions. He must also determine an area within the NCZ outside the entrance to the polling station as a NSZ. These two zones are to be determined with reference to a map or plan [s 40(1) of the EAC (EP) (LC) Reg].

14.4 The RO who made the determination of declaring a NCZ or NSZ in respect of a polling station must, at least **7 days** before the polling day, give notice of the declaration to the candidates of his own constituency and to the ROs of other constituencies for which polling will be held in the polling station; and thereafter each of the ROs of these other relevant constituencies must give notice of the declaration to the candidates of his own constituency as soon as practicable [s 40(3), (4), (6), (7), and (8) of the EAC (EP) (LC) Reg].

14.5 The notice will be given in writing, either in person or by post or by facsimile transmission to the candidates (or in the case of a list of candidates in a GC, to any one of the candidates on the list) or to the election agents [s 40(14) of the EAC (EP) (LC) Reg].

14.6 Where the circumstances so warrant, an RO who has made a determination may vary the NCZ or NSZ. Notice of the variation must be given as soon as practicable after the variation in the same manner as a notice referred to in para. 14.5 above. However, a notice of variation need not be given to the candidates if it is not reasonably practicable to do so before the close of poll [s 40(13) of the EAC (EP) (LC) Reg].

14.7 A notice of the determination or the variation, together with indication of the boundaries of the NCZ or the NSZ, need to be displayed, on the polling day, at or near the relevant polling station, in order to make the determination or variation effective [s 40(10), (11) and (12) of the EAC (EP) (LC) Reg].

14.8 An RO who is empowered to determine NCZ and NSZ may authorise his ARO or the PRO of the relevant polling station to exercise the power to vary the determination and to perform the associated duties on the polling day. [S 92 of the EAC (EP) (LC) Reg.]

PART III : CONDUCT INSIDE THE NO CANVASSING ZONE AND NO STAYING ZONE

14.9 Door-to-door canvassing and for the purpose of such canvassing, the display of propaganda material, eg any badge, emblem, clothing or head-dress which may promote or prejudice the election of a candidate or candidates at the election, or makes direct reference to a body any member of which is standing as a candidate in the election or a prescribed body which has given consent to its registered name or emblem to be printed on any ballot paper, will be allowed on the storeys above or below street level in a building within a NCZ other than a building in which there is a polling station provided that permission has been obtained for entry to the building for canvassing votes, obstruction is not posed to electors and no amplifying device is used [s 40(16) of the EAC (EP) (LC) Reg]. Apart from this, no other canvassing activities will be allowed within a NCZ except for static displays of EAs that are authorised by the RO or the PRO of the relevant polling station. Where there are private premises situated within the NCZ, the ROs should issue a notice in advance to all the candidates in the constituencies concerned asking them to remove all of their EAs, if any, posted up at the private premises within the NCZ which can be seen by the electors on their way to the polling stations on the polling day. If the candidates fail to remove the EAs as requested by the ROs, the ROs may issue a warning to them to remove the offending EAs immediately. If the candidate or GC list fails to do so, the EAC may issue a censure or reprimand. Canvassing activities may take many different forms. A list of common canvassing activities which are forbidden in a NCZ is at **Appendix K**.

14.10 On the polling day, the PRO will use his best endeavour to ensure that no person carries out any activity other than those permitted activities described in para. 14.9 above in the NCZ in respect of his polling station to

persuade or induce any elector to vote or not to vote. Any unauthorised display of EAs in the area will be removed by the RO [s 102(15) of the EAC (EP) (LC) Reg]; and any person found to have conducted canvassing activities prohibited in the area will be asked to leave the area [s 41 of the EAC (EP) (LC) Reg].

14.11 The use of loudspeakers or loud-hailers will not be permitted within the NCZ, nor will any such device or any activity (eg lion dance) be permitted in the vicinity so that the sound emitted can be heard within the NCZ. Save for canvassing activities allowed in para. 14.9, candidates and their supporters are not allowed to pass, let alone shout, appeal message to persons while inside the NCZ. [See Part II of Chapter 12 regarding the use of loudspeakers.]

14.12 Within the NCZ but immediately outside the entrance of each polling station (and sometimes the entrance is also the same as the exit), there will be a **NSZ**, in which no person is allowed to stay or loiter, except where a person has been expressly permitted to do so by the PRO. This is for the purpose of securing safe and smooth passage of electors into and out of polling stations.

14.13 A person shall not obtain or attempt to obtain (in any manner) information as to which candidate an elector of the relevant polling station is about to vote for or has voted for, in a NCZ or in a NSZ without the express permission of the PRO who should have regard to exit pollsters who have complied with the requirements set out in Chapter 15 : Exit Poll.

14.14 Any person who misconducts himself or carries out any forbidden activity in a NCZ or NSZ, or fails to obey a lawful order of the RO (who has made the determination in respect of that NCZ or NSZ) or the PRO, commits an offence punishable with a fine and imprisonment and may be

ordered by such officer to leave the NCZ or NSZ [ss 45(4) and 41(2) of the EAC (EP) (LC) Reg]. If he fails to leave immediately, he may be removed from the relevant area by a police officer or by any other person authorised in writing by the RO or the PRO [s 41(3) of the EAC (EP) (LC) Reg]. The person so removed may not re-enter the NCZ or NSZ during that day except with the permission of the RO or the PRO [s 41(4) of the EAC (EP) (LC) Reg].

14.15 Nevertheless, the RO or the PRO shall not exercise their powers to remove an elector from the NCZ or NSZ so as to prevent him from voting [ss 41(5) and 44(14) of the EAC (EP) (LC) Reg].

PART IV : PENALTY

14.16 Any canvassing within a NCZ except those exempted, any attempt to obtain information as described in para. 14.13 without the necessary permission and any conduct prohibited under paras. 14.12 and 14.14 above will each be an offence under s 45(4) of, the EAC (EP) (LC) Reg, punishable by a fine at level 2 (up to \$5,000) and imprisonment of up to 3 months.

CHAPTER 15

EXIT POLL

PART I : GENERAL

15.1 This chapter sets out the guidelines for the conduct, publication and broadcast of exit polls to avoid unfair interference with the election process by unduly influencing electors. The aim is to ensure that elections are conducted honestly and fairly.

PART II : CONDUCT OF EXIT POLLS

15.2 The EAC appeals to the media and organisations concerned for self-regulation, goodwill and voluntary cooperation in the conduct, publication and broadcast of exit polls so that elector behaviour will not be unduly affected.

15.3 Exit polls may be conducted by any person or organisation. For the purpose of better control of the conduct of exit poll, persons or organisations intending to conduct exit polls must provide the following to REO at **the latest 7 days before the polling day**:

- (a) the name and address of the person or organisation intending to conduct exit poll on the polling day;

- (b) the identity document number and name of the person responsible together with his telephone number(s) for contact, especially for the polling hours; and
- (c) a list showing the number of persons who will be employed for the conduct of exit poll at each polling station on the polling day together with the identity document number and name of each of all the persons who will be so employed.

15.4 On the receipt of the application, the REO will consider the application and issue approval to the concerned person or organisation as appropriate.

15.5 Interviews are not allowed inside polling stations. Interviewers should note that canvassing activity is prohibited under criminal sanction within the NCZ except door-to-door canvassing activities on the storeys above or below street level in a building other than one in which there is a polling station provided that permission has been obtained for entry to the building for canvassing votes, such activities do not pose any obstruction to electors and no amplifying device is used. Interviewers must therefore be extremely careful in conducting exit poll so as not to give rise to any suspicion that they are canvassing electors inside the NCZ. Interviewers, like any other person, are not allowed to stay or loiter in the areas designated as the NSZ (within the NCZ but immediately outside the entrance to each polling station). Interviewers are also not allowed to accost electors in the NSZ. All these measures are for the purpose of securing safe and smooth passage of electors into and out of polling stations. If requested by persons conducting exit polls, the PRO of a polling station will, if circumstances permit, designate an area outside the exit of the polling station where interviewers can conduct exit poll.

15.6 Any announcement of results of exit polls or predictions, particularly in relation to any individual candidate or GC list, during the polling hours may affect elector behaviour and have an impact on election results. The EAC, therefore, appeals to the media and organisations concerned to refrain from announcing the results of exit polls or making specific remarks or predictions on the performance of individual candidate or GC list **until after the close of poll.**

15.7 Broadcasters' attention is invited to the provisions of the Television Code of Practice on Programme Standards which require news and current affairs programmes to be fair, objective and impartial.

PART III : SECRECY OF THE VOTE

15.8 The ballot is secret. It is an elector's right to keep his vote secret. An elector does not have to disclose his choice of candidate/GC list if he does not want to. It is a criminal offence for a person, without lawful authority, to require, or purport to require, an elector or authorised representative of a corporate elector to disclose the name of, or any particular relating to, the candidate/GC list for whom the elector voted at an election. [S 60 of the LCO.] Those who conduct exit polls must respect the electors' right and wish not to be disturbed.

PART IV : IDENTIFICATION OF INTERVIEWERS

15.9 There had been occasions where exit poll interviewers were mistaken to be government officials or polling staff. Such interviewers are

therefore required to wear an identification device so that electors will not be misled into thinking that they are appointed by Government.

15.10 After receipt of the information referred to in para. 15.3 above, the REO will notify the organisation or person concerned to collect a number of identification device bearing the name of the organisation that is required to be worn by each of the persons included in the list in para. 15.3(c) above when conducting an exit poll. Any person not wearing such a device or wearing such a device without the identity of the organisation being shown will not be allowed to conduct an exit poll outside any polling station.

PART V : SANCTION

15.11 Apart from the criminal sanction provided in the LCO, if the EAC comes to know that any broadcaster or organisation has failed to heed or comply with the guidelines in this chapter, it may make a reprimand or censure in a public statement which may include the name of the broadcaster or the organisation concerned.

CHAPTER 16

ELECTION EXPENSES AND DONATIONS

PART I : WHAT CONSTITUTES ELECTION EXPENSES

16.1 Provisions relating to election expenses can be found in the ECICO.

16.2 **Election expenses** mean expenses incurred or to be incurred **before, during or after an election**, by a candidate or his election expense agent on his behalf for the purpose of promoting his election, or prejudicing the election of another candidate or other candidates and include the value of election donations consisting of goods and services used for that purpose [s 2 of the ECICO]. The term “candidate” relating to election expenses (and donations) therefore includes a person **who has publicly declared an intention to stand for election** in respect of a constituency at any time before the close of nominations for the election, regardless of whether he has submitted his nomination form or after submission of the nomination form, his nomination is ruled invalid by the RO [s 2 of the ECICO]. A prescribed person who has applied under PCBP (LC) Reg to have his emblem registered should not, by that act alone, be treated as having publicly declared an intention to stand for election. As the list voting system of proportional representation applies to the election of the GCs, where GC lists instead of individual candidates will contest the election, a candidate who is on a GC list should pay attention to the special features applicable to the GC lists as set out in Part VII, although the law and guidelines in this chapter referable to candidates apply generally to the GC lists.

16.3 A candidate may receive **donations** for the purpose of meeting the costs of his election expenses. Donation, in relation to a candidate or candidates at an election, means any of the following donations:

- (a) any money given to or in respect of him for the purpose of meeting or contributing towards meeting his election expenses; or
- (b) any goods given to or in respect of him for the purpose of promoting his election or of prejudicing the election of another candidate or other candidates and includes any goods given incidental to the provision of voluntary service; or
- (c) any service provided to or in respect of him for the purpose of promoting his election or of prejudicing the election of another candidate or other candidates, but does not include voluntary service.

[S 2 of the ECICO.]

A donation to a candidate on a GC list will necessarily be a donation to all the individual candidates on the list jointly [see Part VII of this chapter]. All such donations, whether in cash or in kind, when spent or used, are counted as election expenses. [For details, see Part III of this chapter.]

16.4 There is no defined time as to when expenses are incurred whereby they will or will not be counted as election expenses. It is a question of fact in each case. For as long as an expense is incurred either for the purpose:

- (a) of promoting the election of a candidate; or

- (b) of prejudicing the election of another candidate or other candidates;

it will be an election expense, irrespective of when it is incurred, either before, during or after the election, and regardless of the source of funding.

16.5 A list of common expenditure items which may be counted towards election expenses is at **Appendix L**. The list is only illustrative and should not be considered as having precedence over the legislation. Whether a particular item of expenditure should be regarded as an election expense is a question of fact to be answered in the circumstances of each case. Each case should be determined by reference to the purpose behind the expenses, taking account of the nature, circumstances and context of the expenditure. Personal expenses incurred in the normal course of a candidate's daily life are not election expenses. Use of staff and other resources which are available to a candidate in his official capacity or at work for the purpose of promoting his candidature in the election should be counted as election expenses. Candidates should consult their legal advisers if they have doubt as to whether an expenditure item should count as an election expense. Any legal fees incurred as a result will not themselves be counted as election expenses.

16.6 A candidate should not use any public resources for the purpose of promoting his election or prejudicing the election of another candidate or other candidates at the election. However, any security, transportation, secretarial and living quarters services to which he is entitled to use for his private purposes by virtue of his post or job are not treated as public resources in this context.

PART II : WHO MAY INCUR ELECTION EXPENSES AND THEIR LIMIT

Maximum Scale of Election Expenses

16.7 The maximum scales of election expenses for elections for the different constituencies are prescribed by the Maximum Scale of Election Expenses (Legislative Council) Order made by the CE in Council pursuant to s 45 of the ECICO to limit the maximum amount of expenses a candidate/GC list may incur on account of the election. This limit controls the extent of election campaigns and serves to prevent candidates with ample financial resources from having an unfair advantage.

16.8 The maximum scales of election expenses are set out in the following table. For ascertaining the number of registered electors referred to in items (c), (d) and (e), inquiry can be made with the RO for the constituency concerned.

(a) for a GC election	(i) \$1,500,000 for a list in Kowloon East and Kowloon West GCs (ii) \$2,000,000 for a list in Hong Kong Island GC (iii) \$2,500,000 for a list in New Territories East and New Territories West GCs
(b) for an election for one of the following 4 SFCs, viz, Heung Yee Kuk, Agriculture and Fisheries, Insurance, and Transport FCs	\$100,000

(c) for an election for an FC other than those in (b) above with not more than 5,000 registered electors	\$160,000
(d) for an election for an FC with between 5,001 and 10,000 registered electors	\$320,000
(e) for an election for an FC with over 10,000 registered electors	\$480,000

16.9 A candidate must not incur any election expenses in excess of the maximum amount prescribed [s 24 of the ECICO]. Candidates on a GC list must not jointly or severally incur any election expenses in excess of the maximum allowed for each list for that GC, lest they will commit an illegal conduct.

Persons Authorised to Incur Election Expenses

16.10 Only a candidate or a person (including a fellow candidate on the same list in a GC election) who has been duly authorised by a candidate as the candidate’s election expense agent may incur election expenses [s 23 of the ECICO]. The authorisation should follow the procedures specified in Part VI of Chapter 7.

16.11 **Negative campaigning.** Before incurring expenses in carrying out any negative campaigning for or for the benefit of a candidate, a person will need the authorisation of the candidate to be the election expense agent of the candidate. Such expenses will be counted towards election expenses of the candidate. If the negative campaign includes EAs, all the requirements of

the ECICO and of the EAC (EP) (LC) Reg made by the EAC must also be complied with.

16.12 Candidates should advise the organisations with which they are associated and which may incur expenses to support them of these guidelines as soon as they have any intention or plan to run for an election, to avoid any offences being committed by these organisations out of ignorance.

16.13 A candidate will be responsible for the overall amount of his election expenses. In the event the total amount incurred by him and/or on his behalf is above the limit prescribed or above the limit he has authorised his election expense agent to expend, he will be liable for contravening the law, unless he can prove that the excess was incurred without his consent, beyond his authorisation, or not due to any negligence on his part. The election expense agent, on the other hand, should not incur an amount of election expenses which exceed the limit authorised by the candidate, lest the agent will contravene s 23 of the ECICO. [Ss 23 and 24 of the ECICO.]

PART III : DONATIONS

General Provisions

16.14 A person who has made known his intention to stand as a candidate in an election may receive donations for the sole purpose of meeting his election expenses.

16.15 Donations can only be used for meeting, or contributing towards meeting, a candidate's election expenses, or in the case of an election donation consisting of goods or services, for the purpose of promoting the election of the

candidate or of prejudicing the election of another candidate or other candidates [s 18 of the ECICO].

16.16 Donations can be in cash or in kind, and include any money's worth, any valuable security or other equivalent of money and any valuable consideration. All spent or used donations, whether in cash or in kind, which may be received before, during or after an election, are counted towards the total election expenses which are subject to the maximum amount prescribed.

16.17 Any unspent or unused donations must be given to charitable institution(s) or trust(s) of a public character chosen by the candidate(s). Any amount of donations that exceeds the upper limit of election expenses must also be given to such charitable institution(s) or trust(s). [S 19 of the ECICO.]

16.18 Since election donations can only be lawfully spent for meeting or contributing towards meeting election expenses, donations and expenses are often corresponding to each other. For every item of election expense which is avoided or reduced by obtaining the goods supplied or services rendered free of charge or at a discount, there should normally be a corresponding item of donation. The only exception is voluntary services obtained that are not treated as donations (any goods given incidental to the provision of a voluntary service will however be counted as an election donation). These points are elaborated in the paragraphs under Donations in Kind of this chapter.

16.19 On receiving a donation, of money or in kind, of more than \$1,000, a candidate must issue to the donor a receipt which specifies the name and address of the donor (as supplied by the donor). A standard form of receipt is obtainable from the REO and will be provided to a candidate or GC list at the time of his submitting the nomination form. While it is not uncommon that some donors would like to be anonymous, if a donation, in cash or in kind, is more than \$1,000, then only where the donor's name and

address (as supplied by the donor) are shown as required by the standard form of donation receipt can it be used as election donation. Donations exceeding \$1,000 or, in the case of an election donation consisting of goods, of more than \$1,000 in value received from anonymous donors must not be used for election expenses and must be given to a charitable institution or trust of a public character chosen by the candidate(s). [S 19(2) of the ECICO]

Donations in Kind

16.20 Donations in kind include goods and services obtained free of charge or at a discount. Unless the discount is generally available to all customers, the difference between the market/regular price and the price charged is a donation and must be declared and included as such and correspondingly as an election expense in the form of return. The same principle applies to loans obtained at no interest or at an interest rate lower than usual. Unless the facility is generally available to others, the interest not charged must be declared and included as a donation and election expense in the form of return. For premises provided free of charge to a candidate for his election campaign, a reasonable amount should be assessed as the deemed rental for the premises and such be included as a donation and election expense in the form of return.

16.21 For services or goods obtained free of charge, a candidate must include in the return their estimated value as if the expenses had been incurred. Where the services or goods are furnished by a person who deals in similar services or goods with the public, their estimated value should be assessed at the lowest price at which the person offers his services or goods to the public at the time when they are furnished. Where such services or goods are furnished by persons who do not deal in similar services or goods with the public, their estimated value should be assessed at the lowest market retail price at the time when they are furnished.

16.22 **Voluntary service** is the only service rendered free of charge which may be excluded from being counted as election expenses. In addition to being free of charge, the service must be provided by a natural person, voluntarily and personally, in his own time for the purpose of promoting the election of the candidate or candidates, or of prejudicing the election of another candidate or other candidates. [S 2 of the ECICO.] It must not be service normally provided by the person during such time for the purpose of earning income or profit. Otherwise, the service provided should be treated as a donation and counted towards election expenses at a fair estimated value.

PART IV : RETURN AND DECLARATION OF ELECTION EXPENSES AND DONATIONS

16.23 A candidate must keep an accurate account of all election expenses incurred and donations (whether in cash or in kind) received, and submit to **the CEO a return and declaration of election expenses and donations in a specified form (which will be given to a candidate upon his submission of nomination)** not later than **60 days** after the gazettal of the result of the election [s 37 of the ECICO].

16.24 The return must cover all the election expenses incurred by the candidate or the person(s) so authorised by him, services or goods obtained free of charge or at a discount and any unpaid claims. It must be submitted with supporting invoices and receipts for all payments each of \$100 and above. The copies of receipts issued by the candidate for any donations of more than \$1,000 and those issued by charitable institutions or trusts of a public character for the collection of any unspent or excessive donations should also be attached [s 37 of the ECICO].

16.25 At the time of his submitting his nomination form, a candidate will be given:

- (a) the specified form for making return and declaration of election expenses and donations mentioned in para. 16.23 above, together with a standard form of receipt for donations mentioned in para. 16.19 above;
- (b) the specified form for advance return of donations (see para. 16.28 below);
- (c) a specimen of the specified form with examples showing how the return and declaration can be completed; and
- (d) explanatory notes on how to complete the returns.

A candidate should read the explanatory notes carefully in completing the return, and make reference to the specimen whenever necessary.

Omissions and Mistakes

16.26 If a candidate is unable or fails to send to the CEO the return and declaration of election expenses before the end of the permitted period or omits an item in it or makes a mistake in it, and such inability, failure, omission or error was due to his own illness or absence or of the absence, death, illness or misconduct of any agent or employee of the candidate or by reason of inadvertence or accidental miscalculation or any reasonable cause (but not by reason of want of good faith of the candidate), he has the right to make an application to the Court of First Instance for an order to send in the return and declaration late, or to correct the omission or mistake [s 40 of the ECICO]. When the candidate finds himself in such a situation, it would be wise of him to

make the application to the Court and inform the REO as soon as possible. The legal costs so incurred will not be regarded as his election expenses. It is a corrupt conduct of a candidate to lodge a false or misleading election return [s 20 of the ECICO].

PART V : ADVANCE RETURN OF DONATIONS

16.27 A candidate, particularly a candidate who is a serving member of the LegCo or the DC, may give advance disclosure to the CEO of any donations received. This would enable such incumbent member to avoid any inadvertent contravention of the provisions of the POBO relating to the acceptance of “advantages”. The donations so disclosed must also be incorporated in the return and declaration of election expenses and donations to be submitted to the CEO not later than 60 days after the gazettal of the result of the election [s 37 of the ECICO]. The general provisions regarding donations in Part III must be observed.

16.28 Any **advance return of donations** must be made on the specified form mentioned in para. 16.25 above.

16.29 Depending on the time and the number of donations received, a candidate may submit any number of advance returns of donations to the CEO.

PART VI : FINANCIAL ASSISTANCE

16.30 Under the Financial Assistance Scheme for candidates and lists of candidates standing in LegCo elections in respect of election expenses,

candidates or lists of candidates who get elected or who have received 5% of valid votes or more will be eligible for financial assistance as follows –

- (a) in respect of candidates in a contested GC or FC, the amount payable is the lowest of –
 - (i) the amount obtained by multiplying the total number of valid votes cast for the candidates or list of candidates by the specified rate (now at \$10 per vote); or
 - (ii) 50% of the declared election expenses of the candidate or list of candidates; or
 - (iii) if the declared election expenses of the candidate or list of candidates exceed the declared election donations of the list, the difference in amount between those expenses and donations.

- (b) in respect of uncontested GCs or FCs, the amount payable is the lowest of –
 - (i) the amount obtained by multiplying 50% of the number of registered electors for the constituency by the specified rate (now at \$10 per vote); or
 - (ii) 50% of the declared election expenses of the candidate or list of candidates; or
 - (iii) if the declared election expenses of the candidate or list of candidates exceed the declared election donations of the

list, the difference in amount between those expenses and donations.

For both (a) and (b), if the declared election donations of a candidate or list of candidates equal or exceed the declared election expenses of the candidate or list of candidates, financial assistance is not payable. The broad procedural and documentary requirements for making a claim, and general conditions for payment to be made are provided in Part VIA of the LCO. The EAC (FA) (APP) Reg sets out the detailed implementation procedures for the Scheme.

16.31 Any financial benefit given by a political party (or, for that matter, any organisation or individual) to a candidate for the purpose of meeting, or contributing towards meeting his election expenses should be declared as an election donation and accounted for in the election return. Based on the election return submitted and the number of votes obtained, the CEO will calculate the amount payable as financial assistance in accordance with ss 60D and 60E of the LCO.

16.32 In case a candidate is offered, after he has filed his election return and after the statutory deadline for filing such return is passed, financial benefit from a political party with an understanding that it is to be used to meet all or part of his election expenses, he should apply to the court for permission to correct his election return under s 40(3) of the ECICO if the financial benefit is accepted. The CEO will take account of the revised election return in calculating the amount of financial assistance payable to the candidate.

16.33 Where the receipt of financial benefit from a political party has affected the amount of entitlement but payment of financial assistance has already been made, the CEO will require the candidate to repay the amount overpaid under s 60H of the LCO.

Making Claims and their Submissions

Requirements to be complied with when making claims

16.34 A claim for financial assistance will be made by a candidate or a list of candidates in a specified form (which will be provided by the REO at the time when candidates submit their nominations). It will be signed by an eligible candidate, or in respect of an eligible list of candidates by all candidates on the list. The claim form will be accompanied by –

- (a) an election return made under s 37 of the ECICO; and
- (b) an auditor's report which confirms that an auditor has audited the election return, and also the accounts of the declared election expenses and the declared election donations.

[S 3 of the EAC (FA) (APP) Reg.]

16.35 A set of guidance notes will be prepared by the REO with assistance by the Hong Kong Society of Accountants (“HKSA”) for auditors who are engaged by candidates to perform the auditing task. These notes will be issued by the HKSA to its members prior to the LegCo election.

16.36 Since the auditing fee is not incurred for the purpose of promoting candidature or prejudicing another candidate, it should not be regarded as an election expense. Accordingly, an elected candidate could accept an advantage to meet the auditing fee incurred and he would not be required to report the acceptance in his election return. S 4 of the POBO does not prohibit the acceptance of such an advantage *per se*, but if an elected

candidate decides to accept such an advantage, he should ensure that the acceptance is not in breach of the relevant provisions in s 4 of the POBO.

Submission of claims

16.37 The claim form, together with the accompanying documents, will be submitted in person at the office of the CEO by the candidate, one of the candidates of a GC list who has signed the claim form, or an election agent, within 60 days after the gazettal of the result of the election [s 4 of the EAC (FA) (APP) Reg].

Verification of Claims

Verification by CEO

16.38 On receiving a claim, the CEO will check the eligibility for financial assistance of the candidate or the list of candidates. He will also verify that the claim conforms to the requirements set out in the EAC (FA) (APP) Reg.

Requirement for further information

16.39 The CEO may require the claimant, through a written request, to provide further information to verify the claim. The claimant must provide the information within 14 days or within the period provided for in ECICO for lodging an election return, whichever is later. If the claimant fails to provide the information within the period, the CEO may stop processing the claim without any prior notice.

[see s 6 of EAC (EA) (APP) Reg.]

Part processing of claims

16.40 If an auditor's report states that only part of the election return complies with the requirements set out in the relevant sections of the ECICO, the CEO shall process that part of the return that complies with those requirements and may stop processing the part of the return that does not comply with those requirements [s 6 of the EAC (FA) (APP) Reg].

Withdrawal of Claims

16.41 A claim may be withdrawn before a payment of financial assistance is made by submitting a notice of withdrawal in person at the office of the CEO by the candidate, or by one of the candidates in the case of a claim made by an eligible list of candidates. The notice of withdrawal must be in a specified form and signed by the candidate, or by all the candidates in the case of a claim made by a list of candidates. [S 7 of the EAC (FA) (APP) Reg.]

Payment of Claim after Verification

Payment to be made by the Director of Accounting Services ("DAS")

16.42 After verifying the claim, the CEO will certify the amount of financial assistance payable on the claim and notify the DAS of the amount payable and the person to whom it is to be paid. As soon as practicable after receiving the notification, the DAS must make the payment in accordance with the notification. In the case of an eligible list of more than one candidate, the payment is to be made to the candidate who is nominated in the claim form to receive the payment on behalf of the candidates on the list. [S 8 of the EAC (FA) (APP) Reg.]

Recovery of Payment

16.43 Where a payment of financial assistance is made and the recipient is not entitled to receive the whole or part of the amount paid, the CEO is required to send a written notice under s 60H(1)(a) of the LCO by registered post to the recipient requiring repayment. The recipient may make the repayment, in person, at the office of the CEO or send the repayment by post. [S 12 of the EAC (FA) (APP) Reg.]

PART VII : SPECIAL FEATURES APPLICABLE TO THE LIST OF CANDIDATES IN A GEOGRAPHICAL CONSTITUENCY ELECTION

16.44 The guidelines in this chapter and the provisions of the ECICO apply generally to each and every candidate who is on a GC list. This Part draws attention of those candidates and their agents to the special features that are applicable to the GC list.

16.45 As stated in item (a) of para. 16.8 , a particular ceiling of election expenses applies to each of the GC lists in respect of a particular GC. The election expenses to be incurred by all the candidates on the GC list, or a single candidate on the GC list, cannot exceed the applicable ceiling, or else the candidate(s) on the GC list will be guilty of an illegal conduct under s 24 of the ECICO.

16.46 Any election expenses incurred by or on behalf of a candidate on a GC list for promoting the election of the candidate or list of candidates, or for prejudicing the election of another candidate or list of candidates, or any one of such candidates (see para.16.2 above) will necessarily be election expenses

incurred for the whole GC list, because they are not only incurred for a particular candidate, but for promoting or benefiting the election of the GC list in its entirety, regardless of the candidate's rank of priority on the GC list. An authorisation to an election expense agent, be he one of the candidates on the GC list or otherwise, to incur election expenses for a candidate on the GC list, therefore, must necessarily be an **authorisation** to incur election expenses for all the candidates on the GC list, and thus it needs to be **signed by all the candidates on the list**, and not just by the candidate alone. By the same reason, each candidate on the same GC list must authorise the other fellow candidate(s) to be his election expense agent(s), or otherwise none of the other fellow candidates can lawfully incur election expenses for him, or for the whole list which includes him. The election expenses incurred by any candidate on a GC list individually, whether before or after the formation of the list, form part of the election expenses capped by the applicable ceiling and must be counted towards the maximum amount allowed.

16.47 In order to ensure that each of the candidates on a GC list will cross-authorise one another as his election expense agent(s), such candidates will be required to sign a **return and declaration of election expenses already incurred and cross-authorisation form (which will be given to a candidate upon his submission of nomination)** and submit it to the relevant RO or the CEO, as the case may be, for the following purposes:

- (a) to declare the amount of election expenses each of them has already incurred for himself up to the time when the declaration is made;

- (b) to declare the amount of election expenses each of them and of the election expense agents is authorised to incur for the list for the election campaign which, taking into account the expenses already incurred as referred to in (a) above, should not exceed the election expense ceiling applicable to the GC; and
- (c) to cross-authorise each other and the election expense agents for the spending of the amounts to be incurred declared in (b) above.

All the candidates on the GC list must sign the declaration on the last page of the return before a Commissioner for Oaths or other authorised persons. It is important to note that the authorisation is not effective until it has been received by the relevant RO or the CEO, as the case may be. So long as the sum total of the amounts in (a) and (b) above does not exceed the applicable ceiling for the GC, the candidates on the GC list can decide the exact amount each is to expend for their campaign. However, candidates are advised that it would be wise to reserve a comfortable cushion below the ceiling when making the initial decision. The reason is that if any one of them wishes to expend above the amount to be incurred as declared in (b), this further expenditure could be covered by the cushioned amount. Moreover, since each candidate on a GC list is an election expense agent, he cannot by himself delegate to any third party to incur election expenses for the GC list. Any election expense agent must receive a written authorisation from **all** the candidates on the GC list **before** he can incur such expenses without contravening s 23 of the ECICO.

16.48 If there is any proposed alteration of the amount of election expenses any one of the candidates on a GC list has been authorised to incur under the cross-authorisation referred to in para. 16.47(b) above, all candidates of the GC list are required to sign another declaration form for the purpose and submit it to the relevant RO or the CEO, as the case may be. If there is any

proposed alteration of the amount of election expenses that any election expense agent has been authorised by all the candidates on a GC list to incur, the same procedure applies.

16.49 The reasoning set out in para. 16.46 above applies similarly to election donations. **All candidates** on a GC list are required to **sign a form of return and declaration of election expenses and donations** after the election. In the form, donations must include the amount of contribution each of them has made and donations from other sources for the election campaign for the promotion of the GC list. A particular section is included in the form specially with application to a GC list of candidates, who are required to complete and sign the form together. All the candidates on the GC list must sign the declaration on the last page of the return before a Commissioner for Oaths or other authorised persons. However, each candidate on the GC list is responsible for the amount of election expenses he has incurred and authorised by the other fellow candidates to incur, which must be stated in the return with supporting receipts.

16.50 Candidates from the FCs/SFCs need to complete a different form on return and declaration of election expenses and donations.

PART VIII : ENFORCEMENT AND PENALTY

Enforcement

16.51 The returns will be made available at the REO for public inspection up to the first anniversary of the date on which the result of an election is published. Copies of the returns will be furnished to any person

upon request subject to payment of copying fee at a fixed rate. [S 41 of the ECICO.]

16.52 Any complaint or report of breach of these guidelines may be made to the relevant RO, the REO or to the EAC or its Complaints Committee direct. The EAC or its Complaint Committee may, after consideration, refer the cases to the relevant authorities for investigation and prosecution.

16.53 The REO will check all returns of election expenses and donations. Irregularities detected will be reported to the relevant authorities for investigation.

Penalties

16.54 It is an illegal conduct for a candidate to incur election expenses in excess of the maximum amount prescribed. It is also an illegal conduct for a person, other than a candidate or a candidate's election expense agent, to incur election expenses. An election expense agent engages in illegal conduct if he incurs election expenses in excess of the amount authorised. Such illegal conduct is punishable by a fine of up to \$200,000 and imprisonment of up to 3 years. [Ss 22, 23 and 24 of the ECICO.]

16.55 A candidate who uses any donation for any purpose other than for meeting his election expenses, or fails to dispose of unspent or excessive donations in accordance with s 19 of the ECICO commits a corrupt conduct punishable by a fine of up to \$500,000 and imprisonment of up to 7 years. [Ss 6, 18 and 19 of the ECICO.]

16.56 A candidate who fails to submit the return and declaration of election expenses and donations by the prescribed date or who fails to provide an accurate account of all expenses incurred and all donations received with the

required supporting receipted vouchers and donation receipts commits an offence, punishable by a fine of up to \$200,000 and imprisonment of up to 3 years. [S 38 of the ECICO.]

16.57 A candidate who knowingly makes a materially false or misleading statement in his return and declaration of election expenses and donations or any advance return of donations commits a corrupt conduct punishable by a fine of up to \$500,000 and imprisonment of up to 7 years. [Ss 6 and 20 of the ECICO.]

16.58 A candidate, who having been elected to the LegCo, acts in the office or participates in the affairs of the LegCo without filing the return and declaration of election expenses and donations before the end of the permitted period commits an offence, punishable by a fine of \$5,000 for every day after such expiration on which he so sits or votes in such body. [S 39 of the ECICO.]

16.59 A person convicted of a **corrupt conduct or illegal conduct** within the meaning of the ECICO will be disqualified:

- (a) for 3 years from being registered as an elector or voting in the CE, LegCo, DC or VR election [s 26(d) of the Chief Executive Election Ordinance (Cap 569) (“CEEEO”), ss 31 and 53 of the LCO, s 30 of the District Council Ordinance (“DCO”) and s 16 of the Village Representative Election Ordinance (Cap 576) (“VREO”)];
- (b) for 5 years from being nominated as a candidate for the election of, or elected as, the CE, a member of the LegCo or DC or a VR [ss 14 and 20 of the CEEEO, s 39 of the LCO, s 21 of the DCO and s 23 of the VREO]; and

- (c) for 3 years from being nominated as a candidate for election of, or elected or nominated as, an Election Committee (“EC”) member from the date of conviction [ss 9 and 18 of the Schedule to the CEEO].

CHAPTER 17

CORRUPT AND ILLEGAL CONDUCT

PART I : GENERAL

17.1 This chapter sets out the guidelines against corrupt and illegal conduct in conducting election-related activities. It is important that candidates are aware of the common pitfalls in election activities, which may involve corrupt and illegal conduct, and take appropriate preventive measures to guard against committing offences out of oversight.

17.2 Provisions relating to corrupt and illegal conduct can be found in the ECICO. To help candidates and their agents to get acquainted with the major provisions of the Ordinance, the ICAC has prepared a Handbook on the Ordinance, which is at **Appendix M** for easy reference.

17.3 The ECICO and the guidelines in this chapter apply generally to the elections in respect of the FCs/SFCs, and the GCs. For the special features applicable to the system of the list of candidates in the GC election, please also see Part VII of Chapter 16.

17.4 A person who engages in:

- (a) a **corrupt conduct** will be liable to a fine of up to \$500,000 and imprisonment for up to 7 years and to pay to the court the amount or value or such part as specified by the court of any valuable consideration he or his agents received in connection with the conduct [s 6 of the ECICO]; and

- (b) an **illegal conduct** will be liable to a fine of up to \$200,000 and imprisonment for up to 3 years [s 22 of the ECICO].

In addition to these penalties, a convicted person will be disqualified from being registered as an elector or nominated as a candidate in elections, as appropriate. For details, please see para. 17.34 below.

PART II : CORRUPT CONDUCT RELATING TO NOMINATION AND WITHDRAWAL OF CANDIDATES

Offences relating to Candidature

17.5 Any act to affect a person's candidature by bribery, force, duress or deception is prohibited. Candidature includes standing as a candidate, not standing as a candidate, or withdrawal of nomination. It will be a corrupt conduct if a person corruptly:

- (a) offers an advantage to another person as an inducement or reward to affect his candidature or for not using his best endeavours to promote his election;
- (b) offers an advantage to another person as an inducement or reward to affect the candidature of a third person or get the third person not to use his best endeavours to promote his election;
- (c) solicits or accepts an advantage from another person as an inducement or reward to affect the candidature of himself or for not using his best endeavours to promote his election; or

- (d) solicits or accepts an advantage from another person as an inducement or reward to affect the candidature of a third person or get the third person not to use his best endeavours to promote his election.

[S 7 of the ECICO.]

17.6 Similarly, a person engages in corrupt conduct if he uses force or duress against another person to affect the candidature of that person or a third person. The use of deception to induce another person to affect the candidature of that person or a third person is also a corrupt conduct. [Ss 8 and 9 of the ECICO.]

17.7 It will also be a corrupt conduct if a person defaces or destroys a nomination paper with intent to prevent or obstruct another person from standing for election [s 10 of the ECICO].

PART III : ILLEGAL CONDUCT RELATING TO ELECTIONEERING

False Statement that a Person is or is not a Candidate

17.8 A person must not publish any statement that a candidate is no longer a candidate at an election if he is a candidate, or that another person who has been nominated as a candidate is no longer a candidate at the election, or that he or another person is a candidate at an election, knowing that the statement is false [s 25 of the ECICO].

False or Misleading Statement about a Candidate

17.9 A person must not publish any materially false or misleading statement of fact about a particular candidate or particular candidates for the purpose of promoting or prejudicing the election of the candidate or candidates. Similarly, a candidate must not publish any materially false or misleading statement of fact about himself or any other candidate for the purpose of promoting the election of himself or prejudicing the election of another candidate or other candidates. Any such publication will amount to an illegal conduct. It should be noted that materially false or misleading statements about a candidate or candidates include, but are not limited to, statements concerning the character, qualifications or previous conduct of the candidate or candidates, eg a person who makes a materially false or misleading statement contradictory to what a candidate has previously said, thereby calling into question the integrity and honesty of that candidate, may contravene the above provision. [S 26 of the ECICO.]

False Claim of Support

[Please also see Chapter 18: Namedropping.]

17.10 A candidate must obtain **prior written consent** from a person or an organisation before using the name or logo of that person or organisation, or a pictorial representation of that person in any of his EAs or activities as an indication of support from that person or organisation. Oral consent is **not** sufficient. [S 27 of the ECICO.] The EAC provides a standardised consent form for this purpose. Any indication of support in EAs, be it a text, a photograph or any other material, must be covered by a written consent from the person or organisation concerned. A copy of the consent form must be deposited with the relevant RO **prior to display, distribution or otherwise use of the EAs** [s 102(10)(b) of the EAC (EP) (LC) Reg]. It is important to note that it is still an offence even if such an EA contains a statement to the

effect that it does not imply support from the person or organisation concerned [s 27(4) of the ECICO]. It is also an offence for a person to give materially false or misleading information to a candidate or candidates for promoting or prejudicing the election of a candidate or candidates [s 27(6) of the ECICO].

17.11 A person or an organisation may give support to a GC list, to one or more of the candidates on a GC list, or to a single candidate on a GC list. Support can be also given to two or more candidates or GC lists, even if they are competing in the same constituency, although that may cause confusion. This should be specified in the written consent. A standardised consent form is at **Appendix N**. Candidates should take care to ensure that their EAs make clear where support is claimed whether it is for the whole GC list or for individual candidate(s) on the GC list. Candidates are reminded that it is an offence to make a false claim of support [see Chapter 18 : Namedropping].

17.12 Candidates on a GC list must be very careful in their EAs to describe **precisely** the support obtained by them or only one of them from supporters (as evidenced by a completed form of consent of support) to ensure that there is no false claim of support [see also para. 16.12 of Chapter 16].

17.13 A consent given can also be revoked. In case of a revocation, in order to avoid dispute, it is advisable for the person or organisation who has revoked the consent to send a notice or copy of the revocation to the candidate concerned and to the relevant RO. Every candidate is required to deposit a copy of the completed consent form with the relevant RO and to notify the RO in writing of any revocation of consent.

17.14 S 28 of the ECICO provides for an injunction order by the Court to restrain the publication of any materially false or misleading statement or false claim of support. An application for such an injunction order may be made by a candidate in the same constituency, his election agent, an elector in

the same constituency and the person or body to whom or which the false information is related.

Requirements relating to Printed Election Advertisements

17.15 Insofar as electioneering is concerned, it is an offence if a candidate does not comply with the requirements relating to printed EA. [For details of the requirements, please refer to Chapter 8 on Election Advertisements in particular Parts I, VI and VII thereof.]

17.16 A person must, **not later than 7 days after** publishing a printed EA, deposit **2 copies** of the advertisement to the relevant RO [s 34(4) of the ECICO].

17.17 The provisions of s 102 of the EAC (EP) (LC) Reg are more stringent. **Before** a candidate displays, distributes or otherwise uses an EA, he must allocate a **number in a separate series** to each type of EA, and make a **declaration** in a specified form to state the quantity of each type of EA he proposes to so use. For a better control over the display of unauthorised EAs and to facilitate the ROs in handling such complaints, the declaration and **2 copies** of the EA must be deposited with the relevant RO **before** the EA is displayed, distributed or used. If the relevant RO has not yet been appointed, the declaration and copies should be deposited with the CEO. By doing so, the candidate should have complied with s 34(4) of the ECICO as mentioned in para. 17.16 above.

PART IV : CORRUPT AND ILLEGAL CONDUCT RELATING TO ELECTIONEERING AND VOTING

Bribery

17.18 Any act to affect a person's voting preference by offering or soliciting or accepting an advantage is prohibited [s 11 of the ECICO]. Voting preference covers voting for a particular candidate or candidates, not voting at an election, or not voting for a particular candidate or candidates.

Treating

17.19 A person must not at any time provide or meet all or part of the cost of providing another person any food, drink or entertainment for the purpose of influencing that person's or a third person's voting preference. Likewise, the corrupt solicitation or acceptance of any such treating is prohibited. [S 12 of the ECICO.]

17.20 The serving of non-alcoholic drinks at an election meeting will not be deemed corrupt for the above purposes. [S 12(5) of the ECICO.] An election meeting is any meeting held to promote or prejudice the election of a particular candidate or particular candidates. See Chapter 9 : Election Meetings for details.

17.21 Treating arises in daily situations. If it is used (by a candidate or another person) for promoting or prejudicing the election of a candidate, it is an offence. For example, a person or an organisation may host a banquet for a non-election-related purpose but, during the occasion, innocently calls on the guests to vote for a particular candidate. In such an event, the candidate concerned should immediately disown or dissociate with whatever has been

said or done to promote his candidature. Otherwise, he would be liable to being charged with an offence under s 12 of the ECICO and the expenses so incurred would be counted towards his election expenses.

17.22 If a banquet, albeit apparently not related to any election, is used to treat guests corruptly for the purpose of promoting a candidate or prejudicing other candidates, then both the host and the candidate will be guilty of a corrupt conduct. Moreover, the host will commit an **offence** under s 23 of the ECICO if he has not yet been authorised in writing by the candidate to incur election expenses at or in connection with an election.

Force and Duress

17.23 The use of force or duress against a person to induce him to vote or not to vote at an election, or to vote or not to vote for a particular candidate or particular candidates or to get a third person to do so is a corrupt conduct. [S 13 of the ECICO.]

17.24 Persons in position to exert pressure and influence on others should be careful not to breach the provisions under the ECICO, eg employers over employees, school principals or teachers over students, religious advisers over believers and doctors over patients, etc.

Voting Offences

17.25 It is a corrupt conduct for any person:

- (a) to vote at an election knowing that he is not entitled to vote at that election;

- (b) to vote at an election after having knowingly or recklessly given materially false or misleading information to an electoral officer, or to vote at an election after having knowingly omitted to give material information to an electoral officer;
- (c) to vote at an election more than once except as expressly permitted by an electoral law; or
- (d) to invite or induce another person to commit (a), (b) or (c) above.

[S 16 of the ECICO.]

PART V : CORRUPT AND ILLEGAL CONDUCT RELATING TO ELECTION EXPENSES AND DONATIONS

17.26 Candidates should be careful when handling election expenses and donations as non-compliance with the relevant requirements will be a corrupt or illegal conduct. For details of the requirements that have to be observed, please refer to Chapter 16 : Election Expenses and Donations.

PART VI : POWER OF COURT TO EXCUSE INNOCENT ACTS

17.27 S 31 of the ECICO provides a mechanism for a candidate to apply for a Court order to relieve himself of criminal responsibility if he contravenes the illegal conduct provisions due to inadvertence, accidental miscalculation or any reasonable cause and was not due to bad faith. No

prosecution against him may be instituted or carried on until the application is disposed of by the Court. He will not be liable to be convicted of an offence if the illegal conduct is the subject of a Court order.

17.28 A candidate who fails to provide the printing details or deposit copies of EAs with the relevant RO commits an offence. However, he may apply to the court for an order allowing the publication of the above EAs be excepted from the relevant requirements and relieving him from the penalties, provided that the court is satisfied that the non-compliance was due to inadvertence, an accidental miscalculation or any reasonable cause and was not due to bad faith [s 35 of the ECICO].

17.29 A candidate who is unable or has failed to send to the CEO the return and declaration of election expenses before the end of the permitted period or omits an item in it or makes a mistake in it, and such inability, failure, omission or error was due to his own illness or absence or of the absence, death, illness or misconduct of any agent or employee of the candidate or by reason of inadvertence or accidental miscalculation or any reasonable cause (but not by reason of want of good faith of the candidate), has the right to make an application to the Court of First Instance for an order to send in the return and declaration late, or to correct the omission or mistake [s 40 of the ECICO]. When the candidate finds himself in such a situation, it would be wise of him to make the application to the Court and inform the REO as soon as possible.

PART VII : NON-COMPLIANCE WITH THE LAW AND SANCTION

17.30 Any complaint or report of breach of these guidelines may be made to the relevant RO, the REO or the EAC direct. The EAC may, after

consideration, refer the cases to the relevant authorities for investigation and prosecution.

17.31 The ICAC may, subject to the decision of the Secretary for Justice, prosecute, issue a warning or caution to candidates and any other persons in appropriate cases concerning any breach of the electoral law or regulation, especially the ECICO.

17.32 The Director of Public Prosecutions has informed the EAC that the Department of Justice will not hesitate to prosecute appropriate cases of electoral offences.

17.33 The EAC may also issue public statements in such manner as it deems fit to reprimand or censure any non-compliance with these guidelines.

17.34 A person convicted of a corrupt conduct or illegal conduct under the ECICO will, in addition to the penalties set out in para. 17.4 of this chapter, be disqualified:

- (a) for 3 years from being registered as an elector or voting in the CE, LegCo, DC or VR election [s 26(d) of the CEEO, ss 31 and 53 of the LCO, s 30 of the DCO and s 16 of the VREO];
- (b) for 5 years from being nominated or elected as a candidate for the election of, or elected as, the CE, member of the LegCo or DC or a VR [ss14 and 20 of the CEEO, s 39 of the LCO, s 21 of the DCO and s 23 of the VREO]; and
- (c) for 3 years from being nominated as a candidate for the election of, or elected or nominated as, as an EC member from the date of conviction [ss 9 and 18 of the Schedule to the CEEO].

17.35 It is worthy of note that the Courts of Hong Kong view election-related offences and contravention of the ECICO as serious crimes. On 27 November 1997, the Court of Appeal laid down sentencing guidelines that a person found guilty of any such offence should properly be sent to jail immediately for no less than 2 months (4 months for a candidate or an agent).

CHAPTER 18

NAMEDROPPING

False Claim of Support

[Please also see paras. 17.10 to 17.14 of Chapter 17 especially regarding GC lists.]

18.1 A candidate must obtain **prior written consent** from a person or organisation before using the name or logo of that person or organisation, or a pictorial representation of that person in any of his EAs or activities as an indication of support from that person or organisation. Oral consent is **not** sufficient. [S 27 of the ECICO.] The EAC provides a standardised consent form for this purpose. Any indication of support in EAs, be it a text, a photograph or any other material, must be covered by a written consent from the person or organisation concerned. The written consent is a requirement under the ECICO. It protects the candidates from unnecessary complaints and disputes which may arise if only oral consent is obtained. It also protects the electors from being misinformed as to whether a candidate has the support of a person or an organisation. Prior written consent is required if the inclusion of the name, logo or pictorial representation of a person or an organisation, as the case may be, implies support of the candidate concerned. What amounts to “support” will depend on the circumstances of each case. The question to consider is whether any reasonable man who has seen the pictorial representation would have the perception that the persons appearing in the EA support the candidate.

18.2 It is important to note that it is still an offence even if such an EA contains a statement to the effect that it does not imply support from the person or organisation concerned [s 27(4) of the ECICO]. It is also an offence for a

person to give information which he knows or ought to know is materially false or misleading information to a candidate for promoting or prejudicing the election of a candidate or candidates [s 27(6) of the ECICO].

18.3 To avoid confusion, it is advisable for the written consent to set out clearly whether consent is given:

- (a) by a person in his personal capacity - in which case no mention should be made of any office title which he may have, in the candidate's EAs and campaign activities;
- (b) by a person in his official capacity - in which case his office title may be used by the candidate concerned for the said purposes; and
- (c) by an organisation (which may be signed by an authorised person such as its director, chairman or chief executive, etc.) - in which case the name of the organisation may be used by the candidate concerned for the said purposes.

18.4 Care must also be exercised in the use of the office title of an individual and this should be cleared with the person concerned when seeking his written consent. In the case where an office-bearer of an organisation wishes to use his office title to support a candidate, he should be careful not to give the impression that it represents the support of the whole organisation except where a decision has been so taken in a general meeting of all the members of the organisation. This will prevent dispute and dissatisfaction amongst the members. Depending on circumstances, the approval of an organisation or a committee may or may not be needed if an office bearer uses his office title to support a candidate. If a supporter includes in an EA bears the title of "the principal of a school" (for example, "Chan Tai Man, the

Principal”) or “chairman of an owners corporation” (for example, “Chan Tai Man, Chairman of Owners’ Corporation”), it would not be necessary for the candidate to seek the consent of the owners’ corporation or the school concerned since there is no specific mentioning of which school or owners’ corporation. However, it would be desirable for the candidate to seek the organisation’s prior written approval as well if the EA is posted in the building or the school in which he is serving.

18.5 When a candidate has obtained consent of support from a person who holds a certain position in an organisation, he must make sure that in his EAs he does not misrepresent that he has the support of the organisation. He must ensure that his EAs do not give any misleading information that he has the support of the organisation as opposed to the person who holds the position in the organisation. When he has the support of an organisation, he must ensure that his EAs do not represent or give a misleading impression that he has the support of all the members of that organisation, unless the decision of that organisation in giving him support was made at a meeting of all its members present and voting.

18.6 Candidates should note that the Home Affairs Department has its own guidelines for Mutual Aid Committees and their office bearers in respect of their giving consent of support to candidates. A copy of such guidelines can be found at **Appendix O**.

18.7 Consent can be given to two or more candidates or two or more lists of candidate(s) of a GC, even if they are competing in the same constituency, although that may cause confusion. A consent given can also be revoked. In case of a revocation, in order to avoid dispute, it is advisable for the person or organisation who has revoked the consent to send a notice or copy of the revocation to the candidate concerned and to the RO for his constituency.

18.8 Once a consent has been revoked, the candidate concerned should be careful to cease immediately using any EA which contains the support of the person or organisation who has made the revocation. The costs incurred for the production of EAs bearing such support which have been used before revocation should still be regarded as the candidate's election expenses and be declared in the return and declaration of election expenses and donations.

18.9 On the question of whether expenditure incurred by an EA will need to be borne by candidate A if candidate A's name or photograph appears in the EA of candidate B to indicate support for candidate B, this would depend on whether the publicity material in question has explicitly or implicitly promoted the election of candidate A. There may be 2 different scenarios in such cases:

Scenario A

If the appearance of candidate A in candidate B's EA is solely to indicate support for candidate B but not to promote the election of candidate A, the EA should not be treated as a joint EA. The election expenses incurred should be counted as candidate B's election expenses only, but not as candidate A's. Candidate B has to obtain the prior written consent of support from candidate A before using candidate A's names or photographs in his EAs [s 27 of the ECICO].

Scenario B

If candidate B wishes to publish the EAs for promoting his candidature and that of candidate A as well, he must obtain prior written authorisation by candidate A as his election expense agent and the expenses so incurred will have to be borne by the

candidates A and B in equal or unequal shares as their respective election expenses, depending on the size of the portion advertising each.

18.10 It is not uncommon for candidates to put photographs in their EAs to show their past activities. However, it may be possible for electors to believe that those persons appearing in the photograph support a particular candidate when they receive such EAs. To minimize misunderstanding, for instance, if an EA carries a photograph of the candidate attending an activity with other attendees, a caption specifying the particular nature of the event could be added underneath the photograph in such a way that will not imply, or likely to cause electors to believe, that the candidate has the support of the other people appearing in the photograph. If the photograph is likely to cause electors to believe that the candidate has the support of the other people appearing in the photograph, it is advisable that prior written consent of support should be obtained by the candidate.

18.11 To avoid misleading the electors to believe that a candidate has obtained support from a certain person, organisation, government agency or department, which is not the case, a candidate should not attach any materials published by any such person, organisation, government agency or department together with his own EAs.

Form of Consent

18.12 The standard form “**Consent of Support**” is at **Appendix N**. It should be noted that the form is designed to cover a specific constituency in a particular election. A candidate who subsequently switches to another constituency should seek afresh the consent from the person or organisation concerned.

18.13 There are occasions (as allegations and complaints were received) requiring confirmation of the compliance of the law by a candidate. Therefore, every candidate is **required to deposit a copy** each of the **completed consent forms** with the relevant RO **before** the display, distribution or otherwise use of the relevant EA [s 102(10)(b) of the EAC (EP) (LC) Reg]. The relevant RO will then be in a position to answer such enquiries, thus saving the trouble and sometimes the embarrassment of the candidates. Candidates are also **required to notify** the relevant RO in writing of any **revocation** of consent. Such consent forms and notices of revocation (with the identity document numbers of the persons involved obliterated) will be made available for public inspection at the office of the relevant RO.

Penalty

18.14 It is an illegal conduct under the ECICO for a person to make false claim of support (ie a claim without **prior** written consent from the person or organisation concerned). For details of penalty and sanction, please refer to para. 17.4(b) and Part VII of Chapter 17.

CHAPTER 19

ATTENDANCE OF PUBLIC FUNCTIONS BY BOTH GOVERNMENT OFFICIALS AND CANDIDATES

PART I : GENERAL

19.1 This chapter mainly deals with the subject of government officials attending public functions which are also attended by candidates.

IMPORTANT :

“Candidate” includes a person who has publicly declared an intention to stand for election at any time before the close of nominations for the election, whether or not he has submitted a nomination form [s 2 of the ECICO]. It also includes a list of candidate(s) in a GC list to which the list voting system of proportional representation applies.

19.2 Although each person in Hong Kong may have his own political inclination, **certain categories of government officials**, namely Directorate Officers, Administrative Officers, Police Officers and Information Officers and those officers acting in these grades and ranks with a view to substantive appointment thereto (“government officials”), should not openly support any candidate or be seen to lend support to a candidate. They should not participate in any form of electioneering, including seeking election donations for any candidate. It would be grossly unfair to the other candidates if they were to support a candidate because of the vast resources available to them. It would be seen as an unjustifiable and unreasonable use of public resources and

would also defeat the fairness and equality aimed to be achieved by the limit of the election expenses with which every candidate is bound in law to comply.

19.3 There is no objection in principle to individual civil servants, other than the government officials listed in para. 19.2 above, supporting electioneering activities of a candidate provided that it does not give rise to any conflict of interest with their official duties, and that it does not involve the use of public resources or the wearing of any government uniform.

PART II : ATTENDANCE OF PUBLIC FUNCTIONS BY GOVERNMENT OFFICIALS

On the occasion of being invited

19.4 Government officials should exercise care in accepting invitations from persons or organisations to attend any public function that may also be attended by a candidate(s) (“the function”).

19.5 They should take such care when any person has publicly declared an intention to run for the election in respect of a particular constituency or when the nomination commences, whichever is the earlier, up to the end of the polling day.

19.6 Before deciding to attend the function, a government official should satisfy himself that:

- (a) by attending the function, he is performing an official duty normally required of the post he is currently holding; and

- (b) to his best knowledge, the organiser of the function has no intention whatsoever of making use of the function to promote or prejudice any candidate.

When attending

19.7 The EAC appeals to government officials not to have photographs taken with candidates at the function since such photographs, if published, may be seen as the official lending support to the candidate. A government official may do so, however, if the photograph taking:

- (a) arises from the need for him to perform his official duty at the function normally required of the post he is currently holding;
- (b) is a natural part of the function which, if the official declines to participate, would be seen as breaching the protocol appropriate to that function; or
- (c) is participated by all other candidates of the same constituency.

PART III : ATTENDANCE OF PUBLIC FUNCTIONS BY CANDIDATES

19.8 Similarly, the EAC appeals to all candidates who attend public functions not to have photographs taken with the officials, since such photographs, if published, may be seen as an unfair advantage over other candidates. A candidate may do so, however, if the photograph taking:

- (a) arises from the need for him to perform his role at the function as

requested by the function organiser;

- (b) is a natural part of the function which, if the candidate declines to participate, would be seen as breaching the protocol appropriate to that function; or
- (c) is participated by all other candidates of the same constituency.

PART IV : PRINCIPAL OFFICIALS

19.9 The terms “government officials” and “civil servants” used in the earlier parts of this chapter do not include Principal Officials appointed under the Accountability System. Principal Officials are political appointees and they may belong to or be affiliated with political organisations. Principal Officials have to comply with a “Code for Principal Officials under the Accountability System” published on 28 June 2002 in the Gazette [GN 3845].

19.10 Principal Officials may, subject to the guidelines below, participate in election-related activities.

19.11 Principal Officials are disqualified from being nominated as a candidate at an election of the CE, of the LegCo or of a DC.

19.12 As far as the LegCo Elections are concerned, Principal Officials should not use any public resources for any election-related activities. A Principal Official should ensure that when taking part in such activities, great care should be taken that there is no actual or potential conflict of interest with the business of the Government or his own official duties.

CHAPTER 20

COMPLAINTS PROCEDURE

PART I : GENERAL

20.1 This chapter deals with the procedure for making complaints relating to **any breach or non-compliance of the Guidelines and the EAC (EP) (LC) Reg or the spirit of them** which are for ensuring that elections are conducted honestly, fairly and openly.

20.2 A complaint against criminal, illegal or corrupt activities may be made direct to the relevant authorities such as the Police or the ICAC. The procedures for making and processing such a complaint will be handled by these authorities, and are not covered by this chapter.

PART II : TO WHOM A COMPLAINT MAY BE MADE

20.3 The EAC is an independent, apolitical and neutral body established by the EACO to deal with all matters concerning the conduct of elections including handling election-related complaints. The EAC may, if necessary, set up a **Complaints Committee** consisting of its 3 members and one or more judges of the District Court or High Court for the purpose of dealing with complaints.

20.4 Without limiting the right of a citizen to make a complaint to the Police or the ICAC or other authorities, a complaint for breach of or

non-compliance with the EAC (EP) (LC) Reg or Guidelines or relating to election matters can be made to one of the following bodies or persons:

- (a) the RO of the relevant constituency appointed by the EAC to deal with electoral arrangements;
- (b) the REO; or
- (c) the EAC or its Complaints Committee.

20.5 **Caution** : if the complaint is against the conduct, behaviour, or acts of any of the REO officers or the RO personally, it should be addressed to the EAC or its Complaints Committee and marked “CONFIDENTIAL” in order to ensure that only the Complaints Committee will receive it.

PART III : TIME AND PROCEDURE FOR MAKING COMPLAINT

20.6 The Guidelines deal with election-related activities, and any non-compliances, abuses and irregularities that can be redressed should be remedied as soon as practicably possible. It is **imperative** that **all complaints should be made as soon as possible**, for any delay in the making of complaint may result in remedial measures being useless or futile and necessary evidence being lost. No complaint received **later than 45 days** after the date of the relevant election will be entertained.

20.7 No specified or specific form is required for making a complaint. A complaint can be made either orally or in writing, either in Chinese or in English. A person who wishes to make an oral complaint can call the REO Complaints Hotline.

20.8 In each case, the complainant is required to identify himself and provide his identity document number, address, telephone number and other means of communication. A written complaint must be signed. Save where it relates to a matter of minor nature or which requires urgent action, an oral complaint received will be recorded in writing and the complainant will be required to sign the written record afterwards. All personal particulars of a complainant will be **treated in strict confidence.**

PART IV : COMPLAINTS INSIDE A POLLING STATION

20.9 If a person has any complaint about whatever happens inside a polling station, he should follow the following procedures:

- (a) he should direct his complaint to the PRO, the Deputy PRO or an Assistant PRO immediately.
- (b) if the matter is not resolved, or if the complainant still feels aggrieved or if his complaint is directed at the PRO, the Deputy PRO or an Assistant PRO, he should as soon as possible report the matter to the RO of the constituency of the polling station by using the telephone number appearing in the guide on procedures for complaint.
- (c) where the matter is still not resolved by the RO, the complainant should without any delay telephone the Complaints Hotline of the REO to report his complaint by giving a gist thereof. He should then try to obtain as much evidence as possible in order to substantiate his complaint. As he is not allowed to talk to or communicate with any elector inside the polling station, he may

need to go outside the polling station to obtain necessary evidence.

- (d) a member of the EAC or its Complaints Committee or an officer of the REO will handle the complaint as soon as practicable.

A copy of the guide on procedures for complaint at a polling station (together with telephone numbers of the relevant RO(s) and the REO Complaints Hotline) will be available for inspection inside each polling station.

20.10 The PRO or his Deputy or Assistant PRO must record any complaint mentioned in para. 20.9(a) and (b) and any other complaints and enquiries concerning an elector's data.

PART V : THE PROCESSING OF COMPLAINT

20.11 The PRO, ROs and the CEO are obliged under s 101 of the EAC (EP) (LC) Reg to report irregularities to the EAC or its Complaints Committee. By these guidelines, they are also required to report all complaints received by them to the EAC or its Complaints Committee. Except where a complaint is of minor nature or the RO has been delegated with the authority to deal with it, any complaint received by the RO or the REO will be forwarded to the EAC or its Complaints Committee with comments and all the relevant information relating to the complaint. When the EAC or its Complaints Committee receives a complaint, it may seek additional information and comments from the relevant RO or the REO, if necessary.

20.12 The EAC or its Complaints Committee, the RO or the REO (when they are so authorised by the EAC or its Complaints Committee), may

seek further information on the complaint from the complainant or may arrange interviews with the complainant in order to seek clarification or evidence. The complainant may be required to make a statutory declaration for the truth and correctness of his complaint or statement. If the further information required is not provided by the complainant or if he refuses to be interviewed or to make the statutory declaration, the EAC or its Complaints Committee, the RO or the REO may or may not take further action on the complaint.

20.13 All bona fide complaints will be processed and considered by the RO who has been delegated with the necessary authority or by the EAC or its Complaints Committee, as soon as reasonably practicable, taking into account the merits of the complaint with all the information and evidence gathered [see s 6(3) of the EACO].

20.14 Where a complaint is sustained, a decision will be made on the appropriate course to be taken, including one or more of the following:

- (a) take remedial measures against the matter complained of, such as the removal of EAs displayed in breach of the guidelines in that regard;
- (b) issue to the relevant person a warning to discontinue the activities complained of;
- (c) publish a public statement of reprimand or censure against the acts or omissions and the person or persons complained of [see various chapters in these Guidelines] after making a reasonable effort to contact the person or persons and giving him or them a reasonable opportunity to make representations [see s 6(4) of the EACO];

- (d) with or without comments, refer the matter to the ICAC for investigation and/or further action [s 5(e) of the EACO]; and
- (e) with or without comments, refer the matter to the Secretary for Justice or the Police for further action such as prosecution of the culprit [s 5(e) of the EACO].

20.15 The EAC or its Complaints Committee will also notify the complainant in writing of its decision, and if the decision is that the complaint is not sustained, it will also give reasons.

PART VI : ELECTORAL AFFAIRS COMMISSION'S REPORT ON COMPLAINTS

20.16 The EAC is required to report to the CE on any complaint made to it in connection with an election within 3 months of the conclusion of the election [s 8(1) and (2) of the EACO].

PART VII : OBLIGATIONS OF THE RETURNING OFFICER, THE PRESIDING OFFICER AND THE REGISTRATION AND ELECTORAL OFFICE

20.17 The RO(s), PRO(s) and the REO are required to report as soon as practicable to the EAC or its Complaints Committee (in writing or otherwise as circumstances may demand) on any complaints received by them and on any occurrence which they consider to be a material irregularity relating to an election, poll or count.

PART VIII : SANCTION FOR FALSE COMPLAINT

20.18 Any person who knowingly makes or causes to be made to an ICAC officer a false report of the commission of any offence or misleads such an officer by giving false information or by making false statements or accusations is guilty of an offence punishable by \$20,000 and imprisonment for 1 year under the ICAC Ordinance (Cap 204). A similar offence is committed where a false report is made or false information given to a police officer [s 64 of the Police Force Ordinance (Cap 232)]. If a person knowingly makes a false complaint of the commission of any offence to the EAC or its Complaints Committee knowing that the EAC or its Complaints Committee will refer or direct such complaint and information to the ICAC or the Police, the person concerned will similarly be guilty of the relevant offence. If a person knowingly and wilfully makes to the EAC or its Complaints Committee, the RO or the REO a statement false in a material particular and such a statement is in a statutory declaration, he commits an offence punishable by imprisonment for 2 years and a fine [s 36 of the Crimes Ordinance (Cap 200)].

**Legislative Council Election
Action Checklist for Candidates**

A. Major Steps to be Observed

1 week before and during Nomination Period 1. Obtain the Nomination Form from the Returning Officer (“RO”), any District Office (“DO”) of the Home Affairs Department or the Registration and Electoral Office (“REO”).

During Nomination Period 2. Except where the Chief Electoral Officer (“CEO”) authorises otherwise, personally deliver the following to the RO before expiry of the Nomination Period:

- (a) the duly completed Nomination Form; and
- (b) an election deposit in cash, cashier order or by cheque made payable to “The Government of the Hong Kong Special Administrative Region”.

In order to avoid the risk of invalidation of the nomination due to dishonoured cheques, candidates are strongly advised to submit the election deposit in cash or cashier order.

3. Obtain from the RO the following:
- (a) copies of the relevant legislation;
 - (b) an electoral boundary map of the relevant geographical constituency (“GC”) (for GC candidates only);
 - (c) relevant extracts from the Final Register of Electors, both gum labels and soft copies, on signing an Undertaking on the Use of Electoral Records;

- (d) information regarding display spots on government land or property that are available to candidates for display of election advertisements (“EAs”);
- (e) forms -
 - (i) Notice of Appointment of Election Agent
 - (ii) Notice of Authorisation of Person to Incur Election Expenses
 - (iii) Return and Declaration of Election Expenses and Donations by a GC List of Candidates [Applicable to a GC list of candidates only] or
Return and Declaration of Election Expenses and Donations [Applicable to Functional Constituency (“FC”) candidates only]
 - (iv) Notice of Appointment of Polling Agents
 - (v) Notice of Appointment of Counting Agents
 - (vi) Notice of Revocation of Appointment of Agent
 - (vii) Notice of Revocation of Authorisation to Incur Election Expenses
 - (viii) Notice of Withdrawal of Candidature
 - (ix) Declaration of Election Advertisements
 - (x) Corrective Declaration of Election Advertisements
 - (xi) Notification of Decision on Electioneering Activities

- (xii) Consent of Support
 - (xiii) Permission for Display/Distribution of Election Advertisements or Electioneering Activities at Private Premises
 - (xiv) Standard Receipt for Donations
 - (xv) Declaration of Secrecy
 - (xvi) Return of Election Deposit
 - (xvii) Advance Return of Donations
 - (xviii) Notice of Posting of Election Mail
 - (xix) Declaration for Posting of Election Mail
 - (xx) Notification of the Intention to hold a Public Meeting/Procession; and
- (f) notes on the preparation of a brief introduction for inclusion in the official leaflet.
4. Lodge with the RO a Notice of Withdrawal of Candidature if the candidate wishes to withdraw his candidature.
- Any time before, during or after handing in Nomination Form
5. (a) Except for the categories exempted, assign a serial number to all copies of each type of EAs intended for display, distribution or otherwise use.
- (b) Submit to the RO (or CEO if RO has not yet been appointed) a Declaration of Election Advertisements **before** display, distribution or otherwise use of EAs. Candidates may submit as many declarations as required from time to time.

- (c) Ensure that all printed EAs contain the name and address of the printer, date of printing and the number of copies printed.
- (d) Submit to the RO (or CEO if RO has not yet been appointed) 2 copies of each type of EAs **before** display, distribution or otherwise use.
- (e) Submit to the RO (or CEO if RO has not yet been appointed), **before** display, distribution or otherwise use of EAs at private premises, a copy of Permission for Display/Distribution of Election Advertisements or Electioneering Activities at Private Premises.
- (f) Submit to the RO (or CEO if RO has not yet been appointed), **before** display, distribution or otherwise use of EAs, a copy of Consent of Support, where necessary.

Any time after handing in Nomination Form

- 6. Lodge with the RO a Notice of Appointment of Election Agent.
- 7. Lodge with the RO Notices of Authorisation of Persons to Incur Election Expenses.
[For GC list of candidates, Return and Declaration of Election Expenses Already Incurred and Cross-Authorisation of Candidates on a List of Candidates in a GC Election is applicable]
- 8. Submit to the CEO an Advance Return of Donations when a donation is received.

Any time after handing in Nomination Form, but before expiry of Nomination Period

- 9. (a) Lodge with the RO 5 identical colour photographs in specified size of the candidate taken not longer than 6 months ago.
- (b) Lodge with the RO an introductory message for publication in the official introductory leaflet by completion of the specified grid paper.

- | | |
|---|--|
| Any time after handing in Nomination Form, but not later than 7 days before polling day | 10. Lodge with the RO Notices of Appointment of Polling Agents. |
| | 11. Lodge with the RO Notices of Appointment of Counting Agents. |
| Within 3 days after close of nomination | 12. Attend the briefing for candidates and collect from the RO the following:

(a) location and layout plans of the polling/counting station; and

(b) name badges for the candidate and his agents. |
| | 13. Attend meetings held by the RO to determine the candidate numbers by drawing of lots and to allocate display spots for display of EAs. |
| | 14. Obtain the permission/licence from the relevant authority for display at display spots. |
| Within 10 days after expiry of Nomination Period | 15. Receive from the RO information about the election agents appointed by other candidates of the same constituency. |
| Within 14 days after expiry of Nomination Period | 16. Receive from the RO the notice on other validly nominated candidates of the same constituency. |
| 2 working days before posting postage-free election mail | 17. Give notice of the free postings of election mail by using the Notice of Posting of Election Mail, and present two unsealed specimen packets to the relevant Manager (Retail Business) for inspection and retention. |
| Not later than 14 working days before polling day | 18. Post postage-free election mail and present to the Post Office a Declaration for Posting of Election Mail. |
| Not later than 7 days before polling day | 19. Receive from the RO information regarding the delineation of no canvassing zone and no staying zone for the polling station. |

- | | |
|---|---|
| Not later than 12 noon before polling day | 20. Lodge with the RO Corrective Declarations of Election Advertisements, if any. |
| Before entering polling/counting station | 21. Complete the Declarations of Secrecy (to be made by all candidates, their election agents, polling agents and counting agents). |
| Any time before polling day | 22. Lodge with the RO Notices of Revocation of Appointment of Agent, if any. |
| On polling day | 23. Attend the poll and the count if the candidate so wishes, bringing along the Declaration of Secrecy. |
| | 24. Candidates or their election agents personally deliver Notices of Appointment of Polling Agents and Notices of Revocation of Appointment of Agent to the relevant Presiding Officer (“PRO”), if not yet submitted to the RO under paras. 10 and 22 respectively. |
| | 25. Candidates or their election agents personally deliver Notices of Appointment of Counting Agents and Notices of Revocation of Appointment of Agent to the relevant PRO or the RO, if not yet submitted to the RO under paras. 11 and 22 respectively. |
| Within 7 days after polling day | 26. Remove all EAs on display. |
| Not later than 60 days of the gazettal of the election result (If uncontested, the election result will be gazetted in the Notice of Nominations) | 27. (a) Lodge with the CEO a Return and Declaration of Election Expenses and Donations signed by the candidate with original receipted vouchers and duplicate donation receipts.
[For GC list of candidates, Return and Declaration of Election Expenses and Donations by a GC List of Candidates is applicable] |

- (b) An uncontested candidate who is returned as a Member should lodge with the CEO a Return and Declaration of Election Expenses and Donations signed by the candidate with original receipted vouchers and duplicate donation receipts not later than 60 days after the gazettal of the Notice of Nominations.

B. Handling and Declaring Election Expenses

Records Keeping

Before and After Nomination

- 1. Record all expenses spent and all donations received.
- 2. Keep vouchers/receipts for expenses \$100 or above.
- 3. Issue receipt for any donation of more than \$1,000. (The candidate/list of candidates should use the standard receipt provided by REO.)
- 4. Keep copies of all Declarations of Election Advertisements and copies of the EAs lodged with the RO.

Appointment of Election Agents/Election Expense Agents

- 5. Each candidate/list of candidates can only appoint one election agent. He has the authority to do everything a candidate is authorised to do for the purposes of the election except:
 - (a) anything a candidate is required to do in relation to his nomination;
 - (b) to withdraw the candidate's candidature;
 - (c) to incur election expenses unless he has been so authorised by the candidate; and
 - (d) to authorise a person as an election expense agent to incur election expenses.

6. Each candidate/list of candidates can appoint one or more persons authorised to incur election expenses on his/their behalf, ie the election expense agents, by completing the Notice of Authorisation of Persons to Incur Election Expenses. A candidate/list of candidates **may** also authorise his/their election agent to incur election expenses for him/them. These agents may incur expenses only after the candidate/list of candidates has/have authorised them to do so. (After the formation of a GC list of candidates, each candidate on the list must also obtain the cross-authorisation from each other before they can incur any election expenses.)

***Lodgement of
Authorisation and
Declaration to
appropriate authority***

7. Lodge with the RO the Notice of Appointment of Election Agent at any time after handing in Nomination Form.
8. The candidate/list of candidates must serve a notice of the authorisation for persons to incur election expenses on the RO (or CEO if the RO has not yet been appointed). It is important to note that the authorisation is not effective until it has been received by the RO or CEO (if the RO has not yet been appointed).
9. 2 copies of each type of EAs must be deposited with the RO (or CEO if the RO has not yet been appointed) together with a Declaration of Election Advertisements **before** display, distribution or otherwise use.

***Submission of Return
and Declaration of
Election Expenses and
Donations***

***Not later than 60 days after the Gazettal of
Election Result***

10. The completed return and declaration should be submitted together with all supporting vouchers and receipts.
11. The completed form should include all donations received by the candidate/list of candidates and all election expenses incurred by him/them or by

his/their election expense agents, and also the removal cost for his/their EAs by government departments, if he/they has/have not removed all his/their EAs by the deadline specified by the EAC. ***Candidates/list of candidates are required to submit their returns even if no election expenses have been incurred.***

12. A candidate/list of candidates must make declaration before a Commissioner for Oaths or a Justice of the Peace or a solicitor holding a practising certificate.
13. (a) A candidate/list of candidates must lodge his/their completed return with the CEO at Room 1507, 15/F, Guardian House, 32 Oi Kwan Road, Wan Chai by the deadline (ie not later than 60 days after the gazettal of election result).

(b) For an uncontested candidate/list of candidates who is returned as a Member, he/they must lodge his/their completed election return not later than 60 days after the gazettal of the Notice of Nominations.
14. If a candidate/list of candidates fails to lodge the return before the deadline, he/they can apply to the Court for an order allowing him/them to lodge the return with the CEO within such further period as the Court specifies.
15. If a candidate/list of candidates wishes to change any information in his/their election return before the deadline, he/they may lodge with the CEO a supplement to his/their return before the deadline.
16. If a candidate/list of candidates wishes to change any information in the election return after the deadline, he/they must apply to the Court for an order enabling him/them to correct any error or false statement in his/their return or in any document accompanying his/their return.

The Functional Constituencies and their Electors

<u>Column 1</u> <u>Constituency</u>	<u>Column 2</u> <u>Electors</u>
1. Heung Yee Kuk functional constituency	Chairman and Vice-Chairmen of the Heung Yee Kuk and Ex Officio, Special and Co-opted Councillors of the Full Council of the Kuk.
2. Agriculture and fisheries functional constituency	(1) Corporate members of each of the following bodies: <ul style="list-style-type: none">(a) Federation of Vegetable Marketing Co-operative Societies, Limited;(b) Federation of Pig Raising Co-operative Societies of Hong Kong, Kowloon and New Territories, Ltd.;(c) The Joint Association of Hong Kong Fishermen;(d) Federation of Hong Kong Aquaculture Associations;(e) The Federation of Fishermen's Co-operative Societies of Shau Kei Wan District, Limited;(f) The Federation of Fishermen's Co-operative Societies of Tai Po District, N.T., Limited;(g) The Federation of Fishermen's Co-operative Societies of Sai Kung District, Limited;(h) The Federation of Fishermen's Co-operative Societies of Southern District, Limited.
	(2) The Aberdeen Fishermen Friendship Association.
	(3) The Ap Lei Chau Fishermen's Credit Co-operative Society, Unlimited.
	(4) The Castle Peak Fishermen's Credit Co-operative Society, Unlimited.
	(5) The Castle Peak Mechanized Trawler Fishermen's Credit Co-operative Society, Unlimited.
	(6) Cheung Chau Fisheries Joint Association.
	(7) Cheung Chau Fishermen's Welfare Promotion Association.
	(8) The Fanling Kwun Ti Village Farmers' Irrigation Co-operative Society, Ltd.
	(9) Fish Farming and Stuff Association.
	(10) Fisherman's Association of Po Toi Island.
	(11) Fishery Development Association (Hong Kong) Limited.
	(12) Fraternal Association of The Floating Population of Hong Kong.
	(13) The Guild of Graziers.
	(14) Hang Hau Grazier Association.
	(15) Hong Kong and Kowloon Fishermen Association Ltd.
	(16) Hong Kong & Kowloon Floating Fishermen Welfare Promotion Association.

Column 1
Constituency

Column 2
Electors

- (17) The Hong Kong Fisheries Development Association.
- (18) Hong Kong Fishermen's Association.
- (19) Hong Kong Fishing Vessel Owners Association, Ltd.
- (20) Hong Kong Florists Association.
- (21) Hong Kong Graziers Union.
- (22) The Hong Kong Liner & Gillnetting Fisherman Association.
- (23) Hong Kong Livestock Industry Association.
- (24) Hong Kong N.T. Fish Culture Association.
- (25) Hong Kong N.T. Poultry - Culture (Geese & Ducks) Mutual Association.
- (26) Hong Kong Netting, Cultivation and Fisherman Association.
- (27) Hong Kong New Territories Boat People Association.
- (28) Hong Kong Off-shore Fishermen's Association.
- (29) Hong Kong Pigfarm Association Limited.
- (30) The Lam Ti Agricultural Credit Co-operative Society, Limited.
- (31) Lamma Island Lo Dik Wan Aquaculture Association.
- (32) Lau Fau Shan Oyster Industry Association, New Territories.
- (33) Ma Wan Fisheries Rights Association Ltd.
- (34) The Mui Wo Agricultural Products Marketing & Credit Co-operative Society, Ltd.
- (35) Mui Wo Fishermen Fraternity Society.
- (36) N.T. Oyster and Aquatic Products United Association.
- (37) The New Territories Chicken Breeders Association, Ltd.
- (38) The New Territories Fishermen Fraternity Association Ltd.
- (39) New Territories Florist Association, Ltd.
- (40) North District Florists Association.
- (41) Outlying Islands Mariculture Association (Cheung Chau).
- (42) Peng Chau Fishermen Association Ltd.
- (43) Quality Broiler Development Association.
- (44) Sai Kung Fishermen Association Limited.
- (45) Sai Kung (North) Sham Wan Marine Fish Culture Business Association.
- (46) Sai Kung Po Toi O Fish Culture Business Association.
- (47) Sai Kung Tai Tau Chau Fish Culture Business Association.
- (48) Sai Kung Tai Wu Kok Fishermen's Association.
- (49) Sha Tau Kok Marine Fish Culture Association.
- (50) The Sha Tau Kok Small Long Liner and Gill Net Fishermen's Credit Co-operative Society, Unlimited.
- (51) The Shan Tong Vegetable Marketing Co-operative Society, Ltd.

Column 1
Constituency

Column 2
Electors

- (52) Shatin Ah Kung Kok Fishermen Welfare Association.
- (53) Shatin Florists Association.
- (54) The Shau Kei Wan Deep Sea Capture Fishermen's Credit Co-operative Society, Unlimited.
- (55) Shau Kei Wan Fishermen Friendship Association.
- (56) The Shau Kei Wan Pair Trawler Fishermen's Credit Co-operative Society, Unlimited.
- (57) The Shau Kei Wan Trawler Fishermen's Credit Co-operative Society, Unlimited.
- (58) The Sheung Shui Ngai Yuen Sun Tsuen Pig Raising Co-operative Society, Ltd.
- (59) Tai O Fishermen (Coastal Fishery) Association.
- (60) The Tai O Sha Chai Min Fishermen's Credit Co-operative Society, Unlimited.
- (61) The Tai Po Fishermen's Credit Co-operative Society, Unlimited.
- (62) Tai Po Florists and Horticulturists Association.
- (63) The Tai Po Ma Wo Village Pig Raising Co-operative Society, Ltd.
- (64) The Tai Po Purse Seiner and Small Long Liner Fishermen's Credit Co-operative Society, Unlimited.
- (65) The Tsing Lung Tau Hand Liner Fishermen's Credit Co-operative Society, Unlimited.
- (66) The Tsuen Wan Fishermen's Credit Co-operative Society, Unlimited.
- (67) The Tuen Mun Mechanized Fishing Boat Fishermen's Credit Co-operative Society, Unlimited.
- (68) Tuen Mun Agricultural Association.
- (69) Tung Lung Chau Mariculture Association.
- (70) The World Poultry Science Association, Hong Kong Branch.
- (71) The Wu Kau Tang Village Agricultural Credit Co-operative Society, Limited.
- (72) The Yuen Long Agriculture Productivity Association.
- (73) Yung Shue Au Marine Fish Culture Business Association.
- (74) 青衣水陸居民聯誼會.
- (75) 荃灣葵青居民聯會 (漁民組) .
- (76) 荃灣葵青漁民會.
- (77) The Shau Kei Wan Stern Trawler Fishermen's Credit Cooperative Society, Unlimited.
- (78) Hong Kong Organic Farming Association Limited.
- (79) N. T. North District Fishermen's Association.
- (80) Tai Po Off Shore Fishermen's Association.
- (81) Aberdeen Fisherwomen Association.

<u>Column 1</u> <u>Constituency</u>	<u>Column 2</u> <u>Electors</u>
3. Insurance functional constituency	Bodies that are insurers authorised or deemed to be authorised under the Insurance Companies Ordinance (Cap 41).
4. Transport functional constituency	(1) VINCI Park Services Hong Kong Limited. (2) Airport Authority Hong Kong. (3) Articulated & Commercial Vehicle's Instructors Union. (4) The Association of N.T. Radio Taxicabs Ltd. (5) Autotoll Limited. (6) The Chartered Institute of Logistics and Transport in Hong Kong. (7) China Merchants Shipping & Enterprises Co. Ltd. (8) China Tollways Ltd. (9) Chu Kong Shipping Enterprises (Holdings) Co. Ltd. (10) Chuen Kee Ferry Ltd. (11) Chuen Lee Radio Taxis Association Ltd. (12) Citybus Ltd. (13) Coral Sea Ferry Service Co., Ltd. (14) COSCO-HIT Terminals (Hong Kong) Limited. (15) CTOD Association Company Ltd. (16) Turbojet Ferry Services (Guangzhou) Limited. (17) Discovery Bay Transportation Services Ltd. (18) Driving Instructors Merchant Association Ltd. (19) Eastern Ferry Co. (20) Expert Fortune Ltd. (21) Far East Hydrofoil Co. Ltd. (22) Fat Kee Stevedores Ltd. (23) The Fraternity Association of N.T. Taxi Merchants. (24) Fraternity Taxi Owners Association. (25) G.M.B. Maxicab Operators General Association Ltd. (26) The Goods Vehicle Fleet Owners Association Ltd. (27) Happy Taxi Operator's Association Ltd. (28) HKS Parking Limited. (29) Hoi Kong Container Services Co. Ltd. (30) Hon Wah Public Light Bus Association Ltd. (31) Hong Kong Air Cargo Terminals Limited. (32) Hong Kong & Kowloon Ferry Ltd. (33) Hong Kong & Kowloon Goods Vehicle Omnibuses and Minibuses Instructors' Association Ltd. (34) Hong Kong & Kowloon Motor Boats and Tug Boats Association Ltd. (35) Hong Kong & Kowloon Radio Car Owners Association Ltd. (36) Hong Kong and Kowloon Rich Radio Car Service Centre Association Ltd. (37) Hong Kong & Kowloon Taxi Companies Association Limited.

Column 1
Constituency

Column 2
Electors

- (38) HongKong Association of Freight Forwarding and Logistics Limited.
- (39) Hong Kong Automobile Association.
- (40) The Hong Kong Cargo-Vessel Traders' Association Ltd.
- (41) Hong Kong Commercial Vehicle Driving Instructors Association.
- (42) Hong Kong CFS and Logistics Association Limited.
- (43) Hong Kong Container Tractor Owner Association Ltd.
- (44) Hong Kong Driving Instruction Club Ltd.
- (45) Hong Kong Guangdong Transportation Association Ltd.
- (46) The Hong Kong Institute of Marine Technology.
- (47) Hong Kong, Kowloon & NT Public & Maxicab Light Bus Merchants' United Association.
- (48) Hong Kong Kowloon Taxi & Lorry Owners Association Ltd.
- (49) The Hong Kong Liner Shipping Association.
- (50) Hong Kong Marine Contractors Association.
- (51) Hong Kong Motor Car Driving Instructors Association Ltd.
- (52) Hong Kong Pilots Association Ltd.
- (53) Hong Kong Public & Maxicab Light Bus United Associations.
- (54) Hong Kong Public Cargo Working Areas Traders Association Ltd.
- (55) Hong Kong Scheduled (GMB) Licensee Association.
- (56) The Hong Kong School of Motoring Ltd.
- (57) The Hong Kong Sea Transport Association Ltd.
- (58) The Hong Kong Shipowners Association Ltd.
- (59) Hong Kong Shipping Circles Association Ltd.
- (60) Hong Kong Shipping Industry Institute.
- (61) Hong Kong Shipping Staff Association.
- (62) Hong Kong Society of Articulated Vehicle Driving Instructors Ltd.
- (63) The Hong Kong Stevedores Employers' Association.
- (64) Hong Kong Tele-call Taxi Association.
- (65) Hong Kong Tramways, Limited.
- (66) Hong Kong Transportation Warehouse Wharf Club.
- (67) Hong Kong Tunnels and Highways Management Company Limited.
- (68) The Hongkong & Yaumati Ferry Co., Ltd.
- (69) Hongkong International Terminals Ltd.
- (70) Institute of Advanced Motorists (Hong Kong) Limited.
- (71) The Institute of Seatransport.
- (72) Institute of Transport Administration (China - Hong Kong Centre).
- (73) Kowloon Fung Wong Public Light Bus Merchants & Workers' Association Ltd.

Column 1
Constituency

Column 2
Electors

- (74) Kowloon Motor Bus Company (1933) Ltd.
- (75) Kowloon Motor Driving Instructors' Association Ltd.
- (76) The Kowloon PLB Chiu Chow Traders & Workers Friendly Association.
- (77) The Kowloon Taxi Owners Association Ltd.
- (78) Kowloon Truck Merchants Association Ltd.
- (79) Kowloon-Canton Railway Corporation.
- (80) Kwik Park Limited.
- (81) Lam Tin Wai Hoi Public Light Bus Merchants Association Ltd.
- (82) Lantau Taxi Association.
- (83) Lei Yue Mun Ko Chiu Road Public Light Bus Merchants Association Ltd.
- (84) Lok Ma Chau China - Hong Kong Freight Association.
- (85) Long Win Bus Company Limited.
- (86) Lung Cheung Public Light Bus Welfare Advancement Association Ltd.
- (87) Mack & Co. Carpark Management Limited.
- (88) Marine Excursion Association Limited.
- (89) Maritime Affairs Research Association Ltd.
- (90) MTR Corporation Limited.
- (91) Merchant Navy Officers' Guild - Hong Kong.
- (92) Metropark Limited.
- (93) Mid-stream Holdings (HK) Limited.
- (94) Mixer Truck Drivers Association.
- (95) Modern Terminals Ltd.
- (96) N.T. PLB Owners Association.
- (97) N.T. San Tin PLB (17) Owners Association.
- (98) N.T. Taxi Merchants Association Ltd.
- (99) N.T. Taxi Owners & Drivers Fraternal Association.
- (100) N.T. Taxi Radio Service General Association.
- (101) N.W. Area Taxi Drivers & Operators Association.
- (102) New Hong Kong Tunnel Co., Ltd.
- (103) New Lantao Bus Co., (1973) Ltd.
- (104) New Territories Cargo Transport Association Ltd.
- (105) New World First Bus Services Limited.
- (106) North District Taxi Merchants Association.
- (107) Organisation of Hong Kong Drivers.
- (108) Ken On Concrete Co. Ltd. Concrete Lorry Owner-Drivers Association.
- (109) Peak Tramways Co., Ltd.
- (110) Pioneer Concrete Owners Drivers Association.
- (111) Private Hire Car for Young Children Association Ltd.
- (112) Public and Private Light Buses Driving Instructors' Society.
- (113) The Public Cargo Area Trade Association.
- (114) Public Light Bus General Association.

Column 1
Constituency

Column 2
Electors

- (115) The Public Omnibus Operators Association Ltd.
- (116) Public Vehicle Merchants Fraternity Association.
- (117) Quadripartite Taxi Service Association Ltd.
- (118) Rambo Taxi Owners Association Ltd.
- (119) River Trade Terminal Co. Ltd.
- (120) Route 3 (CPS) Company Limited.
- (121) Sai Kung Public Light Bus Drivers and Owners Association.
- (122) Sai Kung Taxi Operators Association Ltd.
- (123) Salvage Association (Hong Kong Office).
- (124) CSX World Terminals Hong Kong Limited.
- (125) Serco Group (HK) Limited.
- (126) The "Star" Ferry Co., Ltd.
- (127) Sun Hing Taxi Radio Association.
- (128) Tang's Taxi Companies Association Ltd.
- (129) Tate's Cairn Tunnel Co., Ltd.
- (130) Taxi Associations Federation.
- (131) Taxi Dealers & Owners Association Ltd.
- (132) Taxi Drivers & Operators Association Ltd.
- (133) The Taxi Operators Association Ltd.
- (134) Taxicom Vehicle Owners Association Ltd.
- (135) Tsing Ma Management Limited.
- (136) Tsuen Wan PLB Commercial Association Ltd.
- (137) Tuen Mun PLB Association.
- (138) Tung Yee Shipbuilding and Repairing Merchants General Association Limited.
- (139) United Association of Public Lightbus Hong Kong.
- (140) United Friendship Taxi Owners & Drivers Association Ltd.
- (141) United Radio Taxi & Goods Vehicle Association Ltd.
- (142) Urban Taxi Drivers Association Joint Committee Co. Ltd.
- (143) Wai Fat Taxi Owners Association Ltd.
- (144) Wai Yik H.K. & Kowloon and New Territories Taxi Owners Association.
- (145) West Coast International (Parking) Limited.
- (146) Western Harbour Tunnel Co. Ltd.
- (147) Wilson Parking (Hong Kong) Limited.
- (148) Wing Lee Radio Car Traders Association Ltd.
- (149) Wing Tai Car Owners & Drivers Association Ltd.
- (150) Wu Gang Shipping Co. Ltd.
- (151) Xiamen United Enterprises (H.K.) Ltd.
- (152) Yik Sun Radiocabs Operators Association Ltd.
- (153) Young Children School Mini-Buses Operators Association Ltd.
- (154) Yuen Long Tai Po PLB Merchants Association Ltd.
- (155) Rights of Taxi Owners and Drivers Association Limited.

Column 1
Constituency

Column 2
Electors

- (156) New World First Ferry Services Limited.
- (157) New World First Ferry Services (Macau) Limited.
- (158) Hong Kong Container Drayage Services Association Limited.
- (159) Hong Kong Kowloon & N.T. Grab-Mounted Lorries Association Limited.
- (160) Hong Kong Waste Disposal Industry Association.
- (161) HK Public-light Bus Owner & Driver Association.
- (162) Container Truck Drivers Union.
- (163) The Concrete Producers Association of Hong Kong Limited.
- (164) Hongkong Guangdong Boundary Crossing Bus Association Limited.
- (165) Tsui Wah Ferry Service Company Limited.
- (166) Quality Driver Training Centre Limited.
- (167) Public and Private Commercial Driving Instructors' Society.
- (168) Shun Tak-China Travel Ship Management Limited.
- (169) Cruise Ferries (HK) Limited.
- (170) Asia Airfreight Terminal Company Limited.
- (171) The Hong Kong Joint Branch of The Royal Institution of Naval Architects and The Institute of Marine Engineering, Science and Technology.
- (172) The Hongkong Salvage & Towage Company Limited.
- (173) The Institute of Chartered Shipbrokers, Hong Kong Branch.
- (174) Hongkong United Dockyards Limited.
- (175) Guangdong and Hong Kong Feeder Association Limited.
- (176) Hong Kong Right Hand Drive Motors Association Limited.
- (177) The Institute of the Motor Industry Hong Kong.
- (178) Hong Kong Vehicle Repair Merchants Association Limited.
- (179) Environmental Vehicle Repairers Association Limited.
- (180) The Hong Kong Taxi and Public Light Bus Association Limited.
- (181) Park Island Transport Company Limited.
- (182) Discovery Bay Road Tunnel Company Limited.
- (183) International Association of Transport Officers.
- (184) Helicopters Hong Kong Limited.
- (185) Hong Kong (Cross Border) Transportation Drivers' Association.
- (186) Hong Kong Logistics Association Limited.
- (187) Hong Kong Container Depot and Repairer Association Limited.
- (188) New World Parking Management Limited.
- (189) The Nautical Institute-Hong Kong Branch.

<u>Column 1</u> <u>Constituency</u>	<u>Column 2</u> <u>Electors</u>
	(190) The Hong Kong Union of Light Van Employees. (191) Worldwide Flight Services, Inc.
5. Education functional constituency	(1) Full-time academic staff engaged in teaching or research and administrative staff of equivalent rank in - (a) institutions of higher education funded through the University Grants Committee; (b) approved post secondary colleges registered under the Post Secondary Colleges Ordinance (Cap 320); (c) technical colleges established under the Vocational Training Council Ordinance (Cap 1130); (d) The Hong Kong Academy for Performing Arts; (e) The Open University of Hong Kong. (2) Full-time academic staff engaged in teaching or research and administrative staff of equivalent rank in - (a) School of Continuing and Professional Education of the City University of Hong Kong; (b) School of Continuing Education of the Hong Kong Baptist University; (c) Lingnan Institute of Further Education of the Lingnan University; (d) School of Continuing Studies of The Chinese University of Hong Kong; (e) Division of Continuing Professional Education of The Hong Kong Institute of Education; (f) School of Professional Education and Executive Development of The Hong Kong Polytechnic University; (g) HKUST College of Lifelong Learning Limited; (h) HKU School of Professional and Continuing Education. (3) Members of each of the following bodies - (a) Council of the University of Hong Kong; (b) Council of The Chinese University of Hong Kong; (c) Council of The Hong Kong University of Science and Technology; (d) Council of the City University of Hong Kong; (e) Council of The Hong Kong Polytechnic University; (f) Council of The Hong Kong Academy for Performing Arts; (g) Council of The Open University of Hong Kong; (h) Council of the Vocational Training Council; (i) Council of The Hong Kong Institute of Education; (j) Council of the Hong Kong Baptist University; (k) Council of the Lingnan University; (l) Board of Governors of the Hong Kong Shue Yan College;

<u>Column 1</u> <u>Constituency</u>	<u>Column 2</u> <u>Electors</u>
	<p>(m) Board of Governors of the Caritas Francis Hsu College.</p> <p>(4) Registered teachers registered under the Education Ordinance (Cap 279).</p> <p>(5) Permitted teachers engaged in full-time employment in schools registered or provisionally registered under the Education Ordinance (Cap 279).</p> <p>(6) Teachers and principals of schools entirely maintained and controlled by the Government.</p> <p>(7) Persons whose principal or only employment is that of full-time teaching with the following institutions -</p> <ul style="list-style-type: none">(a) technical institutes, industrial training centres or skills centres established under the Vocational Training Council Ordinance (Cap 1130);(b) industrial training centres established under the Industrial Training (Construction Industry) Ordinance (Cap 317);(c) industrial training centres established under the Industrial Training (Clothing Industry) Ordinance (Cap 318);(d) Hong Chi Association - Hong Chi Pinehill Advanced Training Centre;(e) Caritas Lok Mo Skills Centre of Caritas-Hong Kong incorporated under the Caritas-Hong Kong Incorporation Ordinance (Cap 1092). <p>(8) Registered managers of schools registered under the Education Ordinance (Cap 279).</p>
6. Legal functional constituency	<p>(1) Members of The Law Society of Hong Kong entitled to vote at general meetings of the Society.</p> <p>(2) Members of the Hong Kong Bar Association entitled to vote at general meetings of the Association.</p> <p>(3) Legal officers within the meaning of the Legal Officers Ordinance (Cap 87).</p> <p>(4) Persons appointed under section 3 of the Legal Aid Ordinance (Cap 91).</p> <p>(5) Persons deemed to be legal officers for the purpose of the Legal Officers Ordinance (Cap 87) by section 75(3) of the Bankruptcy Ordinance (Cap 6) or section 3(3) of the Director of Intellectual Property (Establishment) Ordinance (Cap 412).</p> <p>(6) The Legal Adviser of the Legislative Council Secretariat and his or her assistants who are in the full-time employment of The Legislative Council Commission and are barristers or solicitors as defined in the Legal Practitioners Ordinance (Cap 159).</p>

<u>Column 1</u> <u>Constituency</u>	<u>Column 2</u> <u>Electors</u>
7. Accountancy functional constituency	Professional accountants registered under the Professional Accountants Ordinance (Cap 50).
8. Medical functional constituency	(1) Medical practitioners registered or deemed to be registered under the Medical Registration Ordinance (Cap 161). (2) Dentists registered, deemed to be registered or exempt from registration under the Dentists Registration Ordinance (Cap 156).
9. Health services functional constituency	(1) Chiropractors registered under the Chiropractors Registration Ordinance (Cap 428). (2) Nurses registered or enrolled or deemed to be registered or enrolled under the Nurses Registration Ordinance (Cap 164). (3) Midwives registered or deemed to be registered under the Midwives Registration Ordinance (Cap 162). (4) Pharmacists registered under the Pharmacy and Poisons Ordinance (Cap 138). (5) Medical laboratory technologists registered under the Medical Laboratory Technologists (Registration and Disciplinary Procedure) Regulations (Cap 359 sub. leg. A). (6) Radiographers registered under the Radiographers (Registration and Disciplinary Procedure) Regulation (Cap 359 sub. leg. H). (7) Physiotherapists registered under the Physiotherapists (Registration and Disciplinary Procedure) Regulation (Cap 359 sub. leg. J). (8) Occupational therapists registered under the Occupational Therapists (Registration and Disciplinary Procedure) Regulations (Cap 359 sub. leg. B). (9) Optometrists registered under the Optometrists (Registration and Disciplinary Procedure) Regulation (Cap 359 sub. leg. F). (10) Dental hygienists enrolled under the Ancillary Dental Workers (Dental Hygienists) Regulations (Cap 156 sub. leg. B). (11) Audiologists, audiology technicians, chiropodists (also known as "podiatrists"), dental surgery assistants, dental technicians, dental technologists, dental therapists, dietitians, dispensers, mould laboratory technicians, orthoptists, clinical psychologists, educational psychologists, prosthetists, speech therapists and scientific officers (medical) who are in the service under the Government, or are employed in Hong Kong, at the

<u>Column 1</u> <u>Constituency</u>	<u>Column 2</u> <u>Electors</u>
	following institutions - (a) Public hospitals within the meaning of the Hospital Authority Ordinance (Cap 113); (b) Hospitals registered under the Hospitals, Nursing Homes and Maternity Homes Registration Ordinance (Cap 165); (c) Clinics maintained or controlled by the Government or The Chinese University of Hong Kong or by the University of Hong Kong; (d) services subvented by the Government.
10. Engineering functional constituency	(1) Professional engineers registered under the Engineers Registration Ordinance (Cap 409). (2) Members of the Hong Kong Institution of Engineers entitled to vote at general meetings of the Institution.
11. Architectural, surveying and planning functional constituency	(1) Architects registered under the Architects Registration Ordinance (Cap 408). (2) Members of The Hong Kong Institute of Architects entitled to vote at general meetings of the Institute. (3) Landscape architects registered under the Landscape Architects Registration Ordinance (Cap 516). (4) Members of The Hong Kong Institute of Landscape Architects entitled to vote at general meetings of the Institute. (5) Professional surveyors registered under the Surveyors Registration Ordinance (Cap 417). (6) Members of The Hong Kong Institute of Surveyors entitled to vote at general meetings of the Institute. (7) Professional planners registered under the Planners Registration Ordinance (Cap 418). (8) Members of The Hong Kong Institute of Planners entitled to vote at general meetings of the Institute.
12. Labour functional constituency	Bodies that are trade unions registered under the Trade Unions Ordinance (Cap 332) of which all the voting members are employees.
13. Social welfare functional constituency	Social workers registered under the Social Workers Registration Ordinance (Cap 505).
14. Real estate and construction functional constituency	(1) Members of The Real Estate Developers Association of Hong Kong entitled to vote at general meetings of the Association. (2) Members of The Hong Kong Construction Association, Limited entitled to vote at general meetings of the

<u>Column 1</u> <u>Constituency</u>	<u>Column 2</u> <u>Electors</u>
	Association.
	(3) Members of The Hong Kong E&M Contractors' Association Limited entitled to vote at general meetings of the Association.
15. Tourism functional constituency	Bodies that are: (1) travel industry members of the body known immediately before 1 April 2001 as the Hong Kong Tourist Association, entitled immediately before that date, under the constitution of that body in force immediately before that date, to vote at general meetings of the Association. (2) members of the Travel Industry Council of Hong Kong entitled to vote at general meetings of the Council. (3) members of the Hong Kong Board of Airline Representatives. (4) members of the Hong Kong Hotels Association entitled to vote at general meetings of the Association. (5) members of the Federation of Hong Kong Hotel Owners entitled to vote at general meetings of the Federation.
16. Commercial (first) functional constituency	Bodies that are members of The Hong Kong General Chamber of Commerce entitled to vote at general meetings of the Chamber.
17. Commercial (second) functional constituency	Members of The Chinese General Chamber of Commerce entitled to vote at general meetings of the Chamber.
18. Industrial (first) functional constituency	Members of the Federation of Hong Kong Industries entitled to vote at general meetings of the Federation.
19. Industrial (second) functional constituency	Bodies that are members of The Chinese Manufacturers' Association of Hong Kong entitled to vote at general meetings of the Association.
20. Finance functional constituency	Bodies that are: (1) banks within the meaning of the Banking Ordinance (Cap 155). (2) restricted licence banks within the meaning of the Banking Ordinance (Cap 155). (3) deposit-taking companies within the meaning of the Banking Ordinance (Cap 155).
21. Financial services functional constituency	(1) Exchange participants of a recognized exchange company. (2) Members of The Chinese Gold & Silver Exchange

<u>Column 1</u> <u>Constituency</u>	<u>Column 2</u> <u>Electors</u>
	Society entitled to vote at general meetings of the Society.
22. Sports, performing arts, culture and publication functional constituency	<p>(1) Statutory bodies and registered bodies (other than schools registered under the Education Ordinance (Cap 279) and bodies formed by such schools) that are members of the sports associations affiliated to the Sports Federation & Olympic Committee of Hong Kong, China.</p> <p>(2) Sports associations affiliated to the Sports Federation & Olympic Committee of Hong Kong, China but have no statutory bodies or registered bodies as members.</p> <p>(3) The following district sports associations:</p> <ul style="list-style-type: none">(a) Central & Western District Recreation & Sports Association;(b) Eastern District Recreation & Sports Advancement Association Ltd.;(c) The Federation of Tsuen Wan District Sports & Recreation Association Ltd.;(d) Islands District Sports Association;(e) Kowloon City District Recreation & Sports Council;(f) Kwai Tsing District Sports Association;(g) Kwun Tong Sports Promotion Association Ltd.;(h) Mong Kok District Cultural, Recreational and Sports Association Limited;(i) North District Sports Association;(j) Sai Kung District Sports Association Ltd.;(k) Sha Tin Sports Association Ltd.;(l) Sham Shui Po Sports Association;(m) Southern District Recreation & Sports Council;(n) Tai Po Sports Association Ltd.;(o) Tuen Mun Sports Association Limited;(p) Wanchai District Arts Cultural Recreation & Sports Association Ltd.;(q) Wong Tai Sin District Recreation & Sports Council;(r) Yaumatei and Tsimshatsui Recreation & Sports Association Ltd.;(s) Yuen Long District Sports Association Ltd. <p>(4) Bodies listed in a Gazette notice currently in force made under section 3(5) of the Hong Kong Arts Development Council Ordinance (Cap 472) as organizations for the purpose of section 3(4) of that Ordinance.</p> <p>(5) Statutory bodies and registered bodies, the primary goal of which is the promotion of arts, and to which grants, sponsorship or performance fees have been approved by the Hong Kong Arts Development Council, the Urban Council, the Regional Council, the Provisional Urban</p>

Column 1
Constituency

Column 2
Electors

- Council, the Provisional Regional Council, the Leisure and Cultural Services Department or the Home Affairs Bureau during the relevant period.
- (6) The following district arts and culture associations:
- (a) Central and Western District Association for Culture and Arts;
 - (b) Eastern District Arts Council;
 - (c) Kowloon City District Arts and Culture Council;
 - (d) Kwai Chung and Tsing Yi District Culture and Arts Co-ordinating Association Limited;
 - (e) Kwun Tong District Culture and Recreation Promotion Association ;
 - (f) North District Arts Advancement Association Limited;
 - (g) Sai Kung Culture & Recreational Advancement Association;
 - (h) Sha Tin Arts Association Limited;
 - (i) Shamshuipo Arts Association;
 - (j) Southern District Arts and Culture Association Limited;
 - (k) Tai Po District Arts Advancement Association;
 - (l) Tsuen Wan Culture & Recreation Co-ordinating Association Limited;
 - (m) Tuen Mun Arts Promotion Association;
 - (n) Wong Tai Sin District Arts Council;
 - (o) Yau Ma Tei and Tsim Sha Tsui Culture and Arts Association Limited;
 - (p) Yuen Long District Arts Committee.
- (7) Members of each of the following bodies entitled to vote at general meetings of the body -
- (a) Educational Booksellers' Association, Limited;
 - (b) The Anglo-Chinese Textbook Publishers Organisation Limited;
 - (c) The Hong Kong Educational Publishers Association Limited;
 - (d) The Hong Kong Publishers and Distributors Association;
 - (e) Hong Kong Book & Magazine Trade Association Limited;
 - (f) Hongkong Book and Stationery Industry Association Company Limited.
- (8) Members of the Hong Kong Publishing Federation Limited (other than those referred to in paragraph (7)) entitled to vote at general meetings of the Federation.
- (9) Members of each of the following bodies entitled to vote at general meetings of the body -

Column 1
Constituency

Column 2
Electors

- (a) HK, Kln & NT Motion Picture Industry Association Ltd.;
- (b) Hong Kong Film Awards Association Ltd.;
- (c) International Federation of the Phonographic Industry (Hong Kong Group) Limited;
- (d) Movie Producers and Distributors Association of Hong Kong Ltd.;
- (e) Music Publishers Association of Hong Kong Ltd.;
- (f) Hong Kong Theatres Association Ltd.
- (10) Corporate proprietors, the principal business of which is publication, registered under the Registration of Local Newspapers Ordinance (Cap 268).
- (11) Corporate proprietors of newspaper distributors licensed under the Newspapers Registration and Distribution Regulations (Cap 268 sub. leg. B).
- (12) bodies that are holders of one or more of the following classes of licences granted under the Broadcasting Ordinance (Cap 562) –
 - (a) licences to provide a domestic free television programme service;
 - (b) licences to provide a domestic pay television programme service;
 - (c) licences to provide a non-domestic television programme service.
- (13) holders of licenses granted under Part IIIA of the Telecommunications Ordinance (Cap 106) (sound broadcasting licences).
- (14) All Stars Sports Association Ltd.
- (15) The Amateur Lyric Writers' Association of Hong Kong.
- (16) Artiste Training Alumni Association Limited.
- (17) Composers and Authors Society of Hong Kong Limited.
- (18) Friends of the Art Museum, The Chinese University of Hong Kong Limited.
- (19) The Friends of the Hong Kong Museum of Art.
- (20) HK Film Directors' Guild Ltd.
- (21) Hong Kong Anthropological Society.
- (22) Hong Kong Archaeological Society.
- (23) The Hong Kong Children's Choir.
- (24) Hong Kong Chinese Orchestra.
- (25) Hong Kong Chinese Press Association.
- (26) Hong Kong & Macau Cinema and Theatrical Enterprise Association Limited.
- (27) Hong Kong Cinematography and Television Lighting Association Limited.
- (28) Hong Kong Curators Association.
- (29) Hong Kong Dance Company Limited.
- (30) Hong Kong Federation of Journalists Ltd.

Column 1
Constituency

Column 2
Electors

- | | | |
|-----|---|---|
| | (31) | Hong Kong Festival Fringe Ltd. |
| | (32) | Hong Kong Film Academy. |
| | (33) | Hong Kong Film Arts Association Limited. |
| | (34) | Hong Kong History Society. |
| | (35) | Hong Kong Intellectual Property Society. |
| | (36) | Hong Kong Journalists Association. |
| | (37) | The Hong Kong Mass Media Professionals Association Ltd. |
| | (38) | Hong Kong Museum of Medical Sciences Society. |
| | (39) | Hong Kong News Executives' Association, Limited. |
| | (40) | Hong Kong PEN (English) Centre. |
| | (41) | Hong Kong Performing Artistes Guild Ltd. |
| | (42) | Hong Kong Philharmonic Orchestra. |
| | (43) | Hong Kong Press Photographers Association. |
| | (44) | Hong Kong Recreation Management Association Limited. |
| | (45) | Hong Kong Repertory Theatre Limited. |
| | (46) | Hong Kong Screen Writers' Guild Ltd. |
| | (47) | Hong Kong Sports Association of the Deaf. |
| | (48) | Hong Kong Sports Press Association Ltd. |
| | (49) | Hong Kong Stuntman Association Ltd. |
| | (50) | Hong Kong Tai Chi Association. |
| | (51) | Hong Kong United Arts Entertainment Co. Ltd. |
| | (52) | Min Chiu Society. |
| | (53) | New Territories Regional Sports Association. |
| | (54) | The Newspaper Society of Hong Kong. |
| | (55) | Pop-Music Authors Society of Hong Kong. |
| | (56) | Royal Asiatic Society Hong Kong Branch. |
| | (57) | Sail Training Association of Hong Kong Limited. |
| | (58) | Society of Cinematographers (Hong Kong) Limited. |
| | (59) | Society of Film Editors (HK) Ltd. |
| | (60) | South China Film Industry Workers Union. |
| | (61) | South China Research Circle. |
| | (62) | Swimming Teacher's Association Hong Kong. |
| | (63) | Videotage. |
| | (64) | Zuni Icosahedron. |
| | (65) | Federation of Hong Kong Film Workers Limited. |
| | (66) | Hong Kong Movie Production Executives Association Limited. |
| 23. | Import and export functional constituency | (1) Companies licensed under the Dutiable Commodities Ordinance (Cap 109) for the import or export, or import and export, of dutiable commodities. |
| | | (2) Companies registered under the Motor Vehicles (First Registration Tax) Ordinance (Cap 330) for the import of motor vehicles for use in Hong Kong. |
| | | (3) Companies licensed under the Control of Chemicals |

<u>Column 1</u> <u>Constituency</u>	<u>Column 2</u> <u>Electors</u>
	<p>Ordinance (Cap 145) for the import or export, or import and export, of controlled chemicals.</p> <p>(4) Companies licensed under the Import and Export Ordinance (Cap 60) for the import or export, or import and export, of outboard engines and left hand drive vehicles and for the export of prescribed articles.</p> <p>(5) Members of each of the following bodies entitled to vote at general meetings of the body -</p> <ul style="list-style-type: none">(a) Association of Hong Kong Photographic Equipment Importers Ltd.;(b) Hong Kong & Kowloon Steel and Metal Importers and Exporters Association Ltd.;(c) Hong Kong Chinese Importers' & Exporters' Association;(d) Hong Kong Exporters' Association;(e) Hong Kong Fresh Fruits Importers Association Ltd.;(f) Hong Kong General Association of Edible Oil Importers & Exporters Ltd.;(g) Hong Kong Maize and Feed Importers Association Ltd.;(h) Hongkong Rice Importers & Exporters Association;(i) Hongkong Watch Importers' Association;(j) The Hong Kong Food, Drink & Grocery Association;(k) Hong Kong & Kowloon Light Industrial Products Importers & Exporters Association Limited;(l) Nanyang Importers and Exporters Association;(m) Hong Kong Industrial Production Trading Association Limited;(n) Industrial Chemical Merchants' Association Limited;(o) South-China Paper Merchants Association Limited;(p) Wah On Exporters & Importers Association;(q) The Hong Kong Shippers' Council;(r) The Shippers' Association of Hong Kong.
24. Textiles and garment functional constituency	<p>(1) Corporate members of the Textile Council of Hong Kong Limited (other than those referred to in paragraph (2)(a) to (l)) entitled to vote at general meetings of the council.</p> <p>(2) Corporate members of each of the following bodies entitled to vote at general meetings of the body -</p> <ul style="list-style-type: none">(a) Federation of Hong Kong Cotton Weavers;(b) Federation of Hong Kong Garment Manufacturers;(c) Hong Kong Chinese Textile Mills Association;(d) Hong Kong Cotton Made-up Goods Manufacturers Association Ltd.;(e) Hong Kong Cotton Spinners Association;

Column 1
Constituency

Column 2
Electors

- (f) Hong Kong Garment Manufacturers Association Ltd.;
 - (g) Hong Kong Knitwear Exporters & Manufacturers Association Ltd.;
 - (h) Hong Kong Woollen & Synthetic Knitting Manufacturers' Association, Ltd.;
 - (i) Hong Kong Association of Textile Bleachers, Dyers, Printers & Finishers Ltd.;
 - (j) Hong Kong Weaving Mills Association;
 - (k) Hongkong Wool & Synthetic Spinners Association Ltd.;
 - (l) The Hong Kong General Chamber of Textiles Limited.
- (3) Members of the Hong Kong Institution of Textile and Apparel entitled to vote at general meetings of the Institution.
- (4) Textiles & Clothing manufacturers registered under the Factory Registration of the Trade and Industry Department for the purpose of applying for the certificate of Hong Kong origin.
- (5) Textiles traders who are registered by the Director-General of Trade and Industry as Textiles Traders pursuant to regulation 5A of the Import and Export (General) Regulations (Cap 60 sub. leg. A) and have been so registered for a period of 12 months immediately before making the application for registration as an elector and are carrying on the business of -
- (a) importing textiles from any country or place;
 - (b) exporting textiles that are not entitled to a certificate of Hong Kong origin to any country or place; or
 - (c) exporting textiles that are entitled to a certificate of Hong Kong origin to a country or place with which Hong Kong does not have a bilateral textiles agreement to control exports of textiles from Hong Kong to the country or place.
25. Wholesale and retail functional constituency
- Members of each of the following bodies entitled to vote at general meetings of the body -
- (1) The Anglo-Chinese Vegetable Wholesale Merchants Association Limited;
 - (2) Association of Better Business & Tourism Services;
 - (3) Cheung Sha Wan Poultry United Wholesalers Association Ltd.;
 - (4) Chinese Medicine Merchants Association Ltd.;
 - (5) Chinese Merchants (H.K.) Association;

Column 1
Constituency

Column 2
Electors

- (6) Chinese Paper Merchants Association;
- (7) The Cosmetic & Perfumery Association of Hong Kong Ltd.;
- (8) Eastern District Fresh Fish Merchants' Society;
- (9) Federation of Hong Kong, Kowloon and New Territories Hawkers Associations;
- (10) The Federation of Hong Kong Watch Trades and Industries Ltd.;
- (11) HK Vegetable Wholesaler Community;
- (12) Hong Kong and Kowloon Bamboo Goods Merchants Association Limited;
- (13) Hong Kong and Kowloon Electrical Appliances Merchants Association Ltd.;
- (14) Hong Kong & Kowloon Electro-Plating Trade Merchants Association Ltd.;
- (15) Hong Kong & Kowloon European Dress Merchants Association;
- (16) Hong Kong & Kowloon Fresh Water Fish Merchants' & Buyers' Association Limited;
- (17) Hong Kong & Kowloon Fruit & Vegetable Employees & Employers Guild;
- (18) Hong Kong & Kowloon Furniture & Shop Fittings Merchants Association;
- (19) Hong Kong & Kowloon General Association of Liquor Dealers and Distillers;
- (20) Hong Kong & Kowloon Machine Made Paper Merchants Association Ltd.;
- (21) Hong Kong and Kowloon Machinery and Instrument Merchants Association Ltd.;
- (22) Hong Kong & Kowloon Marine Products Merchants Association Ltd.;
- (23) Hong Kong & Kowloon Plastic Products Merchants United Association Limited;
- (24) Hong Kong & Kowloon Poultry Dealers Guild;
- (25) The Hong Kong & Kowloon Provisions, Wine & Spirit Dealers' Association;
- (26) Hong Kong & Kowloon Rattan Ware Merchants Association (Wing-Hing-Tong);
- (27) The Hong Kong and Kowloon Rice Retailers' General Association Ltd.;
- (28) Hong Kong and Kowloon Salt Merchants' Association;
- (29) Hong Kong & Kowloon Sauce & Preserved-Fruit Amalgamated Employers Association;
- (30) Hong Kong & Kowloon Tea Trade Merchants Association Ltd.;
- (31) Hong Kong & Kowloon Timber Merchants Association;
- (32) Hong Kong & Kowloon Vermicelli & Noodle

Column 1
Constituency

Column 2
Electors

- (33) Manufacturing Industry Merchants' General Association;
- (34) Hong Kong Art Craft Merchants Association, Ltd.;
- (35) Hong Kong Dried Seafood and Grocery Merchants Association Limited;
- (36) Hong Kong Dyestuffs Merchants Association Limited;
- (37) Hong Kong Egg Merchants Association (Fung-Kwai-Tong);
- (38) Hong Kong Embroidery Merchants Association Limited;
- (39) Hong Kong Flour Merchants' Association;
- (40) Hong Kong Flower Dealers & Workers Association;
- (41) Hong Kong Flower Retailers Association;
- (42) The Hong Kong Food Council Limited;
- (43) Hong Kong Fresh Fish Merchants Association;
- (44) Hong Kong Fur Federation;
- (45) Hong Kong Furniture & Decoration Trade Association Limited;
- (46) Hong Kong General Chamber of Pharmacy Limited;
- (47) Hong Kong Glass and Mirror Merchants and Manufacturers Association Company Limited;
- (48) Hong Kong Jewellers' & Goldsmiths' Association Limited;
- (49) Hong Kong Leather Shoe And Shoe Material Merchants Association Ltd.;
- (50) Hong Kong Live Pig Trade Merchants' Association;
- (51) The Hong Kong Medicine Dealers' Guild.
- (52) Hong Kong Metal Merchants Association;
- (53) The Hong Kong Oil Merchants Association Ltd.;
- (54) Hong Kong Paints & Pigments Merchants Association Ltd.;
- (55) Hong Kong Petroleum, Chemicals and Pharmaceutical Materials Merchants Association Ltd.;
- (56) Hong Kong Photo Marketing Association Limited;
- (57) Hong Kong Piece Goods Merchants' Association;
- (58) Hong Kong Plastic Material Suppliers Association Ltd.;
- (59) Hong Kong Plumbing and Sanitary Ware Trade Association Ltd.;
- (60) Hong Kong Provision & Grocery General Commercial Chamber;
- (61) Hong Kong Record Merchants Association Ltd.;
- (62) Hong Kong Rice Suppliers Association Limited;
- (63) Hong Kong Retail Management Association Ltd.;
- (64) Hong Kong Silk Piece-Goods Merchants' Association;
- (65) Hong Kong Stamp and Coin Dealers Association Ltd.;
- (66) The Hong Kong Video Industry Association Ltd.;
- (67) Hong Kong Yee Yee Tong Chinese Medicine Merchants Association Ltd.;
- (68) The Hongkong & Kowloon General Merchandise

Column 1
Constituency

Column 2
Electors

- | | | |
|-----|--|--|
| | (68) | Merchants' Association;
Hongkong Kowloon New Territories & Overseas Fish Wholesalers Association Limited; |
| | (69) | Industrial Chemical Merchants' Association Ltd.; |
| | (70) | The Kowloon Cheung Sha Wan Wholesale Vegetable Market (Importers) Recreation Club; |
| | (71) | Kowloon Fresh Fish Merchants Association; |
| | (72) | Kowloon Fresh Meat Retailers' Association Ltd.; |
| | (73) | The Kowloon Pearls, Precious Stones, Jade, Gold & Silver Ornament Merchants Association; |
| | (74) | Kowloon Poultry Laan Merchants Association; |
| | (75) | The Merchants Association of First Wholesalers/Jobbery of Imported Fresh Fruits & Vegetables Limited; |
| | (76) | The Mongkok Vegetable Wholesale Merchants Association Company Ltd.; |
| | (77) | The Motor Traders Association of Hong Kong; |
| | (78) | Nam Pak Hong Association; |
| | (79) | Po Sau Tong Ginseng & Antler Association Hong Kong Ltd.; |
| | (80) | The Rice Merchants' Association of Hong Kong Limited; |
| | (81) | Shau Kei Wan Fishery Merchants Association; |
| | (82) | Tobacco Institute of Hong Kong Ltd.; |
| | (83) | Umbrella Dealers Association, Hong Kong and Kowloon; |
| | (84) | Yuet Sum Kong Vegetable Association (Hong Kong) Co.; |
| | (85) | Kowloon Fruit & Vegetable Merchants Association Limited; |
| | (86) | The Hong Kong And Kowloon Electric Trade Association; |
| | (87) | Hong Kong Poultry Wholesalers Association; |
| | (88) | Diamond Federation of Hong Kong, China Limited. |
| 26. | Information technology functional constituency | (1) Fellows and Full Members of the Hong Kong Computer Society entitled to vote at general meetings of the Society.
(2) Fellows, Members and Graduate Members of Information Technology Division of the Hong Kong Institution of Engineers who are entitled to vote at general meetings of the Division.
(3) Professional Members of the Association for Computing Machinery, Hong Kong Chapter entitled to vote at general meetings of the Association.
(4) Fellows, Senior Members and Full Members of the Institute of Electrical and Electronics Engineers, Inc., Hong Kong Section, Computer Chapter entitled to vote at general meetings of the Institute.
(5) Fellows, Senior Members and Full Members of the |

Column 1
Constituency

Column 2
Electors

- Institute of Electrical and Electronics Engineers, Inc., Hong Kong Section, Hong Kong Joint Chapter on Circuits and Systems/Communications entitled to vote at general meetings of the Institute.
- (6) Fellows and Corporate Members of The Institution of Electrical Engineers Hong Kong entitled to vote at general meetings of the Institution.
- (7) Fellows, Members and Associate Members of the British Computer Society (Hong Kong Section) entitled to vote at general meetings of the Society.
- (8) Fellows, Senior Professional Members and Professional Members of The Hong Kong Association for Computer Education entitled to vote at general meetings of the Association.
- (9) Full Members (Information Technology) of the Hong Kong Society of Medical Informatics Limited entitled to vote at general meetings of the Society.
- (10) Full Members of the Information and Software Industry Association Limited entitled to vote at general meetings of the Association.
- (11) Ordinary Members of the Hong Kong Telemedicine Association entitled to vote at general meetings of the Association.
- (12) the eligible persons of the following bodies -
- (a) Hong Kong & Mainland Software Industry Cooperation Association Limited;
 - (b) Information Systems Audit and Control Association (Hong Kong Chapter) Limited;
 - (c) Internet Professionals Association Limited;
 - (d) Professional Information Security Association.
- (13) Corporate members of each of the following bodies entitled to vote at general meetings of the body -
- (a) Hong Kong Information Technology Federation Limited;
 - (b) Hong Kong Internet Service Providers Association;
 - (c) Hong Kong Radio Paging Association Ltd.;
 - (d) Internet & Telecom Association of Hong Kong Limited;
 - (e) Hong Kong Wireless Technology Industry Association Limited;
 - (f) The Society of Hong Kong External Telecommunications Services Providers Limited.
- (14) Bodies that are holders of one or more of the following classes of licences granted by the Telecommunications Authority under the Telecommunications Ordinance (Cap 106) -
- (a) Fixed Telecommunications Network Services

<u>Column 1</u> <u>Constituency</u>	<u>Column 2</u> <u>Electors</u>
	licences; (b) Public Non-exclusive Telecommunications Service licences; (c) Public Radiocommunication Service licences; (d) Satellite Master Antenna Television licences; (e) Broadcast Relay Station licences; (f) Broadcast Radio Relay Station licences; (g) Carrier licences. (15) APT Satellite Co. Ltd. (16) Asia Satellite Telecommunications Company Limited.
27. Catering functional constituency	(1) Holders of food business licenses under the Public Health and Municipal Services Ordinance (Cap 132). (2) The Association for the Hong Kong Catering Services Management Limited. (3) The Association of Restaurant Managers Limited. (4) Federation of Hong Kong Restaurant Owners Limited. (5) The Hong Kong Restaurant and Eating House Merchants General Association. (6) Hong Kong Catering Industry Association Limited.
28. District Council functional constituency	Members of the District Councils established under the District Councils Ordinance (Cap 547).

Note : (1) In item 22 of this Appendix -

- (a) “registered bodies” (註冊團體) means bodies which are registered or exempt from registration under, or incorporated by, any laws of Hong Kong.
- (b) “relevant period” (有關期間), in relation to a statutory body or registered body, means the period from 1 April 1994 to the date on which the statutory body or registered body applies for registration as an elector of the sports, performing arts, culture and publication functional constituency; or if the statutory body or registered body applies for such registration on or after 18 July 2003, the period of 6 years immediately preceding the date on which it so applies.
- (c) “statutory body” (法定團體) means a body established or constituted by or under the authority of an Ordinance.

(2) In item 26(12) of this Appendix, the “eligible persons” means –

- (a) Hong Kong & Mainland Software Industry Cooperation Association Limited – Full Members, the major business of which, as confirmed by the Association, has been in the research, development or application of information technology or computer software during the relevant period; and which are entitled to vote at general meetings of the Association;
- (b) Information Systems Audit and Control Association (Hong Kong Chapter)

Limited – Ordinary Members who are confirmed by the Association to have been holders of the Certified Information Systems Auditor Certification (CISA) during the relevant period; and entitled to vote at general meetings of the Association;

- (c) Internet Professionals Association Limited – Members who are confirmed by the Association to have had experience in the information technology field, as specified in the constitution of the Association, during the relevant period; and entitled to vote at general meetings of the Association; and
- (d) Professional Information Security Association – Full Members who are confirmed by the Association to have been holders of the Certified Information Systems Security Professional Certification (CISSP) during the relevant period; and entitled to vote at general meetings of the Association,

where the “relevant period”, in relation to a person, means the period of 4 years immediately preceding the date on which that person applies for registration as an elector of the information technology functional constituency.

The Preferential Elimination System of Voting-
(applicable to the election of the 4 Special Functional Constituencies)
How Votes Are Counted
(with Annex showing Working Examples)

1. All valid ballot papers will be sorted with reference to the candidate for whom the first preference vote has been recorded.

2. The result of an election will be ascertained by a count of the first preference votes received by each of the candidates. The candidate who receives an absolute majority (ie over 50%) of all the first preference votes received by the candidates will be declared elected (see Example 1 in the Annex). However, where each of the ballot papers contains only a first preference vote without any other valid preference marked on it, the candidate who obtains the highest number of the first preference votes will be elected.

3. Where no candidate has received an absolute majority of all the first preference votes received by the candidates:
 - (a) If each of the candidates has received an equal number of first preference votes, the result of the election will be determined by lot (see paras. 3.2 - 3.4 in the Annex).

 - (b) Otherwise, an elimination process accompanied with a transfer of votes will be carried out, ie the candidate(s) with the least number of votes will be eliminated and his/their votes will be transferred to the other (remaining) candidates according to the next available preference recorded on his/their ballot papers (see Example 2 in the Annex).

4. The process in para. 3(b) above will be repeated until:
- (a) a candidate obtains an absolute majority of the aggregate of the total number of votes (both preference votes and transferred votes) - that candidate will then be declared elected;
 - (b) only one candidate is remaining - he shall be elected; or
 - (c) each of the remaining candidates has received an equal number of votes (ie the total number of the first preference votes and the transferred votes), in which case the result of the election will be determined by lot.

The Preferential Elimination System of Voting

WORKING EXAMPLES

Example 1 (where an absolute majority is obtained at the first count)

1.1 At the first count, only first preference votes are counted. The results are as follows :-

First Count	Exhausted Ballot Papers	Valid Ballot Papers	A Votes %	B Votes %	C Votes %	D Votes %	E Votes %
Total Number of Votes		100	51 51.00	29 29.00	10 10.00	7 7.00	3 3.00
			Elected				

1.2 Candidate A is elected as he has obtained an absolute majority (over 50%) of all the first preference votes.

Example 2 (where an elimination process and a transfer of votes take place)

2.1 In this example, the results of the first count in which only first preference votes are counted are as follows :-

First Count	Exhausted Ballot Papers	Valid Ballot Papers	A Votes %	B Votes %	C Votes %	D Votes %	E Votes %
Total Number of Votes		100	3 3.00	2 2.00	44 44.00	44 44.00	7 7.00

2.2 No candidate has obtained an absolute majority of all the first preference votes. Candidate B, who has obtained the least number of first preference votes, is eliminated.

2.3 A second count is then conducted. The 2 ballot papers which show Candidate B as the first preference are transferred to the remaining Candidates (A, C, D and E) according to the next available (second) preference shown on them. For any ballot papers which express no available preference for any of the remaining candidates or where the next available preference is not clear (eg where there is no consecutive preference or where the same preference is marked for 2 or more candidates), they are set aside as "exhausted" and are excluded from any subsequent counting of the total number of valid votes for the purpose of calculating an absolute majority of votes of the winning candidate.

2.4 It is assumed that the next available (second) preferences shown on these 2 ballot papers are as follows :-

Candidates of next available preference	Number of votes
A	0
C	1
D	1
E	0
Nil	0 (exhausted)
	2

2.5 The results of the second count are as follows :-

Second Count	Exhausted Ballot Papers	Valid Ballot Papers	A Votes %	C Votes %	D Votes %	E Votes %
Own 1st preference votes	-	98	3	44	44	7
Preference votes transferred from Candidate B	0	2	0	1	1	0
Total Number of Votes	0	100	3 3.00	45 45.00	45 45.00	7 7.00

2.6 Still no candidate has obtained an absolute majority of all the valid votes in circulation. Candidate A, who has obtained the least total number of votes at this stage, is eliminated.

2.7 A third count is then conducted. The 3 ballot papers which show Candidate A as the first preference are transferred to the remaining candidates (C, D and E) according to the next available (second) preference marked on them. If any of these ballot papers shows Candidate B who has already been eliminated at the first count as the 2nd preference, it is transferred to one of the remaining candidates according to the next available (third) preference shown on it. It is assumed that the next available preferences for the remaining candidates shown on the 3 ballot papers under Candidate A are as follows :-

Candidates of next available preference	Number of votes
C	2
D	0
E	0
Nil	1 (exhausted)
	3

2.8 The results of the third count are as follows :-

Third Count	Exhausted Ballot Papers	Valid Ballot Papers	C		D		E	
			Votes	%	Votes	%	Votes	%
Own 1st preference votes	-	95	44		44		7	
Preference votes transferred from Candidate B	0	2	1		1		0	
Preference votes transferred from Candidate A	1	2	2		0		0	
Total Number of Votes	1	99	47	47.47	45	45.45	7	7.07

2.9 Still no candidate has obtained an absolute majority of all the valid votes in circulation. Candidate E, who has obtained the least total number of votes at this stage, is eliminated.

2.10 A fourth count is then conducted. The 7 ballot papers which show Candidate E as the first preference are transferred to the remaining Candidates C and D according to the next available (second) preference marked on them. If any of these ballot papers shows Candidate B or Candidate A (both have already been eliminated) as the 2nd preference, it is transferred to one of the remaining candidates according to the next available (third) preference shown on it. If any of these ballot papers shows Candidate A and Candidate B as 2nd and 3rd preferences (or vice versa), it is transferred to the remaining candidates according to the next available (fourth) preferences shown on it. It is assumed that the next available preference shown after Candidate E for the remaining candidates on the 7 ballot papers are as follows :-

Candidates of next available preference	Number of votes
C	4
D	2
Nil	1 (exhausted)
	7

2.11 The results of the fourth count are as follows :-

Fourth Count	Exhausted Ballot Papers	Valid Ballot Papers	C		D	
			Votes	%	Votes	%
Own 1st preference votes		88	44		44	
Preference votes transferred from Candidate B	0	2	1		1	
Preference votes transferred from Candidate A	1	2	2		0	
Preference votes transferred from Candidate E	1	6	4		2	
Total Number of Votes	2	98	51	52.04	47	47.96

2.12 Candidate C has now obtained an absolute majority of all the valid votes in circulation and is declared elected.

2.13 The following table shows the entire counting process :-

	Exhausted Ballot Papers	Valid Ballot Papers	A Votes %	B Votes %	C Votes %	D Votes %	E Votes %
First Count	-	100	3 3.00	2 2.00 Eliminated	44 44.00	44 44.00	7 7.00
Second Count	0	2	0		1	1	0
Total Number of votes	0	100	3 3.00 Eliminated		45 45.00	45 45.00	7 7.00
Third Count	1	2			2	0	0
Total Number of votes	1	99			47 47.47	45 45.45	7 7.07 Eliminated
Fourth Count	1	6		4	2		
Total Number of votes	2	98		51 52.04	47 47.96		
					Elected		

The Drawing of Lots

3.1 The result of the election will be determined by the drawing of lots if :-

- (a) in the first count, no candidate has received an absolute majority of all the first preference votes received by the candidates and each of the candidates has received an equal number of first preference votes; or

- (b) after the elimination process and the transfer of votes have been carried out, no candidate has received an absolute majority of the aggregate of the total number of votes and each of the remaining candidates has received an equal number of votes (ie the total number of the first preference votes and the transferred votes).

3.2 Ten lots will be used, each being allocated a number ranging from "1" to "10". All lots will be placed in an empty opaque bag.

3.3 The candidates concerned will take turn (in the order in which their names are listed on the ballot paper) to draw a lot, which will be put back into the bag before the next candidate makes his draw. The candidate whose lot carries the higher number will emerge as the winner. Number "10" is the highest number.

3.4 This method as to how lots should be drawn allows each candidate to have an equal opportunity to try his luck. A candidate may even by chance (1 in 10) draw the same lot as his opponent. In such an unlikely event, a second draw will be conducted. [For detailed arrangement, please make reference to para. 3.31 (a) and (b) of Chapter 3.]

**The Combined Polling Arrangements -
Polling Stations for Various Kinds of Electors in the General Election**

1. The general election consists of elections of 5 geographical constituencies (“GCs”), 24 ordinary functional constituencies (“FCs”), and 4 special functional constituencies (“SFCs”).
2. Each of the 4 SFCs has a small electorate and the voting system applicable to them is different from that applicable to the other 24 FCs.
3. An elector can simply be an elector of the GC, but any elector of the 24 FCs or 4 SFCs is also an elector of one of the 5 GCs.
4. A person cannot be an elector of more than one of the 24 FCs and 4 SFCs.
5. All GC electors are individuals. However, some of the 24 FCs and 4 SFCs have corporate electors. A corporate elector can only cast its FC vote by an authorised representative (“AR”) it has appointed. An AR must be a GC elector (see para. 3.12 of Chapter 3). A person who is an AR for one FC/SFC cannot be AR for another FC/SFC, but he can be an elector of another FC/SFC. Therefore, a person can be an FC/SFC elector and also an AR of another FC/SFC.
6. An one-stop service is aimed to be provided to all kinds of persons, so that a person only needs to go to one polling station to cast all the votes which he is entitled to cast. Under the combined polling arrangement, each GC elector is allocated to a polling station according to his residential address in the final register for GCs. He will be issued at the polling station the number of ballot papers to which he is entitled as the GC elector, elector and/or AR of an FC/SFC, as the case may be. There will be no other polling station designated for any of the 24 FCs or the 4 SFCs; and their electors and ARs will have to cast their votes in polling stations designated for GCs.
7. A cardboard will be issued to each person at the same time as he is issued with one or more ballot paper, in order to ensure that he must insert the

ballot paper(s) issued to him in the ballot boxes before he leaves the polling station. A **white** cardboard will be issued to a person with 1 ballot paper, a **red** cardboard to a person with 2 ballot papers and a **blue** cardboard to a person with 3 ballot papers. The cardboard will have to be handed back by the person to the polling officer manning the ballot boxes at the time immediately before that person inserts his ballot papers into the boxes.

8. There are going to be 2 kinds of ballot boxes overall, in any polling station :
 - (a) ballot box for the GCs (white in colour); and
 - (b) ballot box for the mixed FCs and SFCs (red in colour).

9. The polling arrangements, in their entirety, consist of only 7 scenarios. Each of the scenarios is explained below, and a table containing the 7 scenarios is also provided for easy reference.

THE 7 SCENARIOS

At the local GC polling station :

1. **A GC elector who has only his GC vote** - 1 GC ballot paper for the local GC. [The person shall insert his GC ballot paper into the white box.]
2. **An FC elector/AR** - 1 GC ballot paper for the local GC + 1 FC ballot paper. [The person shall insert his GC ballot paper into the white box and his FC ballot paper into the red box.]
3. **An FC AR who is also an elector of another FC** - 1 GC ballot paper for the local GC + 2 FC ballot papers. [The person shall insert his GC ballot paper into the white box and his 2 FC ballot papers into the red box.]
4. **An SFC elector/AR** - 1 GC ballot paper for the local GC + 1 SFC ballot paper. [The person shall insert his GC ballot paper into the white box and his SFC ballot paper into the red box.]
5. **An SFC AR who is also an elector of an FC** - 1 GC ballot paper for the local GC + 1 SFC ballot paper + 1 FC ballot paper for the appropriate FC. [The person shall insert his GC ballot paper into the white box, and both his SFC ballot paper and his FC ballot paper into the red box.]
6. **An SFC elector who is also an AR of an FC** - the same as in Scenario 5.
7. **An SFC elector who is also an AR of another SFC** - 1 GC ballot paper for the local GC + 1 SFC ballot paper as elector + 1 SFC ballot paper as AR. [The person shall insert his GC ballot paper into the white box, and his SFC ballot paper and his SFC AR ballot paper into the red box.]

The 7 Scenarios of Polling Arrangements

Type of Elector/AR			No. of Ballot Papers Issued	Cardboard Issued
GC	FC	SFC		
Yes			1	white
Yes	Elector or AR		2	red
Yes	Elector and AR		3	blue
Yes		Elector or AR	2	red
Yes	Elector	AR	3	blue
Yes	AR	Elector	3	blue
Yes		Elector and AR	3	blue

Methods of Folding of Election Advertisement
郵寄選舉廣告宜採用的摺疊方法

Figure 1 : Folder of A4 (296mm) size
圖示一：對摺的A4(296毫米)尺寸紙張

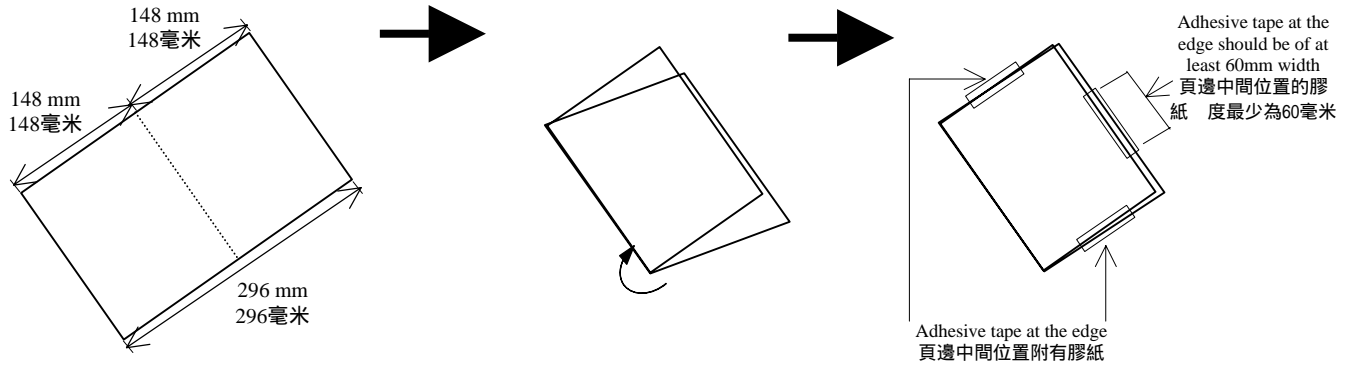

Figure 2 : Folder of A4 (296mm) size with 2 folds
圖示二：兩摺的A4(296毫米)尺寸紙張

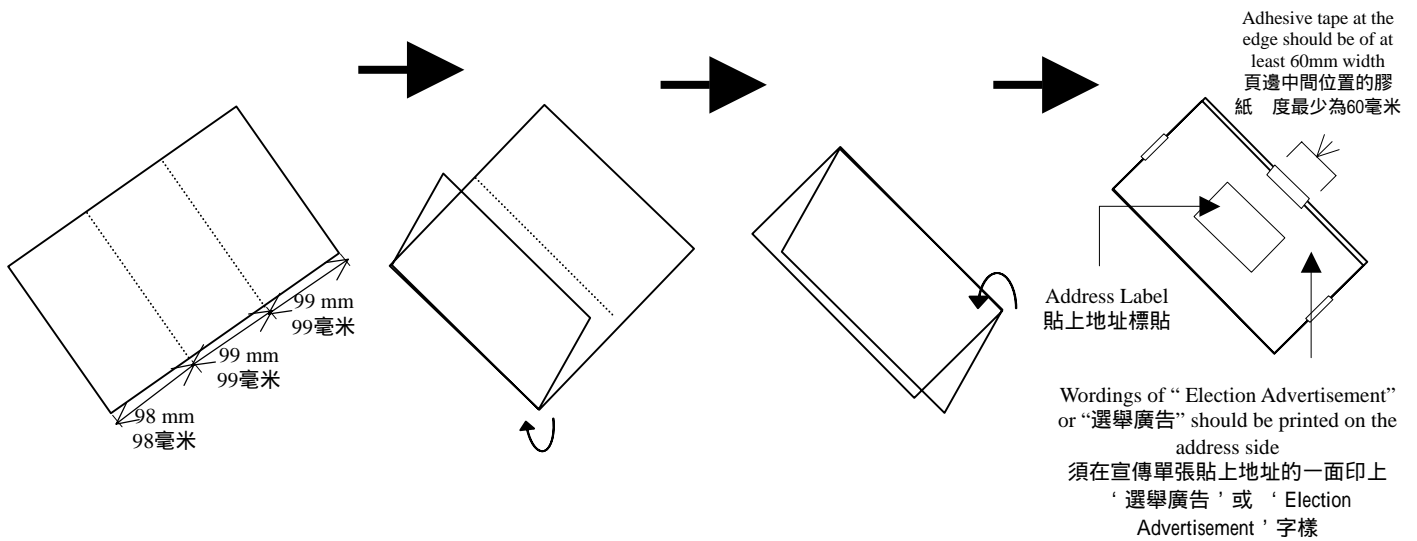

Figure 3 : Folder of A4 (296mm) size with 2 folds
圖示三：兩摺的A4 (296毫米)尺寸紙張

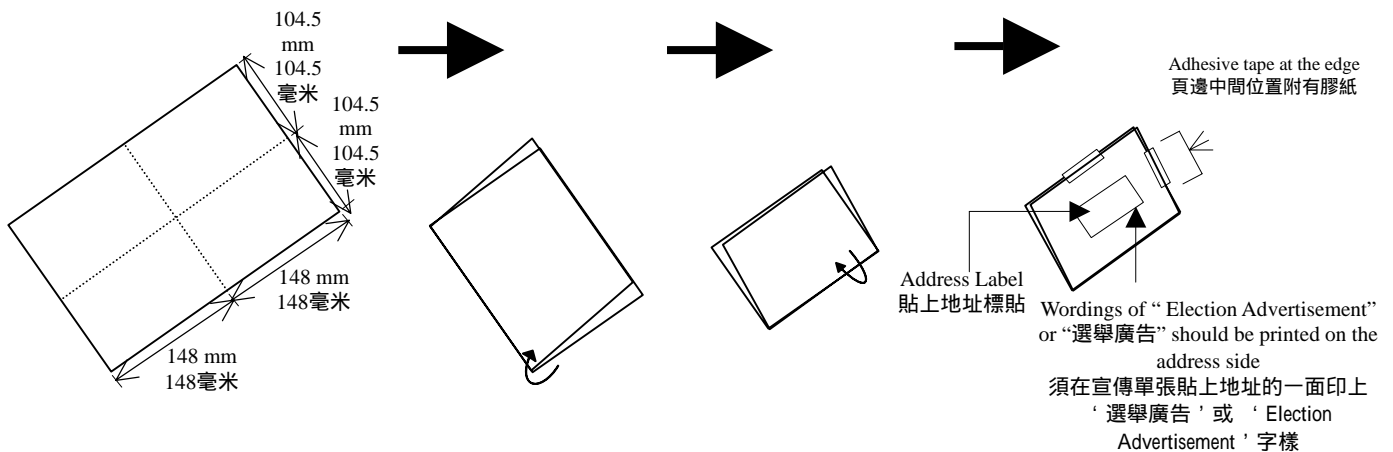

Figure 4 : Folder of A4 (296mm) size sealed with address label
圖示四：以地址標貼封口的A4(296毫米)尺寸紙張

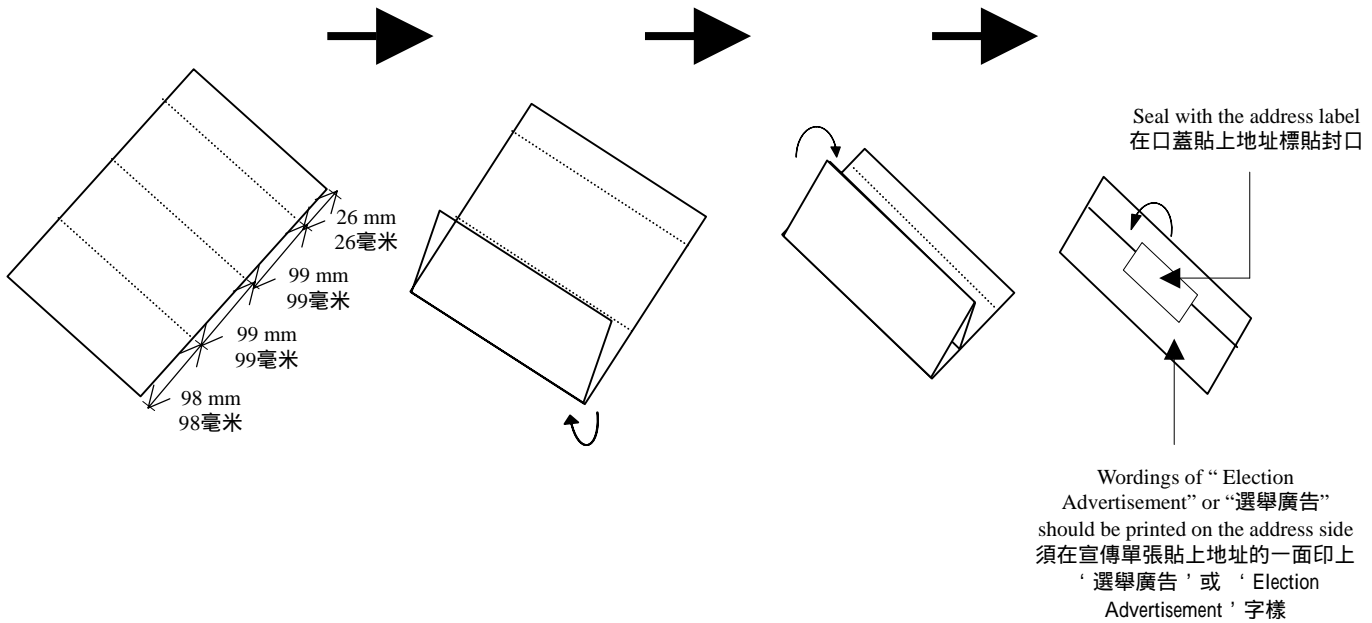
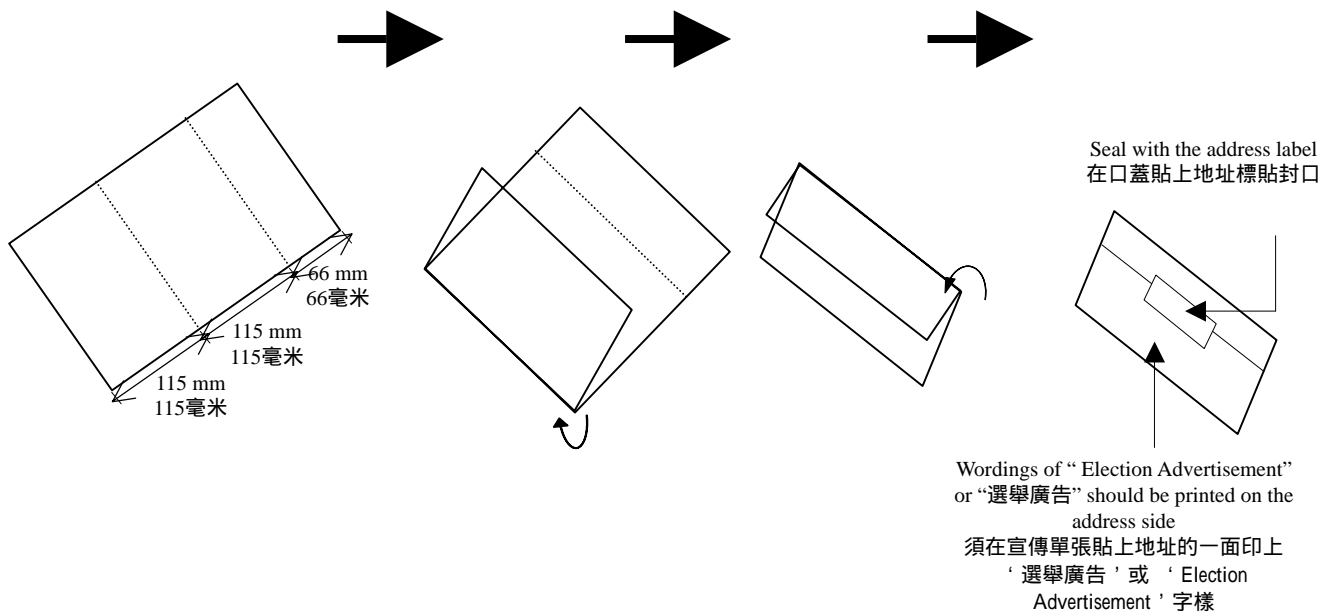

Figure 5 : Folder of A4 (296mm) size sealed with address label
圖示五：以地址標貼封口的A4(296毫米)尺寸紙張



List of Posting Offices for Election Communication

- (i) Manager (Retail Business/Hong Kong)
Address: 1M/F, General Post Office
2 Connaught Place, Central, Hong Kong
Tel : 2921 2303
Fax : 2868 1442

The District and Posting Offices for which the Manager (Retail Business/Hong Kong) is responsible:

District	Posting Office	Address
Central and Western	General Post Office	2 Connaught Place, Central Tel : 2921 2333
	Sai Ying Pun Post Office	G/F, 27 Pok Fu Lam Road, Sai Ying Pun Tel : 2546 6075
Wan Chai	Wan Chai Post Office	2/F, Wu Chung House, 197-213 Queen's Road East, Wan Chai Tel : 2892 5031
Eastern	Eastern Delivery Office	1/F, Eastern Law Courts Building, 29 Tai On Street, Sai Wan Ho Tel : 2886 6577
	Shau Kei Wan Post Office	G/F, Perfect Mount Gardens, 1 Po Man Street, Shau Kei Wan Tel : 2560 2071
	Tsat Tsz Mui Post Office	Shops 1, 6, 7 & 11, G/F, Block C, Model Housing Estate, 770 King's Road, North Point Tel : 2561 7235
Southern	Aberdeen Post Office	G/F, Kam Fung Building, 171 Aberdeen Main Road/Sai On Street, Aberdeen Tel : 2555 9960
	Ap Lei Chau Post Office	G/F, Shop 13-16, Lei Ning House, Ap Lei Chau Estate, Ap Lei Chau Tel : 2553 5971
	Wah Fu Post Office	Flat No. 423-424 , Wah Chun House, Wah Fu Estate, Aberdeen Tel : 2551 2014

District	Posting Office	Address
Islands (excluding Tung Chung)	Discovery Bay Post Office	Shop 12A, G/F, Block C, Discovery Bay Plaza, Discovery Bay, Lantau Island Tel : 2987 6046
	Mui Wo Post Office	G/F, Mui Wo Government Offices Building, 2 Ngan Kwong Wan Road, Mui Wo, Lantau Island Tel : 2984 8198
	Tai O Post Office	Tai O Government Building, Tai O, Lantau Island Tel : 2985 7333
	Cheung Chau Post Office	Cheung Chau Complex, G/F, 2 Tai Hing Tai Road, Cheung Chau Tel : 2981 0235
	Lamma Post Office	G/F, East & West, 2 Main Street, Yung Shue Wan, Lamma Island Tel : 2982 1260
	Peng Chau Post Office	Government Building, Wing On Street, Peng Chau Tel : 2983 0223

- (ii) **Manager (Retail Business/Kowloon)**
Address: M/F, Middle Road Car Park Building,
15 Middle Road, Tsim Sha Tsui, Kowloon
Tel : 2926 1169
Fax : 2312 1455

The District and Posting Offices for which the Manager (Retail Business/Kowloon) is responsible:

District	Posting Office	Address
Yau Tsim Mong	Kowloon Central Post Office	G/F, 405 Nathan Road, Yau Ma Tei Tel : 2928 6247
	Mong Kok Post Office	1/F, Mongkok Exchange, 37 Bute Street, Mong Kok Tel : 2380 3853
	Tsim Sha Tsui Post Office	G/F, Hermes House, 10 Middle Road, Tsim Sha Tsui Tel : 2366 4111
Kowloon City Wong Tai Sin	Gillies Avenue Post Office	G/F, 140 Gillies Avenue, Hung Hom Tel : 2362 2727
	Kowloon City Delivery Office	Hing Wah Centre, G/F, 82-84 Tokwawan Road, Kowloon City Tel : 2364 0463
Kwun Tong	Kowloon East Post Office	G/F, Kowloon East Government Offices, 12 Lei Yue Mun Road, Kwun Tong Tel : 2340 1539
	Kwun Tong Post Office	G/F, Kwun Tong District Branch Offices Building, 6 Tung Yan Street, Kwun Tong Tel : 2389 1920

- (iii) Manager (Retail Business/New Territories)
Address: 10/F, Tsuen Wan Government Offices,
Tsuen Wan, New Territories
Tel : 2417 6478
Fax : 2413 2853

The District and Posting Offices for which the Manager (Retail Business/New Territories) is responsible:

District	Posting Office	Address
Sham Shui Po	Cheung Sha Wan Delivery Office	G/F, Ka Ming Factory Building, 688 Castle Peak Road, Cheung Sha Wan Tel : 2741 4070
Tsuen Wan	Tsuen Wan Post Office	1/F, Tsuen Wan Government Offices, 38 Sai Lau Kok Road, Tsuen Wan Tel : 2417 6455
	Tsuen Wan West Post Office	Bayview Garden, 633 Castle Peak Road, Tsuen Wan Tel : 2417 0467
Kwai Tsing	Cheung Fat Post Office	Units 113-114, G/F, Chun Fat House, Cheung Fat Estate, Tsing Yi Tel : 2495 3822
	Lai King Post Office	G/F, Lok King House, Lai King Estate, Kwai Chung Tel : 2743 0482
Tuen Mun	Butterfly Post Office	Units 121-122, G/F, Tip Sum House, Butterfly Estate, Tuen Mun Tel : 2467 3268
	Tuen Mun Central Post Office	G/F Podium, Library and Post Office Building, 1 Tuen Hi Road, Tuen Mun Tel : 2441 3387
Yuen Long	Yuen Long Post Office	Shop B, G/F, 8 Yuen Long Pau Cheung Square, Yuen Long Tel : 2477 3037
North	Fanling Post Office	G/F, Fanling Government Offices Building, 3 Pik Fung Road, Fanling Tel : 2675 1689

District	Posting Office	Address
North (Cont'd)	Kam Tin Post Office	G/F, Kam Tin Government Offices Building, Kam Tin Main Road, Yuen Long Tel : 2476 2858
	San Tin Post Office	1A Castle Peak Road, San Tin Section, San Tin Tel : 2471 1107
	Sha Tau Kok Post Office	G/F, Sha Tau Kok Government Offices Building, Sha Tau Kok Main Road, Sha Tau Kok Tel : 2674 0670
	Shek Wu Hui Post Office	112-116 San Fung Avenue, Shek Wu Hui, Sheung Shui Tel : 2670 2282
Tai Po	Tai Po Post Office	G/F, Tai Po Government Offices Building, 1 Ting Kok Road, Tai Po Tel : 2650 8702
Sha Tin	Ma On Shan Post Office	Unit 2, G/F, Sunshine City Phase 4, 18 On Luk Street, Ma On Shan, Sha Tin Tel : 2633 3543
	Sha Tin Central Post Office	1/F, Sha Tin Government Offices, 1 Sheung Wo Che Road, Sha Tin Tel : 2697 9813
Sai Kung	Sai Kung Post Office	G/F, Sai Kung Government Offices Building, 34 Chan Man Street, Sai Kung Tel : 2792 2243
	Tseung Kwan O Post Office	Shop No. 9, Hau Tak Shopping Centre, Hau Tak Estate, Tseung Kwan O Tel : 2704 9644
Islands (Tung Chung)	Tung Chung Post Office	G/F, 6 Mei Tung Street, Tung Chung, Lantau Island Tel : 2109 0269

**Districts for Posting of Election Mail for
Geographical Constituencies**

Constituency	District	
	Name of District	District Code
Hong Kong Island	Central and Western	A
	Wan Chai	B
	Eastern	C
	Southern	D
Kowloon West	Yau Tsim Mong	E
	Sham Shui Po	F
	Kowloon City	G
Kowloon East	Wong Tai Sin	H
	Kwun Tong	J
New Territories West	Tsuen Wan	K
	Tuen Mun	L
	Yuen Long	M
	Kwai Tsing	S
	Islands	T
New Territories East	North	N
	Tai Po	P
	Sai Kung	Q
	Sha Tin	R

**Administrative Guidelines and Licensing Conditions
for the issue of Public Fund-raising Permits
for Non-Charitable Purposes**

Applications for permission under section 4(17) of the Summary Offences Ordinance (Cap.228) to raise funds by collection of money or sale of badges, tokens or similar articles or exchange the same for donations in a public place should, where the funds are to be used for a charitable purpose, be referred to the Director of Social Welfare. Where the funds are to be used for any other purpose, such applications should be referred to the Secretary for Home Affairs.

A. Administrative Guidelines for Consideration

When considering an application for a public fund-raising permit under section 4(17) of the Summary Offences Ordinance, the Secretary for Home Affairs will normally wish to be satisfied that : -

- (i) the organisation or group on behalf of which the permit is sought, and the organisation or group to benefit from the collection if different, are, where applicable, properly registered under the laws of Hong Kong;
- (ii) if the applicant is an individual, he should be aged 21 or above, and should either be a permanent resident of Hong Kong within the meaning of the Immigration Ordinance, or have been ordinarily resident in Hong Kong for a minimum of seven years;
- (iii) the funds collected will be used for purposes which would contribute directly or indirectly to the development of representative government in Hong Kong;
- (iv) the fund-raising activity will not cause public order and public safety problems, and will not cause nuisance or harassment to the general public;

- (v) the fund-raising activity should not be held on a morning which is a “flag day” approved by the Director of Social Welfare unless it is to be held in a confined public place;
- (vi) the fund-raising activity should not be held at the same time and in the same venue or its vicinity as a charitable fund-raising activity;
- (vii) there will be no more than one non-charitable fund-raising activity in the same venue or its vicinity on the same day except where the activities are organised by the same applicant;
- (viii) there will be a fair distribution of venues, dates and frequency of fund-raising among all potential applicants; and
- (ix) the permittee who had breached the conditions stipulated in the permit last granted would not be considered for a new permit unless explanations/justifications have been provided to the satisfaction of the Secretary for Home Affairs.

Each application will be considered on its own merits having regard to the above administrative guidelines.

B. Licensing Conditions

The following conditions will normally be imposed if an application is approved:

- (i) permission must have been obtained or is likely to be forthcoming from the relevant authorities, including the authority responsible for the management of the venue(s), for the fund-raising activity to be held;

- (ii) the funds collected will not be used to finance any profit-making ventures or activities;
- (iii) the funds collected will be used only in Hong Kong;
- (iv) no person will benefit improperly from the collection;
- (v) the permission given for the fund-raising activity is only valid for the details specified in the permit. If there are any changes to such details, the approval of the Secretary for Home Affairs will be required;
- (vi) the permission given for the fund-raising activity will become null and void if the funds collected are used for purposes other than those specified in the permit;
- (vii) within 90 days after the conclusion of the fund-raising activity, the permittee will cause the money received from the public, less any reasonable expenses incurred, to be applied for the purpose for which the permission is given;
- (viii) if after applying the funds collected as described in (vii) above, there is still a balance left, the permittee will donate the unspent funds to a charitable institution which is exempt from tax under section 88 of the Inland Revenue Ordinance (Cap.112) for charitable purpose;
- (ix) the funds collected will be audited by a qualified accountant arranged by the permittee. A copy of the audited accounts will be submitted to the Secretary for Home Affairs within 90 days after the conclusion of the fund-raising activity. The audited accounts will also be made available to members of the public for inspection upon demand;
- (x) all donations are to be purely voluntary, and that the activity shall not create public order problems or cause

nuisance, including excessive noise, or harassment to the general public, and that the manner in which the activity is conducted should not be such as to be likely to produce a reaction generally against public fund-raising activities;

- (xi) during the course of the fund-raising activity, the name of the organisation and a copy of the permit/approval letter should be prominently displayed. Every participant of the activity should also wear a clear and legible badge identifying the name of the participant and the name of the organisation; and
- (xii) children under the age of 14 must not be allowed to take part in the activity. Participation by young persons between the age of 14 - 18 must be entirely voluntary and the prior written consent of parents must be obtained.

The Secretary for Home Affairs may, if a particular application so warrants, impose additional conditions such as those required for the protection of the participants in the fund-raising event, for the preservation of law and order, for crowd control, or for public safety purposes. In specific circumstances, he may waive certain conditions where it appears reasonable for him to do so.

November 2003

**Application for a Permit under S4(17)
of Summary Offences Ordinance, Cap.228
for Non-Charitable Purposes**

This application should reach the Secretary for Home Affairs at 31/F, Southorn Centre, 130 Hennessy Road at least **FOUR WEEKS** before the date of the activity. This will enable the applicant to be notified of the result of his application about seven days before the event. For enquiries, please call 2835 1495.

1. Name of applicant : * Mr/Mrs/Miss/Ms _____

Name in Chinese (if any) : _____

2. Hong Kong Identity Card Number : _____

(Please enclose a photocopy of your Hong Kong Identity Card)

3. Address : _____

4. Contact Telephone No. : _____ Fax No. : _____

5. If this application is made on behalf of an organisation, please complete the following details : -

i) Name of organisation : _____

ii) Position of applicant in organisation : _____

iii) Details of key officers in organisation :

<u>Post</u>	<u>Name</u>	<u>Address</u>
<u>President/Chairman</u>	_____	_____

<u>Secretary</u>	_____	_____

<u>Treasurer/Accountant</u>	_____	_____

iv) Date the organisation was formed : _____

v) Type of organisation : Society registered/exempt under the Societies Ordinance, or
Company incorporated in Hong Kong, or
Others (Please give details)

(Please enclose a copy of the certificate of registration/exemption of your

organisation and also a copy of the memorandum and articles of association or the constitution or rules of your organisation whichever is applicable. If your organisation is a company incorporated in Hong Kong, a copy each of a Certificate of Incorporation and Certificate of Existence issued by the Companies Registry should also be produced.)

6. If the money raised is intended to benefit another organisation, please complete the following details : -

i) Name of organisation : _____

ii) Relationship between applicant and that organisation :

iii) Details of key officers in that organisation :

<u>Post</u>	<u>Name</u>	<u>Address</u>
<u>President/Chairman</u>	_____	_____

<u>Secretary</u>	_____	_____

<u>Treasurer/Accountant</u>	_____	_____

iv) Date the organisation was formed : _____

v) Type of organisation : Society registered/exempt under the Societies Ordinance, or
Company incorporated in Hong Kong, or
Others (Please give details)

(Please enclose a copy of the certificate of registration/exemption of the organisation and also a copy of the memorandum and articles of association or the constitution or rules of the organisation whichever is applicable. If the organisation is a company incorporated in Hong Kong, a copy each of a Certificate of Incorporation and Certificate of Existence issued by the Companies Registry should also be produced.)

vi) Has the organisation given consent to the activity being organised by you ? * Yes /
No

7. If the applicant is making this application as an individual, please complete the following details : -

i) Date and place of birth : _____

ii) Length of residence in Hong Kong : _____

iii) Are you a permanent resident of Hong Kong ? * Yes / No

8. ✦ Intended use of money to be collected : _____

9. ✦ Format of the activity : _____

10. ✦ Method for money collection : _____

11. ✦ Date and time of the activity listed in priority : _____

(Note : To ensure a fair distribution of venues, dates and frequency of fund-raising among all potential applicants, there could be a restriction on the number of days approved, depending on prevailing circumstances.)

12. ✦ Venue and address : _____

Has permission to use venue been secured ? * Yes / No / Under application / Not applicable

(If the venues are in open public places, please give exact locations and enclose layout plan. Please also indicate where furniture (e.g. table) will be placed, if appropriate.)

✦ If approval is given to this application, the permit issued will specify the details given in these items. It will therefore be to the applicant's own advantage to plan the activity carefully, so as to avoid the need to seek fresh approval later on as a result of any changes to the above details.

13. Details of previous S4(17) application(s) to the Secretary for Home Affairs by the applicant, or the organisations named in 5(i) and 6(i) above, or any of the persons named in 5(iii) and 6(iii) above :

<u>Name of Applicant</u>	<u>Date of Application</u>	<u>Approved or Rejected</u>
_____	_____	_____
_____	_____	_____
_____	_____	_____
_____	_____	_____

14. State here any additional information which the applicant wishes to provide in support of this application (e.g. reasons for requesting that the administrative guidelines or licensing conditions for the issue of permit be waived in whole or in part.)

I declare that to the best of my knowledge and belief, the information supplied by me in this form is true and correct.

Signed : _____
(Applicant)

(Chop of organisation, if applicable) Date : _____

* Delete where applicable

(If there is not enough space in this form for the filling in of the required information, the applicant may provide details on a separate sheet of paper and attach it to the form.)

Statement of Purpose

Purpose of Collection

1. The personal data provided by means of this form will be used by Home Affairs Department for the purpose of :

“To exercise functions on fund-raising activities for non-charitable purposes”

Classes of Transferees

2. The personal data you provided by means of this form may be disclosed to other Government bureaux, departments and relevant persons and bodies for the purposes mentioned in paragraph 1 above.

Access to personal data

3. You have a right of access and correction with respect to personal data as provided for in sections 18 and 22 and principle 6 of Schedule 1 of the Personal Data (Privacy) Ordinance. Your right of access includes the right to obtain a copy of your personal data provided by this form.

Enquiries

4. Enquiries concerning the personal data collected by means of this form, including the making of access and corrections, should be addressed to :

Administrative Officer
Home Affairs Department
Tel. No. : 2835 1495

November 2003

Fair and Equal Treatment of Candidates by the Print Media

1. Fairness and equality will in each case be viewed by the Electoral Affairs Commission with reference to the surrounding circumstances.
2. Practical problems that may be experienced by publishers like limitation of column space and staff resources, and situations such as some candidates who have extensive arguments and opinions on issues of public relevance and those who have none, candidates who have made newsworthy statements or speeches as opposed to those who have not uttered a word, and the difference in status and standing of candidates as public figures, etc, are examples of circumstances against which the criteria of fairness and equality are to be judged.
3. What is important is that practical problems, in general terms without specifics, should not be allowed to be used as pretexts for not giving fair and equal treatment and coverage to all candidates/Geographical Constituency (“GC”) lists of the same constituency. Merely saying that practical problems gave rise to the selective reporting will be viewed as a lame excuse, but if the other candidates/GC lists had been approached and they refused to offer any interview, and this fact is made known in the same article, there can hardly be any suspicion or complaint that the guidelines have been breached.
4. Equal treatment and coverage are not necessarily equal space and equal number of words written on each candidate/GC list of the same constituency. It is an idea that has to be examined in all the circumstances of each individual case. Where a candidate says more on a topic and another candidate says less, that can be truthfully and faithfully reported, and no reasonable-minded person will say that that is unequal reporting. Fairness and equality here are in the sense of **equal opportunity** being given to all candidates/GC lists of the same constituency alike.

5. If there is fair and equal treatment of all candidates/GC lists of the same constituency in a publication, its editorial line or the personal opinions of the writer on each of the candidates can be freely expressed, insofar as they are fair comments and based on true facts. Any newspaper is at full liberty to express its support for or disapproval of a candidate/GC list. The guidelines do not seek to impose any shackle on the expression of such ideas.

Application Procedure for the Approval of Float Design

1. All applications in respect of the design of any float to be used in a procession or parade must be made in writing, with the following particulars clearly stated:
 - the name of the applicant
 - the address of the applicant
 - contact telephone number and fax number
 - the make, model and registration mark (or vehicle identity number in the case of a brand new vehicle) of the vehicle to be used as float

2. The application should be accompanied by three copies of a drawing, certified by qualified electrical or mechanical engineers, in minimum A3 size, showing the following details:
 - the float and vehicle outline, side, plan, front and rear view, with all major dimensions (both proposed and original) shown
 - the means of entry/exit to and from the driver's compartment
 - location of mirrors which will enable the driver to view both sides of the float
 - location of exhaust outlets from any internal combustion engines
 - location of any auxiliary power equipment installed
 - means of communication with the passengers on the float
 - location of passengers and support for passengers (seats, handles, etc) on the float

Applicant's attention is drawn to regulation 53(2) of the Road Traffic (Traffic Control) Regulations on requirements for carriage of passengers: subject to subregulation (7), no driver of a vehicle on a road shall permit a passenger to travel in any vehicle unless seated in a properly constructed seat secured to

the bodywork of the vehicle except where the vehicle is a public service vehicle licensed to carry standing passengers.

- detailed artwork is not required
3. All applications must be made at least **one month** in advance of the date of the event to:

Engineer (Vehicle Approval and Planning)
Vehicle Safety and Standards Division
Transport Department
Room 3402, Immigration Tower
7 Gloucester Road
Hong Kong
(Contact telephone : 2829 5550
Fax : 2802 7533)

4. If the application is approved in principle (subject to the vehicle inspection results), the applicant will be so advised within 14 days upon the receipt of the application, and also informed of further details of the vehicle inspection.
5. In case the design is considered unacceptable, the applicant should resubmit revised drawings within one week's time upon notice.

**Canvassing Activities which are Forbidden within
a No Canvassing Zone**

(Note : (1) This list is by no means an exhaustive list of the canvassing activities which are prohibited within a no canvassing zone. It only serves to illustrate some of the common forms of canvassing activities.

(2) Door-to-door canvassing and for the purpose of such canvassing, the display of propaganda material, eg any badge, emblem, clothing or head-dress which may promote or prejudice the election of a candidate or candidates at the election, or makes direct reference to a body any member of which is standing as a candidate in the election or to a prescribed body which has given consent to its registered name or emblem to be printed on any ballot paper will be allowed on storeys above or below street level in a building other than a building in which there is a polling station provided that permission has been obtained for entry to the building for canvassing votes, obstruction is not posed to electors and no amplifying system or device is used.)

1. Unauthorised static display of election advertisements on walls (including the outer walls of the polling station), windows, railings, fences, etc.
2. Exhibition of portable displays on vehicles (whether in motion or parked within the area), or held or carried by persons.
3. Except for the purpose of door-to-door canvassing referred to in Note (2) above, displaying, without reasonable excuse, propaganda material eg any badge, emblem, clothing or head-dress which:
 - (a) may promote or prejudice the election of a candidate or candidates at the election; or

- (b) makes direct reference to a body any member of which is standing as a candidate in the election or a prescribed body which has given consent to its registered name or emblem to be printed on any ballot papers.
- 4. Distribution of election advertisements.
- 5. Canvassing for votes :-
 - (a) talking to electors;
 - (b) shouting slogans or the name or number of a candidate or any appeal message;
 - (c) singing or chanting; or
 - (d) making signals or signs to electors.
- 6. Broadcast of audio or video tape to appeal to or induce electors to vote.
- 7. Using loud-hailers or loudspeakers (whether carried by a person or mounted on a vehicle or installed in any other manner) to broadcast any message which appeals to or induce electors to vote.
- 8. Shaking hands with electors.

**Items of Expenses which may be
Counted towards Election Expenses**

(Note : This list is by no means an exhaustive list of items of expenditure which may be counted as election expenses. It only serves to illustrate the common items of such expenses.)

1. Fees and allowances, including travelling expenses, paid to agents and assistants engaged in relation to one's election activities.
2. Costs incurred for meals and drinks for agents and assistants before and on polling day.
3. Costs incurred for design and production of election advertisements such as :
 - (i) banners
 - (ii) signboards
 - (iii) placards
 - (iv) posters
 - (v) handbills
 - (vi) publicity pamphlets
 - (vii) video and audio tapes
 - (viii) electronic messages
 - (ix) various forms of literature or publicity material for the promotion of the candidate.
4. Costs incurred for display and removal of election advertisements including labour charges. If the election advertisements have not been removed by the deadline specified by the Electoral Affairs Commission, the removal costs for the election advertisements charged by the government departments should also be included.
5. Costs incurred by the relevant authorities for removal of election advertisements displayed without authorisation.
6. Costs incurred for renting space used in connection with the election campaign.
7. Cost of stationery used in connection with the election campaign.
8. Operation costs in connection with the election campaign, eg photocopying, hire of telephone line and fax line.
9. Postage for mailing of publicity materials (excluding the free mail

provided by the Government).

10. Costs incurred for the hire of transport in connection with the election.
11. Costs incurred for publicity by broadcasting vans.
12. Costs of advertisements in newspapers, taxi or other public transport.
13. Costs incurred for election meetings, including venue charges.
14. Costs of T-shirts, armbands, caps, etc and other identification devices for election agents and assistants.
15. Costs incurred by a candidate who is a serving member of the Legislative Council, a District Council, the Heung Yee Kuk, or a serving chairman, vice-chairman or member of the Executive Committee of a Rural Committee; or a serving village representative in the publication of performance reports during the election period (i.e. from the commencement of the nomination period to the close of poll) of the Legislative Council election and the publication of performance reports for promoting the candidature any time on or before the date of election.
16. Costs incurred by the political body or organisation of the candidate in promoting his election. [Costs of meeting where the platform of the political body or organisation is publicised without specific reference to the candidate will not be counted as election expenses.]
17. Costs for obtaining legal advice incurred in respect of the management of an election (eg where a candidate asks his lawyer to vet an election publicity pamphlet to make sure that statements contained in it do not amount to libel). [Costs for obtaining legal advice on the general application of the election law including what is “election expenses” and “donations” will not be an election expense.]
18. Interest incurred from a loan to finance the campaigning activities of a candidate. [In case of an interest-free loan, the interest waived should be declared as a donation and correspondingly as an election expense. A reasonable amount should be assessed by reference to the market interest rate.]
19. Subsidy of activities organised for promoting one’s candidature is a form of donation which is counted as election expense.
20. Although some people may not charge the candidate for the goods

supplied or work, labour and services rendered, a reasonable sum estimated for such charges, over any allowance or discount usually given to customers, is an election expense (which is correspondingly a donation made by these people).

21. Goods given incidental to the provision of voluntary service.
22. Charities undertaken for the purpose of promoting one's candidature.
23. Costs for any negative publicity launched against one's opponent.

Support Clean Elections

A Handbook by the ICAC

24-Hr ICAC Election Enquiry Hotline: 2920 6530

24-Hr ICAC Report Hotline: 25 266 366

ICAC Corporate Website: www.icac.org.hk

INTRODUCTION

The Elections (Corrupt and Illegal Conduct) Ordinance (ECICO) (Cap 554), enacted with an aim to upholding fairness and preventing corrupt and illegal conduct in elections, applies to all public elections including the Legislative Council elections. The Independent Commission Against Corruption (ICAC) is responsible for enforcing the ECICO. It has produced this Handbook which comprises a gist of the ECICO, a “Dos and Don’ts” checklist, a questions-and-answers section, and channels for lodging reports and enquiries with the ICAC. The Handbook serves to alert candidates, their election agents and helpers to the common pitfalls in elections so that they can take appropriate measures to avoid inadvertent infringement of the ECICO. Candidates, election agents and helpers, however, should note that this Handbook is intended to be a general reference only. They should refer to the original legislation and consult their legal advisers in case of doubt.

GIST OF THE ELECTIONS (CORRUPT AND ILLEGAL CONDUCT) ORDINANCE

The Elections (Corrupt and Illegal Conduct) Ordinance (Cap. 554) (ECICO) applies to the Legislative Council Elections and other elections as specified in the Ordinance. This Ordinance governs all conduct concerning an election, whether it is engaged before, during or after the election period, and whether it is engaged within Hong Kong or elsewhere.

The following is a gist of major provisions of the ECICO which relates to the management of electioneering activities for the reference of candidates, their election agents and helpers.

To facilitate easy reference, “●” denotes an offence or elaboration of provisions under the ECICO and interpretation of terms is given under “□” in the following gist.

(1) NOMINATION OF CANDIDATES

Bribing Candidates or Prospective Candidates (Sections 2, 7)

- It is an offence if a person corruptly offers an advantage to another person as an inducement or a reward for:
 - (1) that person's standing, not standing, or if that person has been nominated as a candidate, withdrawal of his candidature, or his not using the best endeavours to promote his election; or
 - (2) that person to get a third person to stand, not to stand, or if that third person has been nominated as a candidate, to withdraw the third person's candidature, or not to use the third person's best endeavours to promote the election of the third person.

- It is also an offence if a person corruptly solicits or accepts an advantage for the above conduct.

- It is also an offence if a person authorises another person, either expressly or by implication, to engage in the above conduct.

- "Candidate"
 - (1) means a person who stands nominated as a candidate at an election; and
 - (2) also means a person who, at any time before the close of nominations for an election, has publicly declared an intention to stand as a candidate at the election,and in relation to an election to return Members for a Legislative Council geographical constituency, includes a person who is one of a group of candidates.

- "Group of candidates"
 - (1) means the persons whose names appear on a list of candidates nominated for election to return Members for a Legislative Council geographical constituency, other than persons whose names have, in accordance with section 38 of the Legislative Council Ordinance (Cap. 542), been excluded from or struck out of such a list; and
 - (2) in relation to a time before the close of nominations for such an election also means those persons who have publicly declared their intention to stand for election as candidates whose names appear on such a list, but does not include persons who have also publicly revoked their declaration of intention to stand at the election.

- "Advantage" means any valuable consideration, gift, loan, office,

employment, contract, favour or service (other than voluntary service or the provision of entertainment), etc. However, it does not include an election donation if particulars of the donation are given in an election return that has been lodged with the Chief Electoral Officer.

- “Voluntary service” means any service provided free of charge to or in respect of any candidate at an election by a natural person, voluntarily and personally, in the person’s own time for the purpose of promoting the election of the candidate or prejudicing the election of another candidate.

Using or Threatening to Use Force or Duress against Candidates or Prospective Candidates (Section 8)

- It is an offence if a person uses or threatens to use force or duress against another person to induce him :
 - (1) to stand or not to stand as a candidate, or to withdraw his candidature; or
 - (2) to get a third person to stand or not to stand as a candidate, or to withdraw the third person’s candidature.
- It is an offence if a person uses or threatens to use force or duress against another person because the other person or the third person stood or did not stand as a candidate, or withdrew his candidature after having been nominated as a candidate.
- It is also an offence if a person authorises another person, either expressly or by implication, to engage in the above conduct.

Deceptive Behaviour Relating to Candidates and Prospective Candidates (Section 9)

- It is an offence if a person, by deception, induces another person :
 - (1) to stand or not to stand as a candidate, or to withdraw his candidature; or
 - (2) to get a third person to stand or not to stand as a candidate, or to withdraw the third person’s candidature.
- It is also an offence if a person authorises another person, either expressly or by implication, to engage in the above conduct.

Defacing or Destroying of Nomination Papers (Section 10)

- It is an offence if a person defaces or destroys a completed or partly completed nomination paper in order to prevent or obstruct another person from standing for election.

(2) ELECTIONEERING

Publication of False Statement that a Person Is or Is Not a Candidate (Section 25)

- It is an offence if a person knowingly publishes a false statement that:
 - (1) he or another person is a candidate at an election; or
 - (2) another person who has been nominated as a candidate is no longer a candidate at an election.
- It is an offence if a candidate knowingly publishes a false statement that he is no longer a candidate at an election.

Publication of False or Misleading Statements about a Candidate (Section 26)

- It is an offence if a candidate or a person publishes a materially false or misleading statement about a particular candidate or particular candidates for the purpose of promoting or prejudicing the election of the candidate or candidates at an election.
- Statements about a candidate or candidates include (but are not limited to) statements concerning the character, qualifications or previous conduct of the candidate or candidates.

Election Advertisement with False Claim of Support (Sections 2, 27)

- It is an offence if a candidate or a person publishes or authorises the publication of an election advertisement which includes the name or logo of or associated with a person or an organisation, or a name or logo that is substantially similar to that of a person or an organisation; or a pictorial representation of a person, in such a way that implies or causes electors to believe that the candidate or candidates have the support of the person or organisation unless prior written consent from that person or organisation has been obtained.
- It is still an offence even if such an election advertisement contains a

statement to claim that such inclusion does not imply support by the person or organisation concerned.

- It is an offence if a person purports to give written consent to the inclusion in an election advertisement of the name or logo of an organisation without having been approved by the governing body of the organisation or by a resolution of the members of the organisation passed at a general meeting.
- It is also an offence if a person, for the purpose of promoting or prejudicing the election of a candidate or candidates, knowingly gives materially false or misleading information to the candidate or candidates.
- “Support” includes support for the policies or activities of the candidate.
- “Election advertisement” means :
 - (1) a publicly exhibited notice; or
 - (2) a notice delivered by hand or electronic transmission; or
 - (3) a public announcement made by radio or television or by video or cinematographic film; or
 - (4) any other form of publication,
published for the purpose of promoting or prejudicing the election of a candidate or candidates at the election.

Publication of Election Advertisements that Do Not Meet Certain Requirements (Sections 33, 34)

- It is an offence if a person publishes a printed election advertisement, with exception to those printed in a registered local newspaper, which fails to show, in English or Chinese, the name and address of the printer, the date of printing and the number of copies printed.
 - The above conduct is, however, not an offence if the publisher, or a person authorised by him, has lodged with the relevant Returning Officer a statutory declaration on the required printing details not later than 7 days after the publication of the advertisement.
 - A person must, not later than 7 days after publishing a printed election advertisement, furnish 2 copies of the advertisement to the relevant Returning Officer.*
- * It should, however, be noted that under the Electoral Affairs Commission (Electoral Procedure) (Legislative Council) Regulation, a candidate must submit 2 copies of his election advertisement to the relevant Returning

Officer and comply with the other statutory requirements stipulated therein before he displays, distributes or otherwise uses the election advertisement.

- A performance report published by an incumbent candidate, who is the person holding office as a serving member of the Legislative Council, a District Council, or the Heung Yee Kuk; a serving Chairman, Vice-chairman or member of the Executive Committee of a Rural Committee; or a serving Village Representative, between the period beginning with the nomination day and ending with the polling day, is taken as an election advertisement.

(3) VOTING

Bribing Electors and Others (Section 11)

- It is an offence if a person, without reasonable excuse, offers an advantage to another person as an inducement to or a reward for that person or for him to get or try to get a third person :
 - (1) not to vote at an election; or
 - (2) to vote or not to vote for a particular candidate or particular candidates at an election.
- It is also an offence if a person, without reasonable excuse, solicits or accepts an advantage in return for the above conduct.
- It is also an offence if a person authorises another person, either expressly or by implication, to engage in the above conduct.

Providing Electors and Others with Refreshments or Entertainment (Section 12)

- It is an offence if a person provides, or pays for the provision of any food, drink or entertainment for another person as an inducement to or a reward for that person or a third person :
 - (1) not to vote at an election; or
 - (2) to vote or not to vote for a particular candidate or particular candidates at an election.
- It is an offence if a person solicits, accepts or takes any food, drink or entertainment as an inducement to or a reward for the above conduct.
- It is also an offence if a person authorises another person, either expressly or by implication, to engage in the above conduct.

- However, the serving of non-alcoholic drinks at an election meeting is not an offence.
- An election meeting is any meeting held to promote or prejudice the election of a particular candidate or particular candidates.

Using or Threatening to Use Force or Duress against Electors (Section 13)

- It is an offence if a person uses or threatens to use force or duress against another person to induce that person or to get him to induce a third person to vote or not to vote at an election; or to vote or not to vote for a particular candidate or particular candidates.
- It is an offence if a person uses or threatens to use force or duress against another person because the other person voted or refrained from voting at an election, or voted or refrained from voting for a particular candidate or particular candidates.
- It is also an offence if a person authorises another person, either expressly or by implication, to engage in the above conduct.

Deceptive Behaviour in Relation to Electors (Section 14)

- It is an offence if a person, by deception, induces another person or gets him to induce a third person not to vote at an election; or to vote or not to vote for a particular candidate or particular candidates.
- It is an offence if a person, by deception, obstructs or prevents another person or gets him to obstruct or prevent a third person from voting at an election.
- It is also an offence if a person authorises another person, either expressly or by implication, to engage in the above conduct.

Impersonating Another at Election (Section 15)

- It is an offence if a person unlawfully applies for a ballot paper in another person's name or, having voted at an election, applies at the same election for a ballot paper in his own name.

Other Offences with Respect to Voting (Section 16)

- It is an offence if a person :
 - (1) votes at an election knowing that he is not entitled to vote at that election; or
 - (2) votes at an election after having knowingly or recklessly given materially false or misleading information to an electoral officer, or knowingly omitted to give material information to an electoral officer; or
 - (3) votes at an election more than once except as expressly permitted by an electoral law.

- It is an offence if a person invites or induces another person :
 - (1) to vote at an election knowing that the other person is not entitled to do so; or
 - (2) to vote at an election knowing that the other person has given materially false or misleading information to an electoral officer, or has omitted to give material information to an electoral officer; or
 - (3) to vote at an election more than once except as expressly permitted by an electoral law.

Destroying or Defacing Ballot Papers (Section 17)

- It is an offence if a person, without lawful authority, supplies a ballot paper to another person, or destroys or interferes with a ballot box or ballot paper in use at an election or a ballot paper that has been used at an election.
- It is an offence if a person, with intent to deceive, puts into a ballot box a paper other than a ballot paper or removes a ballot paper from a polling station.

(4) ELECTION EXPENSES AND ELECTION DONATIONS

Election Expenses (Sections 2, 24)

- “Election expenses” means expenses incurred or to be incurred before, during or after the election period, by or on behalf of a candidate or group of candidates for the purpose of :
 - (1) promoting the election of the candidate or group; or
 - (2) prejudicing the election of another candidate or group,and includes the value of election donations consisting of goods and services used for that purpose.

- A candidate commits an offence if the aggregate amount of the election

expenses whether incurred by or on behalf of the candidate exceeds the prescribed maximum amount of election expenses. In the list system of voting, each member of a group of candidates commits an offence if the aggregate amount of the election expenses exceeds the prescribed maximum amount of the election expenses.

- The maximum amount of election expenses for each constituency in the 2004 LegCo Election is as follows:

Constituency	Prescribed Limit
(a) for a GC election	i. \$1,500,000 for a list in Kowloon East and Kowloon West GCs ii. \$2,000,000 for a list in Hong Kong Island GC iii. \$2,500,000 for a list in New Territories East and New Territories West GCs
(b) for an election for one of the following 4 special FCs, viz, Heung Yee Kuk, Agriculture and Fisheries, Insurance, and Transport FCs	\$100,000
(c) for an election for an FC other than those in (b) above with not more than 5,000 registered electors	\$160,000
(d) for an election for an FC with between 5,001 and 10,000 registered electors	\$320,000
(e) for an election for an FC with over 10,000 registered electors	\$480,000

Use of Election Expenses (Sections 2, 23)

- It is an offence if a person, other than a candidate or a candidate's election expense agent, incurs any election expenses.
- It is an offence for a candidate who belongs to a group of candidates to incur election expenses unless he has been authorised by each other candidate of the group to be their election expense agent. Similarly, an election expense agent must obtain the authorisation from all candidates of the group before incurring election expenses.

- An “election expense agent” means a person authorised in writing by a candidate or a group of candidates to incur election expenses on behalf of the candidate or the group of candidates, with the maximum amount of election expenses to be incurred by him being specified in the authorisation, a copy of which has been served on the relevant Returning Officer.
- It is an offence if a candidate does not include election expenses incurred by the candidate or the candidate’s election expense agent in the candidate’s election return.
- It is an offence for an election expense agent to incur election expenses that exceed the amount specified in his authorisation.

Use and Disposal of Election Donations (Sections 2, 18, 19)

- “Election donation” means :
 - (1) any money given to a candidate or candidates for the purpose of meeting the election expenses of the candidate or candidates; or
 - (2) any goods (including any goods given incidental to the provision of voluntary service) or service (excluding voluntary service) provided to a candidate or candidates for the purpose of promoting the election of the candidate or candidates or of prejudicing the election of another candidate or other candidates.
- It is an offence if a candidate or other person uses election donations for a purpose other than :
 - (1) meeting the candidate’s election expenses; or
 - (2) promoting the election of the candidate or prejudicing the election of another candidate.
- It is an offence if a candidate, on receiving an election donation of more than \$1,000, does not issue a receipt to the donor.
- It is an offence if a candidate uses an anonymous election donation of more than \$1,000 for meeting or contributing towards meeting his election expenses.
- It is also an offence if a candidate does not give an anonymous election donation of more than \$1,000 to a charitable institution or trust of a public character chosen by the candidate.
- It is an offence if a candidate does not give the unused election donations or donations that exceed the prescribed maximum amount of election expenses

to a charitable institution or trust of a public character chosen by the candidate.

Election Returns (Sections 20, 36, 37, 38)

- It is an offence if a candidate knowingly makes a materially false or misleading statement in the election return.
- It is an offence if a candidate fails to lodge with the Chief Electoral Officer an election return of his election expenses and all election donations not later than 60 days after the date of publication of the result of the election, or after the declaration of the termination of the election proceedings or the failure of the election under the relevant electoral law.
- The return must be accompanied by:
 - (1) an invoice and a receipt of each election expense, giving particulars of the expenditure (except for sums under \$100);
 - (2) a copy of the receipt issued to every donor, giving particulars of the donor and the donation (except for donations of \$1,000 or below);
 - (3) a copy of the receipt of such election donation given to a charitable institution or trust of a public character by the candidate in accordance with the law;
 - (4) an explanation setting out the reason why the unused election donation was not disposed of in accordance with the law; and
 - (5) a declaration in a form provided or specified by the Chief Electoral Officer verifying the contents of the return.

(5) ELECTION PETITION OR ELECTION APPEAL

Bribery in Relation to Election Petition or Election Appeal (Section 21)

- It is an offence if a person offers an advantage to another person:
 - (1) as an inducement for that person, or for him to get a third person, to withdraw an election petition or election appeal; or
 - (2) as a reward for that person for his having withdrawn or agreed to withdraw; or for his having got a third person to withdraw an election petition or election appeal.
- It is an offence if a person solicits or accepts an advantage:
 - (1) to withdraw or as an inducement to withdraw an election petition or election appeal; or
 - (2) as a reward for his having withdrawn or his having got a third person to

withdraw an election petition or election appeal.

(6) MISCELLANEOUS AND RELATED PROVISIONS

Corrupt or Illegal Conduct Engaged in with the Knowledge and Consent of a Candidate (Section 29)

- A candidate is to be regarded as having personally engaged in corrupt or illegal conduct if the conduct was engaged in with the knowledge and consent of the candidate.

Officers Liable for Offences Committed by Corporation (Section 42)

- If a corporation is found guilty of having engaged in a corrupt or illegal conduct, the director, executive officer or any person who is concerned in the management of the corporation during the material time will be liable for the conduct unless the person proves that:
 - (1) he has no knowledge of the conduct; or
 - (2) he has exercised reasonable diligence to prevent the conduct, if it was done with his knowledge.

Aiding, Abetting, etc. to Commit an Offence (Section 43 of the ECICO and Section 101C of the Criminal Procedure Ordinance)

- A person commits an offence if he incites, conspires with, aids, abets, counsels or procures another person or attempts to engage in a corrupt or illegal conduct.

(7) APPLICATION FOR RELIEF

Relief for Certain Illegal Conduct (Section 31)

- A candidate, agent or any other person who has done or omitted to do an act that would be an “illegal conduct” under the ECICO may apply to the Court for an order relieving him from penalties and disqualifications to be imposed on him.
- The applicant has to satisfy the Court that such act or omission was due to inadvertence, an accidental miscalculation or any reasonable cause and was not due to bad faith.

Relief for Offences in Relation to Election Advertisements (Section 35)

- Any person who has published a printed election advertisement without the printing details required by the legislation or has not furnished 2 copies of the printed election advertisement to the relevant Returning Officer may apply to the Court for an order:
 - (1) allowing the publication be excepted from the statutory requirements;
 - (2) relieving him from penalties to be imposed on him.
- The applicant has to satisfy the Court that the non-compliance was due to inadvertence, an accidental miscalculation or any reasonable cause and was not due to bad faith.

Relief for Offences in Relation to Election Returns (Section 40)

- A candidate who fails to lodge an accurate election return before the end of the permitted period, or fails to send an invoice or a receipt, or a copy of a receipt, as required by the law may apply to the Court for an order allowing the candidate to lodge with the Chief Electoral Officer an election return within such further period as the Court specifies, or an order enabling the candidate to correct any error or false statement in an election return, or an order excepting the candidate from the requirement to send an invoice or a receipt, or a copy of a receipt, as required by the law.
- The candidate has to satisfy the Court that the failure to comply with the requirement was attributable to the following reasons and was not due to bad faith:
 - (1) the applicant's illness or absence from Hong Kong *; or
 - (2) the death, illness, absence from Hong Kong of an agent or employee of the applicant *; or
 - (3) misconduct of an agent or employee of the applicant; or
 - (4) inadvertence or an accidental miscalculation or an accidental loss or destruction of the invoice or receipt or copy of the receipt by the applicant or any other person; or
 - (5) any reasonable cause.

- * (1) and (2) are considerations only applicable to court orders granting an extended period during which a candidate may lodge an election return, but not applicable to court orders enabling a candidate to correct any error or false statement in an election return, or excepting the candidate from the requirement to send an invoice or a receipt, or a copy of receipt.

(8) PENALTY

Corrupt Conduct

- As stipulated in the ECICO, a person who engages in corrupt conduct at an election commits an offence and is liable on conviction to:
 - (1) a fine of \$200,000 and imprisonment for 3 years if tried summarily; or
 - (2) a fine of \$500,000 and imprisonment for 7 years if tried on indictment.
- A person who is convicted of having engaged in corrupt conduct has to pay to the Court the amount or value of any valuable consideration received in connection with the conduct or such part as specified by the Court.

Illegal Conduct

- As stipulated in the ECICO, a person who engages in illegal conduct at an election commits an offence and is liable on conviction to:
 - (1) a fine at level 5 and imprisonment for 1 year if tried summarily; or
 - (2) a fine of \$200,000 and imprisonment for 3 years if tried on indictment.
- A person who has contravened the provisions of Section 34 or 37 of the ECICO is liable on conviction to the same penalty as illegal conduct, except that a contravention of Section 34 is not subject to the following disqualifications.

<p>Corrupt conduct refers to that mentioned in Sections 7, 8, 9, 10, 11, 12, 13, 14, 15, 16, 17, 18, 19, 20 and 21 of the ECICO as listed in this Handbook, whereas illegal conduct in Sections 23, 24, 25, 26 and 27.</p>
--

Disqualifications

- A person convicted of an offence (except for contravention of Section 34 or 39) under the ECICO will be :
 - disqualified from being registered as an elector or voting in the Chief Executive, Legislative Council, District Councils or Village Representative elections for 3 years from the date of conviction;
 - disqualified from being nominated as a candidate for the election of, or elected as the Chief Executive, a member of the Legislative Council and a District Council or a Village Representative for 5 years from the date of conviction; or
 - disqualified from being nominated as a candidate for the election of, or elected or nominated as an Election Committee member for 3 years from the date of conviction.

Immediate Custodial Sentence

- According to the sentencing guideline set by the Court of Appeal on 27 November 1997, any person convicted of a serious election-related offence shall receive an immediate custodial sentence in order to uphold clean and fair elections in Hong Kong.

DOS AND DON'TS CHECKLIST

Candidates, their election agents and helpers should note the following in an election:

(1) NOMINATION OF CANDIDATES

Bribing Candidates or Prospective Candidates

- * Do not offer any advantage to get any person to stand or not to stand as a candidate.
- * Do not offer any advantage to get any person having been nominated as a candidate to withdraw his candidature.
- * Do not authorise another person, either expressly or by implication, to offer advantage for getting any person to engage in the above conduct.
- * Do not solicit or accept any advantage for any person's standing or not standing as a candidate.
- * Do not solicit or accept any advantage for any person's withdrawal of his candidature.

Deception

- * Do not induce by deception, any person to stand or not to stand as a candidate, or to withdraw his candidature.

Nomination Paper

- * Do not deface or destroy any nomination paper to prevent or obstruct another person from standing for an election.

(2) ELECTIONEERING

Statements about a Candidate

- * Do not knowingly publish any false statement that a person is or is not a candidate.
- * Do not make any materially false or misleading statement of fact including

but not limited to the character, qualifications or previous conduct of a candidate or candidates.

Election Advertisement

- ★ Do not use, without obtaining prior written consent, the name or logo of a person or an organisation; or the pictorial representation of any person in an election advertisement in such a way as to infer that the candidate concerned has the support of the named person or organisation.
- ★ Do include in all printed election advertisements the name and address of the printer, the date of printing and the number of copies printed except those printed in a registered local newspaper.
- ★ Do remember that a performance report published by an incumbent candidate between the nomination day and the polling day of the election is taken as an election advertisement.
- ★ Do furnish 2 copies of the election advertisement to the relevant Returning Officer not later than 7 days after publishing a printed election advertisement #.
- # It should, however, be noted that under the Electoral Affairs Commission (Electoral Procedure) (Legislative Council) Regulation, a candidate must submit 2 copies of his election advertisement to the relevant Returning Officer and comply with the other statutory requirements stipulated therein before he displays, distributes or otherwise uses the election advertisement.

(3) VOTING

Bribery

- ★ Do not offer any advantage to induce any person not to vote at an election.
- ★ Do not offer any advantage to induce any person to vote or not to vote for a particular candidate at an election.
- ★ Do not authorise another person, either expressly or by implication, to offer advantage for getting any person to engage in the above conduct.

Providing Refreshments or Entertainment

- ★ Do not provide or pay for the provision of any food, drink or entertainment

as an inducement to or a reward for any person's not voting at an election.

- * Do not provide or pay for the provision of any food, drink or entertainment as an inducement to or a reward for any person's voting or not voting for a particular candidate at an election.
- * Do not authorise another person, either expressly or by implication, to provide any food, drink or entertainment for getting any person to engage in the above conduct.

Using or Threatening to Use Force or Duress

- * Do not use or threaten to use force or duress against any person for the purpose of influencing his or any other person's voting decision.
- * Do not authorise another person, either expressly or by implication, to engage in the above conduct.

Engaging in Deceptive Behaviour

- * Do not induce by deception any person not to vote at an election.
- * Do not induce by deception any person to vote or not to vote for a particular candidate at an election.
- * Do not authorise another person, either expressly or by implication, to engage in the above conduct.

Other Offences in Relation to Voting

- * Do not deface or destroy any ballot paper unless lawfully authorised.
- * Do not knowingly invite or induce ineligible persons to vote.
- * Do not induce a person to vote more than once in the same constituency.

(4) ELECTION EXPENSES AND ELECTION DONATIONS

Election Expenses

- ✳ Do not incur election expenses more than the prescribed maximum amount of the election expenses for each constituency.
- ✳ Do not incur election expenses unless you are a candidate or a candidate's election expense agent with the required authorisation. In the list system of voting, an election expense agent must obtain the authorisation from all candidates of the group before incurring election expenses.
- ✳ Do not incur election expenses in excess of the amount authorised by the candidate or group of candidates if you are an election expense agent.
- ✳ Do include the election expenses incurred by the candidate and his election expense agents in the election return.

Election Donations

- ✳ Do not use election donations on activities unrelated to an election.
- ✳ Do issue a receipt for any election donation of more than \$1,000.
- ✳ Do send any election donation of more than \$1,000 received from an anonymous donor to a charitable institution or trust of a public character chosen by the candidate.
- ✳ Do send any unused election donations and donations in excess of the statutory limit of election expenses to a charitable institution or trust of a public character chosen by the candidate.

Election Returns

- Do submit a return on election expenses and donations to the Chief Electoral Officer not later than 60 days after the date of publication of the result of the election, or after the declaration of the termination of the election proceedings or the failure of the election under the relevant electoral law.
- ✳ Do submit with your election return the invoices, receipts and declaration form as stipulated by the law.
- ✳ Do not knowingly make any materially false or misleading statement in the return on election expenses and donations.

- * Do lodge your election return with the Chief Electoral Officer even if **NO** election expense is incurred.

(5) ELECTION PETITION OR ELECTION APPEAL

- * Do not offer any advantage to induce any person to withdraw an election petition or election appeal.
- * Do not solicit or accept any advantage to withdraw an election petition or election appeal.

QUESTIONS AND ANSWERS

Q1. The professional organisation to which a candidate of a LegCo FC Election belongs will arrange an overseas field trip for its members this summer. The candidate plans to actively canvass for votes from these members during the trip. He has also prepared a travel kit containing a leaflet expounding on his election platforms for all the participants as gifts. Will he contravene the ECICO by so doing?

- A1.
- It is an offence under S.11 of the ECICO for a person to offer an advantage to another person for the latter to vote or not to vote for a particular candidate or particular candidates at the election, or not to vote at the election. An “advantage” as defined in the Ordinance refers to any item of valuable consideration. While a candidate is free to employ any tactics for promoting his candidature, he, however, will commit the above offence if he distributes items of monetary value to his electors with a view to inducing the latter to vote for him during his electioneering campaign.
 - The candidate must note that S.5 of the ECICO applies to all conduct concerning an election, whether the conduct is engaged in within Hong Kong or elsewhere. S.6 and S.22 of the ECICO also stipulate that a person may be convicted of an offence under the Ordinance if he is found to have engaged in corrupt or illegal conduct before, during or after the election period. As such, the above-mentioned candidate should have been caught by S.11 of the ECICO, no matter when the act takes place and whether it is engaged within Hong Kong or elsewhere. Whether an offer of advantage to electors is an offence depends on the purpose and not the time and place of the offer.
 - He should also note that the expenses incurred for the procurement of the travel kit and the leaflet have to be counted towards his election expenses.

Q2. An incumbent LegCo member launched a personal website to update electors on his performance in the constituency at regular intervals after the 2000 LegCo Election. He will stand for the 2004 LegCo Election. Will the production and operation cost of this website be counted as his election expenses? If he creates another online forum for surfers to express their views on the forthcoming LegCo Election, should he count the cost incurred by this forum towards his election expenses?

- A2.
- Any incumbent LegCo member can create his own website to report to his constituent his work and services. He, however, should note that if the website is also used for promoting his candidature in the forthcoming LegCo Election, it will be regarded as his election advertisement (EA). The cost required for creating and operating the website will have to be counted as his election expenses.
 - Performance report issued by an incumbent candidate during the election period is regarded as an EA under S.34 (9) of the ECICO. As such, the above website will be an EA once the LegCo member becomes a candidate of the next LegCo Election, no matter whether the website has promoted his forthcoming election or not. The operation cost of the website incurred from this moment onwards should be counted towards his election expenses.
 - If the said online forum is created solely for providing a discussion forum for surfers to express their views on the coming LegCo Election without promoting the election of any candidate at all, the cost for creating and running the platform will not be counted as election expenses.

Q3. Several candidates on a GC list intend to introduce their election platforms and aspirations to electors through a letter and an electronic mail (email) in their joint names for enlisting support. What should they take note of in order not to breach the ECICO?

- A3.
- Under the ECICO, any form of notice including a letter or an email which serves the purpose of promoting or prejudicing the election of a candidate is an election advertisement (EA). Any person publishing a printed EA is required to abide by S.34 of the ECICO. He has to include in the printed EA, in English or Chinese, the name and address of the printer, the date of printing and the number of copies printed. He should also furnish two copies of the printed EA to the appropriate Returning Officer not later than seven days after publishing it. In addition, the publisher should also take heed of the requirements for EAs as stipulated in the Electoral Affairs Commission (Electoral Procedure) (Legislative Council) Regulation (EAC (EP) (LC) Reg) and the Guidelines on Election-related Activities in respect of the LegCo Elections issued by the EAC. For example, the EAC (EP) (LC) Reg requests a candidate to deposit two copies of all EAs with the relevant Returning Officer before the EAs are published.

- Since both the letter and email are joint EAs of the candidates on a GC list, the expenses incurred for publishing them including the cost of paper, envelopes, postages and internet charges, etc. should be shared by the candidates concerned. All candidates on the same GC list, on the other hand, should have authorised each other to be their respective election expense agents before incurring any election expense for the group in accordance with S.23 (2) of the ECICO.

Q4. Candidate A of a LegCo GC Election wishes to include in his election advertisement (EA) a photograph he took with another Candidate B of a LegCo FC Election to show the latter's support to him. Is it necessary for Candidate B to share the election expenses incurred for the said EA? What should Candidate A do if the information about B appearing on his EA is subsequently found to be incorrect?

- A4.
- Whether candidate B is required to bear the election expenses incurred for the said EA depends on different circumstances.
 - As defined in the ECICO, an EA is any publicity material published for the purpose of promoting or prejudicing the election of a candidate. If the EA in question serves to promote the elections of both candidates (A and B), it will be regarded as their joint EA, and in this connection, they will be required to share the election expenses involved.
 - If the EA simply shows Candidate B's support to Candidate A, there will be no need for Candidate B to share the expenses incurred for producing the EA. Candidate A, however, should have obtained B's prior written consent as required by S.27 of ECICO before he publishes the EA.
 - Candidate A should take immediate action to amend any mistakes/omissions found in his EA. If the EA has been released, he should try his best to withdraw it. Candidate A should also include all the expenses for the production and subsequent correction, etc. in his election expenses.

Q5. Two candidates who are in keen competition within the same constituency intend to organise negative publicity against each another. Which provisions of the ECICO should they abide by? If an election banner used by a candidate for prejudicing the election of his opponent is defaced, should the cost for repairing or reproducing a new banner be counted as his election expenses?

- A5.
- The ECICO has not laid down any restrictions on the format of election campaign arranged by a candidate. That includes any negative publicity for a candidate to prejudice the election of another candidate. He, however, should make sure that all statements of fact published about a particular candidate must be true. Otherwise, he will breach S.26 of the ECICO which prohibits any person, including a candidate, from publishing a materially false or misleading statement of fact concerning (but not limited to) a candidate's character, qualifications or previous conduct for the purpose of promoting or prejudicing the election of a candidate.
 - Since it is obvious that the negative publicity carried out by a candidate is to promote his election and prejudice that of his opponent, the cost for the negative publicity should be counted towards the candidate's election expenses.
 - The cost incurred for repairing/recreating or re-producing the defaced banner used for prejudicing the election of his opponent should also be included in the election expenses of the candidate concerned.

Q6. Is it an offence if a person has incurred election expenses on behalf of a candidate without obtaining his prior written authorisation? Can the said person claim that the expenses incurred are election donations to be given to the candidate? Will he still be caught by the ECICO if the candidate eventually agrees to accept the "donations"?

- A6.
- Under S.23 of the ECICO, only the candidate or persons authorised by him in writing may incur election expenses. Such an authorisation will become effective only after a copy of it has been served on the relevant Returning Officer.
 - It is therefore an offence for the said person to have incurred election expenses without the candidate's prior written authorisation or before the authorisation has been served on the relevant Returning Officer. There is no subsequent action which can remedy the offence once an election

expense has been incurred. Even if the items purchased or services rendered were subsequently donated to the candidate, this would not alter the fact of the commission of the offence.

- The expenditure so incurred should be accounted for both as an election expense and as a donation.

Q7. Is it against the ECICO for a main contractor to request a sub-contractor of his firm to vote for a LegCo FC Election candidate he supports?

- A7.
- S.13 of the ECICO makes it an offence for a person to use or threaten to use force or duress against another person with a view to inducing or compelling the latter to vote for a particular candidate at an election.
 - Although it is difficult to define whether such a request will amount to “force” or “duress” as it will depend on the circumstances of each case, persons who are in positions of influence should be wary of their conduct which may cross the line between legitimate lobbying in support of a candidate and effecting a duress against others to vote in a particular way.

Q8. Is it legal for a candidate to arrange free bus transportation to take electors to the polling station?

- A8.
- Provision of free bus transportation service falls within the definition of “advantage” as stipulated in S.2 of the ECICO. Whether the provision of such a service free of charge will contravene the ECICO depends on the circumstances under which the service is provided.
 - There should be no offence under the ECICO if the bus transportation service is provided by any person, including a candidate solely to facilitate electors to go to the polling stations for voting with no canvassing activities whether to promote or prejudice any particular candidate or candidates being carried out in the vehicle engaged for providing the bus transportation service mentioned.
 - The situation, however, will be different if canvassing activities are carried out in the vehicle for promoting any particular candidate. The display of election posters or advertisements or the presence of his agents wearing clothing or accessories making reference to a particular candidate or candidates in the vehicle, etc. obviously are canvassing activities.

Expenses incurred in this connection should therefore be counted towards the election expenses of the candidate(s) concerned. The free transportation service provided may, under the circumstances, be regarded as an advantage offered to induce electors to vote for the candidate. Hence, those who provide the bus transportation service are likely to have contravened S.11 of the ECICO.

- According to the said provision, a person who, without reasonable excuse, offers an advantage to another person as an inducement to or a reward for that person not to vote at an election, or to vote or not to vote for a particular candidate or particular candidates, will be guilty of an offence. Along the same line, a person will commit an offence if he accepts an advantage for the above purposes.

Q9. Will an elected candidate of a LegCo Election be liable to an offence if he hosts a dinner party for and sends thank-you letters to election helpers who have supported his election? Should the expenses incurred by the dinner party and letter be counted towards his election expenses? Will it make any difference if the above expenses are not borne by the candidate himself?

- A9.
- The candidate has nothing to worry about if the dinner party and the thank-you letters are arranged for the purpose of marking the inauguration of his term as a LegCo member since the purpose of hosting the said dinner party and sending the letters is not for promoting his election. In the circumstances, the expenses incurred, whether they are borne by the candidate himself or not, need not be counted towards his election expenses.
 - In the case of the dinner party, if it is hosted to honour the candidate's promise made previously to the participants that they would be rewarded with a dinner party for their electioneering assistance upon the candidate's successful election, the hosting of this dinner party is related to the purpose of promoting his election and the expenses of the dinner party should be counted towards the candidate's election expenses. If the expenses of the dinner party are borne by the participants, the amount should be regarded as election donations to the candidate and be included in his election return.
 - If the dinner party is hosted as a reward for the participants' having voted for the candidate, both the candidate and the participants have contravened S.12 of the ECICO.

Q10. Is it necessary for a complainant to produce evidence to the ICAC while lodging a complaint against any conduct in contravention of the ECICO? Will the complainant be accused of making a malicious report in the event that the report is not substantiated?

- A10.
- Any person who suspects any conduct in contravention of the ECICO is welcome to make a report to the ICAC. We will investigate each pursuable complaint to ascertain whether such malpractice exists.
 - Any person who wishes to make a report to the ICAC can contact any of the eight ICAC Regional Offices and its 24-hour Report Centre direct. He can also lodge the complaint by calling the ICAC Report Hotline (Tel: 25 266 366) or writing to Hong Kong GPO Box 1000.
 - The ICAC welcomes reports on suspected corruption from the public. However, if a person knowingly furnishes false information for misleading ICAC officers, he will commit an offence under S.13B of the ICAC Ordinance and will be liable to a maximum penalty of 1 year's imprisonment and a fine of \$20,000.
 - Any candidate or member of the public who wishes to make enquiries on the ECICO may call the 24-hour ICAC Election Enquiry Hotline (Tel: 2920 6530), or approach any ICAC Regional Office.

CHANNELS FOR REPORTS AND ENQUIRIES

REPORTS

Any person who discovers or suspects any conduct in contravention of the ECICO may call the 24-hour ICAC Report Hotline 25 266 366, or make a report in person to any ICAC Regional Office, or write to Hong Kong GPO Box 1000.

ENQUIRIES

Any person who wishes to make enquiries on the ECICO may call the 24-hour ICAC Election Enquiry Hotline 2920 6530, or approach any ICAC Regional Office from 9:00 a.m. to 6:00 p.m. Monday to Friday and 9:00 a.m. to 1:00 p.m. on Saturday (except public holidays).

ADDRESSES AND TELEPHONE NUMBERS OF ICAC REGIONAL OFFICES

HONG KONG ISLAND

ICAC Regional Office (Hong Kong West/Islands)

G/F, Harbour Commercial Building
124 Connaught Road Central, Sheung Wan
Tel: 2543 0000

ICAC Regional Office (Hong Kong East)

G/F, Tung Wah Mansion
201 Hennessy Road, Wanchai
Tel: 2519 6555

KOWLOON

ICAC Regional Office (Kowloon West)

G/F, Nathan Commercial Building
434-436 Nathan Road, Yau Ma Tei
Tel: 2780 8080

ICAC Regional Office (Kowloon Central)

G/F, 21E Nga Tsin Wai Road

Kowloon City

Tel: 2382 2922

ICAC Regional Office (Kowloon East/Sai Kung)

Shop No.4, G/F, Kai Tin Building

67 Kai Tin Road, Lam Tin

Tel: 2756 3300

NEW TERRITORIES

ICAC Regional Office (New Territories South West)

G/F, Foo Yue Building

271-275 Castle Peak Road, Tsuen Wan

Tel: 2493 7733

ICAC Regional Office (New Territories North West)

G/F, No. 4-5, North Wing Trend Plaza

Tuen Shun Street, Tuen Mun

Tel: 2459 0459

ICAC Regional Office (New Territories East)

G06-G13, G/F, Shatin Government Offices

1 Sheung Wo Che Road, Shatin

Tel: 2606 1144

支持同意書

Consent of Support

(填妥後請盡快存案於選舉主任)

(To be deposited with the Returning Officer as soon as it is completed)

適用於個人 For an individual

1. 我同意以下候選人：

I hereby give consent to the following candidate(s):

** 候選人姓名

** 香港身份證號碼

** Name of candidate(s)

** Hong Kong Identity Card No.

- | | | |
|----|-------|-------|
| 1. | _____ | _____ |
| 2. | _____ | _____ |
| 3. | _____ | _____ |
| 4. | _____ | _____ |
| 5. | _____ | _____ |
| 6. | _____ | _____ |

可依照《選舉（舞弊及非法行為）條例》第 27 條的規定，以我的 * 個人名義 / 職銜名義“_____”使用我的姓名或標識或跟我有關聯的姓名或標識或我的圖像，以示支持 * 他 / 她 / 他們在_____ [日期]舉行的立法會_____ * 地方選區 / 功能界別選舉中參選，藉以宣傳或協助 * 他 / 她 / 他們在選舉中獲選。

to use my name or logo of or associated with me or my pictorial representation in *my personal capacity/in my official capacity as “_____” in the manner described in section 27 of the Elections (Corrupt and Illegal Conduct) Ordinance, as an indication of my support, for the purpose of promoting or procuring *his / her / their election *as a member to the Legislative Council for the _____ Constituency at an election to be held on _____ [Date].

2. # 我已在_____ [組織名稱] 於_____ [日期]_____ [時間]舉行的大會中，獲准同意支持上述候選人。

I have obtained the approval of _____ [name of organisation] for my giving of the above consent at the general meeting of the organisation held on _____ [Date] at _____ [Time].

適用於組織 For an organization

3. * 我獲_____ [組織名稱] 授權，同意以下候選人：

I have been authorised by _____ [Name of organisation] to give consent to the following candidate(s)

** 候選人姓名

** 香港身份證號碼

** Name of candidate(s)

** Hong Kong Identity Card No.

- | | | |
|----|-------|-------|
| 1. | _____ | _____ |
| 2. | _____ | _____ |
| 3. | _____ | _____ |
| 4. | _____ | _____ |
| 5. | _____ | _____ |
| 6. | _____ | _____ |

可依照《選舉（舞弊及非法行為）條例》第 27 條的規定，使用該組織的名稱或標識（包括圖片及照片）或跟該組織有關的名稱或標識（包括圖片及照片），以示支持 * 他 / 她 / 他們在 _____ [日期]舉行的立法會 _____ * 地方選區 / 功能界別選舉中參選，藉以宣傳或協助 * 他 / 她 / 他們在選舉中獲選。

to use the name or logo of or associated with the organization in the manner described in section 27 of the Elections (Corrupt and Illegal Conduct) Ordinance, as an indication of its support, for the purpose of promoting or procuring *his / her / their election *as a member to the Legislative Council for the _____ Constituency at an election to be held on _____ [Date].

4. # 有關同意支持上述候選人的決議，已在組織於 _____ [日期] _____ [時間]舉行的大會中通過。

A resolution to give the above consent has been passed at the general meeting of the organization held on _____ [Date] at _____ [Time].

個人 / 組織均須填寫 For completion in both cases

5. * 我 / 本組織從以下候選人 :

*I/The organisation *have/has been given to understand by the following candidate(s):

** 候選人姓名

** 香港身份證號碼

** Name of candidate(s)

** Hong Kong Identity Card No.

- | | | |
|----|-------|-------|
| 1. | _____ | _____ |
| 2. | _____ | _____ |
| 3. | _____ | _____ |
| 4. | _____ | _____ |
| 5. | _____ | _____ |
| 6. | _____ | _____ |

處得悉，根據《立法會條例》第 39 條或同條例附表 2 第 14 條的規定，* 他 / 她 / 他們並沒有喪失獲提名為候選人的資格。

that *he/she/they *is/are not disqualified from being nominated as a candidate under section 39 of the Legislative Council Ordinance or section 14 of Schedule 2 to the same Ordinance.

由**候選人簽署 —

SIGNED BY CANDIDATE ** --

簽署 :
Signature : _____

簽署 :
Signature : _____

候選人姓名 :
Name of Candidate : _____

候選人姓名 :
Name of Candidate : _____

香港身份證號碼 :
HKID Card No. : _____

香港身份證號碼 :
HKID Card No. : _____

日期 :
Date : _____

日期 :
Date : _____

簽署 :
Signature : _____

簽署 :
Signature : _____

候選人姓名：
Name of Candidate : _____

香港身份證號碼：
HKID Card No. : _____

日期：
Date : _____

簽署：
Signature : _____

候選人姓名：
Name of Candidate : _____

香港身份證號碼：
HKID Card No. : _____

日期：
Date : _____

由同意人士 / 組織簽署 —
SIGNED BY --

簽署: _____
Signature

姓名: _____
Name

香港身份證號碼: _____
HKID Card No.

個人身分 / 職銜名義: _____
Capacity

組織蓋章: _____
Chop of organization

日期: _____
Date

候選人姓名：
Name of Candidate : _____

香港身份證號碼：
HKID Card No. : _____

日期：
Date : _____

簽署：
Signature : _____

候選人姓名：
Name of Candidate : _____

香港身份證號碼：
HKID Card No. : _____

日期：
Date : _____

由下列人士見證 —
WITNESSED BY –

簽署: _____
Signature

姓名: _____
Name

香港身份證號碼: _____
HKID Card No.

日期: _____
Date

備註
Note

- * 請刪去不適用者
Delete as appropriate.
- ** 如書面同意是向超過一位候選人（例如地方選區選舉某份候選人名單上的候選人）發出，請列出所有有關候選人的名字及身份證號碼；否則，可就每位候選人使用一張同意書。
If there is more than one candidate to whom consent is given, such as the candidates on a list of candidates in a geographical constituency election, set out all the names and identity cards numbers of all the candidates. Alternatively, use a separate form for each candidate.
- # 如支持某候選人的同意書是以組織名義，或是以組織主席／執行委員的職銜名義所發出，是項必須填寫。
To be completed where consent of support is given to a candidate in the official capacity of an office bearer of an organization, should the organisation consider necessary.

你須注意下列有關填報個人資料的說明 —

You may wish to note the following with regard to the personal data supplied in this form.

- (a) 資料用途
此表格內的個人及其他有關的資料，會供選舉事務處作選舉有關的用途。支持同意書亦會供公眾查閱。在展示支持同意書前，表格中所有香港身份證號碼將會被遮蓋。

Purpose of Collection

The personal data and other related information supplied in this form will be used by the Registration and Electoral Office and the Returning Officer for election related purposes. The consent form will also be made available for public inspection and all Hong Kong Identity Card Numbers provided in the form will be covered before the form is displayed.

- (b) 資料轉介
有關資料可能會提供給其他獲授權處理該等資料的部門或機構，以用作選舉有關的用途。

Classes of Transferees

The information provided in this form may also be provided to departments /agencies authorized to process the information for election related purposes.

- (c) 索閱個人資料
任何人有權根據《個人資料（私隱）條例》內所載的條款要求索閱及修訂所提供的個人和其他有關資料。

Access to Personal Data

Any person has a right to request access to, and to request the correction of, the personal data which he/she provided in accordance with the provisions of the Personal Data (Privacy) Ordinance.

- (d) 查詢

有關透過本表格收集的個人資料的查詢、包括索閱及修正個人資料，應向總選舉事務主任（地址：香港灣仔港灣道 25 號海港中心 10 樓）提出。

Enquiry

Enquiries concerning the personal data collected by means of this form, including the making of access and corrections, should be addressed to the Chief Electoral Officer at 10th Floor, Harbour Centre, 25 Harbour Road, Wan Chai, Hong Kong.

選舉管理委員會

Electoral Affairs Commission

2004 年 7 月

July 2004

Guidelines for Mutual Aid Committees

1. Chapter 18 of the Electoral Affairs Commission's Guidelines on the Legislative Council Elections provides that a candidate must obtain the prior written consent from a person or an organisation before using the name or logo of that person or organisation, or a pictorial representation of that person in any of his election advertisements or activities as an indication of support from that person or organisation.

2. In this respect, Mutual Aid Committees ("MACs") should comply with the following procedures:

- (a) If the support is to be given to a candidate or a list of candidate(s) of a geographical constituency ("GC list") in the name of the MAC, the written consent should be approved at a general meeting convened in accordance with the Model Rules for the MAC, and signed by the incumbent Chairman of the MAC.
- (b) If the support to a candidate/GC list is to be given in the official capacity of an office bearer of a MAC, that office bearer should first obtain the approval of the MAC at a general meeting convened in accordance with the Model Rules for the MAC. Otherwise, that office bearer should be careful not to give any impression or cause misunderstanding that the support in his official capacity represents the support of the MAC.
- (c) If the support to a candidate/GC list is to be given in the personal capacity of an office-bearer of the MAC and his official title will not be mentioned in the election advertisements of the candidate/GC list, it will not be necessary for that office-bearer to seek approval from the MAC or its executive committee.

3. All general meetings of the MAC should be convened in accordance with the procedures laid down in the Model Rules for the MAC.

4. Decisions taken at the meetings of MACs must be properly recorded and the record must be prominently displayed in the block within seven days after the meeting.

Index

(The numbers indicate paragraph numbers)

a

- action checklist for candidates 1.18, Appendix A
- actors, during election period 11.10
- address, change of an elector's residential address 2.12, 3.21
- admission
 - counting station (see also *counting station*) 5.49-5.50, 5.52, 7.14, 7.43-7.44
 - polling station (see also *polling station*) 5.18-5.19, 7.14, 7.26-7.28
- advance return of donations (see also *donation*) 16.25, 16.27-16.29, 16.57
- advertising
 - through the electronic media 8.1-8.2, 8.44, 8.47-8.49
 - through the printing media 8.56, 11.13-11.15
- agent
 - counting (see *counting agent*)
 - election (see *election agent*)
 - election expense (see *election expense agent*)
 - polling (see *polling agent*)
- allocation of designated spots (see *designated spots* under *election advertisement*)
- allocation of polling station (see also *polling station*) 5.4, 5.10-5.11, 7.34
- amplifying device (see *loudspeaker*)
- anonymous donations (see *donation*)
- appeal against provisional register (see also *provisional register*) 2.18, 3.26
- application for registration as an elector (see also *elector*) .. 2.4-2.5, 2.8-2.10, 3.5-3.11, 3.14, 3.17-3.19
- appointment
 - counting agent (see also *counting agent*) 7.39-7.40
 - election agent (see also *election agent*) 7.7-7.9
 - election expense agent (see also *election expense agent*) 7.15-7.17, 16.10
 - polling agent (see also *polling agent*) 7.22-7.23
- Arabic numeral (see also *ballot paper*) 5.29, 5.66-5.67
- assistance to incapacitated elector (see also *disability of electors* and *elector*) 5.11, 5.25, 5.37, 7.34-7.36
- authorisation of election expense agent (see also *election expense agent*) 7.15-7.17, 16.10-16.11, 16.13
- authorised representative (AR)
 - eligibility for appointment 3.12-3.13

authorized representative (AR) (*Cont'd*)
- notice of appointment.....3.14

b

badge, emblem, clothing or head-dress (see also *propaganda material*).....5.16-5.17,
5.38, 7.31, 7.37, 8.2, 8.44, 14.9

ballot box

- colour.....5.8, 5.14
- delivery.....5.47, 5.53, 5.63, 7.29
- locking and sealing
 - at the close of poll.....5.42, 5.44-5.45, 5.47, 5.53, 5.63, 7.29-7.30
 - before commencement of poll.....5.12, 7.29-7.30
- opening.....5.45, 5.53, 5.63, 7.45

ballot paper

- colour.....5.7, 5.15
- counting.....5.48-5.72
- disposal.....5.76-5.78
- invalid.....5.54-5.57, 5.66-5.67
- marking.....5.28-5.30, 5.32, 5.34, 5.37, 7.36
 - Arabic numeral.....5.29, 5.66-5.67
 - chop.....5.27-5.29, 5.56-5.57, 5.66-5.67, 7.36
- questionable.....5.54-5.60, 5.62, 5.66-5.67
- removal from polling station.....Note under 5.31
- spoiled.....5.34, 5.42, 5.56, 5.66, 7.29
- tendered.....5.35, 5.56, 5.66, 7.29
- unissued.....5.13, 5.42-5.45, 5.47, 7.29
- unused.....5.25-5.26, 5.36, 5.42, 5.56, 5.66, 7.29
- validity.....5.54-5.58, 5.66-5.69

ballot paper account.....5.54-5.55, 5.64

breach/non-compliance of Guidelines.....1.21, 8.62, 10.38-10.39, 11.19, 12.9, 13.10,
15.11, 16.52, 17.30, 17.33, 20.1, 20.4, 20.14

bribery (see also *corrupt conduct*).....2.6, 3.15, 4.5, 16.27, 17.5, 17.18

broadcasting van (see also *loudspeaker*).....12.4, 12.6-12.7

by-election (see also *Legislative Council* and *election*).....1.2, 1.18-1.19

c

candidate

- action checklist..... 1.18, Appendix A
- appearing in commercial advertisements..... 11.11-11.12
- attending public functions..... 19.8
- definition..... Important Note under 8.1, Important Note under 11.1, 16.2,
Important Note under 19.1
- disqualification..... 4.5-4.6
- false statement (see also *false statement*)..... 17.8-17.9
- incumbent candidates (see *incumbent candidates*)
- lodging of complaint inside polling station..... 7.38, 20.9
- nomination (see *nomination of candidates*)
- qualification..... 4.2-4.4
- withdrawal..... 4.18, 4.24, 4.36

canvassing activities

- in no canvassing zone..... 5.3, 5.16-5.17, 7.37, 12.8, 14.2, 14.9-14.11,
14.13-14.14, 14.16, 15.5, Appendix K
- involving pupils..... 13.1-13.9
- joint canvassing..... 8.34
- outside a polling station (see also *polling station*)... 5.16-5.17, 12.8, 14.9-14.14
- using loudspeaker (see *loudspeaker*)
- using vehicles..... 12.4, 12.6-12.7

cardboard

- colour..... 5.7, 5.9, 5.27

censure (see also *reprimand*)

- breach of time restriction when using loud-hailers..... 10.31, 12.4
- breach/non-compliance of Guidelines..... 1.21, 8.62, 10.38-10.39, 11.19, 12.9,
13.10, 15.11, 16.52, 17.30, 17.33, 20.1, 20.4, 20.14
- corrupt and illegal conduct..... 17.33
- exit poll..... 15.11
- false claim of support..... 17.33, 18.14
- involving youths of school age..... 13.2, 13.10
- namedropping..... 17.33, 18.14
- opportunity to make representations..... 20.14
- unauthorised display of election advertisements..... 8.62
- unauthorised electioneering against the decision of an organisation or building
..... 10.27-10.28
- unfair and unequal treatment..... 10.19, 10.38-10.39, 11.19

central counting station (see also <i>counting station</i>)	5.1, 5.43, 5.45, 5.47-5.49, 5.53, 5.62-5.63, 5.74-5.75, 7.29, 7.40-7.41
change of an elector's particulars (see also <i>provisional register</i>)	
- other personal particulars (see also <i>elector</i>)	2.14-2.15, 3.23
- residential address (see also <i>elector</i>)	2.12-2.13, 2.15, 3.21-3.23
Chief Electoral Officer (CEO) (see also <i>Registration and Electoral Office</i>)	
- authorising other form of delivery of nomination form to RO	4.20
- authorising public officers to enter polling or counting station	5.18, 5.49
- deciding display of election advertisement outside the constituency in which a candidate stands	8.31
- designating polling and counting stations	5.2, 5.11
- keeping sealed packets of documents for safe custody	5.77
- reporting irregularities to EAC	20.11, 20.17
chop (see also <i>ballot paper</i>)	5.27-5.29, 5.56-5.57, 5.66-5.67, 7.36
claim of support	8.2, 8.35, 8.46, 17.10-17.14, 18.1-18.14
close of poll	5.42-5.47, 14.6, 15.6
combined polling arrangements	5.5-5.11
- colour cardboard	5.6-5.7, 5.9, 5.27
- poll card	5.6-5.7, 5.10
commercial advertisements, candidates appearing in	11.11-11.12
common parts of building (see also <i>fair and equal treatment principle</i>)	8.32, 10.3-10.4, 10.6-10.7, 10.11, 10.14, 10.17-10.18, 10.21, 10.33
complaints	
- against conduct, behaviour or acts of RO or REO officers	20.5
- against criminal, illegal or corrupt activities	20.2
- containing false statement (see also <i>false statement</i>)	20.18
- duties of PROs, Deputy PROs, Assistant PROs, ROs and REO	20.10-20.11, 20.17
- hotline	20.7
- inside polling station	7.38, 20.9-20.10
- obligations of the RO, PRO and the REO	20.17
- period	20.6
- procedure	20.7-20.10
- processing	20.11-20.15
- relating to breach of Guidelines or Regulation	8.62, 17.30, 20.1, 20.4
- relating to display of election advertisements	8.62, 20.14
- report to Chief Executive	20.16

Complaints Committee.....	10.28-10.29, 10.34, 20.3-20.5, 20.9, 20.11-20.13, 20.15, 20.17-20.18
conduct at	
- counting station (see also <i>counting agent</i> and <i>counting station</i>).....	5.49-5.52, 7.43-7.46
- polling station (see also <i>polling agent</i> and <i>polling station</i>).....	5.20-5.41, 7.30-7.32
consent of support (see also <i>namedropping</i>).....	8.49, 17.10-17.14, 18.1-18.14
corrupt and illegal conduct	
- election expenses and donations.....	7.9, 7.13, 7.20, 8.64, 8.66, 16.9-16.10, 16.13, 16.54-16.59, 17.22, 17.26
- electioneering and voting.....	17.8-17.25
- handbook (see also <i>ICAC, Handbook</i>).....	17.2, Appendix M
- non-compliance and sanction (see also <i>censure</i> and <i>reprimand</i>).....	17.30-17.35
- penalty.....	17.4, 17.34
- power of court to excuse innocent acts.....	17.27-17.29
corrupt conduct	
- bribery.....	2.6, 3.15, 4.5, 16.27, 17.5, 17.18
- deception.....	17.5-17.6
- deface of nomination paper.....	17.7
- duress.....	17.5-17.6, 17.23-17.24
- election expenses and donations.....	16.55, 16.57, 17.22, 17.26
- force.....	Important Note under 4.36, 5.33, 17.5-17.6, 17.23-17.24
- nomination and withdrawal of candidates.....	17.5-17.7
- penalty.....	17.4, 17.33-17.34
- treating.....	9.3, 17.19-17.22
- voting offences.....	17.25
corruption, ICAC handbook (see also <i>ICAC, Handbook</i>).....	17.2, Appendix M
counting, rules relating to.....	5.34-5.36, 5.53-5.72
counting agent	
- appointment.....	7.39-7.40
- conduct inside counting station.....	5.49-5.52, 7.43-7.46
- number.....	7.4
- qualification/civil servants acting as agents.....	7.5-7.6
- revocation.....	7.41
- role.....	7.42
counting of votes	
- presence.....	5.49-5.50

counting of votes (<i>Cont'd</i>)	
- process.....	5.53-5.75
- re-count of votes.....	5.62, 5.72
counting staff.....	5.48-5.49
counting station	
- admission.....	5.49-5.50, 5.52, 7.14, 7.43-7.44
- central counting station.....	5.1, 5.43, 5.45, 5.47-5.49, 5.53, 5.62-5.63 5.74-5.75, 7.29, 7.40-7.41
- conduct inside (see also <i>conduct at</i> and <i>counting agent</i>).....	5.49-5.52, 7.43-7.46
- conversion of polling station to counting station (see also <i>polling station</i>).....	5.1, 5.43, 5.48, 7.29
- designation.....	5.1-5.2
- display of notice of opening of counting station.....	5.48
- display of notice of result (see also <i>result</i>).....	5.74-5.75
- main counting station.....	5.2, 5.47, 5.54-5.55
- photographing, filming and recording.....	5.51
- public area.....	5.49-5.50
- public observation.....	5.49-5.50
counting zone.....	5.49, 5.51, 5.58, 5.64-5.65
Court of First Instance.....	6.3, 16.26, 17.29
court, power to excuse innocent acts.....	17.27-17.29

d

date	
- allocation of number to candidates by drawing of lots.....	4.59
- appeal against provisional register.....	2.16, 2.18, 3.24, 3.26
- application for re-allocation of polling station by elector with a disability..	5.11
- application for registration as electors.....	2.9, 3.18
- application period of NACs (see also <i>Nominations Advisory Committees</i>)	4.8, 4.14
- deadline for postage-free election advertisement to reach addressees before polling day.....	8.80
- election or polling.....	1.2
- elector's notice of change of particulars to reach ERO.....	2.15, 3.23
- nomination.....	4.16
- publication of final registers.....	2.19, 3.27
- publication of provisional registers and omission lists.....	2.16-2.17, 3.24-3.25

date (<i>Cont'd</i>)	
- sending in material for inclusion in introductory leaflet	4.60
- sending poll card	5.10
- suggestions of designated spots to reach CEO	Note under 8.17
declaration	
- election advertisement (see also <i>election advertisement</i>)	8.46, 8.51-8.54
- for using free postage	8.84
- result of election (see also <i>result</i>)	2.26-2.27, 3.32-3.33, 5.73-5.75
Declaration of Secrecy	
- counting station	5.50, 7.43-7.44
- polling station	5.19, 7.27-7.28, 7.31
delivery of ballot box (see also <i>ballot box</i>)	5.47, 5.53, 5.63, 7.29
delivery of return and declaration of election expenses and donations (see also <i>return and declaration of election expenses and donations</i>)	16.23
deposit, consent of support (see also <i>consent of support</i>)	8.49, 17.10-17.11, 18.7, 18.13
deposit, election	4.22-4.24
deposit, election advertisement with RO (see also <i>election advertisement</i>)	8.49, 8.58, 17.16-17.17
deposit, permission or authorisation to display election advertisement (see also <i>election advertisement</i>)	8.18, 8.23, 8.29, 8.49
designated spots for displaying election advertisement (see <i>election advertisement</i>)	
designation of	
- no canvassing zone (see also <i>no canvassing zone</i>)	5.3, 5.16, 14.3-14.4
- no staying zone (see also <i>no staying zone</i>)	5.3, 5.16, 14.3-14.4
- polling and counting station (see also <i>polling station</i> and <i>counting station</i>)	5.1-5.2, 5.4, 5.11
disability of electors (see also <i>elector</i>)	
- marking of ballot paper	5.37, 7.35
- re-allocation of polling station	5.11, 7.34
- template (see <i>template</i>)	
dismounting of election advertisement (see also <i>election advertisement</i>)	8.43
display of election advertisement (see <i>election advertisement</i>)	
disposal of documents and ballot papers	5.76-5.78
disposal of donation (see also <i>donation</i>)	16.17, 16.19, 16.24
disqualification	
- candidate (see also <i>candidate</i>)	4.5-4.6

disqualification (<i>Cont'd</i>)	
- elector (see also <i>elector</i>)	2.6, 3.15
- voting	2.6, 3.15
distribution of election advertisement (see also <i>election advertisement</i>)	8.3-8.5, 8.46-8.47, 8.49, 10.1, 17.10

donation	
- advance return	16.25, 16.27-16.29, 16.57
- anonymous	16.19
- definition	16.3
- disposal	16.17, 16.19, 16.24
- in kind	16.16, 16.18, 16.20-16.22
- purpose	16.3, 16.14-16.15
- receipt	16.19, 16.25
- return (see <i>return and declaration of election expenses and donations</i>)	

drawing of lots	
- allocation of alphabet or number to candidate	4.37, 4.59
- allocation of designated spots	8.22, 8.28, 8.30
- allocation of venue for conducting election meeting	9.17
- determination of election result	2.24-2.25, 3.30-3.31, 5.74

e

election	
- by-election (see also <i>Legislative Council</i>)	1.2, 1.18-1.19
- date	1.2
- declaration of result	2.26-2.27, 3.32-3.33, 5.73-5.75
- general election (see also <i>general elections</i>)	1.2, 1.18-1.19, 2.2, 3.2, 4.8, 4.14, 4.57-4.58

election advertisement (EA)	
- corrective declaration	8.51
- declaration	8.46, 8.51-8.54
- definition	8.1-8.4
- deposit with RO	8.49, 8.58, 17.16-17.17
- designated spots	8.13-8.17, 8.22-8.23, 8.25-8.28, 8.30, 8.32
- allocation	8.21-8.23, 8.26-8.28
- outside the constituency in which a candidate stands	8.31
- re-allocation	8.30
- suggestions by prospective candidates	8.17

election advertisement (EA) (*Cont'd*)

- dismantling..... 8.43
- distribution..... 8.3-8.5, 8.46-8.47, 10.1, 17.10
- joint display..... 8.32
- joint declaration and submission..... 8.50
- mailing
 - free postage
 - addressing..... 8.76-8.79
 - conditions..... 8.67-8.69
 - list of posting offices..... 8.80-8.82, Appendix F
 - make-up..... 8.70-8.75
 - method of folding..... 8.74, Appendix E
 - posting arrangement..... 8.80-8.87
 - segregation of letters..... 8.83, Appendix G
 - size..... 8.69, 8.73
 - weight..... 8.69
- mounting and installation..... 8.37-8.42
- negative campaigning..... 16.11
- no-display areas..... 5.16, 8.24-8.25
- penalty..... 8.23, 8.57-8.62
- performance report..... 8.3-8.5
- permission/authorisation of display..... 8.12, 8.18, 8.23, 8.29, 8.49, 8.59
- prejudicing a candidate..... 8.7-8.8
- print media..... 8.56, 11.13-11.15
- printed election materials..... 8.55-8.56, 17.15-17.17
- printing details..... 8.49, 8.55, 8.57-8.58
- private spots..... 8.13, 8.18, 8.46, 10.21-10.22
- public inspection..... 8.54
- published materials by organisations..... 8.63-8.66
- quantity..... 8.10
- removal..... 8.39-8.40, 8.43, 8.51, 8.60
- re-use of old publicity boards..... 8.35
- serial numbering..... 8.44-8.46
- size..... 8.36, 8.44-8.45, 8.69, 8.73
- unauthorised display and consequence..... 8.60, 14.10

election agent

- appointment..... 7.7-7.9
- lodging of complaint inside polling station..... 7.38, 20.9

election agent (*Cont'd*)

- number.....7.4, 7.7
- qualification/civil servants acting as agents.....7.5-7.6
- revocation.....7.10-7.11
- role.....7.13-7.14

election broadcasting

- election advertisements.....11.2
- equal time principle.....11.3, 11.5-11.8
- fair and equal treatment.....11.8
- no unfair advantage principle.....11.4-11.8
- participation by candidates.....11.9-11.12
- restrictions on presenters, regular contributors, actors, musicians, singers or other entertainers who are candidates.....11.9-11.10

election campaigning.....9.5, 9.11, 9.19, 11.4, 11.14, 11.17, 12.9, 13.9, 16.11

election day (see also *date*).....1.2

election deposit

- amount.....4.22
- payment.....4.19, 4.22-4.23
- return.....4.24

election donation (see *donation*)

election expenses

- corrupt and illegal conduct (see also *corrupt and illegal conduct, corrupt conduct* and *illegal conduct*).....7.9, 7.13, 7.20, 8.64, 8.66, 16.9-16.10, 16.13, 16.54-16.59, 17.22, 17.26
- definition.....8.9, 16.2, 16.4
- items also counted.....7.17-7.18, 8.18, 8.43, 8.61, 8.63, 8.66, 8.86, 9.2 10.37, 16.5, 16.22, 17.21, Appendix L
- liability of a candidate.....7.9, 7.20, 16.9, 16.13, 16.23, 16.53
- maximum amount.....8.10, 16.7-16.9
- return (see *return and declaration of election expenses and donations*)
- special features applicable to a GC list.....16.44-16.49
- who may incur.....7.9, 7.13, 7.15, 8.63-8.64, 16.10, 16.47

election expense agent

- appointment.....7.15-7.17, 16.10
- authorisation.....7.15-7.17, 16.10-16.11, 16.13
- cross-authorisation by candidates on a GC list.....7.15-7.17, 16.47-16.48
- illegal conduct.....7.19-7.20, 16.54
- number.....7.4, 7.15

election expense agent (<i>Cont'd</i>)	
- qualification/civil servants acting as agents	7.5-7.6
- revocation	7.18
- role	7.19, 16.10
election forums	9.1, 11.9, 11.15-11.18
election meeting	
- at private premises	9.5, 9.8, 9.15-9.18
- definition	9.1
- in a public place	9.6-9.10
- liability of candidates	9.4
- notification to the Police	9.6-9.9
- responsibility of organiser	9.10
election petition	6.1-6.3
electioneering activities	
- at government premises	10.9
- at private premises	10.1
- declaration to management body	10.26
- identification of canvassers	10.37
- management bodies	10.1, 10.10, 10.17-10.26, 10.36
- management company	10.6, 10.17-10.26
- mutual aid committee	10.7, 10.17-10.26
- notification of decision to RO	10.36
- owners committee	10.5-10.6, 10.17-10.26
- owners corporation	10.3-10.6, 10.12-10.14, 10.17-10.26
- owners' right	10.3-10.4, 10.14
- residents association	10.7, 10.17-10.26
- sanction	10.38-10.39
- tenants association	10.7, 10.17-10.26
- tenants' right	10.12-10.14
- corrupt and illegal conduct (see also <i>corrupt and illegal conduct</i> , <i>corrupt conduct</i> and <i>illegal conduct</i>)	17.8-17.25
- in public housing estates	8.26, 9.17, 9.19, 10.34-10.35
- in schools	13.8-13.9
- participated by school pupils (see also <i>pupil involvement</i>)	13.2-13.8
- scope	10.1
- using loud-hailers (see also <i>loudspeaker</i>)	12.2-12.8
electioneering on TV and radio (see <i>election broadcasting</i>)	

elector

- application for registration 2.4-2.5, 2.8-2.10, 3.5-3.11, 3.14, 3.17-3.19
- change of other personal particulars 2.14-2.15, 3.23
- change of residential address 2.12-2.13, 2.15, 3.21-3.23
- corporate elector 3.7-3.8, 3.12-3.14, 3.16, 3.24, 5.5, 5.11, 5.29, 5.35, 15.8
- disqualification 2.6, 3.15
- eligibility to vote 2.3, 3.4
- identification at polling station 5.21
- qualification for registration
 - as a FC elector 3.5-3.11
 - as a GC elector 2.4-2.5
- roll-over
 - as a FC elector 3.16
 - as a GC elector 2.7
- visual deficiency 5.37, 7.35-7.36
- with a disability 5.11, 5.25, 5.37, 7.34-7.36

Electoral Registration Officer (ERO)

- change of personal particulars 2.12-2.15, 3.21-3.23
- publishing final register 2.3, 2.19, 3.27
- publishing provisional register and omissions list 2.16-2.18, 3.24-3.26
- registration of electors 2.5, 2.9-2.10, 3.6, 3.18-3.19

eligibility

- nomination of candidates (see *nomination of candidates*)
- to vote 2.3, 3.4

empty opaque bag 2.25, 3.31, Annex to Appendix C

enlarged copy of introductory leaflet (see *introductory leaflet*)

entertainers, during election 11.10

entrance intercom system 10.30, 10.32

equal number of first preference votes 3.29, Appendix C

equal time principle 11.3, 11.5-11.8, 11.16

exit poll

- application 15.3
- approval 15.4
- identification of interviewers 15.9-15.10
- restrictions 14.13, 15.5-15.6
- sanction (see also *censure* and *reprimand*) 15.11
- secrecy of the vote 15.8
- time for publication of result 15.6

f

fair and equal treatment principle

- common parts of building 10.17-10.18, 10.21, 10.33
- display of election advertisement at private premises .. 8.19, 10.17-10.18, 10.21
- election forums 11.16-11.18
- electioneering activities at private premises 10.1, 10.9, 10.17-10.18
- electioneering activities in schools 13.9
- electronic media 11.3-11.12
- print media 11.14-11.15, Appendix I
- sanction (see also *censure* and *reprimand*) 10.28, 10.38-10.39, 11.19, 13.10

false claim of support 17.10-17.14, 18.1-18.15

false statement

- about a candidate 17.8-17.9
- about a complaint 20.18
- in return and declaration of election expenses and donations 16.57
- of withdrawal of candidature 17.8
- penalty 16.57, 16.59, 17.34

filming inside

- counting station (see also *counting station*) 5.51
- polling station (see also *polling station*) 5.41

final register

- abuse or misuse of information Important Note under 2.19,
Important Note under 3.27
- contents 2.19, 3.27
- date of publication 2.19, 3.27
- inclusion of an elector's name 2.9-2.19, 3.18-3.27
- inspection 2.19, 3.27
- reflection of changes of electors' particulars 2.19, 3.27
- validity 2.19, 3.27

Financial Assistance Scheme

- amount payable 16.30-16.33
- making claims and submission 16.34-16.37
- payment of claims after verification 16.42
- recovery of payment 16.43
- verification of claims 16.38-16.40
- withdrawal of claims 16.41

first past the post system

- application 1.6, 3.28

first past the post system (*Cont'd*)

- drawing of lots.....3.30-3.31
- equality of votes.....3.30-3.31
- invalid vote.....5.66
- marking of ballot papers.....5.29, 7.36
- mechanism.....3.30-3.33

float design.....12.7, Appendix J

force or duress (see also *corrupt conduct*).....Important Note under 4.36, 5.33,
17.5-17.6, 17.23-17.24

form

- advance return of donations.....16.25, 16.28
- authorisation for display/distribution of election advertisements or
electioneering activities at private premises.....8.18
- consent of support.....18.1, 18.12, Appendix N
- corrective declaration of election advertisements.....8.51
- declaration for posting of election communication.....8.84
- declaration of election advertisements.....8.46
- Declaration of Secrecy (see *Declaration of Secrecy*)
- nomination (see also *nomination of candidates*).....4.17-4.20
- notice of appointment of counting agents.....7.40
- notice of appointment of election agent.....7.8
- notice of appointment of polling agents.....7.23
- notice of authorisation of persons to incur election expenses.....7.16-7.17
- notice of posting of election communication.....8.81
- notice of revocation of appointment of agents.....7.10, 7.18, 7.24, 7.41
- notice of withdrawal of candidature.....4.36
- notification for public meeting or procession (see also *notification to the
Police*).....9.7
- notification of decision on electioneering activities in a building.....10.36
- permission to raise funds.....9.21, Appendix H
- return and declaration and cross-authorisation.....16.47, 16.49-16.50
- return and declaration of election expenses and donations.....16.23-16.25
- return of election deposit.....4.24
- standard receipt for donations.....16.19, 16.25

free postage of election advertisement (see *election advertisement*)

functional constituency (FC)

- application for registration as an elector.....3.17-3.20

functional constituency (FC) (*Cont'd*)

- authorised representative	
- eligibility for appointment	3.12-3.13
- notice of appointment	3.14
- composition and electors	3.3, Appendix B
- corporate elector	3.7-3.8, 3.12-3.14
- counting	5.63-5.72
- disqualification	
- for nomination as a candidate	4.5-4.6
- for registration as an elector	3.15
- eligibility to vote	3.4
- final register	3.27
- nomination	
- form/paper	4.18
- notice	4.37
- of candidate	4.16-4.20
- omission list	3.25-3.26
- ordinary functional constituency	3.28, 3.30-3.33
- polling arrangements	5.1-5.47, Appendix D
- polling station (see also <i>polling station</i>)	3.19, 5.1-5.47
- provisional register	3.24
- qualification	
- for nomination as a candidate	4.3
- for registration as an elector	3.5-3.11, Appendix B
- for registration as an authorised representative	3.12-3.14, Appendix B
- roll-over of electors	3.16
- special functional constituency (SFC) (see also <i>special functional constituency</i>)	3.11, 3.28-3.29
- subscriber	4.18
- voting system (see also <i>first past the post system</i>)	3.28, 3.30-3.33
fund raising activities	9.21, Appendix H

g

gazettal of result (see also <i>result</i>)	5.74-5.75
general election (see also <i>election</i>)	1.2, 1.18-1.19, 2.2, 3.2
geographical constituency (GC)	
- application for registration as an elector	2.4-2.5, 2.8-2.10

geographical constituency (GC) (*Cont'd*)

- authorisation of election expense agent 7.15-7.17
- counting 5.53-5.62
- disqualification
 - for nomination as an candidate 4.5
 - for registration as an elector 2.6
- eligibility to vote 2.3
- final register 2.19
- nomination
 - form/paper 4.18
 - list 4.18, 4.39
 - notice 4.37
 - of candidates 4.16, 4.18-4.20
- omissions list 2.17-2.18
- polling arrangements 5.1-5.47, Appendix D
- polling station (see also *polling station*) 2.10, 2.21, 5.1-5.47
- provisional register 2.16
- qualification
 - for nomination as a candidate 4.2
 - for registration as an elector 2.4-2.5
- subscriber 4.18, 4.32
- voting system (see also *list system of proportional representation*) 2.20-2.27

government officials (see also *Principal Officials*)

- attending public functions 19.1, 19.4-19.7, 19.9
- civil servants acting as agents for candidates 7.6
- supporting electioneering activities of a candidate 7.6, 19.2-19.3

h

handbook, ICAC (see also *ICAC, Handbook*) 17.2, Appendix M

hotline

- complaints 20.7, 20.9
- enquiry on designation of polling station 5.11
- enquiry on information of candidates by school principals 13.9

hours of poll (see also *polling hours* and *voting*) 5.12, 5.42

i

ICAC, Handbook (see also <i>corrupt and illegal conduct</i>)	17.2, Appendix M
identification of	
- canvassers conducting electioneering activities in a building	10.37
- electors at polling stations (see also <i>elector</i>)	5.21
- interviewers conducting exit poll	15.9-15.10
illegal conduct	
- court to excuse innocent acts	17.27-17.29
- election advertisement	8.11, 8.58, 8.66, 17.15
- election expenses exceeding maximum amount	16.9, 16.13, 16.54, 17.26
- false claim of support	17.10, 17.14, 18.1, 18.14
- false or misleading statement about a candidate	17.8-17.9, 17.14
- incurring election expenses without authority	8.64, 8.66, 16.10, 17.26
- namedropping	18.1-18.14
- penalty	16.54-16.59, 17.4, 17.34
- voting offences	17.25
impersonation	5.24, 7.25, 7.30
incapacitated elector (see also <i>disability of electors</i> and <i>elector</i>)	5.11, 5.25, 5.37, 7.34-7.36
incumbent candidates	8.3-8.5
information in	
- final register	2.19, 3.27
- introductory leaflet	4.59-4.61, 5.16
- omissions list	2.17-2.18, 3.25-3.26
- poll card	5.7, 5.10
- provisional register	2.16, 3.24
inspection	
- election advertisement (see also <i>election advertisement</i>)	8.54, 8.81
- final register (see also <i>final register</i>)	2.19, 3.27
- nomination form	4.20
- provisional register (see also <i>provisional register</i>)	2.16, 3.24
- return and declaration of election expenses and donations (see also <i>return and declaration of election expenses and donations</i>)	7.21, 16.51
introductory leaflet	
- contents	4.59-4.61
- enlarged copy	5.16
- submission of message and photograph to RO	4.60
- to whom it will be sent	4.59

invalid ballot paper (see also <i>ballot paper</i>).....	5.56-5.57, 5.66-5.67
invalid nomination (see also <i>nomination of candidates</i>).....	4.25-4.35

l

Legislative Council (LegCo)

- by-election (see also <i>election</i>).....	1.2, 1.18-1.19
- composition.....	1.3-1.5
- function.....	1.1
- general election (see also <i>election</i>).....	1.2
- governing legislation on elections.....	1.7-1.15
- term of office.....	1.2

list system of proportional representation

- application.....	1.4, 2.20, 3.28, 8.14
- invalid vote.....	5.56
- marking of ballot papers.....	5.28-5.29
- nomination of candidates.....	2.22
- quota of votes.....	2.22
- remainder votes.....	2.22-2.23
- single vote for a list.....	2.22-2.23
- voting and counting procedures.....	2.23-2.27

locking of ballot box (see *ballot box*)

loud-hailer (see *loudspeaker*)

loudspeaker

- broadcasting van.....	12.4, 12.6-12.7
- other restrictions.....	5.16-5.17, 10.31, 12.2-12.5, 12.8, 14.9, 14.11
- sanction by EAC.....	10.31, 12.4
- time restriction.....	10.31, 12.4

m

mailing of election advertisement (see *election advertisement*)

main counting station (see also <i>counting station</i>).....	5.2, 5.47, 5.54-5.55
--	----------------------

management bodies.....	10.1, 10.10, 10.17-10.26, 10.36
------------------------	---------------------------------

management company.....	10.6, 10.17-10.26
-------------------------	-------------------

marking of ballot paper (see also <i>ballot paper</i>) ..	5.25, 5.28-5.30, 5.32, 5.34, 5.37, 7.36
--	---

maximum amount of election expenses (see also <i>election expenses</i>).....	8.10, 16.7-16.9
---	-----------------

media

- print
 - advertisements.....8.56, 11.13-11.15
 - fair and equal treatment.....11.14-11.15, Appendix I
 - restrictions on regular columnists.....11.15
- TV and radio (see also *election broadcasting* and *election forums*)...11.2-11.12

misconduct

- in or in the vicinity of counting station.....5.51-5.52, 7.46
- in or in the vicinity of polling station.....5.38-5.39, 5.41, 7.31-7.32

mobile exhibitions.....9.19-9.20

mobile telephone.....5.38, 7.31

mounting and installation of election advertisement (see also *election advertisement*)...
.....8.37-8.42

musicians, during election period.....11.10

mutual aid committee.....8.2, 8.63, 9.15, 9.19, 10.7, 10.17-10.26, 18.6, Appendix O

n

namedropping

- form of consent.....18.12-18.13, Appendix N
- guidelines for mutual aid committees.....18.6, Appendix O
- illegal conduct (see also *false claim of support* and *illegal conduct*)
.....18.1-18.13
- penalty (see also *censure* and *reprimand*).....18.14

negative campaigning.....16.11

no canvassing zone (NCZ)

- canvassing activities allowed/forbidden (see also *canvassing activities*).....
..5.16-5.17, 7.37, 12.8, 14.2, 14.9-14.11, 14.13-14.14, 14.16, 15.5, Appendix K
- designation.....5.3, 5.16, 14.3-14.4
- notice of declaration.....5.16, 14.3-14.8
- penalty.....14.16
- purpose.....5.16, 14.2
- variation.....5.3, 14.6-14.8

no-display areas (see also *election advertisement*).....5.16, 8.24-8.25

no staying zone (NSZ)

- canvassing activities forbidden.....5.16-5.17, 14.12-14.14
- designation.....5.3, 5.16, 14.3-14.4
- notice of declaration.....5.16, 14.3-14.8

no staying zone (NSZ) (<i>Cont'd</i>)	
- penalty.....	14.16
- purpose.....	5.16, 14.2
- variation.....	5.3, 14.6-14.8
no unfair advantage principle.....	11.4-11.8, 11.16
noise nuisance.....	12.2-12.5
nomination of candidates	
- corrupt conduct.....	17.5-17.7
- disqualifications.....	4.5-4.6
- false declaration.....	4.21
- form.....	4.17-4.20
- invalid.....	4.25-4.35
- notice of validly nominated candidates.....	4.26
- period.....	4.16
- procedure.....	4.17-4.20
- qualifications.....	4.2-4.4
- subscriber.....	4.18, 4.32
- validity.....	4.25-4.35
- withdrawal.....	4.36
Nominations Advisory Committees (NACs)	
- application period.....	4.8, 4.14
- application procedure.....	4.8-4.9, 4.14
- composition.....	4.7
- decision.....	4.10-4.13, 4.15
- non-binding effect.....	4.13, 4.15
- power.....	4.10-4.11, 4.14
- scope of work.....	4.8, 4.14
notification to RO regarding electioneering activities in a building.....	10.36
notification to the Police	
- public meeting (see also <i>public meeting</i>).....	9.6-9.10
- public procession (see also <i>public procession</i>).....	9.11-9.14
notice of	
- by-election (see also <i>by-election</i>).....	1.2
- declaration of no canvassing zone (see also <i>no canvassing zone</i>).....	5.16, 14.3-14.8
- general election (see also <i>general election</i>).....	1.2
- result of election (see also <i>counting station and result</i>).....	5.74-5.75
- validly nominated candidates (see also <i>nomination of candidates</i>).....	4.26

o

omissions list.....	2.17-2.18, 3.25-3.26
opening of ballot box (see also <i>ballot box</i>).....	5.45, 5.53, 5.63, 7.45
ordinarily resided in Hong Kong.....	2.4-2.5, 2.7, 2.13-2.14, 3.22-3.23, 4.2, 4.4, 4.18
ordinary functional constituency (see also <i>functional constituency</i>).....	1.6, 3.30, 4.24, 5.1, 5.5, 5.20, 5.28
- polling station.....	7.4, 7.36
- voting system (see also <i>first past the post system</i>).....	1.6, 3.28
owners committee.....	8.2, 8.63, 10.5-10.6, 10.17-10.26
owners corporation.....	8.2, 8.63, 9.15, 9.19, 10.3-10.6, 10.12-10.14, 10.17-10.26

p

paging machine.....	5.38, 7.31
particulars relating to candidates on ballot papers	
- application for registration of name and emblem.....	4.43-4.46
- processing of application.....	4.48-4.55
- registration and de-registration of name and emblem.....	4.56-4.58
- request to print particulars relating to candidates on ballot papers.....	4.39-4.42
- time of application.....	4.47
payment of election deposit (see also <i>election deposit</i>).....	4.19, 4.22-4.23
performance report (see also <i>election advertisement</i>).....	8.3-8.5
period for nomination (see also <i>nomination of candidates</i>).....	4.16
permission/authorisation of display	
- display of election advertisement at private premises.....	8.12-8.13, 8.18, 8.29, 8.48-8.50
- display of election advertisement on designated spots.....	8.12-8.14, 8.23
photograph, introductory leaflet.....	4.60
photographing inside	
- counting station (see also <i>counting station</i>).....	5.51
- polling station (see also <i>polling station</i>).....	5.41
poll card (see also <i>combined polling arrangement</i>)	
- contents.....	5.10
- date of sending.....	5.10
polling agent	
- appointment.....	7.22-7.23
- conduct inside polling station.....	5.20-5.41, 7.30-7.32
- lodging of complaint inside polling station.....	7.38, 20.9-20.10

polling agent (<i>Cont'd</i>)	
- number	7.4
- qualification/civil servants acting as agents	7.5-7.6
- revocation	7.24
- role	7.25, 7.30
polling day (see also <i>date</i>)	1.2
polling hours	5.12, 5.42
polling station	
- admission	5.18-5.19, 7.14, 7.26-7.28
- allocation	5.4, 5.10-5.11, 7.34
- canvassing activities forbidden	5.38, 5.41
- communication with electors inside	5.40
- conduct inside	5.20-5.41, 7.30-7.32
- conduct outside	5.16-5.17, 12.8, 14.9-14.15
- conversion of polling station to counting station (see also <i>counting station</i>)	5.1, 5.43, 5.48, 7.29
- designation	5.1-5.2, 5.4, 5.11
- display of notice of conversion from polling station to counting station	5.44
- functional constituency (see also <i>functional constituency</i>)	5.1-5.47
- geographical constituency (see also <i>geographical constituency</i>)	5.1-5.47
- persons with a disability	5.11, 7.34
- photographing, filming and recording	5.41
- re-allocation	5.11, 7.34-7.36
- small polling station	5.2, 5.43, 5.46-5.48, 5.55
- special functional constituency (see also <i>special functional constituency</i>)	1.6, 3.11, 3.28-3.29, 4.24, 5.1, 5.5, 5.7-5.8, 5.14, 5.20-5.21, 5.28-5.29, 5.31, 5.43
- special polling station	5.11
posting arrangement of election advertisement (see <i>election advertisement</i>)	
preferential elimination system	
- absolute majority of votes	3.29
- application	1.6, 3.28
- counting procedures	5.63-5.72, Appendix C
- definition	3.29
- marking of ballot papers	3.29, 5.28-5.29, 7.36
- preference vote	3.29, 5.28-5.29, 7.36
- single vote	3.29
- validity of vote	3.29, 5.66-5.70, 7.36

prescribed body	4.38-4.44, 4.47-4.57, 5.16-5.17, 5.38, 7.31, 11.6-11.7, 14.9, Appendix K
prescribed person	4.38-4.42, 4.45-4.56, 4.58, 16.2
presenters of TV, radio and movie, restrictions to appear in a programme	11.9-11.10
Presiding Officer (PRO)	
- after the close of poll	5.42-5.47
- assistance to elector	5.37, 7.35
- authorising a person to enter counting station	5.49
- before commencement of poll	5.12-5.13
- conduct of vote counting	5.53-5.62
- decision on a ballot paper	5.60
- decision on re-count of votes	5.62
- keeping order at polling and counting stations	5.39, 5.52
- making known and reporting the election result	5.62
- opening of ballot box at counting station	5.45, 5.53, 7.45
- overseeing main counting station (see also <i>counting station</i>)	5.44-5.45
- overseeing no canvassing zone	14.10, 15.5
- overseeing small polling station (see also <i>polling station</i>)	5.46-5.47
- questioning elector before issuing ballot paper	5.23, 7.30
- recording complaint	20.9-20.10
- regulating number of persons inside polling station	Note under 5.18, 7.14, Note under 7.26
- reporting irregularities to EAC	20.11, 20.17
Principal Officials (see also <i>government officials</i>)	19.9-19.12
print media (see also <i>media</i>)	
- advertising through	8.56, 11.13-11.15
- fair and equal treatment (see also <i>fair and equal treatment principle</i>)	11.14-11.15, Appendix I
printed election materials (see also <i>election advertisement</i>)	8.55-8.56, 17.15-17.17
printing details of election advertisement (see also <i>election advertisement</i>)	8.49, 8.55, 8.57-8.58
privacy of electors	10.30
private premises	
- display of election advertisement (see <i>election advertisement</i> and <i>fair and equal treatment principle</i>)	
- election meeting (see also <i>election meeting</i>)	9.5, 9.8, 9.15-9.18

private premises (<i>Cont'd</i>)	
- electioneering activities (see <i>electioneering activities</i> and <i>fair and equal treatment principle</i>)	
private spots for displaying election advertisement (see also <i>election advertisement</i>)....	
.....	8.13, 8.18, 8.46, 10.21-10.22
procedure	
- complaints (see also <i>complaints</i>).....	20.7-20.10
- nomination (see also <i>nomination of candidates</i>).....	4.17-4.20
propaganda material.....	5.16-5.17,
	5.38, 7.31, 7.37, 8.2, 8.44, 14.9
provisional register	
- abuse or misuse of information.....	Important under 2.19, Important under 3.27
- appeals.....	2.18, 3.26
- contents.....	2.16, 3.24
- date of publication.....	2.16, 3.24
- electors to change particulars.....	2.12-2.15, 3.21-3.23
- inclusion of an elector's name.....	2.9-2.16, 3.18-3.24
- inspection.....	2.16, 3.24
public function.....	19.1, 19.4, 19.8
public fund-raising permits (see also <i>fund raising activities</i>).....	9.21, Appendix H
public housing estates (see also <i>electioneering activities</i>).....	8.26, 9.17, 9.19, 10.34
public meeting (see also <i>election meeting</i>)	
- notification.....	9.6-9.9
- prohibition.....	9.9-9.10
- responsibility of organiser.....	9.10
public observation inside counting station (see also <i>counting station</i>).....	5.49-5.50
public procession.....	9.4, 9.11-9.14
- notification to the Police.....	9.12
public statement.....	1.21, 8.62, 8.86, 10.38, 11.19, 12.9, 13.10, 15.11, 17.33
pupil involvement	
- canvassing activities (see also <i>canvassing activities</i>).....	13.2-13.8
- sanction (see also <i>censure</i> and <i>reprimand</i>).....	13.2, 13.10
- undue influence (see also <i>force or duress</i>).....	13.2, 13.4
q	
qualification	
- authorised representative (see also <i>authorised representative</i>).....	3.12

qualification (*Cont'd*)

- candidate (see also <i>candidate</i>).....	4.2-4.4
- counting agent (see also <i>counting agent</i>).....	7.5-7.6
- election agent (see also <i>election agent</i>).....	7.5-7.6
- election expense agent (see also <i>election expense agent</i>).....	7.5-7.6
- elector (see also <i>elector</i>)	
- in a FC election.....	3.5-3.11
- in a GC election.....	2.4-2.5
- polling agent (see also <i>polling agent</i>).....	7.5-7.6
- subscriber (see also <i>subscriber</i>).....	4.18, 4.32
questionable ballot paper (see also <i>ballot paper</i>).....	5.54-5.60, 5.62, 5.66-5.67

r

re-allocation of polling station (see also <i>polling station</i>).....	5.11, 7.34-7.36
--	-----------------

recording inside

- counting station (see also <i>counting station</i>).....	5.51
- polling station (see also <i>polling station</i>).....	5.41

re-count of votes (see also <i>counting of votes</i>).....	5.62, 5.72
---	------------

register

- final register (see <i>final register</i>)	
- provisional register (see <i>provisional register</i>)	
- use of information contained.....	Important Note under 2.19, Important Note under 3.27

Registration and Electoral Office (REO) (see also *Chief Electoral Officer* and *Electoral Registration Officer*)

- processing application for registration of electors.....	2.9-2.10, 2.19, 3.18-3.19, 3.27
- public inspection of registers.....	2.16, 2.19, 3.24, 3.27
- reporting irregularities to EAC.....	20.11, 20.17

regular columnists, restrictions to contribute articles.....	11.15
--	-------

regular contributors, restrictions to appear in a programme.....	11.9-11.10
--	------------

reprimand (see also *censure*)

- breach of time restriction when using loud-hailers.....	10.31, 12.4
- breach/non-compliance of Guidelines.....	1.21, 8.62, 10.38-10.39, 11.19, 12.9, 13.10, 15.11, 16.52, 17.30, 17.33, 20.1, 20.4, 20.14
- corrupt and illegal conduct.....	17.33
- exit poll.....	15.11

reprimand (see also *censure*) (*Cont'd*)

- false claim of support..... 17.33, 18.14
- involving youths of school age..... 13.2, 13.10
- namedropping..... 17.33, 18.14
- opportunity to make representations..... 20.14
- unauthorised display of election advertisements..... 8.62
- unauthorised electioneering against the decision of an organisation or building..... 10.27-10.28
- unfair and unequal treatment..... 10.19, 10.38-10.39, 11.19

residents association..... 10.7, 10.17-10.26

restricted zone..... 5.49

restrictions on

- canvassing activities in no canvassing zone and no staying zone..... 5.16-5.17, 14.9-14.15, 15.5, Appendix K
- presenters..... 11.9-11.10
- regular columnists..... 11.15
- regular contributors..... 11.9-11.10
- use of loudspeaker (see also *loudspeaker*)..... 5.16-5.17, 10.31, 12.2-12.5, 12.8, 14.9, 14.11

result

- declaration..... 2.26-2.27, 3.32-3.33, 5.73-5.75
- gazettal..... 5.74-5.75
- notice..... 5.74-5.75

return and declaration and cross-authorisation..... 16.46-16.49

- alteration..... 16.48

return and declaration of election expenses and donations

- court power to excuse innocent acts..... 17.29
- delivery..... 16.23
- false information..... 16.57
- omissions and mistakes..... 16.26
- penalty for non-compliance..... 16.56, 16.58-16.59
- public inspection..... 7.21, 16.51
- requirement..... 16.24

return of election deposit (see also *election deposit*)..... 4.24

Returning Officer (RO)

- allocation of designated spots..... 8.14-8.17, 8.22-8.23, 8.26-8.30
- authorising a person to enter polling station for liaison purposes..... 5.18
- authorising a person to enter counting station..... 5.49

Returning Officer (RO) (*Cont'd*)

- decision on a ballot paper.....5.62, 5.69-5.70
- declaration of election result.....2.26-2.27, 3.32-3.33, 5.73-5.75
- designation and declaration of no canvassing zone and no staying zone.....5.3,
5.16, 14.3-14.8
- designation of designated spots.....8.14-8.16
- displaying notice of result.....5.74-5.75
- giving notice of place for vote counting.....5.2
- handling complaints.....8.62, 20.4, 20.9-20.14
- keeping order at polling and counting stations.....5.39, 5.52
- opening of ballot box at counting station.....7.45
- providing sketch maps of polling stations and no canvassing zones.....8.24
- reporting irregularities to EAC.....20.11, 20.17

Revising Officer.....2.18-2.19, 3.26-3.27

revocation

- counting agent (see also *counting agent*).....7.41
- election agent (see also *election agent*).....7.10-7.11
- election expense agent (see also *election expense agent*).....7.18
- polling agent (see also *polling agent*).....7.24

role

- counting agent (see also *counting agent*).....7.42
- election agent (see also *election agent*).....7.13-7.14
- election expense agent (see also *election expense agent*).....7.19, 16.10
- polling agent (see also *polling agent*).....7.25, 7.30

s

schools, electioneering activities.....13.8-13.9

school pupils (see *pupil involvement*)

sealing of ballot box (see *ballot box*)

secrecy of the vote.....5.6, 5.19, 5.33, 5.50, 7.27, 7.44, 15.8

- exit poll (see also *exit poll*).....15.8
- inside counting station.....5.50, 7.44
- inside polling station.....5.19, 5.33, 7.27

secrecy of voting (see *secrecy of the vote*)

serial numbering of election advertisement (see also *election advertisement*).....
.....8.44-8.46

singers, during election period.....11.10

small polling station (see also <i>polling station</i>)	5.2, 5.43, 5.46-5.48, 5.55
special functional constituency (SFC)	
- application for registration as an elector	3.17-3.20
- authorised representative	
- eligibility for appointment	3.12-3.13
- notice of appointment	3.14
- composition and electors	3.3, Appendix B
- corporate elector	3.7-3.8, 3.12-3.14
- counting	5.63-5.72
- disqualification	
- for nomination as a candidate	4.5-4.6
- for registration as an elector	3.15
- eligibility to vote	3.4
- final register	3.27
- nomination	
- form/paper	4.18
- notice	4.37
- of candidate	4.16-4.20
- omission list	3.25-3.26
- polling arrangements	5.1-5.47, Appendix D
- polling station (see also <i>polling station</i>)	3.19, 5.1-5.47
- provisional register	3.24
- qualification	
- for nomination as a candidate	4.3
- for registration as an elector	3.5-3.11, Appendix B
- for registration as an authorised representative	3.12-3.14, Appendix B
- roll-over of electors	3.16
- subscriber	4.18
- voting system (see also <i>preferential elimination system</i>)	3.28-3.29, 3.32-3.33
	Appendix C
special polling station (see also <i>polling station</i>)	5.11
spoilt ballot paper (see also <i>ballot paper</i>)	5.34, 5.42, 5.56, 5.66, 7.29
subscriber (see also <i>nomination of candidates</i>)	
- number required	4.18, 4.32
- qualification	4.18, 4.32

t

template (see also <i>visually impaired elector</i>)	5.32, 7.36
tenants association	8.2, 8.63, 10.7, 10.17-10.26
tendered ballot paper (see also <i>ballot paper</i>)	5.35, 5.56, 5.66, 7.29
treating (see also <i>corrupt conduct</i>)	9.3, 17.19-17.22
TV and radio (see also <i>election broadcasting</i> and <i>election forums</i>)	11.2-11.12
types and numbers of agents	7.4

u

undue influence (see also <i>force or duress</i>)	13.2, 13.4, 17.23-17.24
unissued ballot paper (see also <i>ballot paper</i>)	5.13, 5.42-5.45, 5.47, 7.29
unused ballot paper (see also <i>ballot paper</i>)	5.25-5.26, 5.36, 5.42, 5.56, 5.66, 7.29

v

validity

- ballot paper (see also *ballot paper*) 5.54-5.58, 5.66-5.69
- nomination (see also *nomination of candidates*) 4.25-4.35

visual deficiency (see also <i>elector</i>)	5.37, 7.35-7.36
--	-----------------

visually impaired elector (see also *elector*)

- assistance to mark a ballot paper 5.37, 7.35-7.36
- template 5.32, 7.36

voluntary service	16.3, 16.18, 16.22
-------------------	--------------------

voting

- corrupt conduct (see also *corrupt conduct*) 17.25
- date (see also *date* and *polling day*) 1.2
- disqualification 2.6, 3.15
- eligibility 2.3, 3.4
- empty opaque bag 2.25, 3.31, Annex to Appendix C
- marking of ballot paper (see also *ballot paper*) 5.28-5.30, 5.32, 5.34, 5.37, 7.36
- number of vote allowed 2.23, 3.29-3.30
- secrecy (see *secrecy of the vote*)
- time (see also *hours of poll* and *polling hours*) 5.12, 5.42
- where 5.1-5.2, 5.4-5.11, 7.34

voting compartment	5.28, 5.31, 5.36, 7.31
--------------------	------------------------

voting offences (see also <i>corrupt conduct</i>)	17.25
--	-------

voting preference (see also *corrupt conduct*).....17.18-17.19

voting system

- first past the post (see also *first past the post system*).....1.6, 3.28, 3.30-3.33,
5.29, 5.66, 7.36
- list system of proportional representation (see also *list system of proportional
representation*).....1.4, 2.20, 2.22-2.27, 3.28, 5.28-5.29
- preferential elimination system (see also *preferential elimination system*)...1.6,
3.28-3.29, 5.63-5.72, 7.36

w

websites of candidates.....8.2, 8.48-8.49

withdrawal of candidature (see also *candidate, corrupt conduct and false statement*)....

.....4.18, 4.24, 4.36

香港灣仔港灣道 25 號
海港中心 10 樓

10/F, Harbour Centre
25 Harbour Road
Wan Chai
Hong Kong

本函檔號 OUR REF.: REO 14/10/2/LC-04

圖文傳真 Fax: 2511 1682

來函檔號 YOUR REF.:

電話 Tel.: 2827 1269

網址 Web Site: <http://www.info.gov.hk/eac/>

22 March 2004

(With Chinese translation)

Message from the Chairman

Public Consultation on the Proposed Guidelines on Election-related Activities in respect of the Legislative Council Elections

The 2004 Legislative Council (“LegCo”) Election will be held in September 2004. The Electoral Affairs Commission (“EAC”) is empowered under section 6(1)(a) of the EAC Ordinance (Chapter 541 of the Laws of Hong Kong) to issue guidelines to facilitate the conduct or supervision of an election. The aim of these guidelines is to provide a code of conduct based on the principle of fairness and equality for conducting election-related activities and some directions in layman’s language on how to comply with the relevant electoral legislation so that candidates can avoid breaching them due to inadvertence.

The EAC has at all times made its best endeavours in refining and improving the electoral arrangements for public elections. Before each general election, the EAC will revise the electoral guidelines. The revision is done on the basis of the guidelines used for previous elections, taking into account the operational experience of each election, as well as suggestions and complaints received from the public and other parties concerned. A new set of proposed guidelines has now been drawn up in this manner by the EAC for the conduct of LegCo Election to be held in September 2004 and for all LegCo general elections and by-elections to be held afterwards. The proposed guidelines are modelled basically on those used for the 2000 LegCo Election and the 2003 DC Election, with suitable amendments to reflect the operational experience and suggestions for improvements obtained from the previous elections. The major changes proposed as compared against the guidelines for the 2000 LegCo Election are set out in the **Appendix**.

Before finalising the guidelines for issue to the public, we shall, in accordance with section 6(2) of the EAC Ordinance, consult the public on the proposed guidelines for a period of 30 days starting from **22 March to 20 April 2004**, both dates inclusive. At this stage the EAC has taken no decision with respect to the issues addressed in the proposed guidelines. The final decision will be taken in the light of responses received to this consultation exercise.

Please send your written representations on the proposed guidelines to the EAC Secretariat at 10/F, Harbour Centre, 25 Harbour Road, Wan Chai, Hong Kong, or by fax (fax no.: 2511 1682) or e-mail (eacenv@reo.gov.hk) the latest by **20 April 2004**. **Late representations will not be considered.** Please indicate clearly in your response if you wish your response or your name to remain confidential. You may also make representations to us orally at a public forum to be held on **2 April 2004 at 2:30 pm** at the **EAC Conference Room, 10/F Harbour Centre, 25 Harbour Road, Wan Chai, Hong Kong**. For enquiries, please call 2827 1269.

The EAC is committed to making every endeavour to ensure that all public elections are held in an open, fair and honest manner. No doubt those who have opposing views and suggestions will make representations to us. **However, it is important that supporting views should also be made known to us, for otherwise it may be said that no one supports or agrees with our proposed guidelines.**

Yours faithfully,

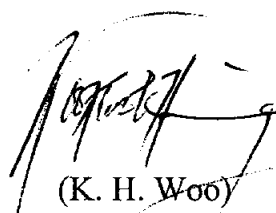

(K. H. Woo)
Chairman

Electoral Affairs Commission

(With enclosure)

**Major Changes Proposed in the LegCo Electoral Guidelines
as Compared Against the Guidelines for the 2000 LegCo Election**

Relevant Chapter	Major Changes
<p>Chapter 2</p> <p><i>Geographical constituencies (“GCs”)</i></p>	<p>Changes to reflect the new dates regarding voter registration for GCs in a non-District Council (“DC”) election year in light of the new provisions in the Electoral Affairs Commission (Registration of Electors) (Legislative Council Geographical Constituencies) (District Council Constituencies) Regulation -</p> <ul style="list-style-type: none"> ● <i>closing date for application for registration:</i> 16 May instead of 16 March; ● <i>publication of the provisional register:</i> on a date not later than 15 June instead of 15 April; ● <i>publication of the final register:</i> on a date not later than 25 July instead of 25 May; and ● <i>the deadline for receiving requests for change of particulars and for lodging claims and objections:</i> 29 June instead of 29 April. <p>The section on the voting system has also been revised to include more details on drawing of lots in the event of an equality of votes.</p>
<p>Chapter 3</p> <p><i>Functional constituencies (“FCs”)</i></p>	<p>The new dates on FCs voter registration in a non-DC election year, which are the same as those of the GCs, have been reflected in light of the new provisions in the Electoral Affairs Commission (Registration) (Electors for Legislative Council Functional Constituencies) (Voters for Election Committee Subsectors) (Members of Election Committee) Regulation. The arrangement on drawing of lots has also been included in the section on voting system.</p>
<p>Chapter 4</p> <p><i>Nomination of candidates</i></p>	<ul style="list-style-type: none"> ● revised subscription requirements to allow a candidate list in the GC election to submit no more than 200 subscribers and a candidate in FC election no more than 20 subscribers in accordance with s 7(1) and (2) of the Legislative Council (Subscribers and Election Deposit for Nomination) Regulation (para. 4.18); ● requiring electors subscribing a nomination to sign the nomination form personally (para. 4.18(a));

Relevant Chapter	Major Changes
	<ul style="list-style-type: none"> ● requiring candidates to make a declaration in the nomination form that they have ordinarily resided in Hong Kong for the preceding 3 years (para. 4.18(b)(v)); and ● adding a section setting out the new requirements for printing of specified particulars relating to candidates on ballot papers according to the Particulars Relating to Candidates on Ballot Papers (Legislative Council) Regulation (Part VIII).
<p>Chapter 5</p> <p><i>Polling and counting arrangements</i></p>	<p><i>Proposed Polling Arrangements for FCs/Special FCs (“SFCs”) (paras. 5.1 and 5.5)</i></p> <ul style="list-style-type: none"> ● As in previous LegCo elections, all the polling stations set up for the GCs will also serve FC electors. In the 2000 LegCo Election, 4 out of these GC polling stations were also designated to serve the Election Committee (“EC”) and 4 SFCs (ie Heung Yee Kuk, Agriculture and Fisheries, Insurance and Transport); and ● For the 2004 LegCo Election, as the EC will no longer elect LegCo members, this special polling arrangement is no longer necessary. It is proposed that the polling stations set up for the GCs will also serve all FC and SFC electors. <p><i>Proposed Vote Counting Arrangements for GCs (paras. 5.53 to 5.62)</i></p> <ul style="list-style-type: none"> ● Having reviewed the experience of the 2003 DC Election and in view of the operational problems associated with the transportation of ballot boxes arising from the introduction of the much larger ballot papers, the EAC proposes that vote counting for GCs in the coming LegCo election should be decentralized to individual polling stations. <p><i>Proposed Vote Counting Arrangements for FCs/SFCs (paras. 5.63 to 5.72)</i></p> <ul style="list-style-type: none"> ● The EAC considers that it will not be efficient for individual polling stations to handle the counting of votes for 28 FCs. It is therefore proposed that vote counting for FCs/SFCs be conducted at the central counting station as in previous LegCo elections.

Relevant Chapter	Major Changes
<p>Chapter 7</p> <p><i>Appointment and roles of election agent, election expense agents, polling agents and counting agents</i></p>	<ul style="list-style-type: none"> ● In line with the notification period for appointment of polling agents, notification of appointment of counting agents to be given to the Returning Officer (“RO”) at least 1 week, instead of 3 working days, before polling day (paras. 7.23 and 7.40); and ● adding that a polling agent must not display in a polling station any propaganda material which makes direct reference to a prescribed body which has given consent to its registered name or emblem to be printed on any ballot paper (para. 7.31 and also paras. 5.16, 5.17 and 5.38 of Chapter 5, para. 14.9 of Chapter 14 and Appendix K).
<p>Chapter 8</p> <p><i>Election advertisements</i></p>	<ul style="list-style-type: none"> ● more details on how election expenses should be counted for prejudicing the election of a candidate (paras. 8.7 to 8.8); ● more details on how the value of a commercial/ non-commercial space for display of election advertisements should be accounted for (para. 8.18); ● issuing a notice to candidates by the ROs requiring them to remove their election advertisements posted at the private premises within the No Canvassing Zone (“NCZ”) on the polling day (para. 8.24 and also para. 14.9 of Chapter 14); ● clarifying that the reference to the total area of all the spaces for joint election advertisements not exceeding the total area of the designated spots allocated to each candidate should refer to the spaces actually occupied by election advertisements, not the number of designated spots (para. 8.32); ● adding that all candidates should make known to the electors the name of their respective constituencies in the conduct of joint canvassing activities (para. 8.34); ● clarifying that if the contents of a candidate’s website are changed, the candidate must make a new declaration and to deposit 2 hard copies of the modified pages with the RO (para. 8.48); ● the RO may exercise his discretion to accept a joint declaration and a joint submission of 2 copies of election advertisements in case of candidates using identical copies of election advertisements (para. 8.50);

Relevant Chapter	Major Changes
	<ul style="list-style-type: none"> ● clarifying that the publication by an organisation would not be treated as an election advertisement if the activity advertised is part of the organisation's normal functions, is not election-related and does not promote any candidature (para. 8.63); ● posting free of postage 1 letter (instead of 2) to each elector (para. 8.67); and ● clarifying on how election advertisements in folder forms should be sealed under the free postage arrangement (para. 8.74 and Appendix E).
<p>Chapter 9</p> <p><i>Election meetings</i></p>	<p>Updating the particulars to be included in the notice to the Police on holding of election meetings or public processions and the requirements for such notice (paras. 9.7, 9.8, 9.11 and 9.12).</p>
<p>Chapter 10</p> <p><i>Electioneering at the living or working places of electors, premises of organisations to which electors belong and buildings which electors frequent</i></p>	<ul style="list-style-type: none"> ● defining the scope of electioneering activity in more details (para. 10.1); ● requesting all management bodies of the organisations or buildings concerned to apply fair and equal treatment to all candidates/GC lists of each constituency, instead of dealing with each application from them separately (para. 10.19); and ● requiring all persons who put up any publicity materials, including those which do not look election-related, in the nomination period on private premises should declare to the management body concerned whether they are candidates or intend to stand as candidates in the election (para. 10.26).
<p>Chapter 11</p> <p><i>Election broadcasting, media reporting and election forums</i></p>	<ul style="list-style-type: none"> ● allowing candidate to take part freely in non election-related programmes in which the 'equal time' principle will not apply (para. 11.3); ● clarifying that when inviting a candidate to attend an election-related programme, all the other candidates of the same constituency should also be invited (para. 11.5); ● clarifying that if a political party whose members contest as candidates is invited to attend an election-related programme, all political parties concerned, whether or not contesting in the same constituency or prescribed bodies which have their names or emblems being used on any ballot papers, should also be invited (para. 11.7);

Relevant Chapter	Major Changes
	<ul style="list-style-type: none"> ● broadcasters to be requested to treat all candidates fairly and equally when making comments on or drawing reference to the candidates in any of their programmes (para. 11.8); ● restricting a candidate's appearance (i) on TV/radio/movie as presenters, regular contributors, actors, musicians, singers or other entertainers and (ii) in commercial advertisements after the declaration of intention to run for the election (paras. 11.9 to 11.12); and ● advising broadcasters to invite all candidates of the same constituency to attend election forums and appealing to any organisations such as schools to invite all candidates of the same constituency to attend any such forums (paras. 11.16 to 11.18).
<p>Chapter 12</p> <p><i>Use of sound amplifying device and broadcasting vans</i></p>	<ul style="list-style-type: none"> ● adding a definition on amplification device (para. 12.3); ● making a nuisance by using megaphone, or other device or instrument for magnifying sound is also an offence under the Noise Control Ordinance (para. 12.4); ● an additional statement to remind candidates to consider the public's concern over the noise level of loudspeakers on broadcasting vans (para. 12.4); and ● reminding the candidates to observe the traffic regulations including seating requirements, wearing of seat belts etc and not to stand up in moving vehicles (para. 12.6).
<p>Chapter 14</p> <p><i>Prohibition against canvassing activities outside polling stations</i></p>	<ul style="list-style-type: none"> ● allowing door-to-door canvassing provided that permission has also been obtained for entry to the building for canvassing votes (para. 14.9); and ● not allowing any activity (eg lion dance) in the vicinity of the NCZ so that the noise emitted can be heard within the NCZ (para. 14.11).
<p>Chapter 16</p> <p><i>Election expenses and donations</i></p>	<ul style="list-style-type: none"> ● a prescribed person who has applied to have his emblem registered should not be treated as having publicly declared as a candidate (para. 16.2); ● candidates not allowed to use public resources to promote his election (para. 16.6);

Relevant Chapter	Major Changes
	<ul style="list-style-type: none"> ● the deadline for submitting the election return changed to not later than 60 days after gazettal of election result (para. 16.23); and ● a new section setting out the Financial Assistance Scheme for candidates under the Electoral Affairs Commission (Financial Assistance for Legislative Council Elections) (Application and Payment Procedure) Regulation (Part VI).
<p>Chapter 18 <i>Namedropping</i></p>	<ul style="list-style-type: none"> ● more clarifications as to why written consent of support is needed and as to what amounts to 'support' (para. 18.1); ● more clarifications on the use of title of office bearer (para. 18.4); ● more clarifications on whether a candidate needs to share the expenses for the election advertisements if he appears in another candidate's election advertisement to indicate his support (para. 18.9); ● a new provision introducing the addition of a caption to a photograph in an election advertisement as a means to minimize misunderstanding regarding consent of support (para. 18.10); and ● advising the candidates not to distribute their election advertisements together with any materials published by any person, organisation, or government agency or department (para. 18.11).
<p>Chapter 19 <i>Attendance of public functions by both government officials and candidates</i></p>	<p>A new chapter briefly describing the subject of government officials attending public functions which are also attended by candidates.</p>