

FINAL DRAFT DESIGN MANUAL

BARRIER FREE ACCESS

(Revision 11)

CONTENTS

	Page
PREFACE	1
CHAPTER 1 FOREWORD	2
CHAPTER 2 EXTENT OF APPLICATION AND DEFINITIONS	
2.1 EXTENT OF APPLICATION	4
2.2 EXEMPTIONS	8
2.3 DEFINITIONS	9
CHAPTER 3 ACCESSIBLE PROVISIONS FOR SPECIAL AREAS	
3.1 AUDITORIUM AND BACKSTAGE FACILITIES	11
3.2 HOTELS, HOSTELS AND GUESTHOUSES	15
3.3 CARPARKS	17
CHAPTER 4 GENERAL DESIGN REQUIREMENTS	
4.1 ACCESS	22
4.2 RAMPS	27
4.3 DROPPED KERBS	31
4.4 STEPS AND STAIRCASES	36
4.5 HANDRAILS	41
4.6 CORRIDORS, LOBBIES AND PATHS	47
4.7 DOORS	55
4.8 TOILETS & W.C. CUBICLES	60
4.9 BATHROOMS AND SHOWER COMPARTMENTS	69
4.10 SIGNS	73
4.11 INFORMATION / SERVICE COUNTERS	84
CHAPTER 5 BUILDING SERVICES DESIGN REQUIREMENTS	
5.1 SWITCHES AND CONTROLS	87
5.2 ILLUMINATION	89
5.3 FIRE ALARM SYSTEMS	91
5.4 EMERGENCY ALARM IN ACCESSIBLE TOILETS	94
5.5 PUBLIC TELEPHONES	95
5.6 ASSISTIVE LISTENING SYSTEMS	98
5.7 LIFTS	100
5.8 INDICATION AND NOTIFICATION FOR LIFTS COMPLYING WITH SECTION 5.7	108
5.9 ESCALATORS / PASSENGER CONVEYORS	110
5.10 VERTICAL LIFTING PLATFORMS	112
5.11 REMOTE SIGNAGE SYSTEMS	115
5.12 DRINKING FOUNTAINS	116

CONTENTS

	Page
CHAPTER 6 DESIGN GUIDELINES FOR THE ELDERLY AND ELDERLY WITH FRAILITY	
6.1 GENERAL	119
6.2 DESIGN CONSIDERATIONS	119

APPENDICES

Appendix A – Anthropometrics	A/1-A/5
Appendix B – Guidelines for Wheelchair Transfer and Movement	B/1-B/5
Appendix C – Slip Resistance of Flooring Materials	C/1
Appendix D – Luminous Contrast	D/1–D/3

LIST OF FIGURES

Figure 1A - Wheelchair Space in an Auditorium	12
Figure 1B - Example of Wheelchair Spaces in a Lecture Theatre	14
Figure 2 - Typical Guest Room Layout	16
Figure 3 - Dimension and Identification of Car Parking Space for Persons with a Disability	18
Figure 4 - Side by Side Parking Spaces for Persons with a Disability	19
Figure 5 - Parking Space Indication Signage	21
Figure 6A - Tactile Guide Paths at Building Entrances Linking up with Initial Access on the Lot Boundary and Interior Facilities	23
Figure 6B - Typical Tactile Guide Path Junction	24
Figure 6C - Examples of Details of Tactile Warning Tiles / Blocks	25
Figure 7 - Tactile Warning Strip and Landings for Ramps	28
Figure 8 - Running Slope and Length	29
Figure 9 - Dropped Kerb	32
Figure 10 - Examples of Design of Dropped Kerb	34
Figure 11 - Dropped Kerb at Street Corner	35
Figure 12 - Dropped Kerb for Access Road and Narrow Pavement	35
Figure 13 - Arrangement of Tactile Warning Strips and Handrails at Staircases	38
Figure 14 - Example of Staircase Plan for Persons with a Disability	40
Figure 15 - Handrails	42
Figure 16A - Handrails of Staircase	44

CONTENTS

LIST OF FIGURES

	Page
Figure 16B - Handrail in Recess	46
Figure 17 - Grating Size and Orientation	48
Figure 18 - Width of Controlled Passages	49
Figure 19 - Overhead Hazard	50
Figure 20 - Dimension and Space Allowances for Corridors in Buildings	52
Figure 21 - Examples of Design to Cater for Protrusion Hazards	54
Figure 22 - Plan of Doors Suitable for Wheelchair	56
Figure 23 - Guardrails at Out-swinging Automatic Doors	59
Figure 24 - Accessible Toilet	64
Figure 25 - Accessible Urinal	65
Figure 26 - Flap-type Diaper Changing Station	67
Figure 27 - Example of Bathroom and Shower Compartment	72
Figure 28 - Proportional Layout for International Symbol of Accessibility	73
Figure 29 - Directional Signs	74
Figure 30 - Proportional Layout for International Symbol of Access for Hearing Loss	75
Figure 31 - Specification of Braille Cells	76
Figure 32 - Braille and Tactile Fire Exit Map	77
Figure 33 - Tactile Guide Path to Lift Zone	78
Figure 34 - Tactile Guide Path to Information / Service Counter	79
Figure 35 - Tactile Guide Path to Tactile / Braille Directory Map / Floor Plan	79
Figure 36 - Tactile Warning Strip to Escalator / Passenger Conveyor	80
Figure 37 - Examples of Public Information Symbols	82
Figure 38 - Front View of Information / Service Counter for Wheelchair Users	85
Figure 39 - Key Heights of Counters and Reception Desks	86
Figure 40 - Heights of Switches and Controls	88
Figure 41 - Digit 5 Indicator	95
Figure 42 - Accessible Lift	101
Figure 43 - Tactile Graphic for Lift Control Buttons	103
Figure 44 - Proposed Standardised Position of Buttons for Keypad Control Device	106
Figure 45 - Vertical Lifting Platform	114
Figure 46 - Built-in Drinking Fountain	118
Figure 47 - Examples of Door Handles and Faucets	124

PREFACE

1. This Design Manual is an updated version of the “Design Manual: Barrier Free Access 1997”.
2. The Design Manual : Barrier Free Access 1997 sets out the design requirements of providing proper access to and appropriate facilities in a building for persons with a disability and other sectors of the population including the elderly, who at times require the same provisions as persons with a disability. Following a review of the 1997 Design Manual together with the legislation, legal framework and administration, it has been identified that while Hong Kong’s existing principal and subsidiary legislation caters for some of the needs of persons with a disability, it does not adequately address the specific needs of the elderly in terms of spatial requirements and facilities.
3. In the next 20 to 30 years we will see a significant demographic shift in the population of Hong Kong with a greater proportion of the elderly. It must be acknowledged that persons with a disability and the elderly are as much a part of our society as everyone else, would require better integration of facilities for barrier free access. During the review of the “Design Manual: Barrier Free Access 1997”, some of the standards in providing more reasonable and clearer guidelines have been re-examined. Those provisions that were open to interpretation have been refined to remove any possible ambiguities. Those provisions that were considered not necessary have been proposed to be relaxed after considering local conditions and users’ requirements. In addition, the scope of the Manual has also been expanded to include provision of facilities for the elderly to enhance their health and safety and to facilitate their movement within buildings.
4. The “barrier-free” design requirements, newly introduced design considerations and recommended design requirements aim to facilitate greater independence of not only persons with a disability and the elderly but also people with other forms of physical infirmities or limitations such as pregnant women, families with young children. It is intended that the implementation of this Design Manual will result in greater awareness of the public, professionals and developers who will come to appreciate the value of making the built-environment more accessible and friendly to as broad a spectrum of our community as possible.

CHAPTER 1

FOREWORD

- 1.1 The Disability Discrimination Ordinance was enacted in August 1995. It prohibits, among other things, discrimination against persons with a disability by failing to provide means of access to any premises that the public or a section of the public is entitled or allowed to enter or use, or by refusing to provide appropriate facilities. However, there is no discrimination in relation to the provision of access to premises if the premises are so designed or constructed as to be inaccessible to persons with a disability and any alteration to the premises to provide such access would impose unjustifiable hardship on the persons who would have to provide it. A person who believes he or she has been discriminated against in relation to access to premises or the provision of facilities may lodge a complaint with the Equal Opportunities Commission or may institute legal proceedings in the court. Reference may be made to this Manual as one sees fit in considering whether it is reasonable to require the provision of such access or facilities.
- 1.2 For a new building or for the alterations or additions to an existing building, section 84 of the Disability Discrimination Ordinance stipulates that: -

“84. Building approvals

- (1) *Notwithstanding any provision in any other Ordinance (whether enacted before or after the commencement of this Ordinance) but subject to subsection (3), a public authority which has the power to approve building works shall not, in respect of those works, approve building plans, whether for a new building or for the alterations or additions to an existing building unless the person seeking approval satisfies the public authority that such access as is reasonable in the circumstances to the building or premises will be provided for persons with a disability.*
- (2) *In considering whether reasonable access will be provided under subsection (1), the public authority may taken into account: -*
- (a) *whether it is practicable to provide such access within the curtilage of the building, bearing in mind the physical location and immediate environs of the building; and*
 - (b) *whether providing such access would impose unjustifiable hardship on the person seeking approval or on any other person.*
- (3) *Subsection (1) has no application to: -*
- (a) *buildings of 13 m or less in height above ground level which are used, or intended to be used, for occupation by a single family; or*
 - (b) *temporary buildings or contractor's sheds referred to in Part VII of the Building (Planning) Regulations (Cap. 123 sub. leg.).*

1.2 (Cont'd)

(4) *In this section, "public authority" includes: -*

- (a) *the Director of Lands;*
- (b) *the Building Authority;*
- (c) *the Housing Authority;*
- (d) *the Director of Architectural Services."*

1.3 This Manual applies to the design and construction of new private buildings or substantial alterations and additions to existing private buildings. Relevant Government authorities and departments will also refer to it in the design and construction of government and public buildings.

1.4 To ensure effective enforcement, the following obligatory design requirements of this Manual are put into the following legislation: -

Legislation	Obligatory Design Requirements
Building (Planning) Regulations	3.1.3 for auditorium and backstage facilities 3.2.3 for hotels, hostels and guesthouses 3.3.3 for carparks 4.1.3 for access 4.2.3 for ramps 4.3.3 for dropped kerbs 4.4.3 for steps and staircases 4.5.3 for handrails 4.6.3 for corridors, lobbies and paths 4.7.3 for doors 4.8.3 for toilets and W.C. cubicles 4.9.3 for bathrooms and shower compartments 4.10.3 and 4.10.4 for signs 4.11.3 for information/service counters 5.2.3 for illumination 5.4.3 for emergency alarm in accessible toilets 5.6.3 for assistive listening systems 5.7.3 (a), (b), (c), (d), (e), (g), (h), (i), (j), (k) and (l) and 5.8.3 for lifts 5.9.3 for escalators/passenger conveyors

For those obligatory design requirements which are not put into legislation, they are incorporated into the following codes of practice –

Code of Practice	Obligatory Design Requirements
COP for Minimum Fire Service Installations and Equipment and Inspection, Testing and Maintenance of Installations and Equipment deemed to satisfy the requirements of the Director of Fire Services for the purpose of complying with Section 16(1)(b) of the Buildings Ordinance (Cap. 123)	5.3.3 for visual alarm and audible alarm.
COP on the Design and Construction of Lifts and Escalators and COP for Lift Works and Escalator Works deemed to satisfy Lifts and Escalators (Safety) Ordinance (Cap. 327)	5.7.3 (f), (m) and (n) for passenger lifts.

CHAPTER 2

EXTENT OF APPLICATION AND DEFINITIONS

2.1 EXTENT OF APPLICATION

2.1.1 The requirements set out in this Manual are classified into: -

(a) Mandatory Section

- Performance Objectives

The Performance Objectives are guiding principles for the design and construction of the building or building works in the provision of barrier free access. Compliance with the Obligatory Design Requirements will achieve the Performance Objectives. Where alternative designs are proposed in lieu of strict compliance with the Obligatory Design Requirements, such alternative designs must be able to achieve the relevant Performance Objectives.

- Obligatory Design Requirements

Compliance with the Obligatory Design Requirements is mandatory and is deemed to satisfy the requirements put into legislation and codes of practice, unless otherwise modified or exempted.

(b) Best Practice Section

- Design Considerations

These are considerations to improve provisions leading to better and more convenient access and facilities. The considerations should facilitate efficient and effective access, and promote greater awareness to professionals and building owners for building more friendly and accessible built-environment for all its intended users.

- Recommended Design Requirements

These standards are included for the reference of professionals and building owners who intend to provide access and/or special facilities that are enhanced from the Obligatory Design Requirements for the use by all intended users.

2.1.2 Subject to **Section 2.2 “Exemption”**, a new building or any substantial alterations or additions to an existing building shall be designed in accordance with the Mandatory Section set out in this Manual provided that: -

(a) the means of access and facilities stipulated in the Mandatory Section shall be provided to the categories of buildings specified in the left column of **Table 1** and to the extent specified in the right column thereof: and

(b) the extent of application of additional assistive provisions to various uses of buildings shall be as specified in **Table 2**.

2.1 EXTENT OF APPLICATION

TABLE 1

CATEGORY OF BUILDINGS & EXTENT OF THE APPLICATION OF DESIGN MANUAL	
<u>Category of Buildings</u>	<u>Extent of application of this Manual</u>
Domestic buildings	<ul style="list-style-type: none">- All common areas of buildings of more than four (4) storeys.- Main entrance and common area of the ground floor and means of access to buildings which do not exceed four (4) storeys.
Non-domestic buildings	<ul style="list-style-type: none">- Non-domestic parts of such building.
Composite buildings	<ul style="list-style-type: none">- Non-domestic parts of such building.- All common areas of the domestic parts of such building, if the domestic parts exceed four (4) storeys.- Main entrance and common area of the ground floor and means of access thereto, if the domestic parts do not exceed four (4) storeys.

2.1 EXTENT OF APPLICATION (Cont'd)

TABLE 2

“Y” denotes “Applicable”

“-“ denotes “Not Applicable”

EXTENT OF APPLICATION OF ADDITIONAL ASSISTIVE PROVISIONS TO VARIOUS USES OF BUILDINGS						
Uses of buildings	Required Additional Assistive Provisions listed below: -					
	Braille & tactile layout plan [4.10.4(a)]	Tactile guide path [4.1.3(c)] [4.10.4(b)]	Visual Display Board [4.10.4(c)]	Accessible Public Information / Service Counter [4.11.3(a)]	Visual Fire Alarm System [5.3.3]	Assistive Listening System with International Sign [5.6.3(a)]
1. Domestic use	-	-	-	-	-	-
2. Common areas of Office	-	-	-	-	Y	-
3. Department store and shopping complex	Y	Y	-	Y	Y	-
4. Hotel, guest house, hostel and bank	Y	-	-	Y	Y	-
5. Place for worship	Y	-	-	Y	Y	-
6. Cinema, theatre, concert hall, stadium, museum, theme park and purpose-built family amusement centre	Y	Y	Y	Y	Y	Y
7. School, college, university and public library	Y	Y	-	Y	Y	-
8. Factory, workshop and place for industrial use	-	-	-	-	Y	-
9. Sports complex and public swimming pool complex	Y	Y	-	Y	Y	-
10. Restaurant and food court	Y	-	-	-	Y	-
11. Indoor market and supermarket	Y	-	-	-	Y	-

2.1 EXTENT OF APPLICATION (Cont'd)

TABLE 2 (Cont'd)

EXTENT OF APPLICATION OF ADDITIONAL ASSISTIVE PROVISIONS TO VARIOUS USES OF BUILDINGS						
Uses of buildings	Required Additional Assistive Provisions listed below: -					
	Braille & tactile layout plan [4.10.4(a)]	Tactile guide path [4.1.3(c)] [4.10.4(b)]	Visual Display Board [4.10.4(c)]	Accessible Public Information / Service Counter [4.11.3(a)]	Visual Fire Alarm System [5.3.3]	Assistive Listening System with International Sign [5.6.3(a)]
12. Hospital, purpose-built clinic	Y	Y	Y	Y	Y	Y
13. Residential home for the elderly and welfare centre	Y	Y	-	Y	Y	-
14. Club house	Y	-	-	Y	Y	-
15. Transport station, interchange, passenger terminal	Y	Y	Y	Y	Y	Y
16. Carpark	Y	-	-	-	Y	-

2.2 EXEMPTIONS

2.2.1 The Obligatory Design Requirements shall not apply to the following buildings: -

- (a) Buildings of 13 m or less in height above ground level which are used, or intended to be used, for occupation by a single family; or
- (b) Temporary buildings or contractor's sheds referred to in Part VII of the Building (Planning) Regulations (Cap.123 sub. leg.).

2.2.2 The Obligatory Design Requirements shall not apply to the following areas or parts of a building as there is a relatively high risk to persons with a disability in these areas/parts :-

- (a) Commercial kitchen, cold room and cinema projector room.
- (b) Area only used for building services and maintenance (testing, inspection, verification, repair and overhaul) including: -
 - (i) plant, cooling tower and power plant;
 - (ii) equipment and lift motor room, and electrical transformer room and switch room, battery room, machinery room, plant room and pump room;
 - (iii) boiler room;
 - (iv) non-tenantable spaces accessed only by ladder, catwalk, crawl space;
 - (v) access route for maintenance, pit, lift shaft and ventilation shaft; and
 - (vi) sub-station, telecommunication equipment room, metering area, or the like.
- (c) Area used for storage of raw material, produce or for bulk storage where:
 - (i) the stored material is hazardous; or
 - (ii) the public is not permitted to enter, such as waste containment area, chemical store, or the like.
- (d) Mezzanine floor used only for storage, plant and equipment installation or the like.
- (e) Raised platform used primarily for purpose of security or safety management, including, but not limited to, guard tower or fixed lifeguard stand.
- (f) Swimming pool (the water containing pool only).
- (g) Any path providing access only to an exempted area.

2.3 DEFINITIONS

For the purpose of this Manual, the following terms are defined as: -

“Access” is means to enable persons with or without a disability to approach, enter and leave the building and to use the facilities therein without assistance or undue difficulties.

“Accessible” describes a site, building, facility or portion thereof that is barrier-free, can be approached, entered and used by persons with or without a disability and complies with this Manual.

“Accessible lift” means lift fully complied with the obligatory design requirements in Section 5.7.

“Accessible route” is a continuous unobstructed path which is easily identifiable for persons with a disability or the elderly to approach, enter and leave the building and to use the facilities therein without assistance and undue difficulties.

“Assistive listening system” means a system which enables sound signals to be transmitted to persons with hearing impairment without interference from background noise or excessive reverberation.

“Braille” refers to Cantonese Braille for providing Braille information to persons with visual impairment or the blind.

“Common areas” are those areas open to and available for the common use and enjoyment of all occupiers of the building.

“Luminous contrast” means the amount of light reflected from the surface of the object compared to the amount of light reflected from the surface of its surrounding background. Such contrast expressed in percent can be determined by:

$$[(B1-B2) / B1] \times 100$$

Where

B1 = light reflectance value (LRV) of the lighter area and

B2 = light reflectance value (LRV) of the darker area.

[Sources from AMERICANS WITH DISABILITIES ACT ACCESSIBILITY GUIDELINES (ADAAG)]

2.3 DEFINITIONS (Cont'd)

“Persons with ambulant disabilities” are persons with ambulant impairment who may require the aid of devices such as prostheses, orthoses, sticks or crutches for walking.

“Persons with a disability” means persons who on account of injury, disease, or congenital deformity, are impaired in vision, hearing or locomotion. Such persons shall include persons with ambulant disabilities, wheel-chair users, persons with visual impairment, the blind, persons with hearing impairment and the deaf.

“Required staircase” means an access staircase in a firefighting and rescue stairway or a staircase required for means of escape in case of fire.

“Tactile guide path” means a standardized pattern applied to or built onto walking surfaces through the combined use of tactile directional tiles / blocks, positional tiles / blocks and tactile warning tiles / blocks for way finding and orientation for persons with visual impairment or the blind.

“Unjustifiable Hardship” has the same meaning as ‘unjustifiable hardship’ referred to in section 4 of the *Disability Discrimination Ordinance Cap. 487*, which reads :

*‘For the purposes of this Ordinance in determining what constitutes **unjustifiable hardship**, all relevant circumstances of the particular case are to be taken into account including: -*

- (a) *the reasonableness of any accommodation to be made available to a person with a disability;*
- (b) *the nature of the benefit or detriment likely to accrue or be suffered by any persons concerned;*
- (c) *the effect of the disability of the person concerned; and*
- (d) *the financial circumstances of and the estimated amount of expenditure (including recurrent expenditure) required to be made by the person claiming unjustifiable hardship.’*

“Wheelchair users” are those persons who depend on wheelchairs for mobility.

CHAPTER 3

ACCESSIBLE PROVISIONS FOR SPECIAL AREAS

3.1 AUDITORIUM AND BACKSTAGE FACILITIES

3.1.1 This section is applicable to the auditorium for audience and backstage facilities of theatre, cinema, concert hall, gymnasium, games hall, sports stadium and other entertainment related premises as well as lecture and conference facilities.

MANDATORY SECTION

3.1.2 Performance Objectives

The seating areas of an auditorium, the stage and backstage facilities, shall be provided with safe and convenient access for all people including persons with a disability.

3.1.3 Obligatory Design Requirements

Wheelchair Spaces

- (a) A minimum of four wheelchair spaces shall be provided at spectator level in the auditorium. Two wheelchair spaces shall be provided for every 400 fixed seats and any part thereof. (For example, at least six wheelchair spaces shall be provided if there are 900 fixed seats.) The spaces shall be grouped in pairs (not less than two) and also not separated from the seats for other audiences. Each wheelchair space shall have unobstructed line of vision to the stage areas, and be of minimum size of 800 mm x 1300 mm, with the side of 800 mm facing towards the stage podium or screen. The minimum width of the crossover shall not be less than 1500 mm. (See **Figure 1A**)

Readily removable seats can be installed in wheelchair spaces when the spaces are not occupied by wheelchair users.

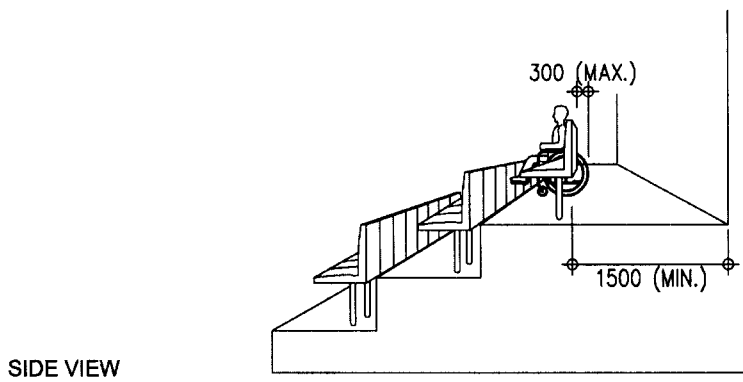
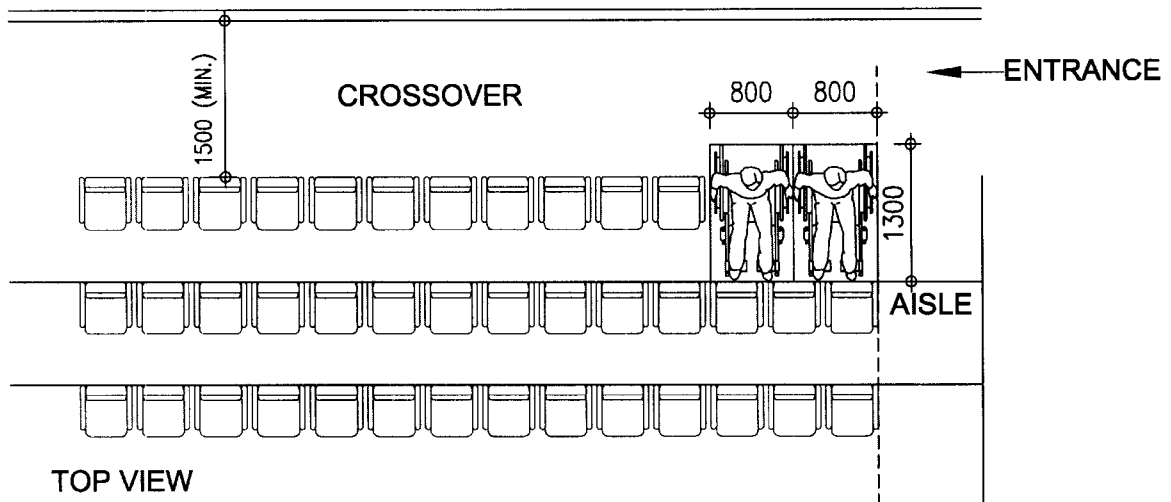

*ALL DIMENSIONS ARE IN mm

Figure 1A – Wheelchair Space in an Auditorium

3.1.3 Obligatory Design Requirements (Cont'd)

Access for Wheelchair Users

- (b) The auditorium, the stage, backstage facilities, changing rooms, rehearsal rooms, dressing rooms, rest rooms, toilets and shower rooms shall be accessible to wheelchair users. If there is an access connecting any of them, an equivalent accessible route shall be provided for wheelchair users, e.g. by a ramp in compliance with **Section 4.2**, an accessible lift in compliance with **Sections 5.7 and 5.8**, or a vertical lifting platform in compliance with **Section 5.10**.

Tactile Warning Strips

- (c) Tactile warning strips complying with **Clause 4.4.3 (b)** shall be provided at both the top and bottom of the staircases leading to the stage.

Braille and Tactile Maps

- (d) Braille and tactile fire exit maps as shown in **Figure 32** shall be provided at all entrances to the auditorium.

BEST PRACTICE SECTION

3.1.4 Design Considerations

- (a) Seating allocation for persons with a disability should be accessible by provision of a direct, easily identifiable route free from obstructions, and preferably adjacent to the means of egress and accessible toilets.
- (b) The wheelchair spaces should be so located that the wheelchair user may have the choice of sitting with another wheelchair user or conventionally seated companion.
- (c) The lines of sight provided by the wheelchair spaces should be comparable to those of other normal viewing positions.
- (d) It is a good practice to provide wheelchair spaces at different levels of the seating area in order to have a variety of viewing locations. An example of wheelchair space arrangement is shown in **Figure 1B**.
- (e) Safety barrier should be provided to wheelchair spaces located at high level to minimise the risk of the wheelchair falling over the edge.

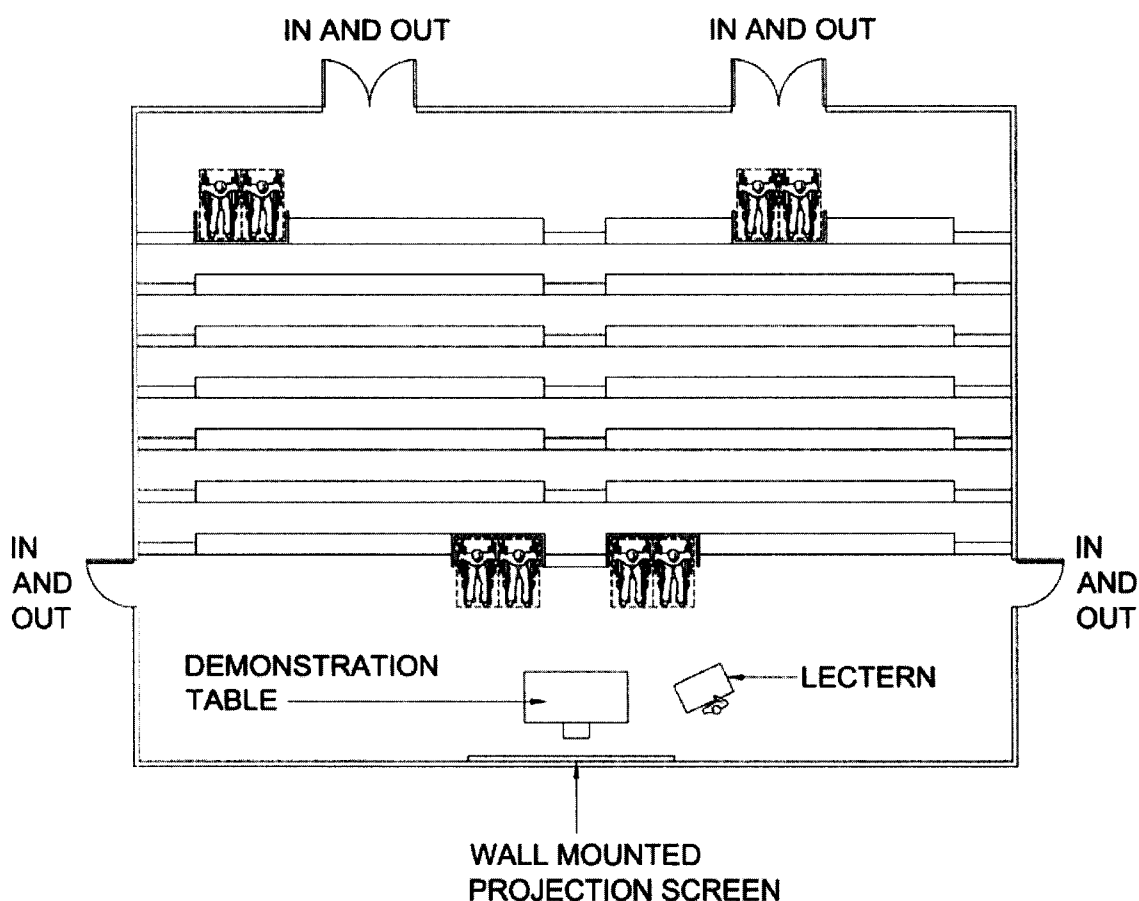

Figure 1B – Example of Wheelchair Spaces in a Lecture Theatre

3.1.5 Recommended Design Requirements

- (a) A conventional companion seat may be provided next to each wheelchair seating location.
- (b) Removable seats may be provided in wheelchair seating locations for spare use by persons other than wheelchair users.
- (c) Access should be provided to the low and high levels of the auditorium.
- (d) Two to three rows of removable seats should be provided in the auditorium for the use by large group of wheelchair users for special function / occasions.
- (e) Where conventional seat numbers are provided, Braille and tactile seat number should be provided at the top of each seat rest. The specification of Braille cells is provided in **Figure 31**.
- (f) Sound enhancement system may be provided at the designated areas for persons with hearing impairment.

3.2 HOTELS, HOSTELS AND GUESTHOUSES

3.2.1 This section is applicable to guest rooms designated for the use of persons with a disability in hotels, hostels and guesthouses.

MANDATORY SECTION

3.2.2 Performance Objectives

The accessible guest rooms provided in a hotel, hostel or guesthouse shall be accessible by persons with a disability not only to the rooms but also to all sleeping, bathing and sanitary facilities in the rooms.

3.2.3 Obligatory Design Requirements

Minimum Provision

- (a) A minimum of two guest rooms with full facilities for persons with a disability shall be provided in a hotel, hostel and guesthouse. Two such rooms shall be provided for every 100 guest rooms and any part thereof. (For example, a total of four such rooms shall be provided if there are 150 guest rooms.)
- (b) The bathroom and shower facilities serving an accessible guest room shall comply with **Section 4.9**.

BEST PRACTICE SECTION

3.2.4 Design Considerations

- (a) Within an accessible guest room, wheelchair user should be able to manoeuvre around and use the facilities in the room, and operate switches and controls. The internal layout should be large enough to enable a wheelchair user to transfer to one side of a bed, with or without assistance.
- (b) In addition, it is important to ensure that the built-in wardrobes and shelving in all guest rooms are accessible and convenient to use.

3.2.5 Recommended Design Requirements

- (a) A typical guest room layout is shown in **Figure 2** and typical bathroom and shower compartment are shown in **Figure 27**.

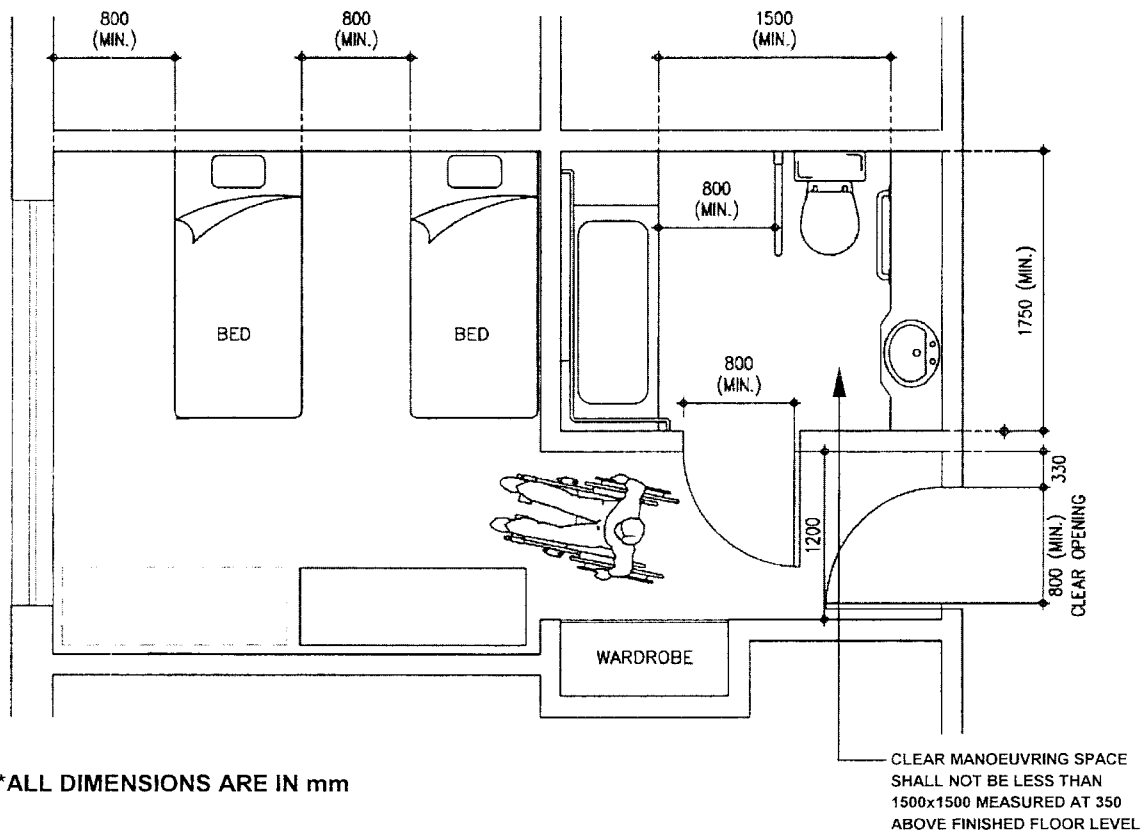

Figure 2 – Typical Guest Room Layout

3.3 CARPARKS

3.3.1 This section aims to provide standards for accessible car parking spaces designated for the use of persons with a disability.

MANDATORY SECTION

3.3.2 Performance Objectives

Adequate numbers of accessible car parking spaces shall be provided with proper access, proper designation and directional signage in the carparks.

3.3.3 Obligatory Design Requirements

- a)
- | Total No. of Car Parking Space in Lot | Required No. of Accessible Car Parking Spaces |
|---------------------------------------|---|
| 1-50 | 1 |
| 51-150 | 2 |
| 151-250 | 3 |
| 251-350 | 4 |
| 351-450 | 5 |
| Above 450 | 6 |
- (b) The parking spaces reserved for persons with a disability shall be located in proximity and with an accessible route to the lobby with an accessible lift or entrance.
- (c) The minimum width for a parking space for persons with a disability shall be 3500 mm. The parking space shall be clearly marked with the international symbol of accessibility and the parking space number on the floor as shown in **Figure 3**.
- (d) A common loading/unloading area of at least 1200 mm wide between two parking spaces for persons with a disability may be allowed if space is limited. The common area shall be marked with yellow hatched markings as shown in **Figure 4**.

SPACE RESERVED FOR PERSONS WITH A DISABILITY SHALL BE MARKED WITH THE INTERNATIONAL SYMBOL OF ACCESSIBILITY AND PARKING SPACE NUMBER

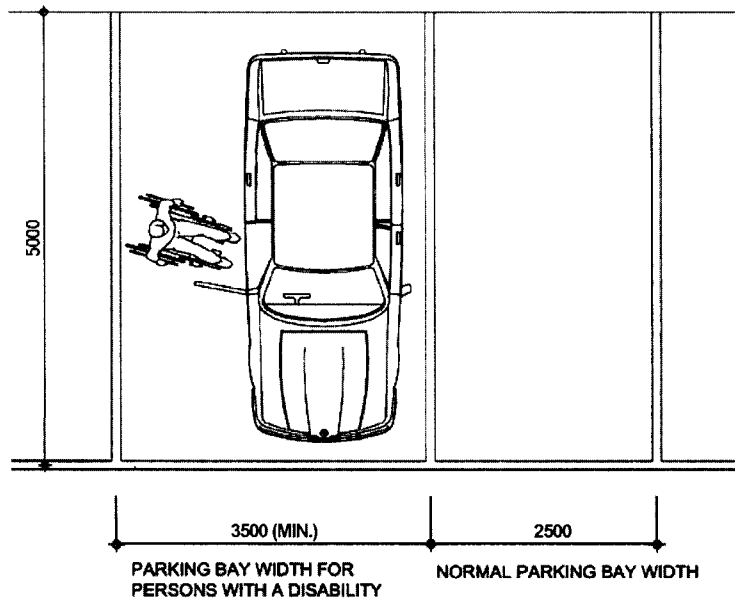
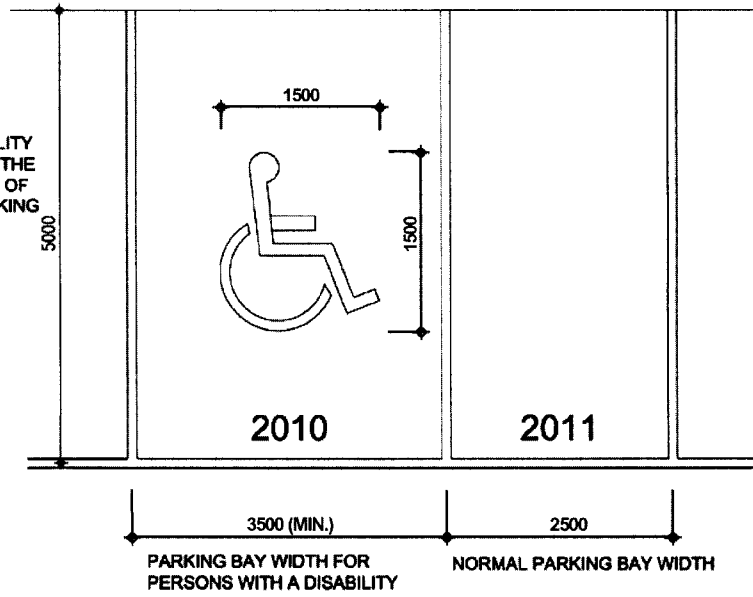

*ALL DIMENSIONS ARE IN mm

Figure 3 – Dimension and Identification of Car Parking Space for Persons with a Disability

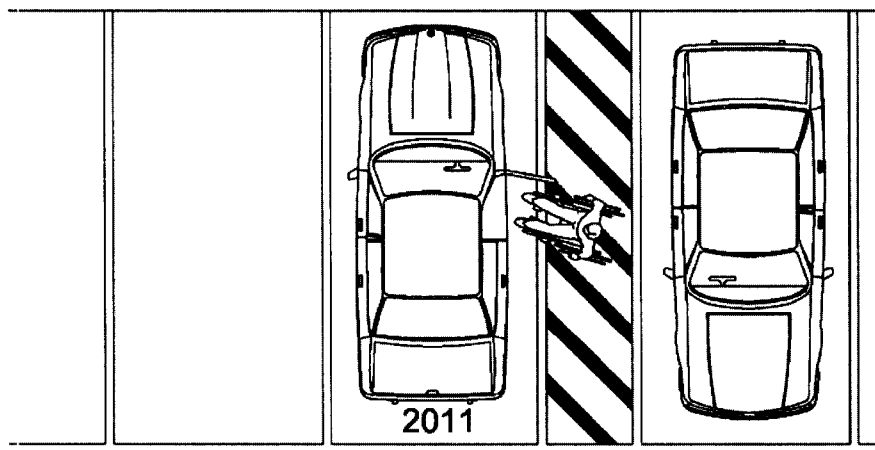
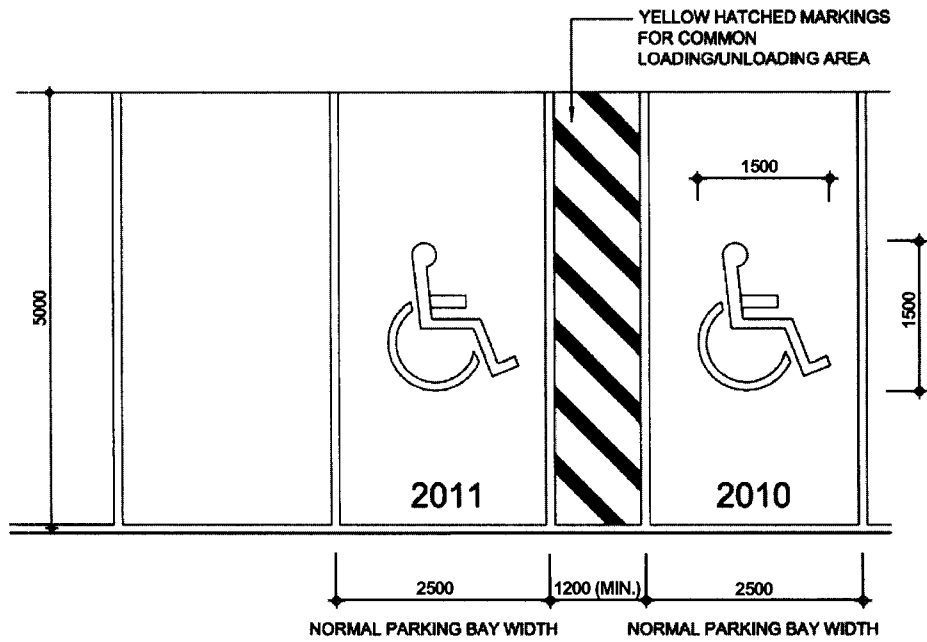

VEHICLES MUST PARK IN ALTERNATE DIRECTIONS IN ORDER TO UTILIZE HATCHED AREA

*ALL DIMENSIONS ARE IN mm

Figure 4 – Side by Side Parking Spaces for Persons with a Disability

BEST PRACTICE SECTION

3.3.4 Design Considerations

- (a) Persons with ambulant impairment who arrive as passengers should be able to alight conveniently from a vehicle close to the principal entrance, or alternative accessible entrance, of the building.
- (b) The parking bay surface should allow the safe transfer of a passenger or driver to a wheelchair and transfer from the parking bay to the access route to the building without undue effort, barriers to wheelchairs or hazards from tripping.
- (c) Where a ticket dispensing machine is installed, it should be located properly to allow wheelchair users, or persons of short stature, to approach conveniently to the machine and perform the payment and ticket dispensing functions.

3.3.5 Recommended Design Requirements

- (a) At the entrance of public parking facilities, signage should be displayed in prominent positions to indicate the designated numbers of the parking spaces reserved for persons with a disability (see **Figure 5**).
- (b) Indication / directional signage along driveway showing the way leading to the parking spaces reserved for persons with a disability should be provided.

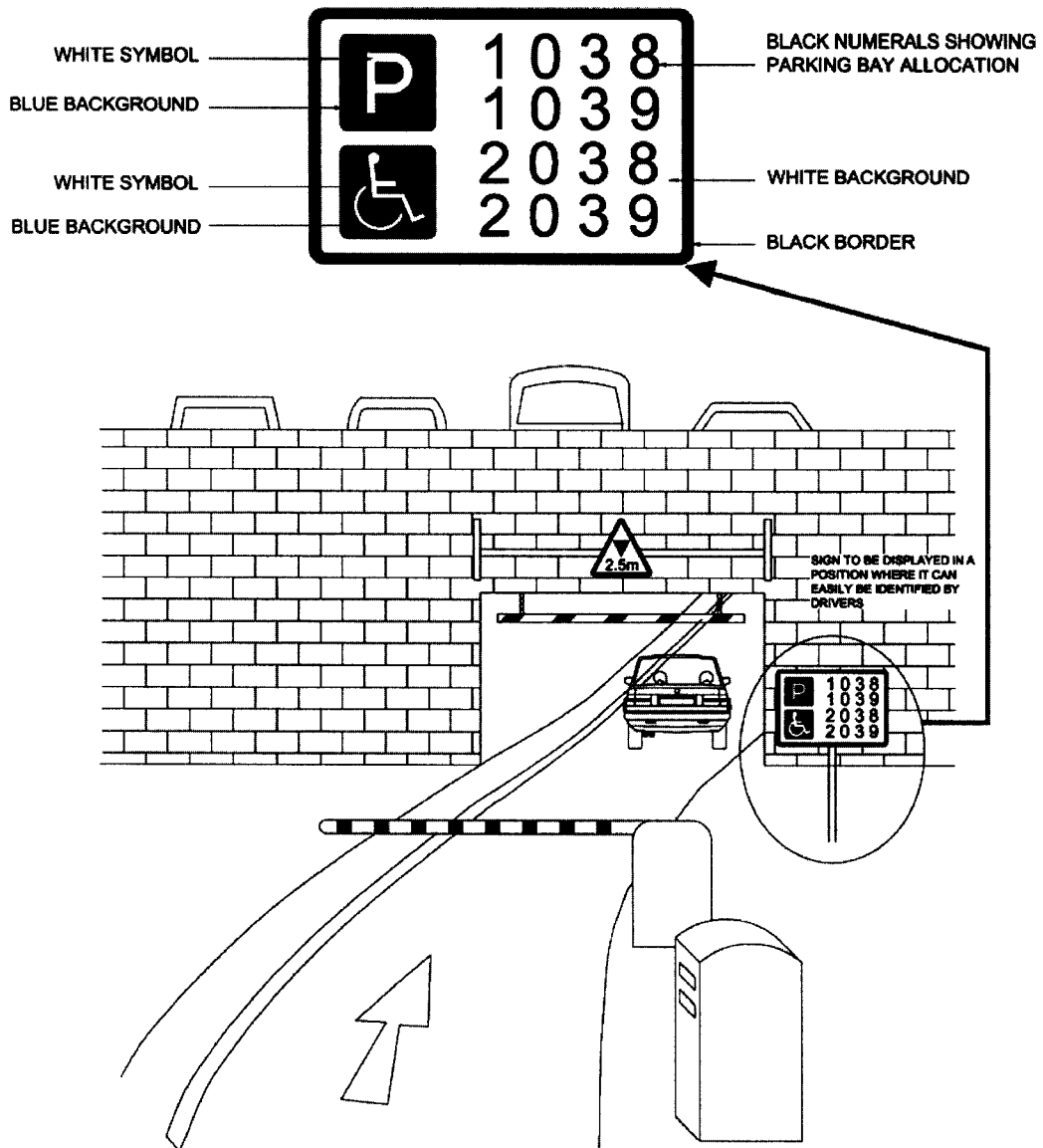

Figure 5 – Parking Space Indication Signage

CHAPTER 4

GENERAL DESIGN REQUIREMENTS

4.1 ACCESS

4.1.1 This section aims to ensure proper access for all people, with or without disabilities to approach, enter or leave a building independently to reach and use its facilities, such as foyers, lifts, toilets, shops, restaurants, cinemas, etc. without undue difficulty.

MANDATORY SECTION

4.1.2 Performance Objectives

An easily identifiable continuous and relatively level path free from obstruction or any kind of hazards shall be provided for persons with a disability to enter, move within and leave a building to reach the accessible facilities.

4.1.3 Obligatory Design Requirements

Orientation and Width

(a) Access shall be provided from a prominent point or points on the lot boundary, which is accessible to a public street or pedestrian way, directly to at least one entrance which is commonly used by the public or to a point directly adjacent to one entrance which is commonly used by the public and to an accessible lift, unless it is impractical to do so because of difficult terrain or unusual characteristics of the site. The clear width of the access route shall not be less than 1050 mm.

In case where the main entrance is not an accessible entrance or it is impractical to provide a commonly used entrance at prominent point on the lot boundary due to difficult terrain or unusual characteristics of the site (e.g. in the case of a sloping site or presence of steep access road/driveway), this would be acceptable provided that persons with a disability could reach the building by means of vehicle and adequate directional signs shall be posted at conspicuous location of the main entrance to show clearly the location of and the route to an accessible entrance.

Free from Barriers

(b) Such access shall be free from protrusion hazards, steps, kerbs other than dropped kerbs, steep ramps, doors or doorways which will impede the passage of a wheelchair, or other form of barrier which will prevent access by persons with a disability.

Tactile Guide Path

(c) For categories of buildings as required in **Table 2**, such access shall be provided with a tactile guide path as illustrated in **Figures 6A and 6B**. Examples of specification of tactile tile are shown in **Figure 6C**.

Surface

(d) The surface of the access shall be firm.

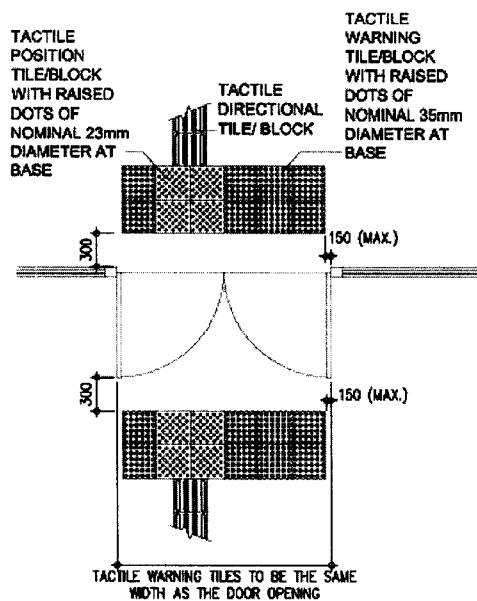

(a) Tactile warning strip at single action door entrance

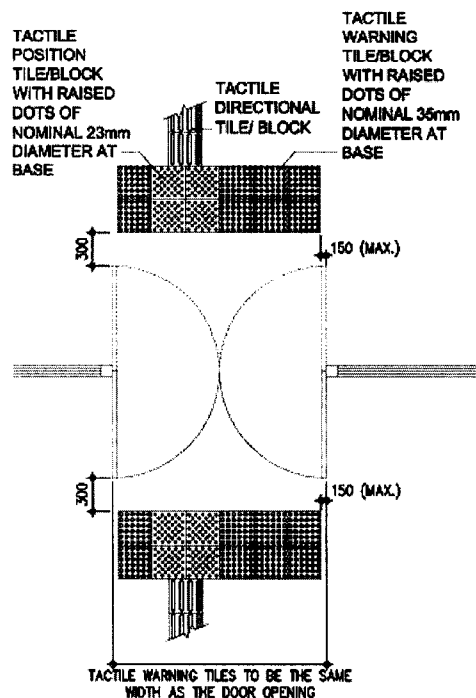

(b) Tactile warning strip at double action door entrance

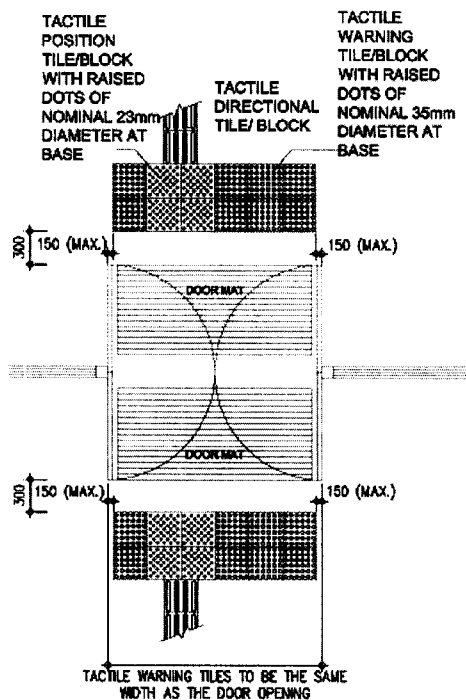

(c) Tactile warning strip at door entrance with floor mats

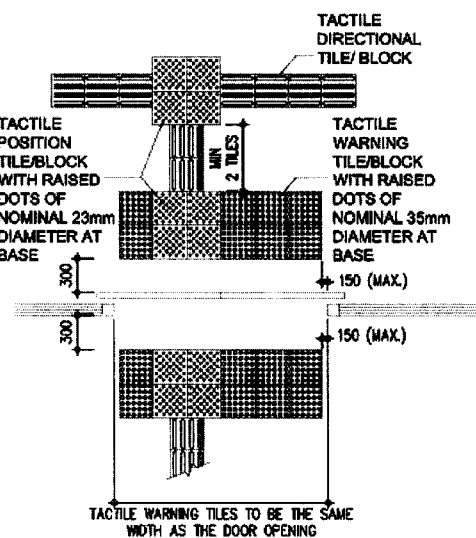

(d) Tactile paving at sliding door entrance

*ALL DIMENSIONS ARE IN mm

Figure 6A – Tactile Guide Paths at Building Entrances Linking up with Initial Access on the Lot Boundary and Interior Facilities

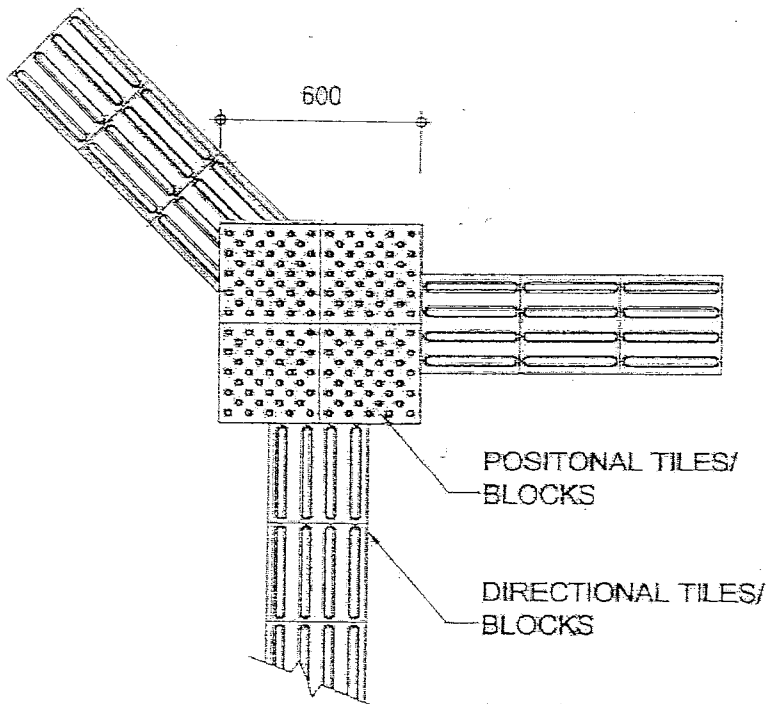
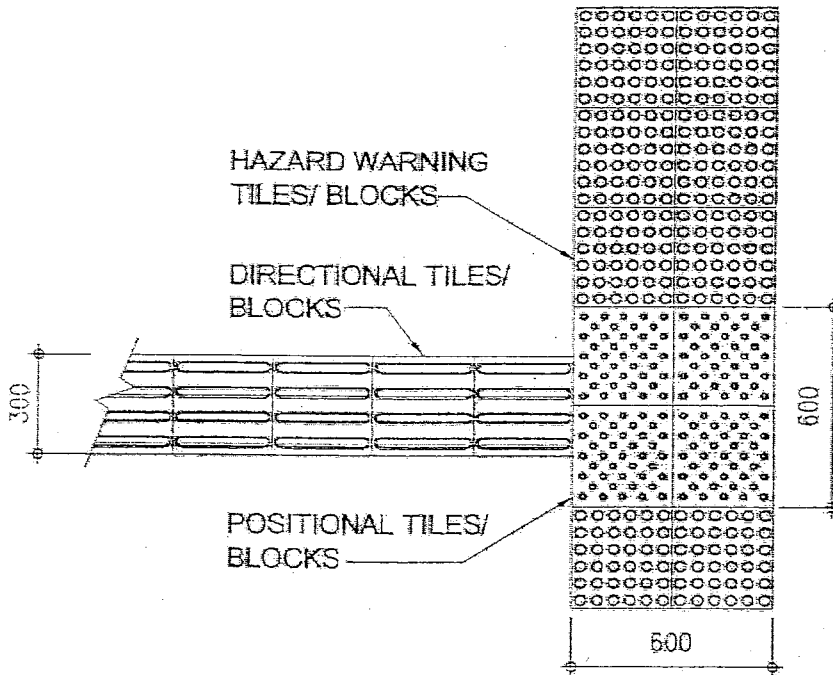

*ALL DIMENSIONS ARE IN mm

Figure 6B – Typical Tactile Guide Path Junction

Three kinds of tactile tiles/blocks as shown in Figure 6C are commonly used in constructing a tactile guide path:

i) Directional Tile/Block

This has parallel raised bars for guiding the users along an intended safe path.

ii) Hazard Warning Tile/Block

This has raised big dots (35mm in diameter arranged in square grid parallel to the sides of the slab for indication of potential hazards ahead. This type of tile/block could be used alone to form tactile warning strips at the top and bottom of staircase or ramps, and at dropped kerb.

iii) Positional Tile/Block

This has raised small dots (23mm in diameter) placed in staggered positions for indication of possible change in walking directions.

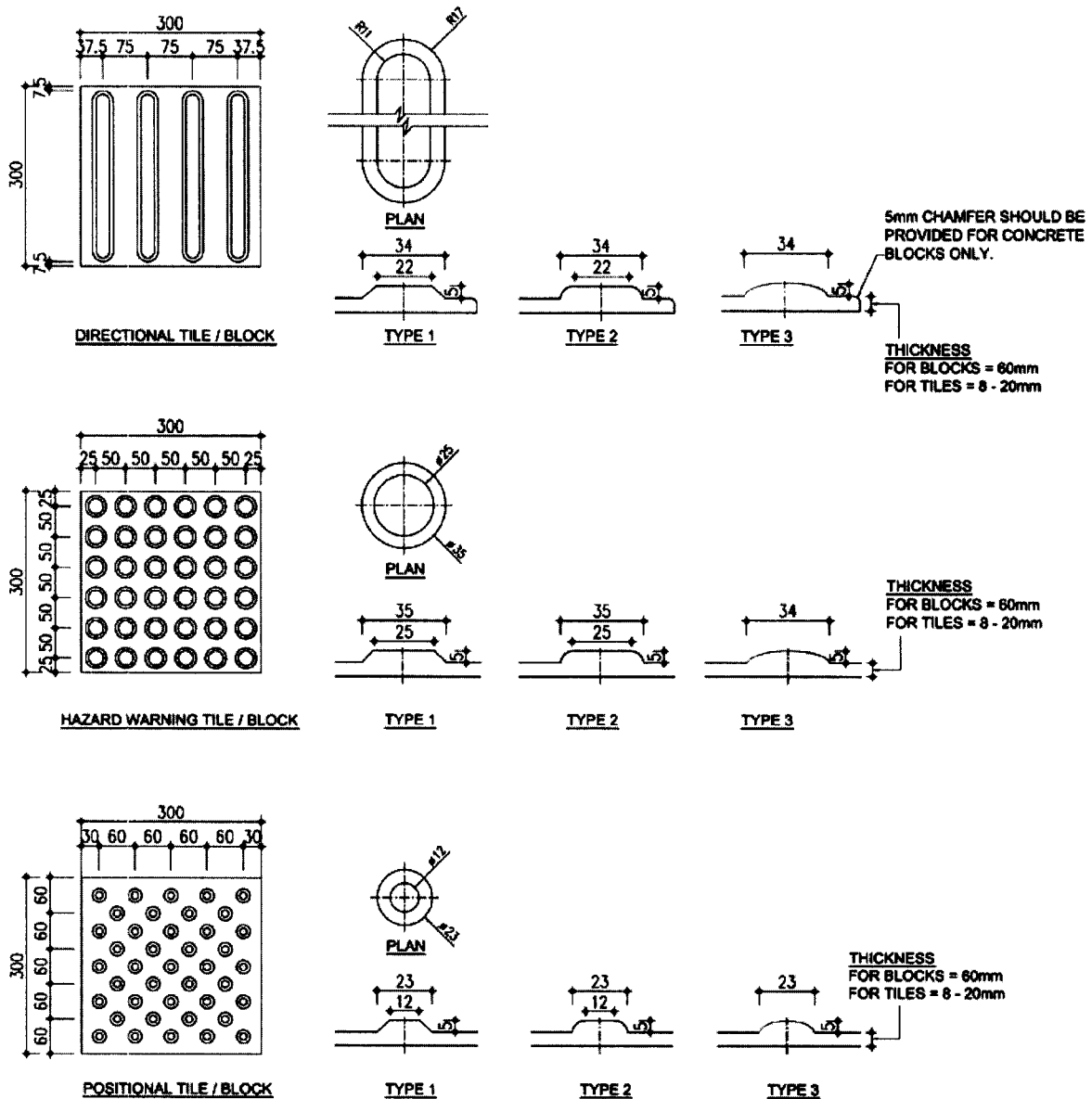

*ALL DIMENSIONS ARE IN mm

Figure 6C – Examples of Details of Tactile Warning Tiles / Blocks

BEST PRACTICE SECTION

4.1.4 Design Considerations

- (a) In designing an access to the building, it should be recognised that changes in level are difficult for many people to negotiate, including wheelchair users, people who use walking aids and persons with visual impairment.
- (b) Access routes from the lot boundary to the entrance of a building should be wide enough to allow wheelchair users and other users to pass simultaneously.
- (c) Easily identifiable access route e.g. tactile guide path for persons with visual impairment should be provided from the lot boundary to the entrance of a building.
- (d) Indication signage for accessible entrances should be provided where more than one entrance exist in a complex building.

4.1.5 Recommended Design Requirements

Width

- (a) The clear width of the access route should not be less than 1500 mm.

Floor Space

- (b) In large floor space of more than 200m² where the cues of physical edges such as walls and handrails are not present, tactile guide paths should be used to facilitate orientation of persons with visual impairment.

Surface

- (c) The surface of the access should be firm and slip-resistant with a static “coefficient of friction” of “Good” grading (**see Appendix C**).

4.2 RAMPS

4.2.1 A ramp is a sloping walkway leading from one level to another.

MANDATORY SECTION

4.2.2 Performance Objectives

Ramps of an appropriate design shall be provided at all changes in level other than those served by an accessible lift or accessible lifting mechanism accommodating the specific requirements of persons with a disability.

4.2.3 Obligatory Design Requirements

Width

(a) A ramp shall not be less than 1050 mm in width.

Landing

(b) A clear space of not less than 1500 mm x 1500 mm shall be provided at the head and foot of every ramp, i.e. door swing and alike shall not be allowed to swing onto the landing.

Running Slope and Length

(c) No ramp shall be steeper than 1 in 12 gradient except in the following situations of minor rise :-

Maximum slope	Maximum length	Maximum rise
1:10 i.e., 10%	1500mm	150mm
1:8 i.e., 12.5%	600mm	75mm

(d) Combination of ramps of minor rise as stated in **Clause 4.2.3(c)** shall not be permitted.

(e) If the gradient of a ramp is 1 in 20 or steeper, the ramp shall be provided with :-

(i) a landing of not less than 1200 mm long for each 10 m length of horizontal run or part thereof; (**Figure 7**)

(ii) handrails complying with **Section 4.5** on both sides; and

(iii) tactile warning strips at the head, foot and landings (**Figure 7**).

The above items shall not apply to ramp access to lift or ramp with a length less than 300 mm.

(f) Any ramp with a rise greater than 200 mm, leading down towards an area where there may be vehicular traffic, shall have a railing or barrier across the full width of its lower end, and be not less than 1500 mm from the foot of the ramp.

4.2.3 Obligatory Design Requirements (Cont'd)

Surface and Protection

- (g) Raised traction strip shall be avoided.
- (h) A kerb of at least 100 mm high, or a rail 200 mm above ramp level shall be provided on both sides to prevent wheelchair from slipping over the edge.
- (i) No appliances, fixtures and fittings shall project beyond 90 mm from the surface of any wall below a level of 2000 mm above the ramp level unless they are unavoidable, in which case they shall also be extended downwards to the ramp level or be guided by tactile flooring materials.
- (j) The floor and wall along ramps shall be in contrasting colours.

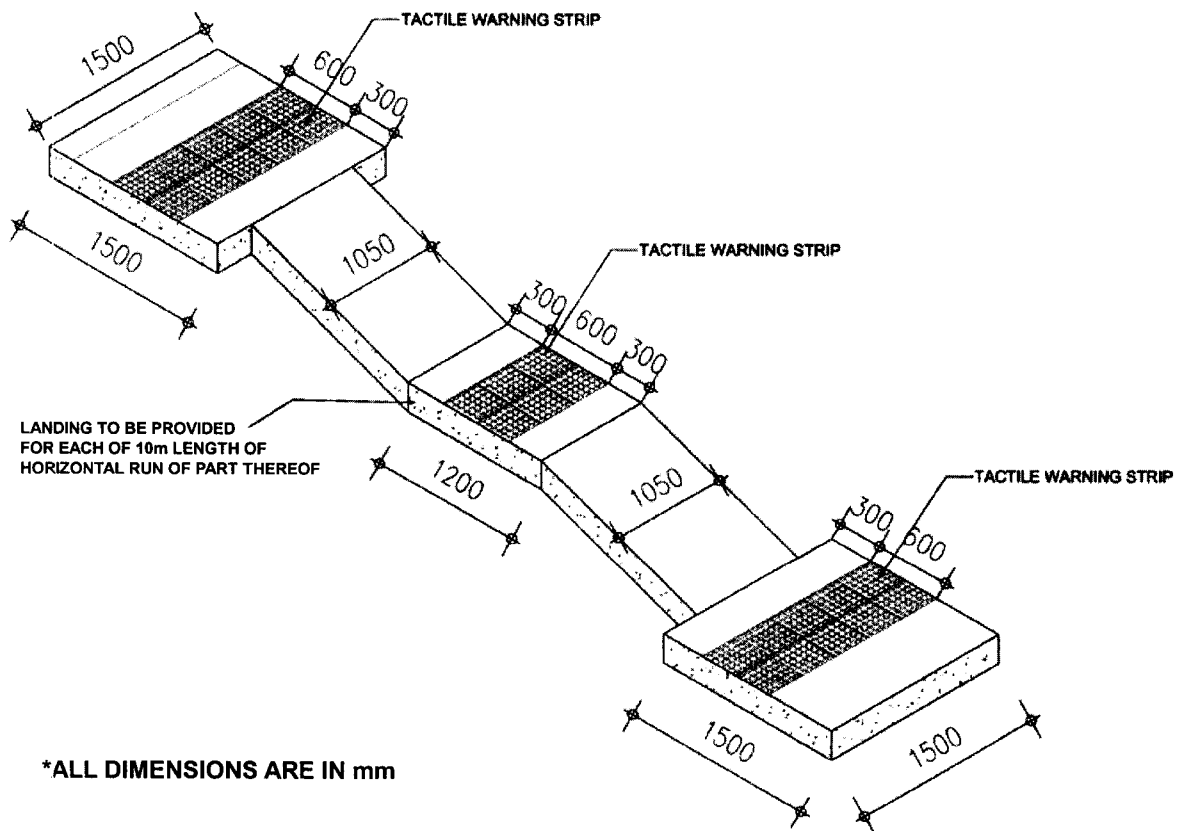

Figure 7 - Tactile Warning Strip and Landings for Ramps

BEST PRACTICE SECTION

4.2.4 Design Considerations

- (a) Where there is a change in level, the provision of a ramp is an effective method to ensure largely independent accessibility for persons with a disability and the elderly. Interior ramp is preferred as a means of egress to stair as it accommodates a wider range of building user, including wheelchair user.
- (b) The more gradual the slope of the ramp (i.e. the less steep it is) the more easily persons can use it without assistance. Therefore, slope with the ratio of 1:20 (5%) to 1:15 (6.7%) is preferred. It can take much energy to get up ramp with steep gradient, which also makes speed control difficult when going down. Steep inclines can put a wheelchair in danger of tipping backwards or forwards as many users cannot lean or adjust their balance to accommodate gradient (See **Figure 8**).
- (c) A level resting space outside the swing of any door at the top of a ramp should be provided to avoid the possibility of 'roll-back' for wheelchair user when trying to open the door.
- (d) A ramp should have handrails on both sides so that it can be used in both directions by people with a mobility problem on one side such as may be the case for stroke sufferers.
- (e) A ramp that surmounts a major change in level has to be very long, and requires multiple ramp and landing combinations. In such circumstances, other design solutions should be considered.
- (f) A curved ramp is not a preferred design solution. Similarly a cross fall can put a wheelchair user at risk and may adversely affect steering, particularly on manually propelled chair.

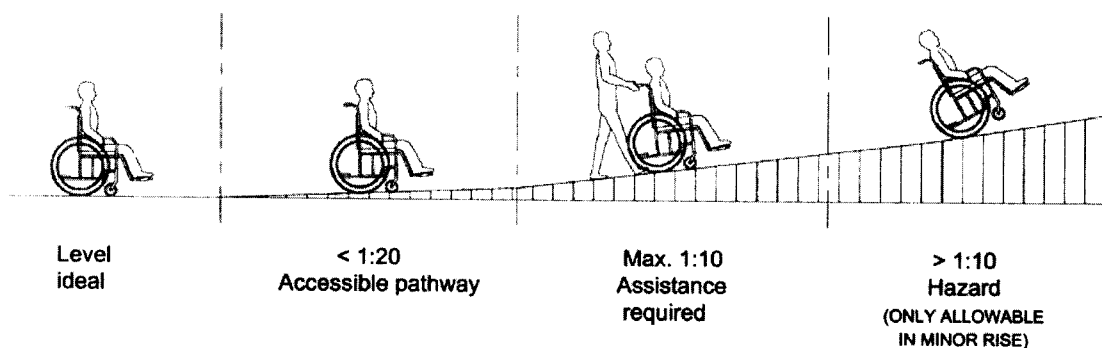

Figure 8 - Running Slope and Length

4.2.5 Recommended Design Requirements

- (a) A ramp should have a running slope 1:12 (8.33%) to 1:20 (5%).

Maximum slope	Maximum length	Maximum rise
1:20 i.e., 5.00%	10000 mm	500 mm
1:16 i.e., 6.25%	6400 mm	400 mm
1:14 i.e., 7.14%	4200 mm	300 mm
1:12 i.e., 8.33%	1800 mm	150 mm

- (b) Width should be at least 1200 mm to enable a wheelchair to turn or preferably at least 1500 mm to allow 2 wheelchairs to pass.
- (c) A ramp should have slip-resistant surface with a minimum static “coefficient of friction” of “Very Good” grading (see **Appendix C**).
- (d) Tactile warning strips at the head, foot and landing should have a minimum luminous contrast of 70% with the adjoining surfaces.
- (e) The floor and wall along a ramp should have a minimum luminous contrast of 30%.

4.3 DROPPED KERBS

4.3.1 A dropped kerb is a ramp built on a footpath or pavement to accommodate the change in level towards vehicular areas.

MANDATORY SECTION

4.3.2 Performance Objectives

Dropped kerbs shall be of appropriate design and provided with adequate visual and tactile warning.

4.3.3 Obligatory Design Requirements

Dimension and Gradient

- (a) Changes in level at kerbs shall be by a dropped kerb as illustrated in **Figure 9**. Dropped kerb shall be provided at pedestrian crossing and at each end of the footpath of a private street or access road. Kerb separating footpath or ramp from vehicular area shall also be a dropped kerb. Dropped kerb shall be constructed as follows: -
- (i) not less than 1200 mm in length and 1200 mm in width;
 - (ii) with a clearance of at least 800 mm long at the back of the footway;
 - (iii) ramped at a gradient not steeper than 1:10;
 - (iv) with a level difference of not more than 15 mm with the vehicular areas;
 - (v) provided with a tactile warning strip at 300 mm from the vehicular areas; and
 - (vi) provided with a tactile warning strip of the nominal width of 600 mm at the ramp.

4.3.3 Obligatory Design Requirements (Cont'd)

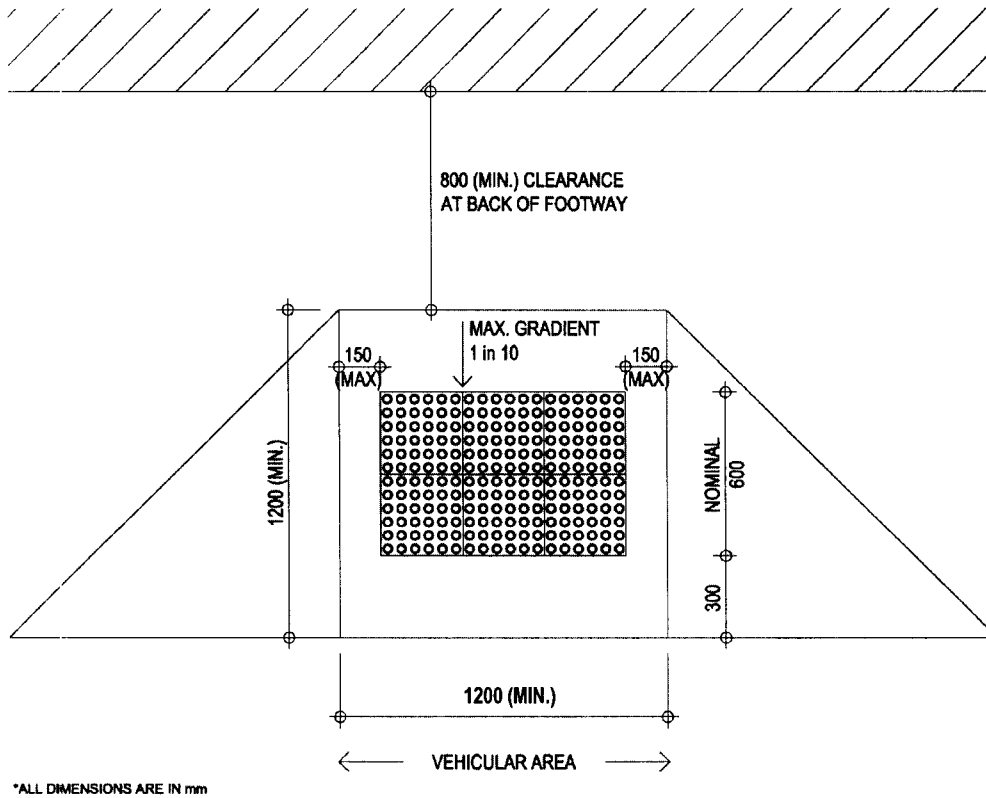

Figure 9 – Dropped Kerb

Location

- (b) Dropped kerb shall be so located to enable users to have an unobstructed view of traffic approaching from any direction.

Surface

- (c) Raised traction strips shall be avoided.

BEST PRACTICE SECTION

4.3.4 Design Considerations

- (a) The provision of a dropped kerb is to overcome potential hazard arising from change in level for persons with or without a disability.
- (b) The tactile warning strip should be provided in order to notify the presence of traffic.
- (c) The tactile warning strip should have luminous contrast for the elderly and persons with vision impairment.
- (d) Dropped kerb should have slip-resistant surface. Raised traction strips should be avoided in order to reduce the hazard to everyone.
- (e) Examples of dropped kerb are shown in **Figures 10, 11 and 12**.

4.3.5 Recommended Design Requirements

Slip Resistance

- (a) Dropped kerb should have slip-resistant surface with a minimum static “coefficient of friction” of “Very Good” grading (see **Appendix C**).

Luminous Contrast

- (b) Tactile warning strip should have a minimum luminous contrast of 70% with the adjoining surfaces.

Conjunction with Pedestrian Crossings

- (c) Dropped kerb should be provided where necessary and in conjunction with pedestrian crossings, which should include visible, audible and tactile crossing devices with traffic lights.

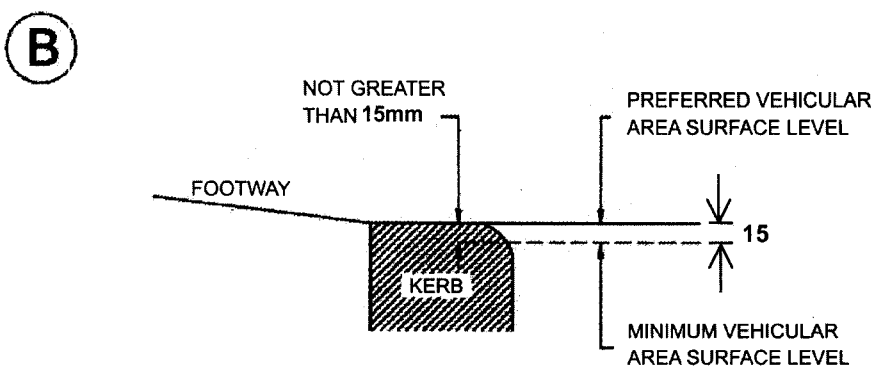
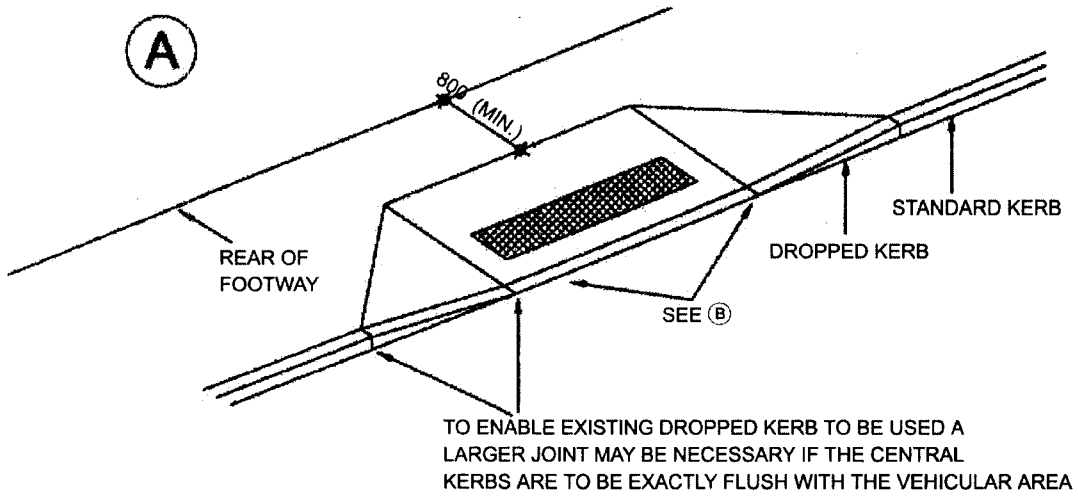

*ALL DIMENSIONS ARE IN mm

Figure 10 - Examples of Design of Dropped Kerb

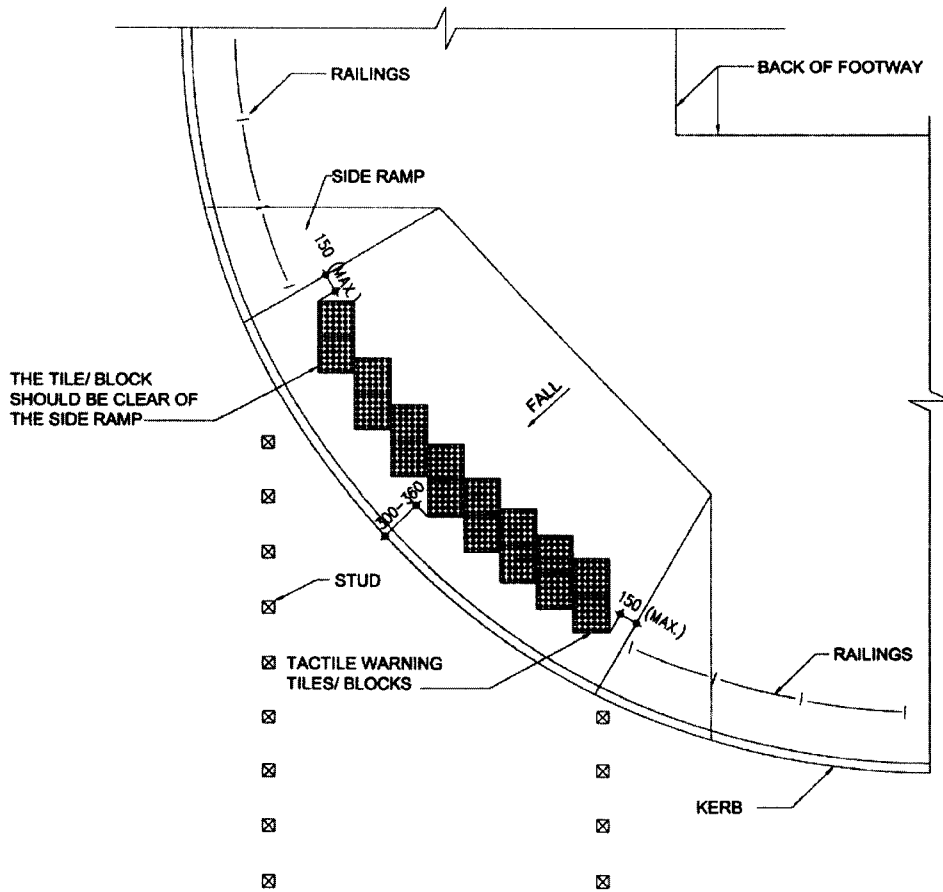

*ALL DIMENSIONS ARE IN mm

Figure 11 – Dropped Kerb at Street Corner

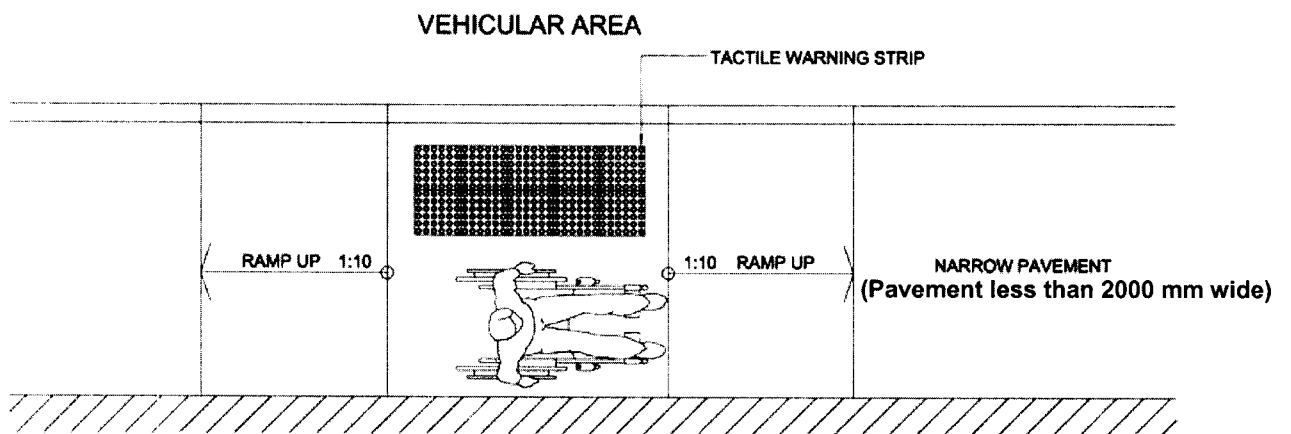

*ALL DIMENSIONS ARE IN mm

Figure 12 – Dropped Kerb for Access Road and Narrow Pavement

4.4 STEPS AND STAIRCASES

4.4.1 This section sets out requirements to help people including persons with ambulant disabilities and persons with visual impairment to negotiate steps and staircases.

MANDATORY SECTION

4.4.2 Performance Objectives

Steps and staircases shall be intended as an alternative to lift access in buildings and shall be of adequate design to allow all persons, with or without a disability, to travel safely and independently.

4.4.3 Obligatory Design Requirements

Dimension and Orientation

- (a) The required staircases and the main circulation staircase in common areas of a building shall:
- (i) be constructed with treads not less than 225 mm in width (measured at the centre of the flight) from the face of one riser to the face of the next riser and with risers not more than 175 mm in height;
 - (ii) have risers built with vertical or receding face not more than 15 mm from the vertical, without a projecting nosing;
 - (iii) have not more than 16 steps in any flight without the introduction of a landing;
 - (iv) be provided on both sides with properly fitted handrails (see **Clause 4.5.3(b)**);
 - (v) be provided with non-slip nosing in contrasting colour; and
 - (vi) have risers reduced to not more than 160 mm high and treads increased to not less than 280 mm wide for greater ease of use for external steps and stairs.

4.4.3 Obligatory Design Requirements (Cont'd)

Tactile Warning Strip

- (b) Tactile warning strips shall be provided at landings and at both the bottom and top ends of a staircase, regardless of the number of steps it comprises. For landings leading to a floor or those enclosed by wall, railing or balustrade, tactile warning strips of 300 mm in width shall be provided; for those leading to an open space or the entrance / exit of a building, the tactile warning strips shall be 600 mm in width (see **Figure 13**). In this case, Braille and tactile information signs shall be provided on the adjacent wall to indicate the presence of an opening. For a staircase with intermediate steps between two flights, the provision of tactile warning strips shall follow the arrangement in **Figure 13**.

Colour Contrast

- (c) Treads and walls of a staircase shall be in contrasting colours.

Avoidance of Projection

- (d) No appliances, fixtures and fittings shall project beyond 90 mm from the surface of any wall in a staircase below a level of 2000 mm above the treads of the staircase unless they are unavoidable, in which case they shall also be extended downwards to the level of the treads.

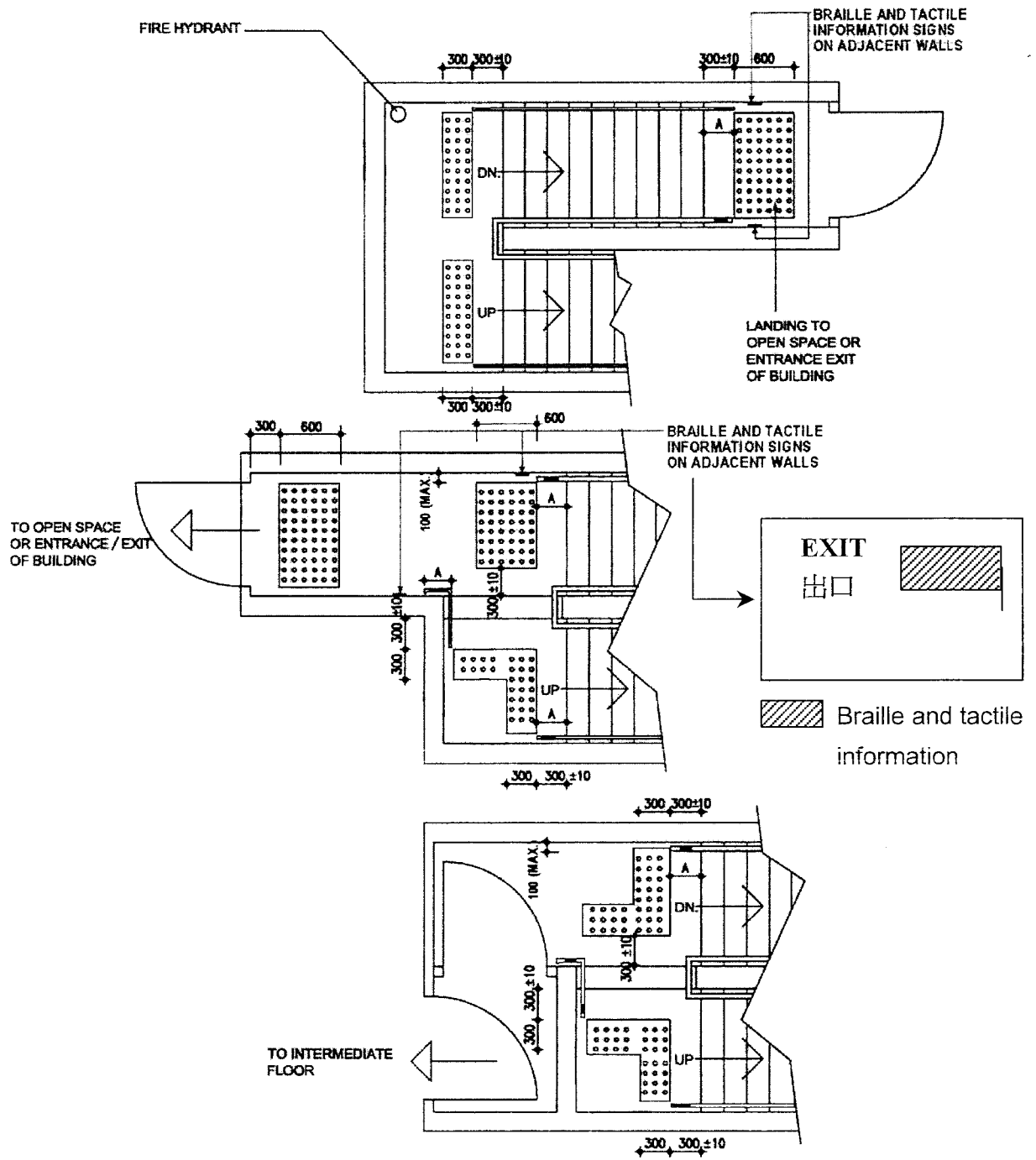

Figure 13 – Arrangement of Tactile Warning Strips and Handrails at Staircases

BEST PRACTICE SECTION

4.4.4 Design Considerations

- (a) Where steps or stairs are in an accessible route, complementary ramps, lifts or elevators should be provided.
- (b) All steps should be uniform.
- (c) Circular stair and sloped landing should be avoided.
- (d) It is necessary to provide safe and well-dimensioned staircase for the comfort of all people, especially those with mobility problems.
- (e) When ascending a stair, people who wear calipers or who have stiffness in hip or knee joints are particularly at risk of trapping the toes of their shoes beneath projecting nosings.
- (f) Stair should be designed with more generous dimensions, e.g. wider tread, and shorter travel distance is recommended. Open risers should be avoided.
- (g) Unawareness of steps is dangerous to persons with visual impairment. Timely tactile or audible warning of change in level is therefore essential. Warning should be placed sufficiently in advance of any potential dangers.
- (h) The provision of Braille and high luminous contrast signs is recommended. For persons with visual impairment, high luminous contrast, larger font, more prominent and well-defined shape of sign/signage is recommended.
- (i) Despite the design requirements of tactile guide paths and tactile warning strips would help orientation for persons with visual impairment, they sometimes impose hazards to people with limited mobility, children and the elderly.

4.4.5 Recommended Design Requirements

Dimension and Orientation

- (a) For any internal stair with heavy circulation, riser should be reduced to 150 mm high and tread be increased to 300 mm wide for greater ease of use.
- (b) Individual flight should not exceed 1800 mm in height nor a total of 12 risers.
- (c) The top nosing of any flight should be built not less than 300 mm from the point at which the adjoining wall returns (see **Figure 14**).
- (d) Winder, spiral staircase and splayed step should be avoided.

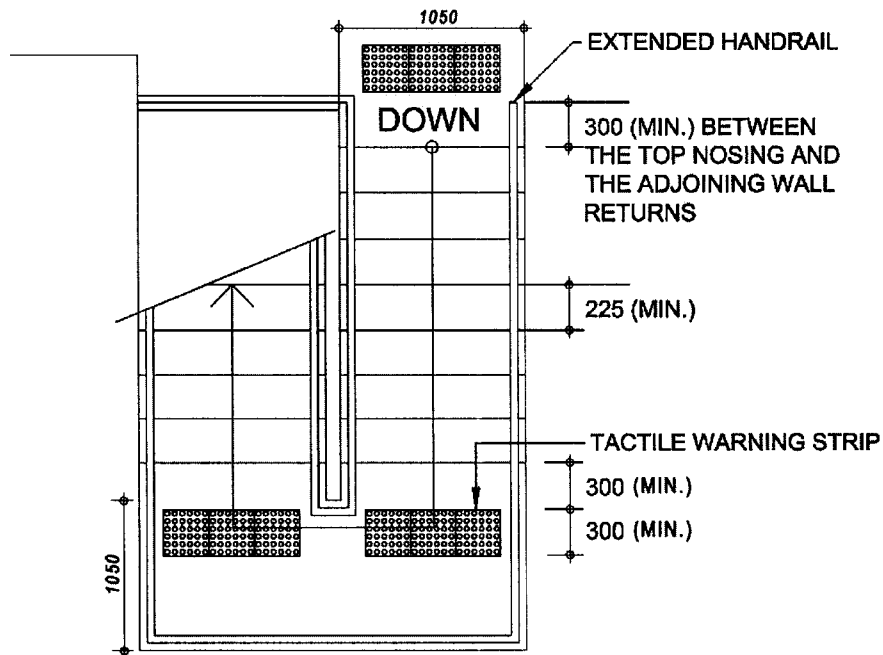

*ALL DIMENSIONS ARE IN mm

Figure 14 – Example of Staircase Plan for Persons with a Disability

Luminous Contrast

- (e) Non-slip nosing should have a minimum luminous contrast of 30% with the adjoining surfaces.
- (f) Treads of staircase should have a minimum luminous contrast of 30% with the walls.

4.5 HANDRAILS

- 4.5.1 Handrails provide support for everyone and are especially helpful for persons with a disability and the elderly to use staircases, to pull themselves up inclines, check themselves on declines and to assist them in moving within the building.

MANDATORY SECTION

4.5.2 Performance Objectives

Handrails shall be of the correct sizes, strengths and shapes and be conveniently located to provide secure hand-grips, and be capable of taking the entire weight of the persons using them.

4.5.3 Obligatory Design Requirements

Dimension

- (a) Handrail to ramp and step shall be fixed not less than 30 mm and not more than 50 mm clear of wall and with a clear height of 70 mm from the top of the bracket to the top of the handrail.
- (b) The top of handrail shall be at a height of not less than 850 mm and not more than 950 mm above any nosing, floor or landing.
- (c) Handrail shall extend horizontally not less than 300 mm beyond the first and last nosing of every flight of steps or beyond the ends of a ramp and terminate into a closed end which shall turn down or return fully to end post or wall face and which shall not project into a route of travel. Where a door opening is in place, a shortened extension of not less than 100 mm shall be permitted.

Loading

- (d) Handrail shall be installed to resist a load of not less than 1.3 kN applied vertically or horizontally.
- (e) Handrail shall not rotate within their fixing fittings.

Diameter

- (f) Handrail shall be:
 - (i) tubular, not less than 32 mm and not greater than 50 mm in external diameter; or
 - (ii) in other shapes that can provide the user a grip analogous to that specified in the case of tubular handrails.

Typical handrail sections are shown in **Figure 15**.

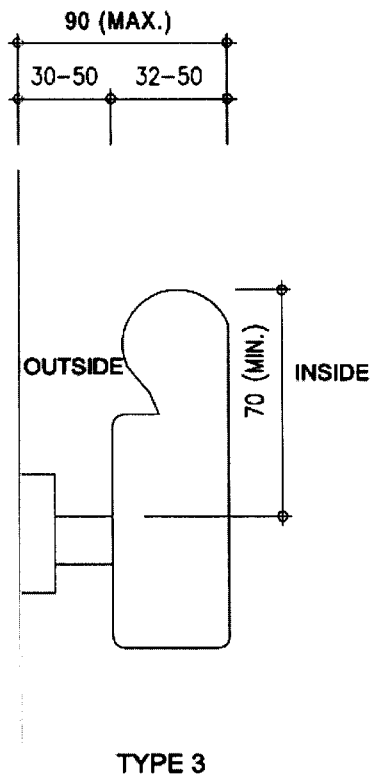
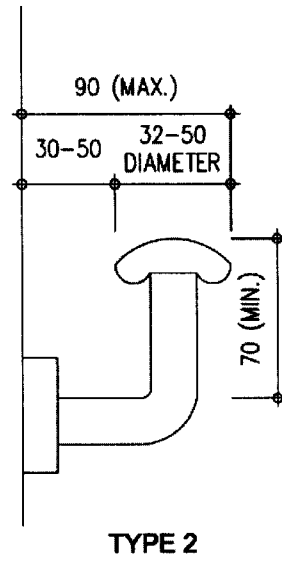
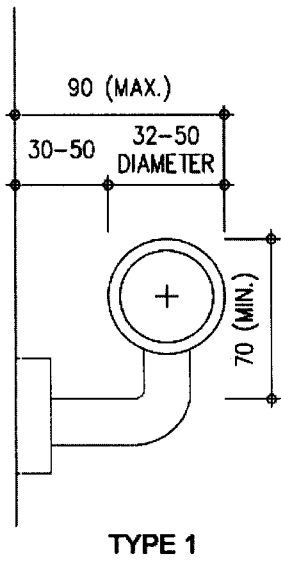

***ALL DIMENSIONS ARE IN mm**

Figure 15 - Handrails

4.5.3 Obligatory Design Requirements (Cont'd)

Braille and Tactile

- (g) Braille and tactile information on directional arrow and floor number shall be provided on handrail on every floor at a designated location as illustrated in **Figures 16A** to facilitate persons with visual impairment. Where a directional sign exists, Braille and tactile information shall also be provided as illustrated in **Figure 13**.

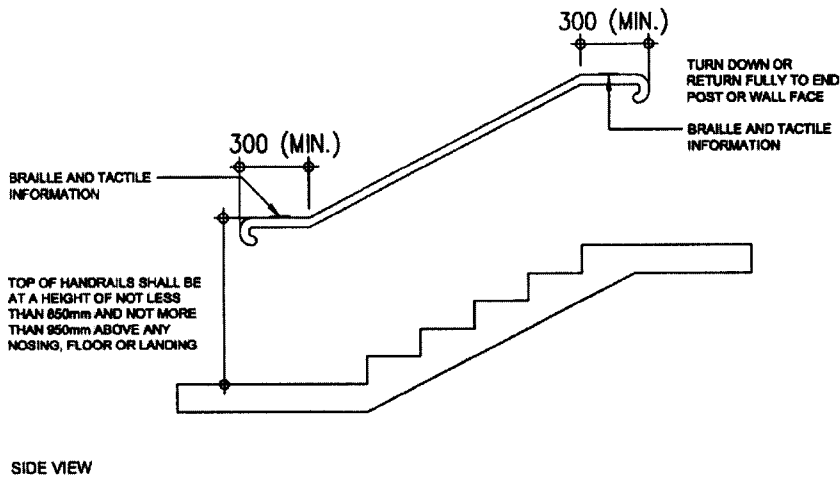

Other alternatives of end of handrail

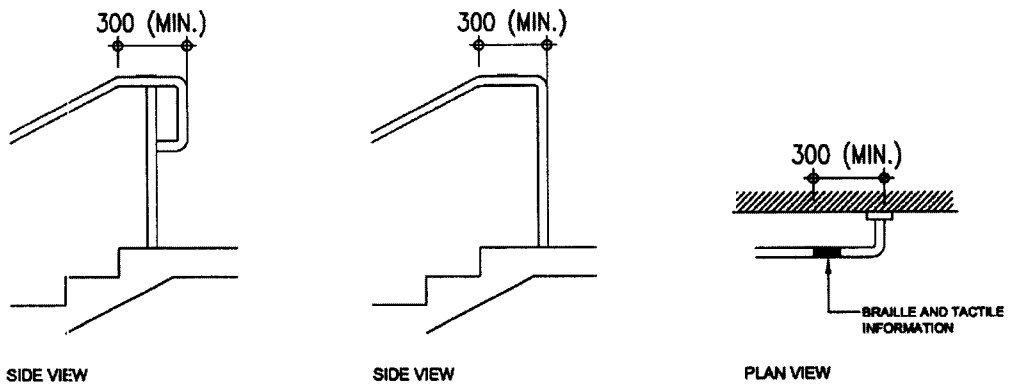

Braille Characters



UP



DOWN

*ALL DIMENSIONS ARE IN mm

Figure 16A – Handrails of Staircase

BEST PRACTICE SECTION

4.5.4 Design Considerations

- (a) Handrail should be designed to provide easy, firm and comfortable grip to all users and should have no obstruction when people slide their hands along the handrail.
- (b) The installation level of the handrail and clearance dimensions should facilitate a safer grip and prevent hand injuries especially for the elderly and persons with visual impairment.
- (c) Handrail finished in more noticeable colours with Braille and tactile information should facilitate self-help circulation of persons with visual impairment.
- (d) The materials and shapes of handrail should be carefully designed to suit the elderly. In addition, handrail designed with different levels of grab bars should be recommended for different users' purposes.
- (e) Handrail should be set at height that is convenient for all users of the building and should extend safely beyond the top and bottom of a flight of steps, or a ramp, to give both stability and warning of the presence of a change in level.

4.5.5 Recommended Design Requirements

Clear Space

- (a) Where the wall has a rough surface, the clear space should be not less than 45 mm between the handrail and the wall.
- (b) A recess containing a handrail should extend not less than 450 mm above the top of the handrail as illustrated in **Figure 16B**.

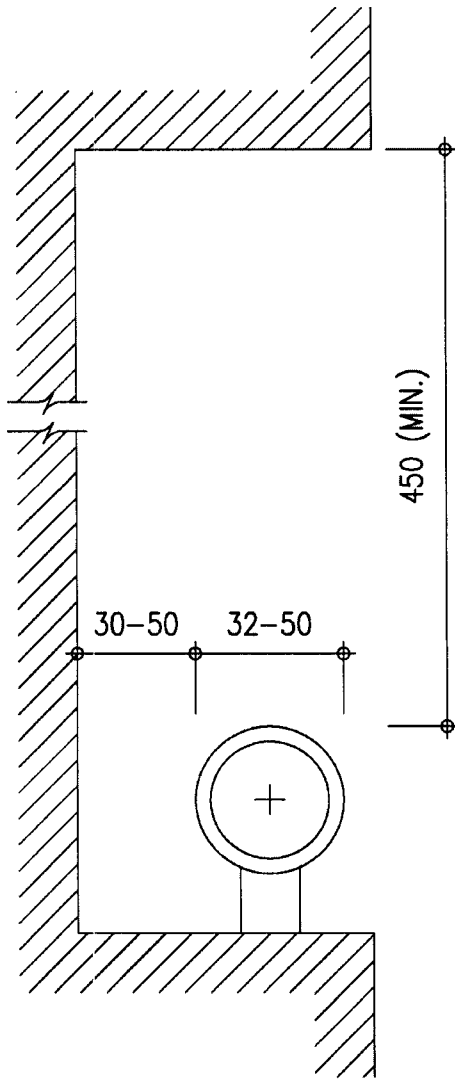

*ALL DIMENSIONS ARE IN mm

Figure 16B –Handrail in Recess

Double Handrail

- (c) One more handrail should be provided at a height of not less than 700 mm and not more than 800 mm above any nosing, floor or landing for schools and places of public entertainment.

Luminous Contrast

- (d) Handrail should have a minimum luminous contrast of 30% with the surrounding wall surfaces.

4.6 CORRIDORS, LOBBIES AND PATHS

4.6.1 Corridors are passages providing for internal circulation within a building. Lobbies provide interceptions at entries to staircases or lifts and connections to corridors where appropriate.

MANDATORY SECTION

4.6.2 Performance Objectives

Corridors, lobbies and paths shall be designed to an appropriate standard to allow all people to travel within a building safely and independently.

4.6.3 Obligatory Design Requirements

Manoeuvring Space

- (a) Space shall be allowed for manoeuvring wheelchairs in corridor, lobby, path and similar areas as follows:
 - (i) area shall have a clear width of not less than 1050 mm;
 - (ii) a space not less than 1500 mm x 1500 mm shall be provided within 3500 mm of every dead end;
 - (iii) any lobby in a corridor shall have a length of not less than 1200 mm, excluding space for door swings; and
 - (iv) a level area, extending not less than 1200 mm beyond the swings of the doors and not less than 1500 mm in width shall be provided on both sides of every entrance of a building.

The above items shall not apply to lobby which lead to staircase only.

For the purpose of this section, "dead end" is a corridor, lobby or path where the means of exit for persons with a disability is in one direction only.

Channel Covers

- (b) On footpath, cover to a channel shall be flush with the surface of the footpath. Any hole in such cover or between such covers shall have a dimension of not more than 20 mm.

Gratings

- (c) Slot of gratings shall have a width of not more than 13 mm and shall not be parallel with pedestrian travel path (see **Figure 17**).

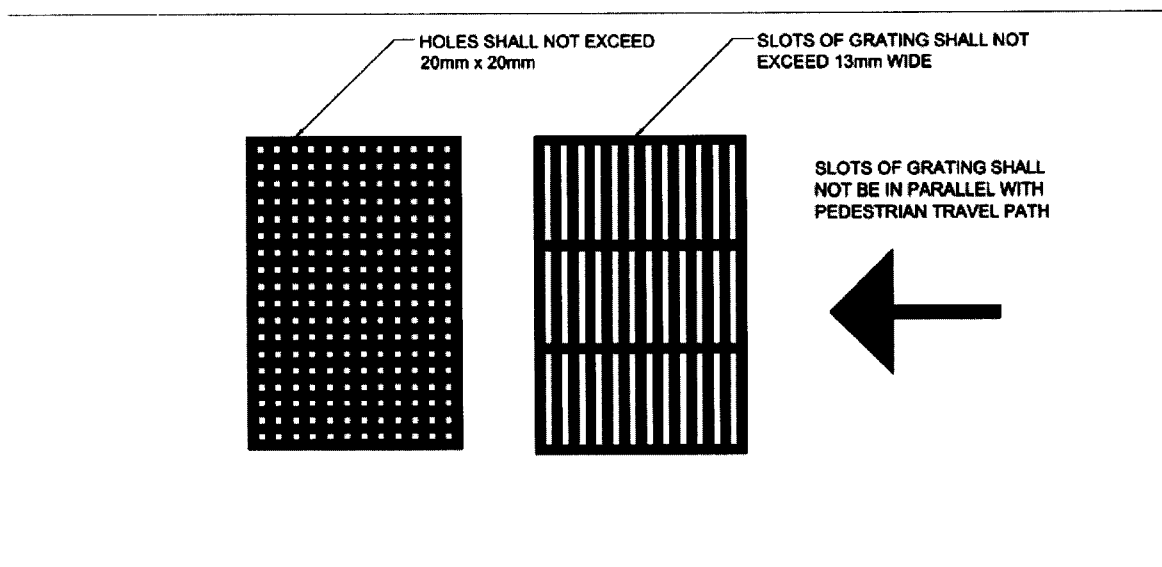

Figure 17 – Grating Size and Orientation

4.6.3 Obligatory Design Requirements (Cont'd)

Protrusion

- (d) No appliances, fixtures and fittings shall project beyond 90 mm from the surface of any wall in corridors, paths and lobbies below a level of 2000 mm above the finished floor level unless they are unavoidable, in which case they shall also be extended downwards to the finished floor level or guided by tactile flooring materials.

Width of Controlled Passages

- (e) For cashier counter, security device installed at shop entrance and turnstile controlled passage accessible to the public, each shall have at least one path of minimum 800 mm in width for the use by wheelchair users and clearly marked with international symbol of accessibility, unless an alternative passage adjacent to the controlled passage is provided. (See **Figure 18** for examples)

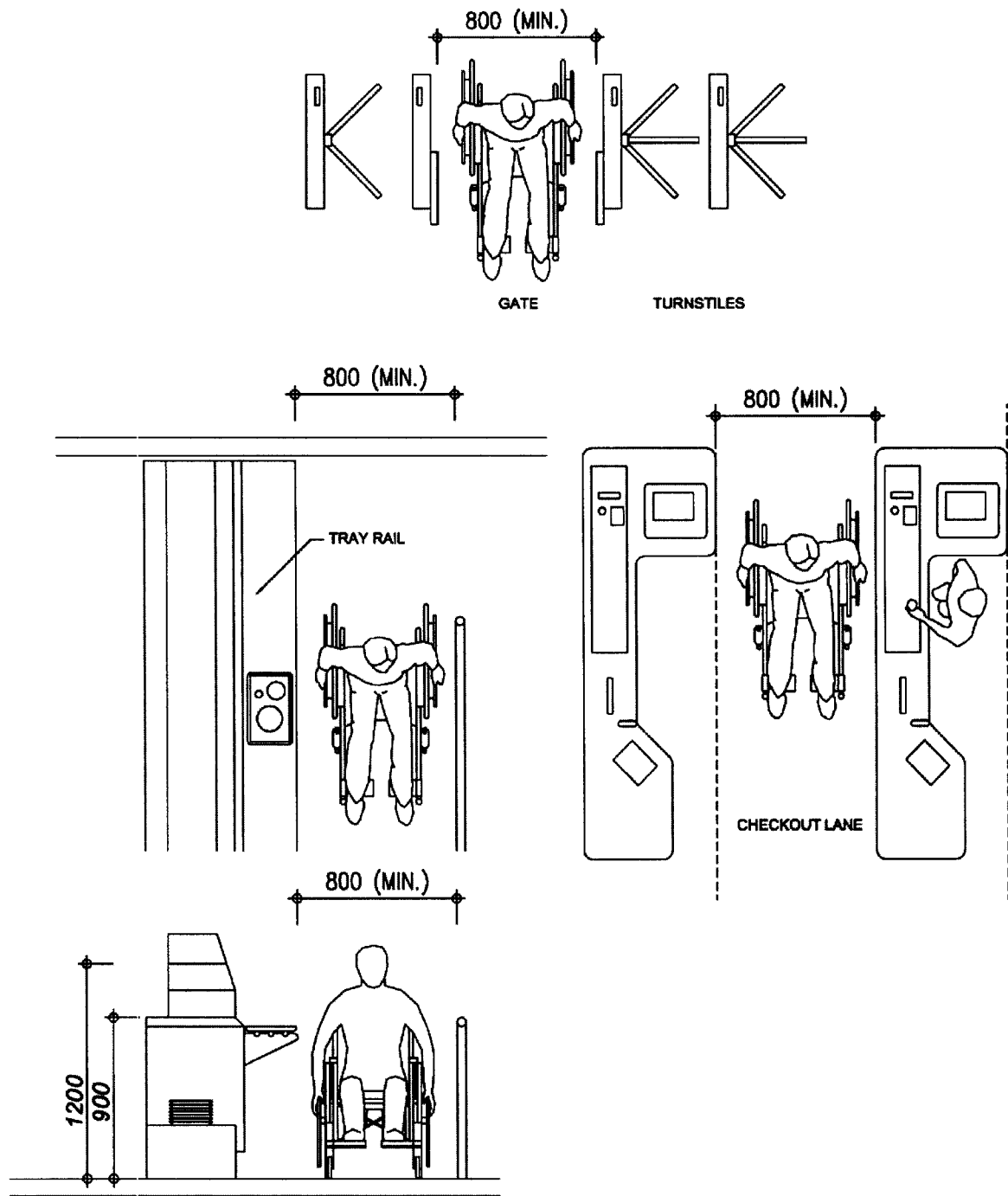

*ALL DIMENSIONS ARE IN mm

Figure 18 – Width of Controlled Passages

4.6.3 Obligatory Design Requirements (Cont'd)

Headroom

- (f) Where the headroom is 2000 mm or less from the finished floor level, a warning guardrail or other barrier shall be provided for detection, having its leading edge at or below 680 mm above the finished floor level (see **Figure 19**).

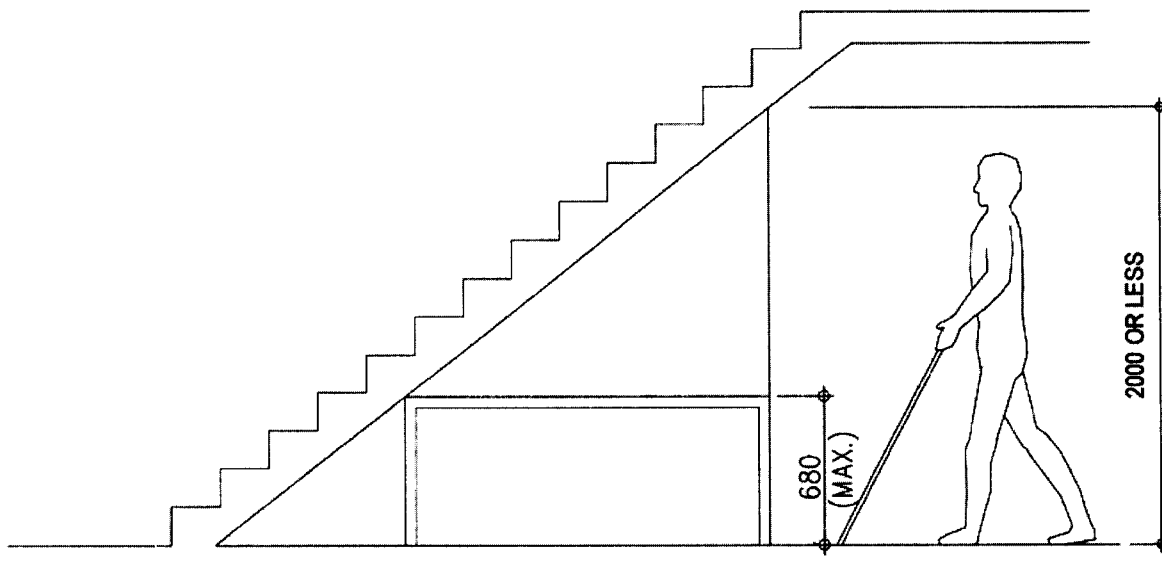

*ALL DIMENSIONS ARE IN mm

Figure 19 – Overhead Hazard

BEST PRACTICE SECTION

4.6.4 Design Considerations

- (a) Corridors, lobbies and paths should be designed to have appropriate dimensions to allow people using wheelchair or other forms of mobility aids to pass others on the access route.
- (b) To facilitate the way finding for persons with visual impairment, surfaces and finishes with luminous contrast between the wall and the ceiling, and between the wall and the floor should be adopted. Appropriate lighting design with adequate illumination should also be considered.
- (c) Adequate manoeuvring space for wheelchair particularly in lobby and corridor of domestic building should be provided in order to facilitate the wheelchair users in passing through corridor especially when turning through 180° is required.
- (d) Protruding object can be extremely hazardous to the persons with visual impairment as well as the general public. Examples of protruding obstruction are sign, drinking fountain, fire extinguisher, telephone enclosure, and underside of stairway or escalator, etc. Protruding object should be recessed into the wall as far as possible.

4.6.5 Recommended Design Requirements

Width (See Figure 20)

- (a) Path width should be more than 1200 mm to enable a wheelchair user to pass anyone who is on the same path or preferably at least 1500 mm to allow two wheelchairs to pass. At right angle turns, inside corner should be splayed or rounded to at least 300 mm radius.

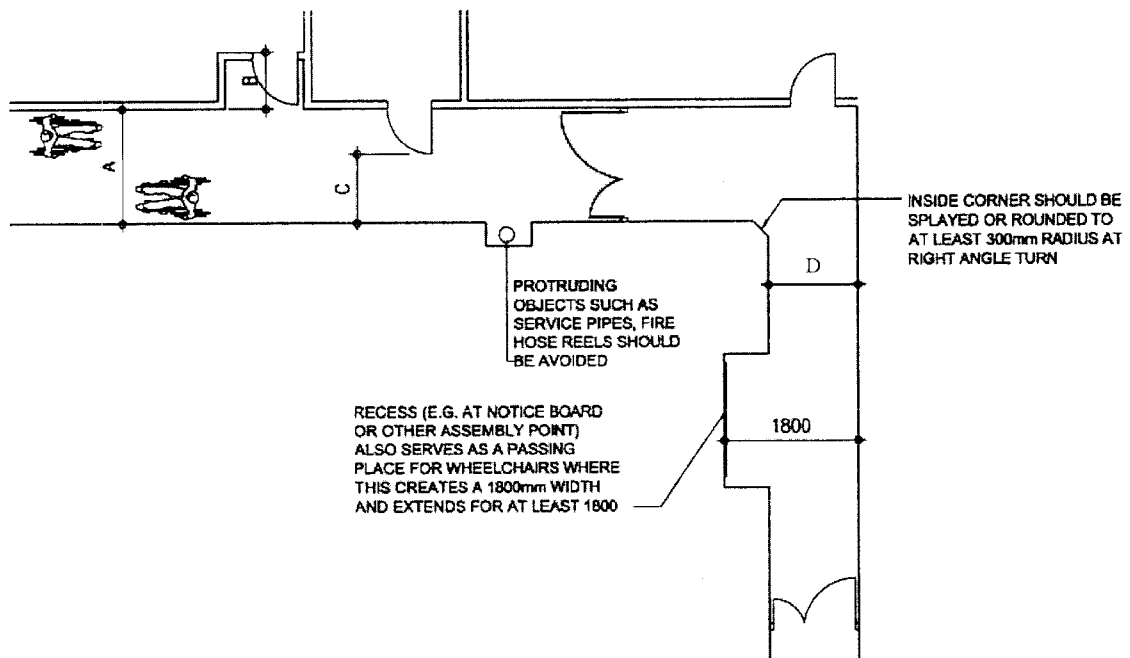

- A. A CLEAR WIDTH OF 1500mm WILL ALLOW TWO WHEELCHAIR USERS TO PASS EACH OTHER.
- B. DEPTH OF RECESS SHOULD NOT BE LESS THAN THE WIDTH OF THE DOOR LEAF.
- C. 900mm CLEAR SPACE WHERE DOORS OPEN INTO A CORRIDOR.
- D. A CLEAR WIDTH OF CORRIDOR SHOULD NOT BE LESS THAN 1200mm

*ALL DIMENSIONS ARE IN mm

Figure 20 – Dimension and Space Allowance for Corridor in Building

4.6.5 Recommended Design Requirements (Cont'd)

Surface

- (b) All corridors should have slip-resistant surfaces with a static coefficient of friction of "Good" grading (see **Appendix C**).
- (c) Surface paved with loose gravel or stone is hazardous and should be avoided.
- (d) Hazards on floor, caused by unnecessary projection or by unexpected change in level should be avoided.

Luminous Contrast

- (e) A minimum luminous contrast of 30% should clearly define between wall, floor and door surfaces

Protruding Objects (See Figure 21)

- (f) The protruding object should not reduce the statutory required clear width and height of access and manoeuvring space.
- (g) Protruding object should include but not limited to sign, telephone enclosure, drinking fountain, fire extinguisher, underside of stairway or escalator.
- (h) Where it is reasonable to anticipate visit of persons with visual impairment, protruding object should be avoided at pedestrian areas include walkway, hall, corridor, aisle, lobby, mall and all areas open to the public.

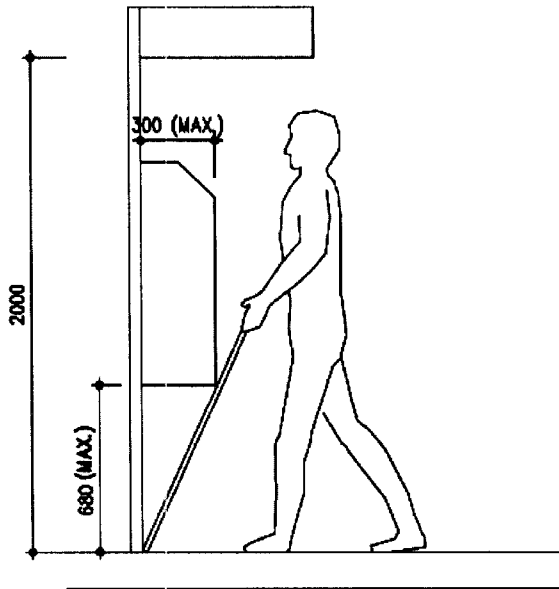
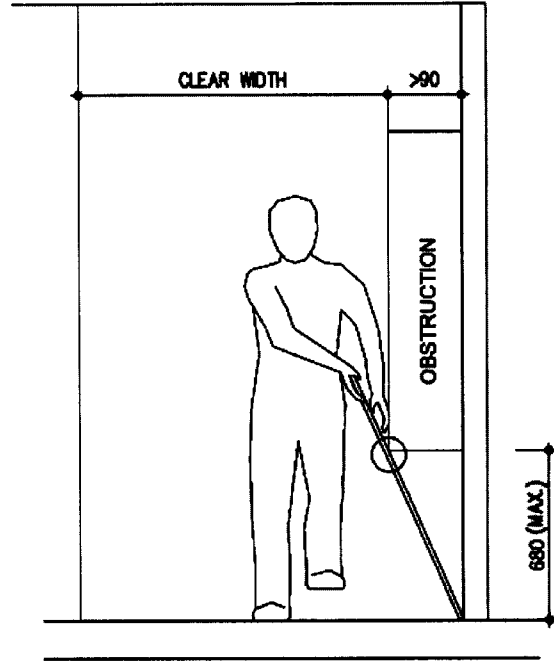
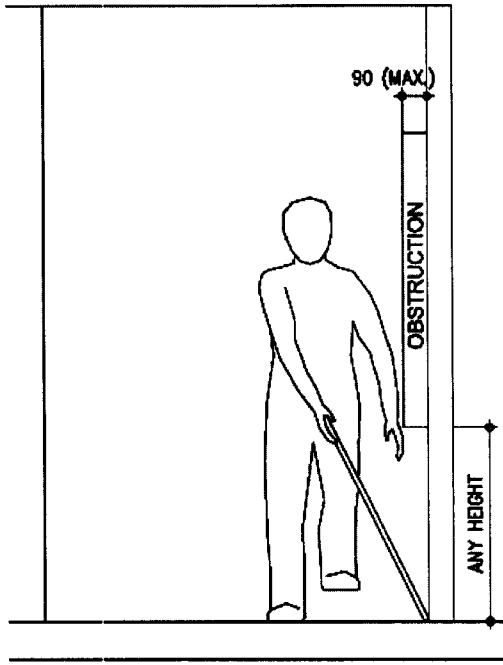

*ALL DIMENSIONS ARE IN mm

Figure 21 – Examples of Design to Cater for Protrusion Hazards

4.7 DOORS

4.7.1 The requirements of this section apply to doors on accessible routes.

MANDATORY SECTION

4.7.2 Performance Objectives

Doors and doorways shall be designed to enable all people especially wheelchair user to enter and leave any room unaided and without undue difficulties.

4.7.3 Obligatory Design Requirements

Width (see Figure 22)

- (a) Door, including one leaf of a pair of double doors, shall have a clear width of not less than 800 mm between the open door and opposite jamb or the other leaf.

Unobstructed Area (see Figure 22)

- (b) The unobstructed area adjacent to the door handle on the leading face of a single door shall not be less than 330 mm in width.
- (c) Door, if less than 330 mm from the corner of a room, shall swing from the side nearer to that corner.

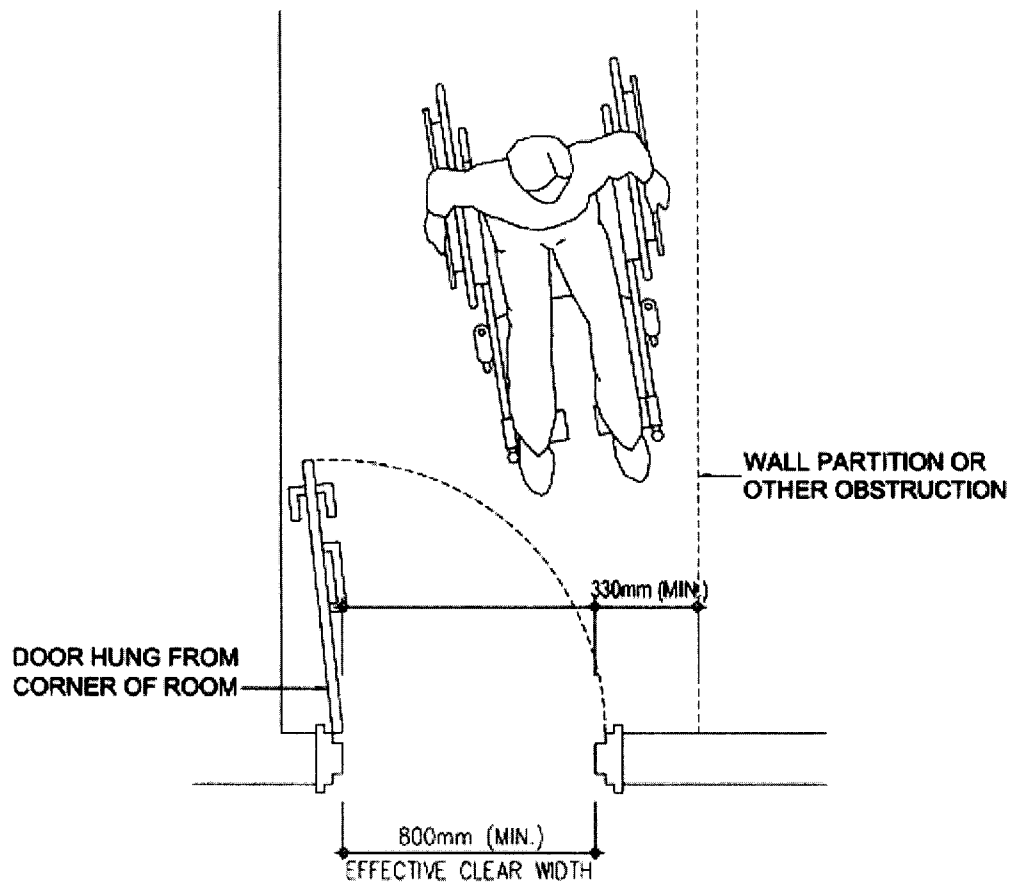

*ALL DIMENSIONS ARE IN mm

Figure 22 – Plan of Door Suitable for Wheelchair

4.7.3 Obligatory Design Requirements (Cont'd)

Double-action Self-closing Doors

- (d) Double-action self-closing door shall have a check mechanism to prevent the door swinging beyond the closed position and a transparent vision-panel with a bottom edge not more than 1000 mm above the floor and the top edge not less than 1500 mm above the finished floor level.

Handles

- (e) Door handle shall not be less than 950 mm and not more than 1050 mm above the finished floor level, measured from the top surface of the grip.

4.7.3 Obligatory Design Requirements (Cont'd)

Thresholds

- (f) Door threshold shall not exceed 20 mm in height and shall be bevelled to facilitate passage of wheelchairs.

Closing Devices

- (g) Door closing devices shall be designed to allow exterior and interior doors to be opened with horizontal force of not more than 30 N and 22 N respectively. Door required to have fire resistance period installed along accessible routes shall be opened with horizontal force of not more than 30 N. Closer for interior door shall have a closing period of at least 3 seconds measured from an open position of 70° to a point 75 mm from the closed position measured from the leading edge of the door. Door closing devices include door closer, spring hinge and floor hinge.

Frameless Glass Doors

- (h) If frameless glass door is used, it shall be prominently marked so as to make it visible. The marking shall be placed across on the glass door such that at least a portion of the marking is placed between 900 mm and 1500 mm above the finished floor. The colour marking shall also be provided to glass panel adjacent to the glass door.

Automatic Main Entrance Doors

- (i) Automatic door shall be provided to one of the main entrances, which is commonly used by the public, of stadium, town hall, civic centre, theatre, museum, public library, sports complex, public swimming pool complex, hotel, shopping complex, hospital and office building.

BEST PRACTICE SECTION

4.7.4 Design Considerations

- (a) Door may be manually operated without powered assistance, or power operated under manual or automatic control. An automatically operated sliding door is a preferred solution for most people as it avoids the risks associated with automatic swing door and its use can make it possible to reduce the length of entrance lobbies.
- (b) A door fitted with a self-closing device to stand against wind force is difficult to be openable by many people, particularly those who are wheelchair users or who have limited strength. Where closing devices are needed for fire control, the use of electrically powered hold open devices or swing-free closing devices is appropriate.
- (c) All doors should be wide enough to allow unrestricted passage for different users, including wheelchair users, people carrying luggage and parents with baby carriages and small children.

4.7.4 Design Considerations (Cont'd)

- (d) Sufficient space alongside the leading edge of a door should be provided to enable a wheelchair user to reach and grip the door handle, then open the door without releasing hold on the handle and without the wheelchair footrest colliding with the return wall.
- (e) The presence of door, whether opened or closed, should be apparent to persons with visual impairment through the careful choice of colour and materials for the door and its surroundings. Provision of marking on glass doors would help persons with visual impairment to distinguish obstacles and passage as well as for public to avoid collision.

4.7.5 Recommended Design Requirements

External Doors

- (a) External door should be single-action and open outwards to obviate high tension in spring closers in sustaining wind pressure.

Latched Doors

- (b) Where door is latched, lever-type handle should be used.

Kickplates

- (c) All doors which allow the passage of wheelchairs should have kick-plates of not less than 200 mm high fitted on the face which swings away.

Automatic Door Openers

- (d) Automatic door opener should be provided on the main entrance door of buildings not included in **Clause 4.7.3(i)** and should:-
 - (i) remain open for a minimum of 5 seconds;
 - (ii) has a guardrail where it opens into a route of travel (see **Figure 23**);
 - (iii) has a sign showing automatic door; and
 - (iv) be located outside of the door swing.

Sliding automatic door with overhead sensor operating device or manual large button control should be provided.

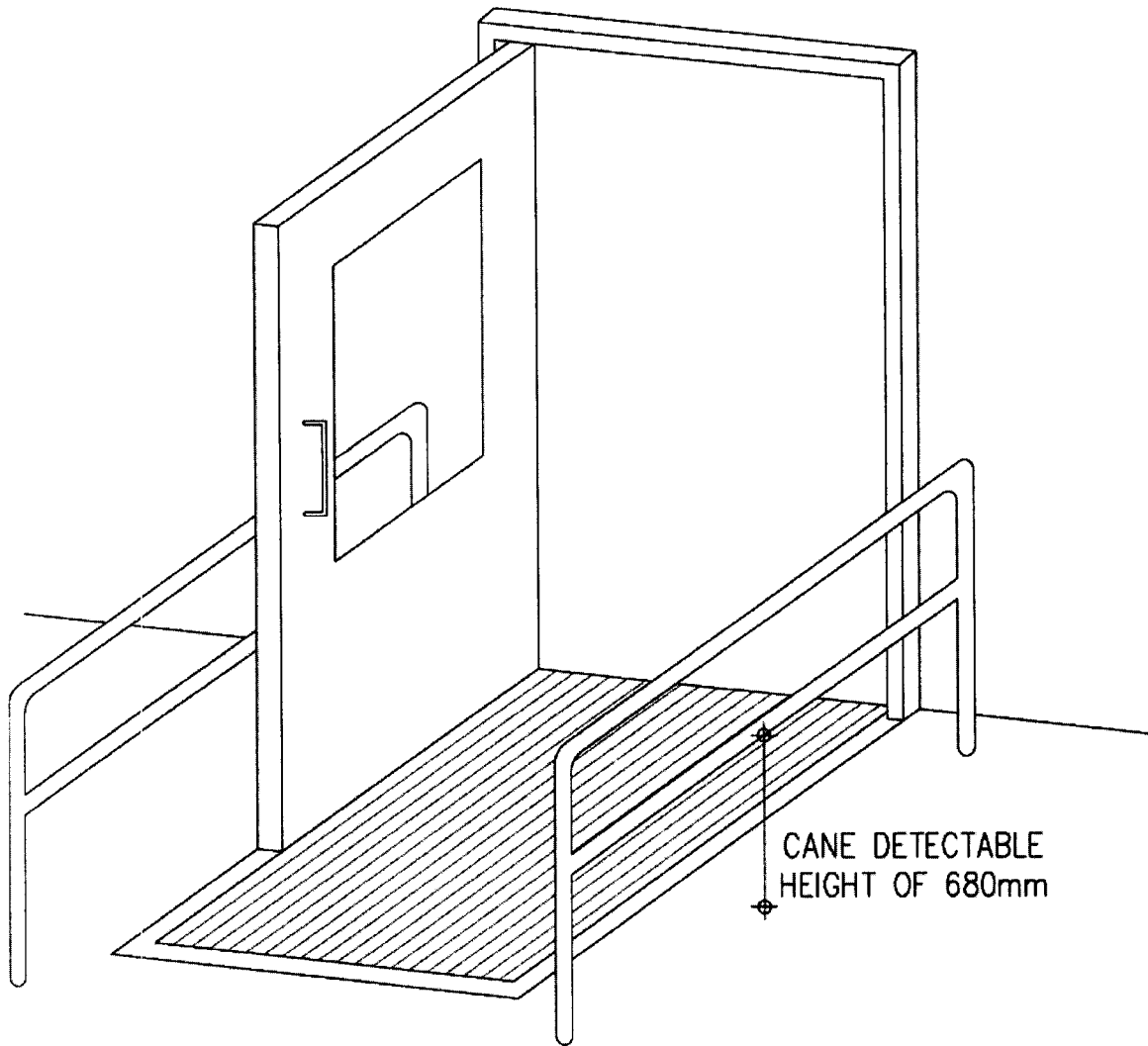

*ALL DIMENSIONS ARE IN mm

Figure 23 – Guardrails at Out-swinging Automatic Doors

Vision Panels

- (e) Transparent vision-panel should be provided to door in between accessible path. The vision-panel should be installed with bottom edge not more than 1000 mm and top edge not less than 1500 mm above the finished floor level.

Glass Doors

- (f) The leading edge of glass door should be marked to indicate glass.

Luminous Contrast

- (g) Door handle of manually operated doors and control switch or button of door with powered open devices should be contrast visually with the background against which it is seen, have a minimum luminous contrast of 30% with the background finishes.

4.8 TOILETS AND W.C. CUBICLES

- 4.8.1** This section explains the requirements to enable persons with a disability, including wheelchair users to use the facilities provided in a toilet independently as far as possible. A typical toilet is shown in **Figure 24**. Different approaches for transferring the person from a wheelchair to a watercloset are shown in **Figures B5, B6 and B7**.

MANDATORY SECTION

4.8.2 Performance Objectives

Sufficient, properly designed and located toilet and W.C. cubicles shall be available for use by everybody including people of either sex, people with babies and small children, persons with a disability, wheelchair users and the elderly and elderly with frailty, etc. with or without any assistance from others. Space requirements are set to enable a wheelchair user to manoeuvre into position for frontal, side or diagonal transfer to and from the W.C. seat.

4.8.3 Obligatory Design Requirements

Number of Accessible Toilet

- (a) There shall be at least one accessible W.C. cubicle on a floor, or in that part of a floor designed for access by the persons with a disability where the total number of W.C. cubicles provided on that floor or in that part of a floor is 20 or less, or 2 where the total number exceeds 20. This sub-section shall not apply to domestic buildings and the domestic parts of composite buildings and where there is no toilet provided on the particular floor.
- (b) Where the accessible W.C. cubicles are within a toilet with multiple cubicles, the minimum number of such accessible W.C. cubicles to be provided for each sex shall be based on the total number of W.C. cubicles for each sex on that floor or in that part of a floor designed for access by persons with a disability.
- (c) The W.C. cubicles required by this Manual shall be deemed to be included in the number of soil fitments required under the Building (Standards of Sanitary Fitments, Plumbing, Drainage Works and Latrines) Regulations (Cap. 123 sub. leg.) and Part VII of the Education Regulations (Cap. 279 sub. leg.)

4.8.3 Obligatory Design Requirements (Cont'd)

Accessible Unisex Toilet

- (d) Where toilet is provided on a floor, at least one shall be designed as an accessible unisex sanitary facility for use by both sexes and access to which does not necessitate traversing an area reserved for one sex only. It shall be designed for general use and include adequate circulation space for wheelchair users in accordance with the obligatory requirements as set out in this section.

Location of W.C. Cubicle

- (e) W.C. cubicles shall be accessible –
 - (i) directly from a public corridor which complies with **Section 4.6**; and
 - (ii) where situated within a toilet containing other W.C. cubicles, through a clear space not less than 1500 mm x 1500 mm immediately in front of the compartment to allow manoeuvrability or by direct approach where no turning of the wheelchair is necessary.

Design of Toilet and W.C. Cubicle

- (f) The accessible W.C. cubicle shall not be less than 1500 mm x 1750 mm in area and the clear manoeuvring space within the cubicle shall not be less than 1500 mm x 1500 mm measured at 350 mm above finished floor level and
 - (i) the cubicle shall have in it a watercloset at a height not less than 380 mm and not more than 450 mm, measured to the top of the toilet seat. Waterclosets shall be equipped with a back support such as a seat lid and seats shall not be spring-actuated;
 - (ii) flushing control shall be mounted on the wide side of the cubicle at a height between 600 mm to 1050 mm above the finished floor level and shall be hand-operated or automatic. Hand-operated controls shall be capable of being operated with one hand and shall not require tight grasping, pinching or twisting of the wrist. The force required shall not be greater than 22 N;
 - (iii) the toilet shall be provided with a wash basin mounted with the rim not higher than 750 mm above the finished floor level. A clearance of 550 mm shall be maintained from the finished floor level to the bottom of the apron; and
 - (iv) tap for wash basin shall be automatic or of lever control type without spring loading, subject to the approval of the Water Supplies Department. Tap shall not require tight grasping, pinching or twisting of the wrist. The operating force required shall not be greater than 22 N.

4.8.3 Obligatory Design Requirements (Cont'd)

Design of Toilet and W.C. Cubicle (Cont'd)

- (g) No coin box shall be affixed to the door of the cubicle.

Toilet / Cubicle Doors

- (h) Door shall be installed with push-type or lever-type handles and capable of being easily opened/closed by one hand. Any door fastening shall be capable of being released from the outside in the event of an emergency.

Grab Rails

- (i) There shall be at least two grab rails which shall not be less than 32 mm and not more than 40 mm in external diameter and shall be fixed on the wall leaving a grip space of not less than 30 mm clear of the mounting wall. The two grab rails constructed in one continuous piece is acceptable. The length of grab rail shall not be less than 600 mm.
- (j) There shall be one grab rail fixed on each of both the inner and outer surfaces of the cubicle door; which shall not be less than 32 mm and not more than 40 mm in external diameter. The grab rail shall have a grip space of not less than 30 mm clear of each door surface.
- (k) There shall be one folding grab rail on the wide side of the cubicle adjacent to the watercloset at a height between 725mm to 750mm above the finished floor level when lowered from the wall. Simple instructions in English, Chinese and Braille on how to unfold the rail should be affixed to the wall. The grab rail, folding grab rail and wash basin shall be capable of carrying a static load of 150 kg.
- (l) The grab rail shall not rotate within its fixing fittings.

Emergency Call Bell

- (m) An emergency call bell complying with **Section 5.4** shall be provided in the cubicle.

4.8.3 Obligatory Design Requirements (Cont'd)

Urinals (see Figure 25)

- (n) If more than one urinal is provided, at least one urinal shall
 - (i) have a clear levelled space of not less than 800 mm wide x 1500 mm deep in front; and
 - (ii) be wall hung urinal with a front rim not higher than 400 mm, and have vertical grab rails of not less than 32 mm and not more than 40mm in external diameter and of 600 mm length on both sides at a height of 1200 mm above the finished floor level for use by persons with ambulant disabilities.

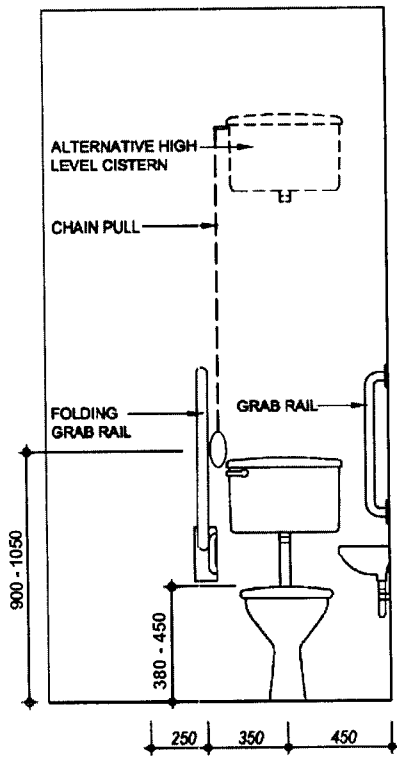

FRONT ELEVATION

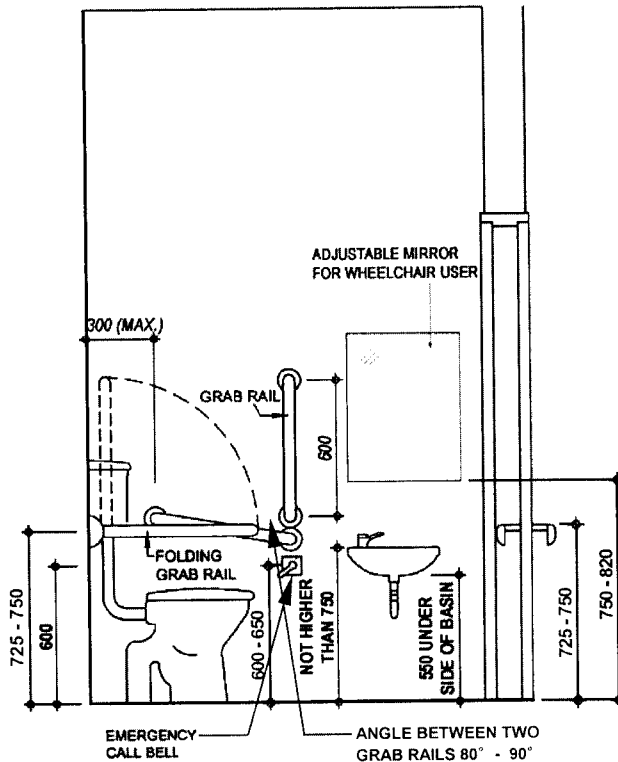

SIDE ELEVATION

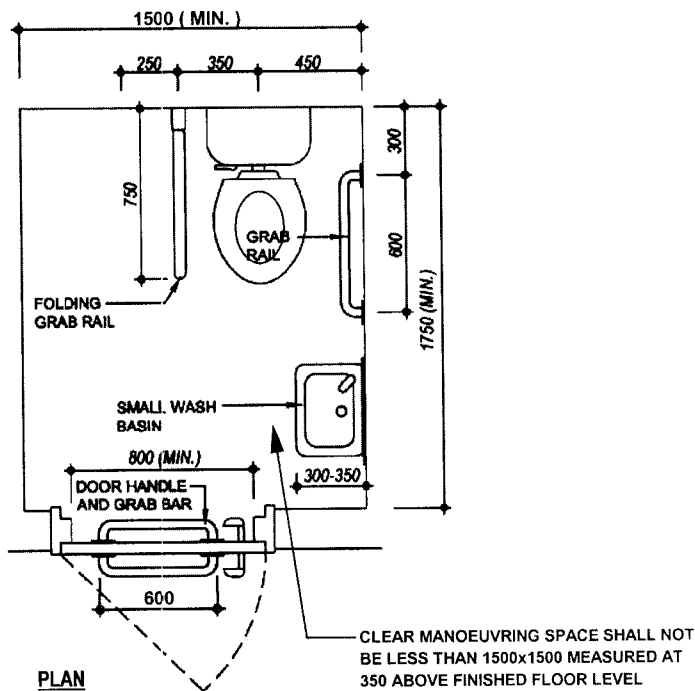

PLAN

*ALL DIMENSIONS ARE IN mm
 DIMENSIONS PRINTED IN BOLD FORM DENOTE OBLIGATORY REQUIREMENT
 DIMENSIONS PRINTED IN ITALIC FORM DENOTE RECOMMENDED REQUIREMENT

(Opposite - Handed Layout is Acceptable)

Figure 24 – Accessible Toilet

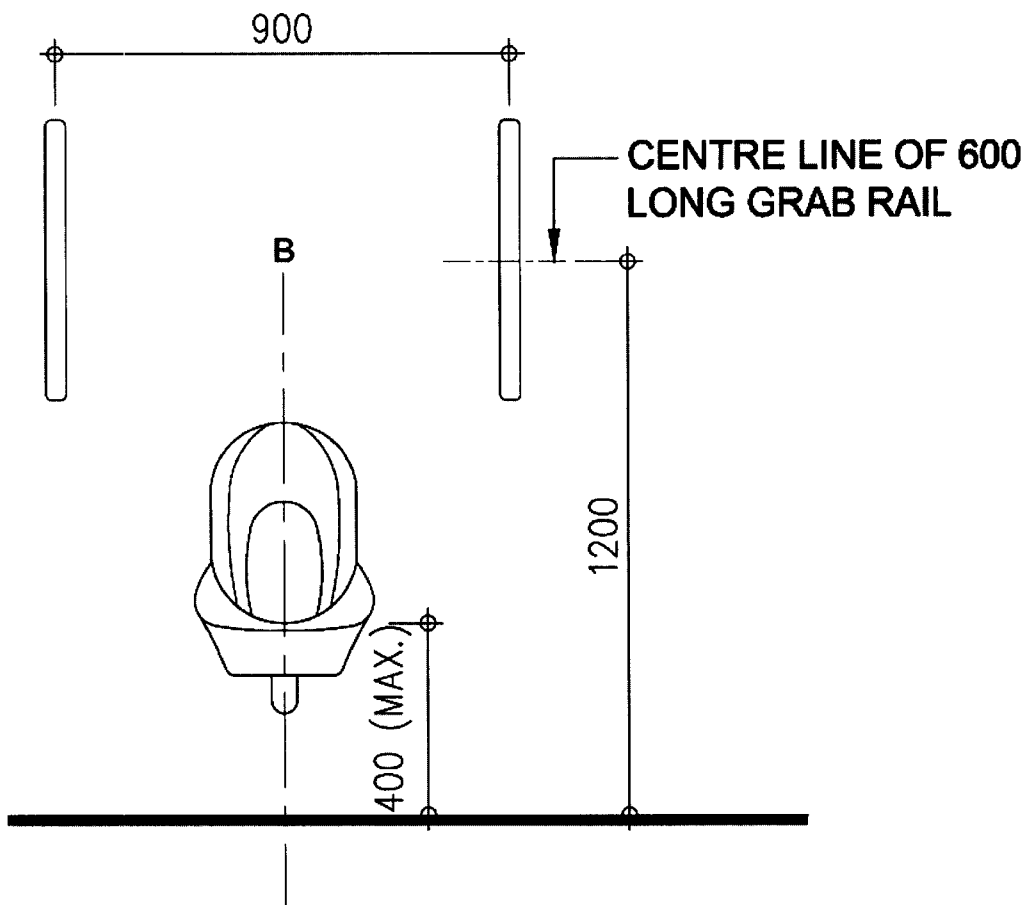

*ALL DIMENSIONS ARE IN mm

Figure 25 – Accessible Urinal

BEST PRACTICE SECTION

4.8.4 Design Considerations

- (a) Adequate and convenient provision of toileting facilities commensurate with the anticipated use by all users either with or without assistance from others.
- (b) Appropriate sanitary accommodation should be available to all, including persons with ambulant disabilities, wheelchair users, the elderly and people of either sex with babies and small children.
- (c) Provision of a safe environment capable of accommodating the toileting needs and requirements of persons with a disability or the elderly.

4.8.4 Design Considerations (Cont'd)

- (d) If there is adequate space inside the toilet or cubicle units, double swing door open both inwards and outwards or sliding door may be provided to enable assistance during emergency situations.
- (e) Urinals should be accessible and can be easily found by persons with visual impairment. The grab rails for aiding the elderly and tactile surface materials for aiding persons with visual impairment should be provided.
- (f) Accessible unisex toilet facilities can serve both sexes, those with or without assistance, and accommodate a greater number of users. It is more easily identified than a facility in a separate-sex toilet and more likely to be available when required, particularly as the elderly and some persons with a disability need to use toilets more frequently than others. In addition, a unisex facility enables assistants of either sex to assist the user.
- (g) There is a tendency for the specification of sanitary fittings and fixtures to be in white colour to make cleanliness easily observable. Often the fittings are set against light or white coloured tiling which makes clear identification difficult for the persons with visual impairment. Sanitary fittings should have luminous contrast or colour contrast against the background finishes.

4.8.5 Recommended Design Requirements

Unisex Facilities

- (a) W.C. cubicles should, where possible, be unisex and accessible from a corridor so that they can be used by either sex with assistance from members of the opposite sex, if necessary.
- (b) If two or more accessible unisex facilities are provided, at least one should be of opposite handed layout to the other(s).

W.C. Cubicles

- (c) The clear distance between the watercloset and the wash basin should not be more than 600 mm for the users' convenience after toileting. The clear manoeuvring space within the cubicle shall not be less than 1500 mm x 1950 mm.
- (d) The angle between the two grab rails should be within the range of 80° to 90°.

Toilet / Compartment Doors

- (e) Double swing doors which open both inwards and outwards may be provided in any toilets or cubicles. Sliding door is equally acceptable provided that it is not heavy or awkward to use.

4.8.5 Recommended Design Requirements (Cont'd)

Diaper-changing Facilities

- (f) Diaper-changing facilities should be provided in all toilets unless there is absolutely no sufficient space (see **Figure 26**).

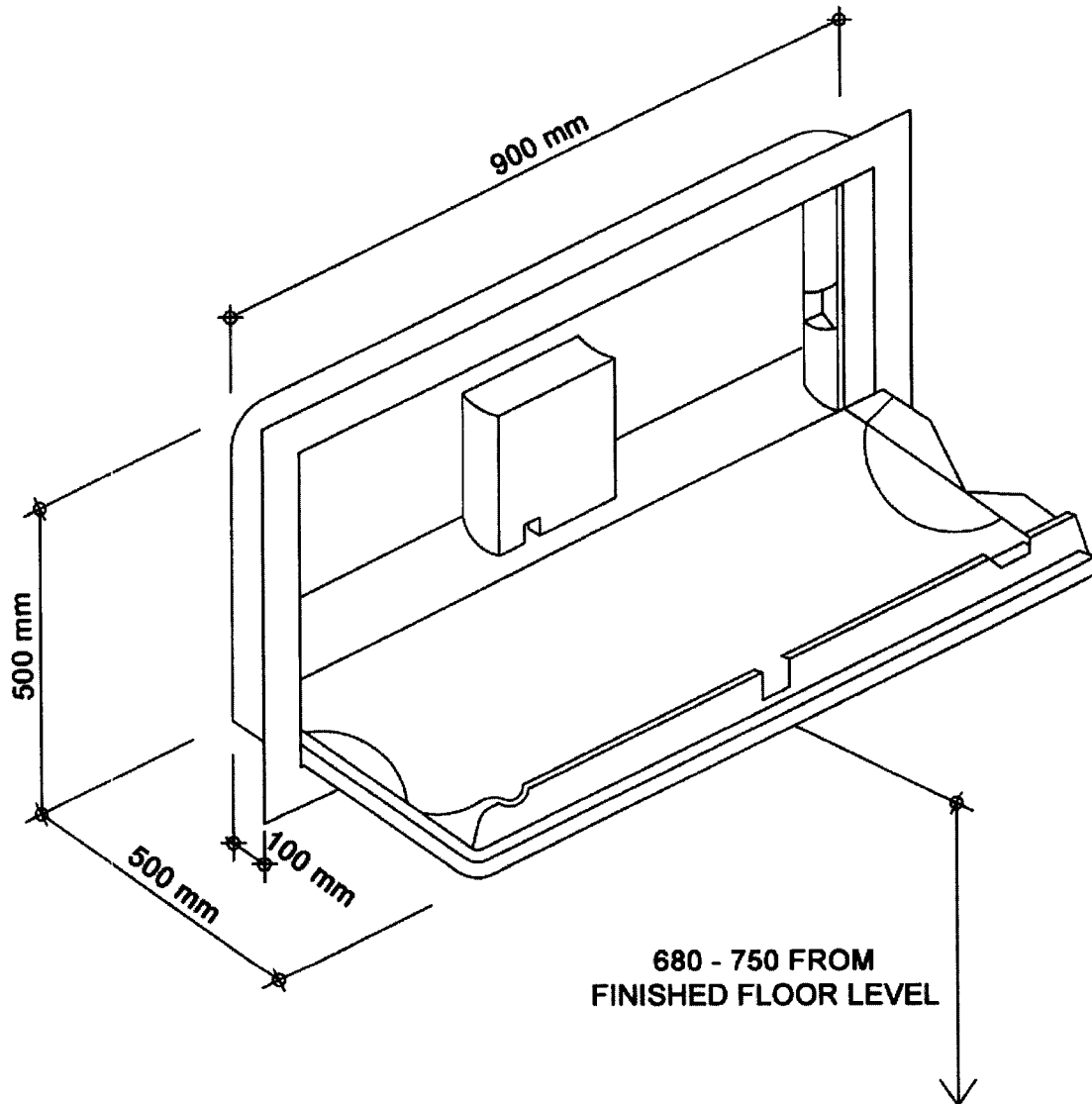

*ALL DIMENSIONS ARE IN mm

Figure 26 – Flap-type Diaper Changing Station

4.8.5 Recommended Design Requirements (Cont'd)

Bathroom / Shower Compartment

- (g) The floor of the bathroom and the shower compartment should be slip-resistant with a minimum static coefficient of friction of "Good" grading (see **Appendix C**) and self-draining.

Luminous Contrast

- (h) Wall tiling should have a minimum luminous contrast of 30% with sanitary appliances and fittings, grab rails and toilet roll holders, etc.

Avoidance of Obstruction

- (i) Waste pipe, disposal bins and other fittings within the toilet should be located to avoid any obstruction or creating a tripping hazard including those under the wash basin.
- (j) Toilets and W.C. cubicles for use by persons with a disability should be located to avoid proximity to or obstruction by exit doors to the staircase.

Emergency Call Bell

- (k) An additional emergency call bell near the toilet seat should be provided, if practicable.

Large Size Symbols

- (l) Large size symbols with luminous contrast for male and female toilets should be used.

4.9 BATHROOMS AND SHOWER COMPARTMENTS

4.9.1 This section sets out requirements for accessible bathrooms and shower compartments as required under **Clause 3.2.3(b)**.

MANDATORY SECTION

4.9.2 Performance Objectives

The accessible bathrooms and shower compartments shall be so designed and equipped with sanitary fittings and installations to allow persons with a disability and the elderly to use them without assistance from others.

4.9.3 Obligatory Design Requirements

Bathtubs

- (a) (i) There shall be a clear floor space of not less than 1500mm x 800 mm in front of the bathtub (see **Figure 27**);
- (ii) The bathtub shall be provided with a seat of not less than 250 mm in width (see **Figure 27**); and
- (iii) The bathtub shall have a maximum height of 380 mm.

Grab Rails for Bathtub

- (b) Grab rails shall: -
 - (i) not rotate within their fixing fittings;
 - (ii) have a diameter between 32 mm – 40 mm and have a grip space of not less than 30 mm clear from the wall;
 - (iii) be at least 900 mm long, installed horizontally or slanting at an angle not exceeding 20 degrees along the length of the bathtub and at a height between 150 mm to 300 mm above the rim of the bathtub ; and
 - (iv) be at least 600 mm long, installed vertically at the plug end of the bathtub adjacent to the clear floor space with the lower end 150 mm to 300 mm above the rim of the bathtub.

Faucets and Controls

- (c) Faucets and other controls shall: -
 - (i) have lever type handles at least 75mm long from the centre of rotation to the handle tip;
 - (ii) be installed at the plug end of the bathtub; and
 - (iii) be not more than 450 mm above the rim of the bathtub.

4.9.3 Obligatory Design Requirements (Cont'd)

Shower Heads

- (d) Shower heads shall: -
 - (i) be of the hand-held type;
 - (ii) be provided with a hose not less than 1500 mm in length; and
 - (iii) be provided with a wall mounting bracket to allow use in a fixed position.

Where shower heads are mounted on a vertical bar, the bar shall:-

- (iv) have a minimum length of 500 mm with the lower end not less than 450 mm above the finished floor level; and
- (v) be installed so as not to obstruct the use of grab rails and be so mounted to be able to carry a static load of 150kg in case they are mistakenly used as a grab rail.

Shower Compartments

- (e) Shower compartments shall have internal dimensions of not less than 1500 mm x 900 mm. The minimum clear floor space in front of the shower entrance shall be 1500 mm x 800 mm with the 1500 mm dimension parallel to the shower entrance.

Grab Rails for Shower Compartments

- (f) Grab rails for shower compartments shall: -
 - (i) comply with **Clause 4.9.3(b)(i) and (ii)**;
 - (ii) be L-shaped or two bars arranged in L-shaped configuration and not be less than 750 mm by 900 mm in length;
 - (iii) be installed at a height between 700 mm and 800 mm from the shower floor; and
 - (iv) be capable of carrying a static load of 150kg.

Thresholds

- (g) Thresholds for roll-in shower compartments shall: -
 - (i) not be more than 13 mm high; and
 - (ii) have bevelled edges.

4.9.3 Obligatory Design Requirements (Cont'd)

Shower Seats

- (h) The shower seats shall: -
 - (i) have a rounded edge and be self-draining ;
 - (ii) be installed on the wall next to the taps and controls;
 - (iii) not be less than 550 mm in width and 400 mm in depth; and
 - (iv) be installed at a height between 430 mm and 480 mm from the top of the seat to the finished floor level.

BEST PRACTICE SECTION

4.9.4 Design Considerations

- (a) Wheelchair users generally require larger space for access to the bathrooms. A proportion of guest rooms should be designed to accommodate the need of wheelchair users.

4.9.5 Recommended Design Requirements

- (a) Faucets and other controls should be installed between the centre line and the outer edge of the bathtub.

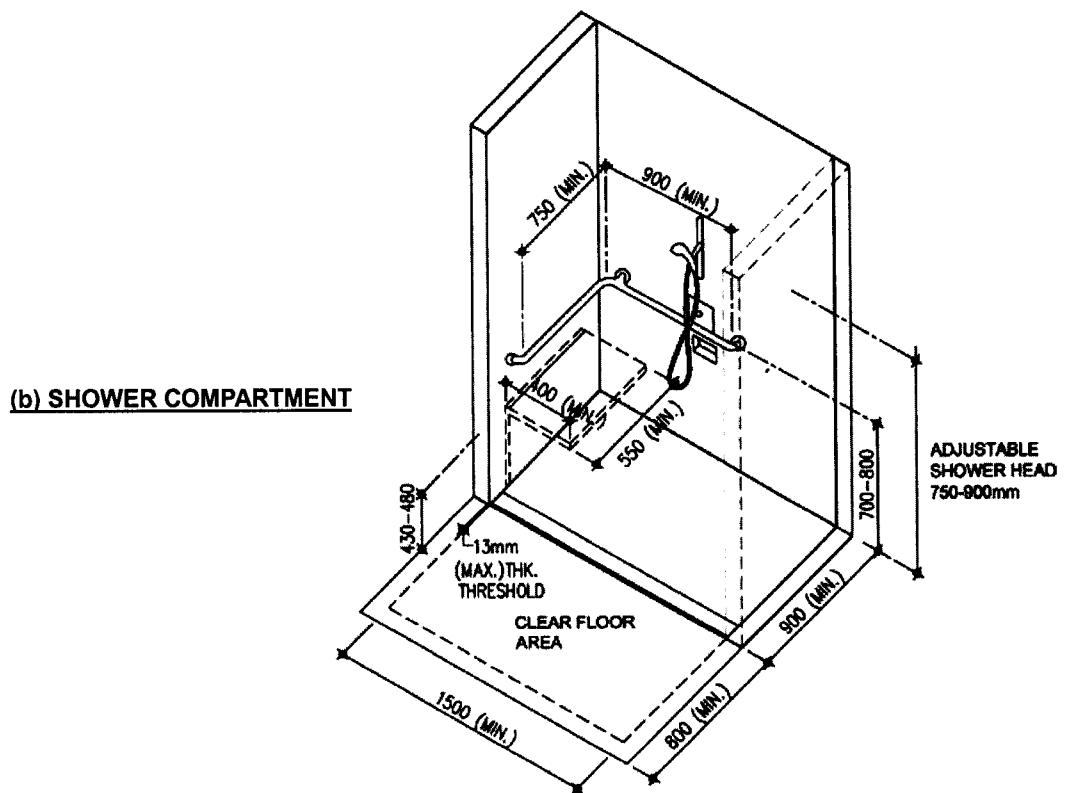
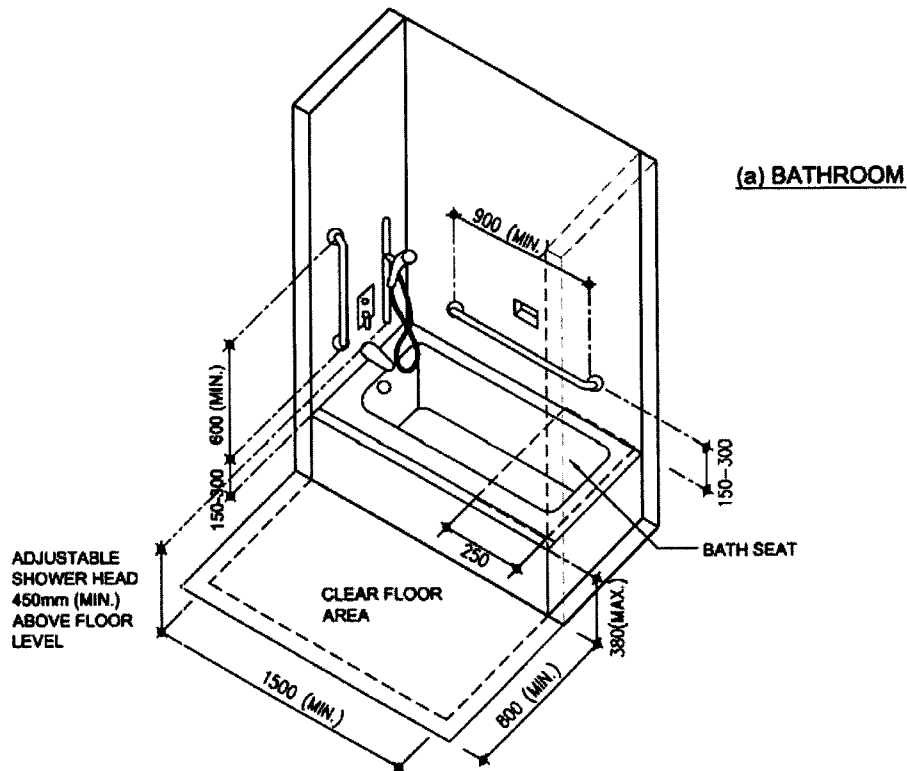

*ALL DIMENSIONS ARE IN mm

Figure 27 - Example of Bathroom and Shower Compartment

4.10 SIGNS

4.10.1 It is essential that suitable signs are erected at prominent and conspicuous positions inside and outside a building to indicate clearly the exact locations of facilities that are available for use by persons with a disability. To design an effective signage system, the needs of different types of users in a building and the complexity of the building layout must be considered.

MANDATORY SECTION

4.10.2 Performance Objectives

Signs shall give clear directions, information and instructions for the users of the building.

4.10.3 Obligatory Design Requirements

Signs shall be erected to indicate clearly the exact locations of facilities available for use by persons with a disability.

The International Symbol

- (a) The international symbol of accessibility shall be the wheelchair figure in white on a blue background and is to be provided at conspicuous location as shown in **Figure 28** for the purposes of identifying/advertising /signifying:
- (i) accessible entrance(s) to the building;
 - (ii) accessible exit(s) from the building;
 - (iii) reserved car parking facilities;
 - (iv) the location of toilets for persons with a disability;
 - (v) usable vertical circulation facilities;
 - (vi) usable cloakroom facilities; and
 - (vii) the availability of special services of information / service counter, telephone in the building.

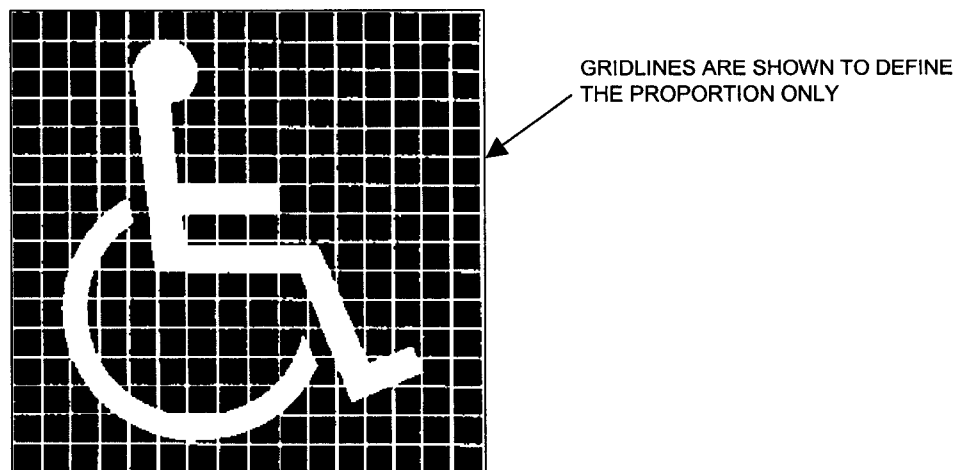
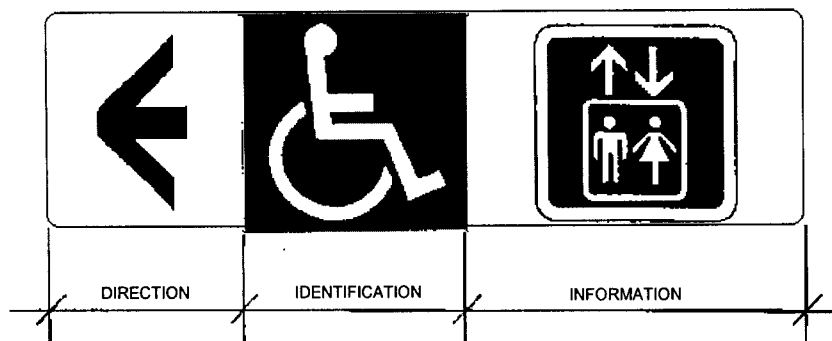

Figure 28 – Proportional Layout for International Symbol of Accessibility

4.10.3 Obligatory Design Requirements (Cont'd)

Directional Signs

- (b) Directional arrows and visual information shall be provided at conspicuous location in conjunction with the international symbol for accessibility to guide persons with a disability to the exact locations of the accessible facilities. For illustration, see **Figure 29**.



(A) EXAMPLE OF A SIGN IDENTIFYING A FACILITY AND INDICATING ITS DIRECTION USING A STANDARD SYMBOL [LIFT]

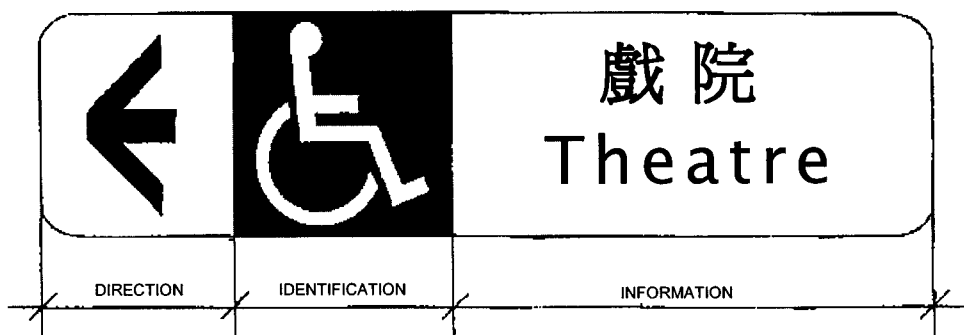

(B) EXAMPLE OF A SIGN IDENTIFYING A FACILITY AND INDICATING ITS DIRECTION USING A WORD

Figure 29 – Directional Signs

Size

- (c) The height of signs shall be not less than the following :

60 mm for doors
110 mm for corridors
200 mm for external use

4.10.3 Obligatory Design Requirements (Cont'd)

Sign for Persons with Hearing Impairment

- (d) International symbol of access for hearing loss as shown in **Figure 30** shall be provided if there is an assistive listening system provided for persons with hearing impairment.

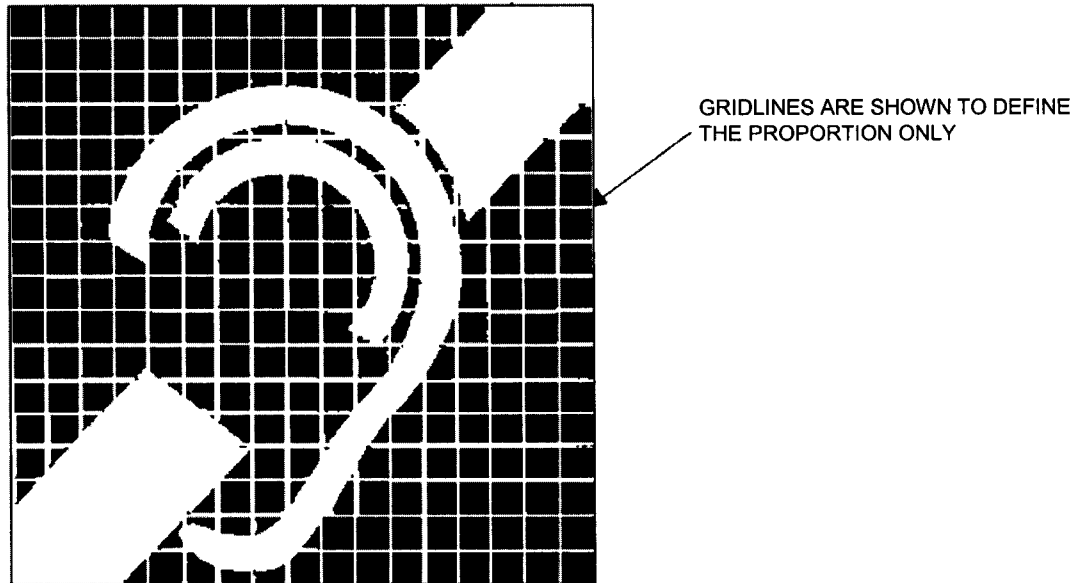
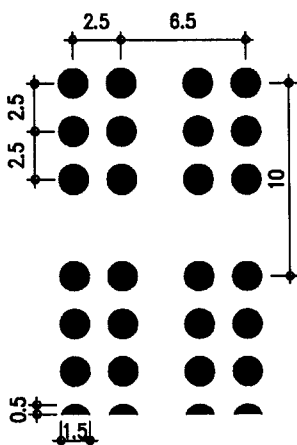

Figure 30 – Proportional Layout for International Symbol of Access for Hearing Loss

4.10.3 Obligatory Design Requirements (Cont'd)

Braille and Tactile Sign

- (e) Braille and tactile sign shall be installed on adjacent wall or door of public toilet to indicate whether the toilet is for male, female or unisex. The sign shall be placed at 900 mm to 1500 mm above the finished floor level. Specification of Braille cells is shown in **Figure 31**.
- (f) If there is no door, the sign shall be provided on the wall in front of the toilets.
- (g) A Braille and tactile fire exit map as shown in **Figure 32** shall be provided directly above the call button of the accessible lift in the lobby of the accessible lift in a building if a fire exit map for the use of the public is provided. The map shall be placed at 800 mm to 1200 mm above the finished floor level.



Dot Spacing :	2.5 mm	Character Spacing :	6.5 mm
Dot Height :	0.5 mm	Line Spacing :	10.0 mm
Dot base diameter :	1.5 mm		

Figure 31 – Specification of Braille Cells

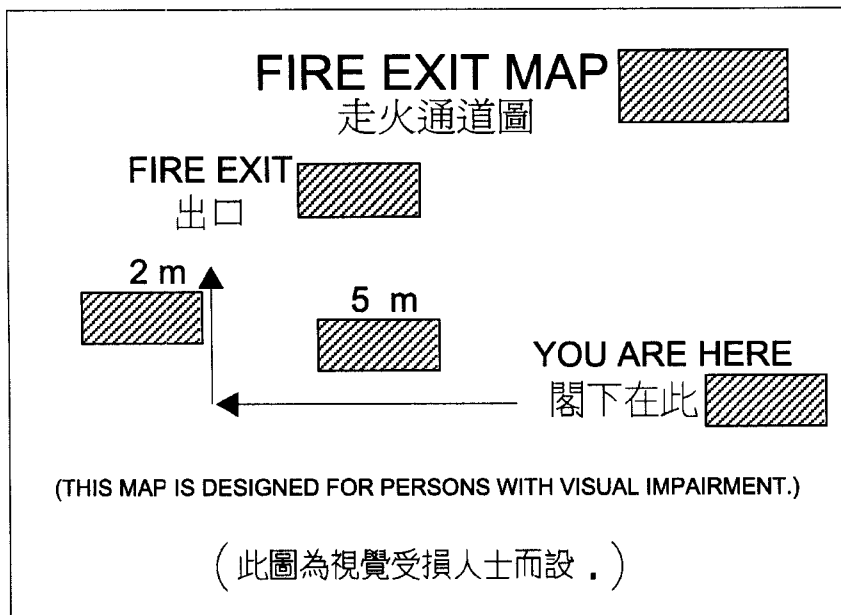

Note: The 2m and 5m as shown on the Map are hypothetical figures only, they shall be subject to actual site condition.

 Braille information

Figure 32 – Braille and Tactile Fire Exit Map

4.10.4 Special Obligatory Design Requirements to Assist Persons with Visual/Hearing Impairment to Various Uses of Buildings in Table 2

- (a) If a floor plan for the use of the public is provided, Braille and tactile floor plan showing the main entrance, public toilet and major common facilities shall be provided in a place in that building which is conspicuous to persons with visual impairment.
- (b) Tactile guide path shall be installed from a point of access at the lot boundary in compliance with **Clause 4.1.3 (c)** to the main entrance of the building and from the main entrance to lift zone, the nearest accessible toilet, information/service counter, Braille and tactile floor plan and staircase as illustrated in **Figures 33, 34 and 35** respectively.
- (c) If visual display board (such as LED) is provided, it shall be able to display the essence of the information broadcasted by the public address system in the building. Examples include display boards to inform travellers of the arrival and destination of the MTR trains.

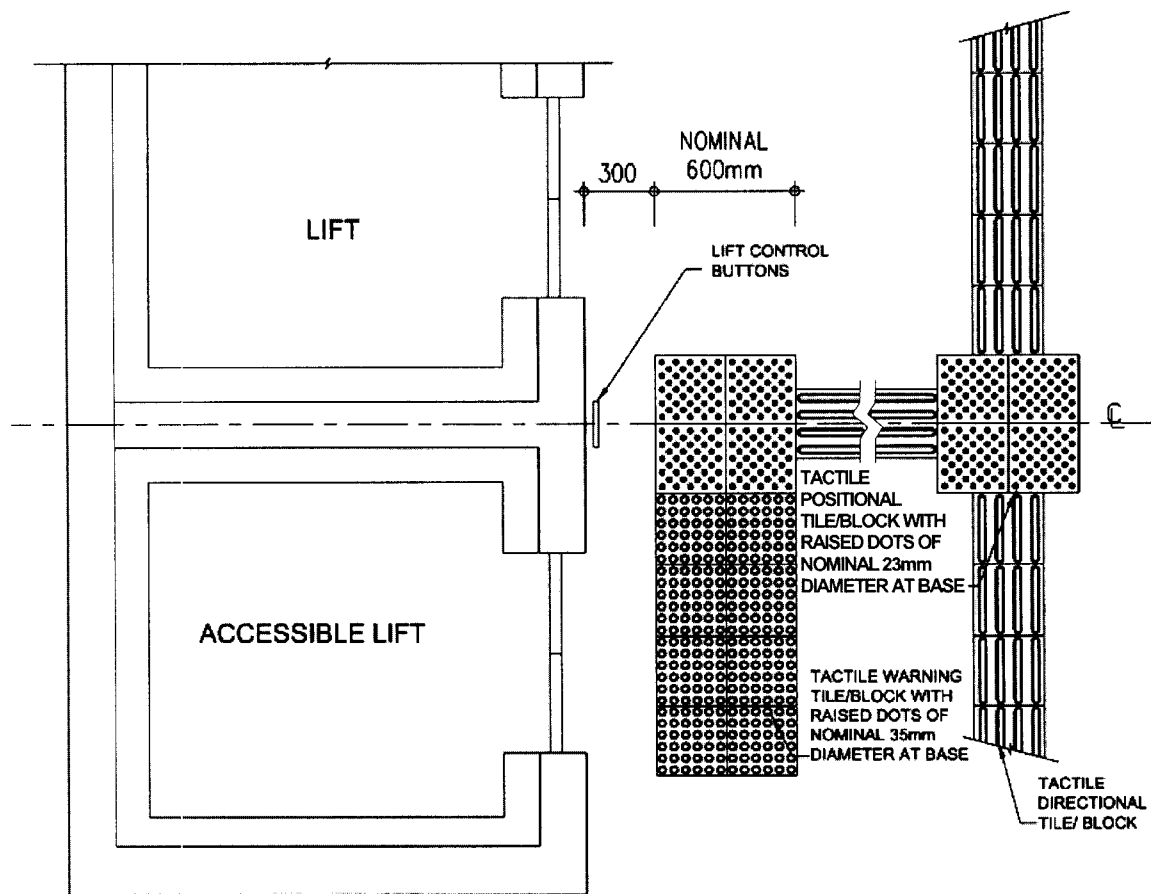

*ALL DIMENSIONS ARE IN mm

Figure 33 – Tactile Guide Path to Lift Zone

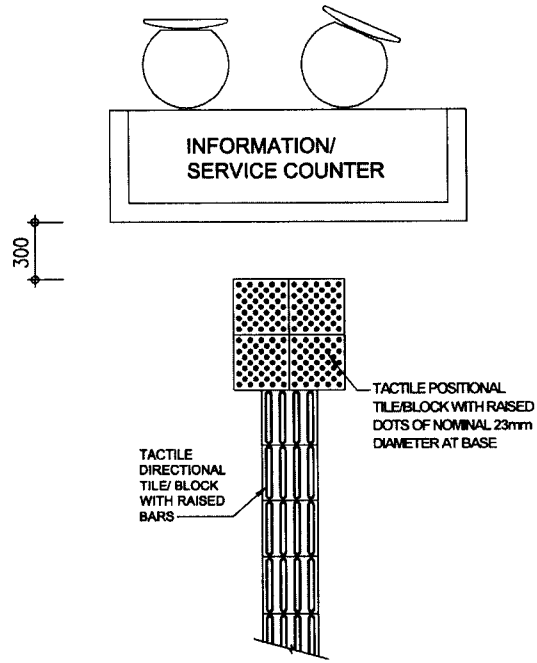

*ALL DIMENSIONS ARE IN mm

Figure 34 – Tactile Guide Path to Information / Service Counter

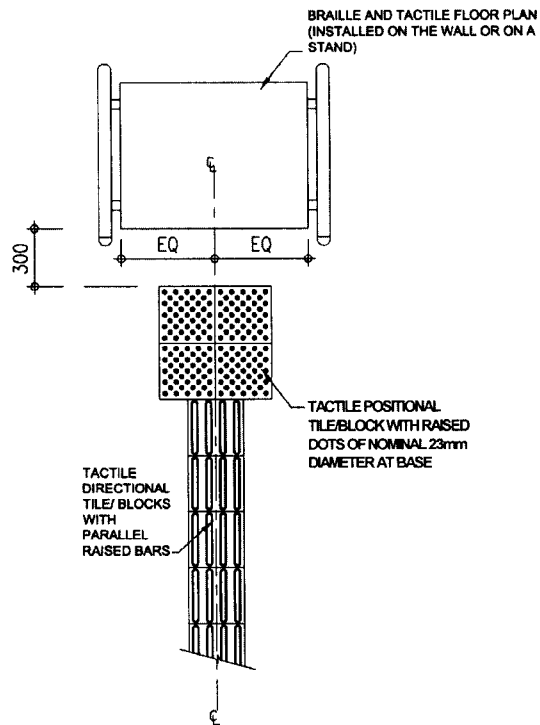

*ALL DIMENSIONS ARE IN mm

Figure 35 – Tactile Guide Path to Tactile / Braille Directory Map / Floor Plan

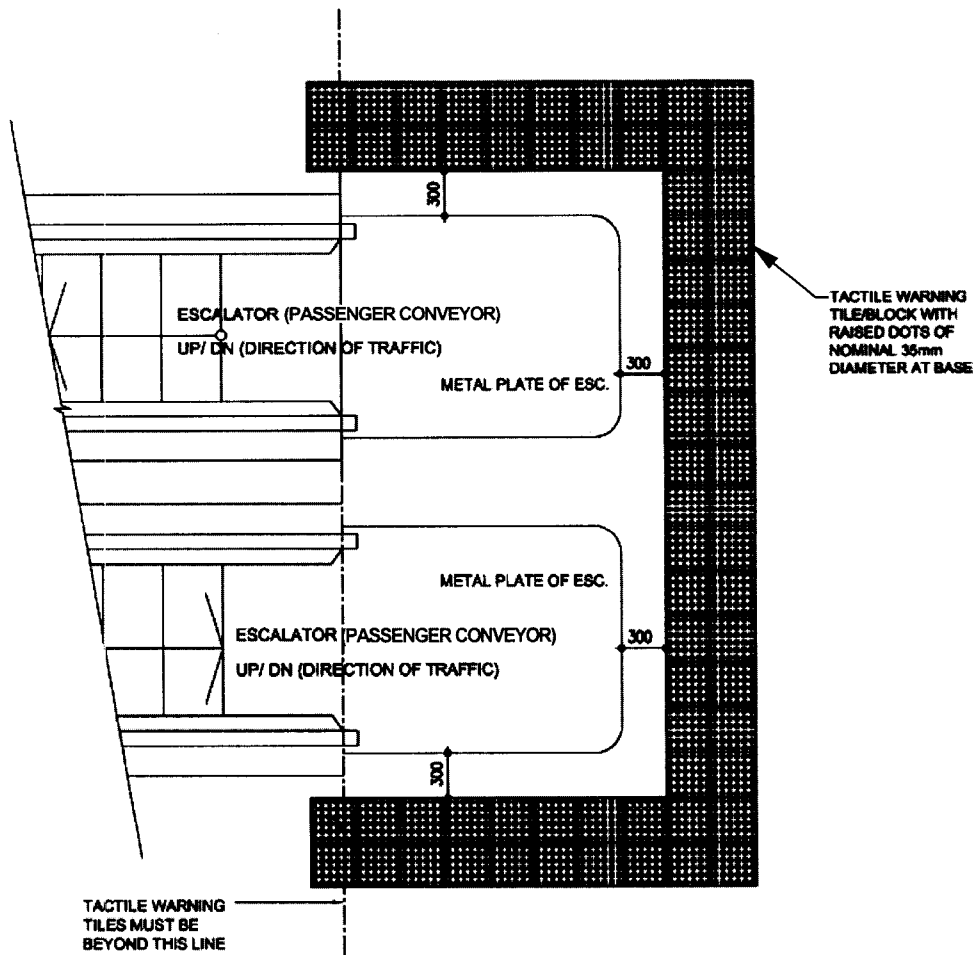

*ALL DIMENSIONS ARE IN mm

Figure 36 – Tactile Warning Strip to Escalator

BEST PRACTICE SECTION

4.10.5 Design Considerations

- (a) Signs should be clear and easy to read and understand in order to assist persons with intellectual, cognitive and sensory disabilities.
- (b) International symbols are to be used for purpose of standardization and apprehension by all persons with a disability residing in Hong Kong or visiting from overseas. Examples of standard public information symbols are shown in **Figure 37**.
- (c) Prominent signs with high color and luminous contrasts as well as special shapes are recommended to be used for the elderly.
- (d) Safety for persons with visual impairment should be considered. Information such as distance to the destination, name of building etc. should be conveyed to the persons with visual impairment. The suggested provisions are voice message, Braille and signs with high luminous contrast.
- (e) To account for persons with visual impairment, larger fonts, more prominent and well-defined shapes of signs are recommended.
- (f) For categories of buildings as required in **Table 2**, tactile guide paths should be provided for persons with visual impairment from the main entrance to lift zone, information/service counter, Braille and tactile floor plan, and staircase/escalator provided with audible signals. Braille and tactile floor plan showing the locations of major common facilities should be provided in a location in that building which is conspicuous to persons with visual impairment.





	Facilities for blind or partially sighted people
	World Federation of the Deaf sign to indicate facilities for deaf people
	Equipment to enhance microphone sound for people whose hearing aid is fitted with a "T" switch
	Equipment to enhance microphone sound through an infrared receiver

Figure 37 — Examples of Public Information Symbols

4.10.6 Recommended Design Requirements

Location

- (a) Sign should be erected to indicate clearly the locations of accessible routes through the building.

Luminous Contrast

- (b) Luminous contrast of not less than 70% should be provided to differentiate the international symbol of accessibility from the background, either light-on-dark or dark-on-light. The commonly employed colours are white for the wheelchair figure and blue for the background.

4.10.6 Recommended Design Requirements (Cont'd)

Lettering and Colour

- (c) Lettering should be plain and legible, e.g. Helvetica (medium) using lower case letters except for initial capitals.
- (d) Corners of sign should be rounded.
- (e) Chinese characters should be legible e.g. "Haak Tai" style.
- (f) Sign should be in raised characters.
- (g) The system of sign used should be clear and consistent.

Braille and Tactile Sign / Audible Sign

- (h) Braille and tactile building name and address (i.e., street name with number) or a device which when activated will provide the same information in audible form should be provided on both sides of the building entrance at a height of between 900 mm and 1500 mm above the finished floor level.
- (i) If public address system is provided to convey information to the public in a building, then a means of conveying the same or equivalent information to persons with hearing impairment should also be provided.
- (j) If a floor plan for the use of the public is provided, Braille and tactile floor plan with audible device indicating the main entrance, public toilet and major common facilities should be provided in a place in that building which is conspicuous to persons with visual impairment.

Visual Sign

- (k) Visual display board (such as LED) should be provided in public waiting areas other than those required in **Table 2** and where there is an announcer installed to regularly convey information to the people inside. The visual display board should be able to display the essence of the information so announced.

4.11 INFORMATION / SERVICE COUNTERS

4.11.1 Information/service counters refer to provisions for assistance in a building where the public or a section of the public is likely to approach to seek services and/or information.

MANDATORY SECTION

4.11.2 Performance Objectives

Where information/service counters are provided, they shall be accessible and easily identifiable from a building entrance by all persons with or without a disability.

4.11.3 Obligatory Design Requirements

- (a) Public information/service counters shall be provided to various categories of buildings as specified in **Table 2**, and there shall be at least one public information/service counter built with a portion not higher than 750mm above the finished floor level and not less than 750 mm wide to assist wheelchair users (see **Figures 38 and 39**).
- (b) There shall be at least one public information/service counter provided with an assistive listening system where the background is noisy or counters are provided with screen.
- (c) Leg space of a depth between 400 mm – 600 mm and a height of not less than 680 mm above finished floor level shall be provided.

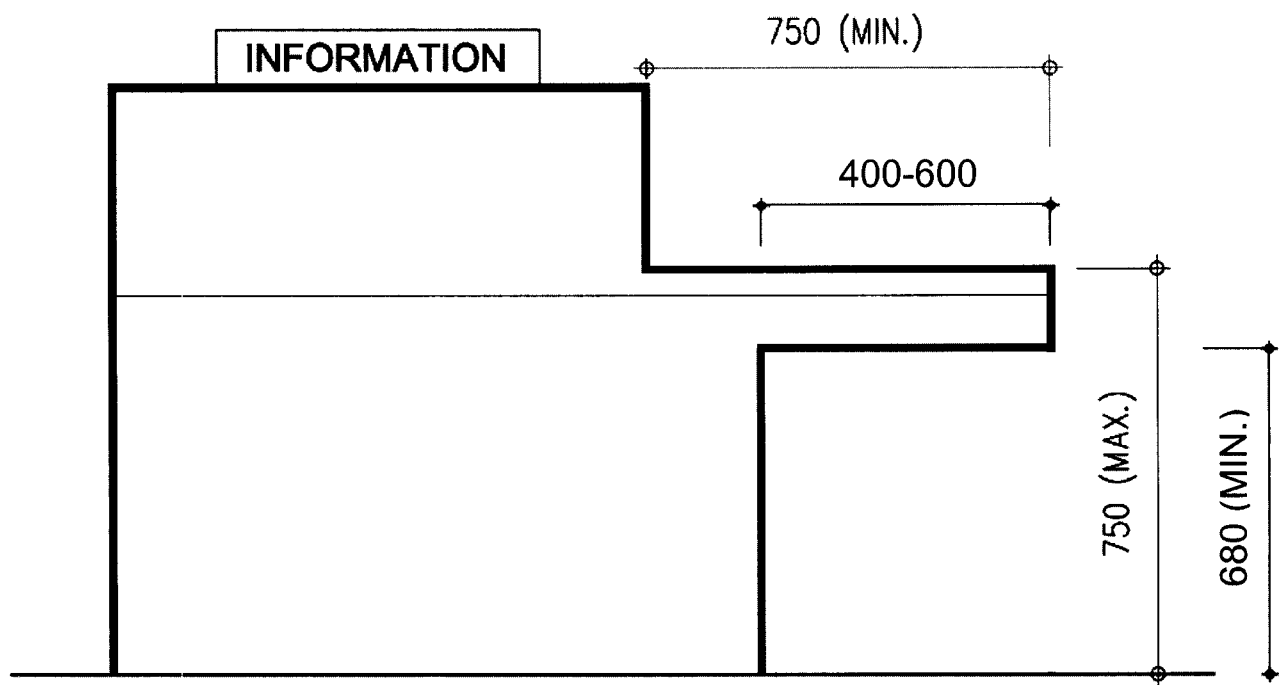

*ALL DIMENSIONS ARE IN mm

Figure 38 - Front View of Information / Service Counter for Wheelchair Users

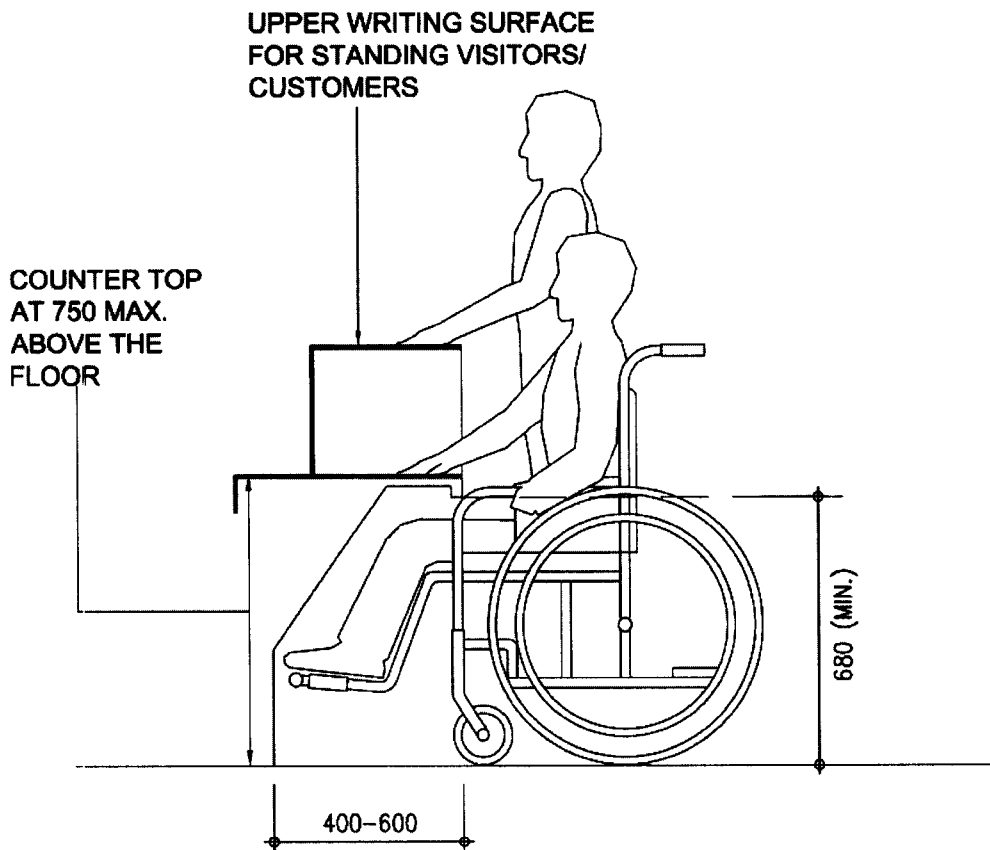

*ALL DIMENSIONS ARE IN mm

Figure 39 – Key Heights of Counters and Reception Desks

BEST PRACTICE SECTION

4.11.4 Design Considerations

- (a) The approach to the counter should be direct, clear and unobstructed.
- (b) Signs associated with counters should be located and visible to wheelchair users.
- (c) Counters should be located away from the entrance if disturbance of noise from external is anticipated.
- (d) Provision of permanent or temporary control barriers for queuing should allow space for manoeuvring of wheelchairs.
- (e) For the convenience of the people using sticks, a recess should be provided to the information/service counter for them to place the assistive tools.

CHAPTER 5

BUILDING SERVICES DESIGN REQUIREMENTS

5.1 SWITCHES AND CONTROLS

- 5.1.1 This section is applicable to operable part of controls such as electrical switches, wall socket outlets and controls of other electrical and mechanical equipment.
- 5.1.2 Switches, socket outlets and controls for lighting and other equipment shall be located so that they are easily reachable for all users.

BEST PRACTICE SECTION

5.1.3 Design Considerations

- (a) Ease of operation, visibility, reachable height and free from obstruction are key factors that affect the use of building services by persons with a disability.
- (b) All outlets, switches and controls should be positioned consistently in relation to doorways and corners within a building and in a logical sequence of passage through the building.
- (c) Switches close to the floor or skirting are difficult to reach and dangerous because the users have to stoop or kneel to operate them. The higher the socket outlet, the easier it is to push in or pull out the plug. However, there may be exceptions to height requirements for some socket outlets, e.g. those set into the raised flooring in open plan offices.
- (d) Operation of controls intended to be used by persons with a disability should not require the use of both hands simultaneously.
- (e) To cater for persons with visual impairment, controls should be in colour and luminous contrast with the background, and with embossed information on them for tactile reading.

5.1.4 Recommended Design Requirements

Positioning

- (a) Except as otherwise provided in **Section 5.7** for lifts, the controls for the operation of building services or safety devices including electrical switches, light switches, thermostats, intercom switches and card reading machines which are intended to be accessible to wheelchair users should be located between 450 mm and 1200 mm above the finished floor level (see **Figure 40**).

5.1.4 Recommended Design Requirements (Cont'd)

Positioning (Cont'd)

- (b) Electric sockets should be located not lower than 450 mm above the finished floor level.

Luminous Contrast

- (c) Light switches and socket outlets should have a minimum luminous contrast of 30% with their background to indicate their locations.

Controls

- (d) Controls should:
 - (i) have a minimum luminous contrast of 30% with the background finishes;
 - (ii) not require tight grasping or twisting;
 - (iii) be visible from a seated position; and
 - (iv) not be of small button type.

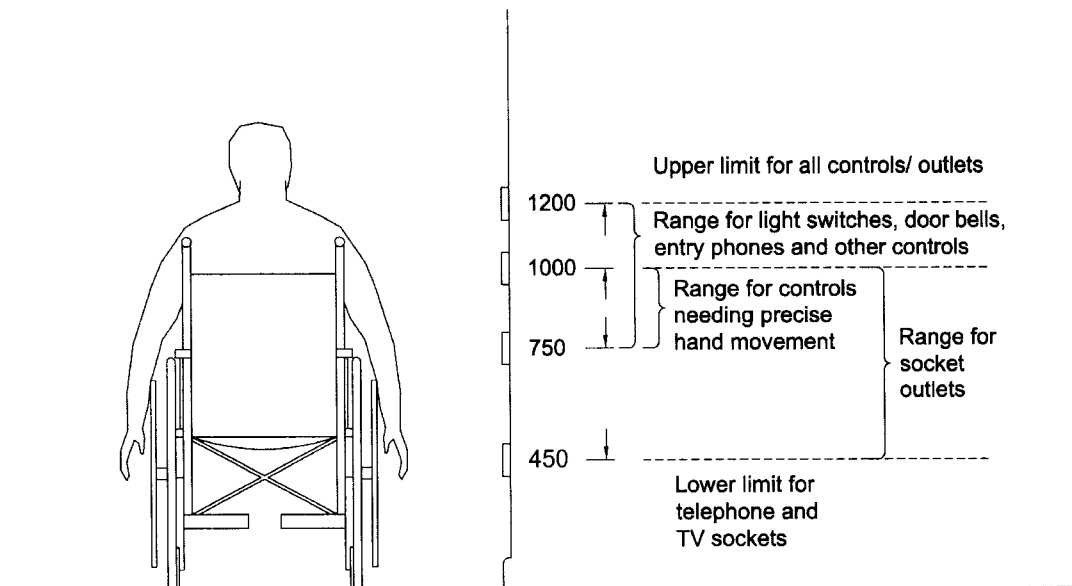

*ALL DIMENSIONS ARE IN mm

Figure 40 – Heights of Switches and Controls

5.2 ILLUMINATION

5.2.1 This section sets out the requirements for lighting provisions.

MANDATORY SECTION

5.2.2 Performance Objectives

Sufficient level of illumination shall be provided in order to help people to apprehend the physical environment of the space they have entered or to move around safely.

5.2.3 Obligatory Design Requirements

Sign Surface

- (a) Accessible signs under **Section 4.10** shall have illumination level on the sign surface of not less than 120 lux.

Illumination Level

- (b) The following designated areas of a building, where reasonably expected to be used by the public or occupants of the building during the period of normal use or occupation or when required, shall have minimum illumination level measured at the finished floor level along the centre line of the passageway as follows: -

Ground floor entrance lobby and lift	120 lux
Lift lobby of upper floors, corridors, accessible paths and staircases	85 lux

Such provision may be provided through automatic or manual switching devices.

BEST PRACTICE SECTION

5.2.4 Design Considerations

- (a) Artificial lighting should be designed to give uniform illumination and good colour rendering of all surfaces, without creating glare, or pools of bright light and strong shadows.
- (b) Where appropriate, lighting should be so designed to illuminate the face of a person speaking in order to make communication easier.

5.2.5 Recommended Design Requirements

Common Areas

- (a) Common areas of a building should have an illumination level of not less than 120 lux measured at the finished floor level.

Lighting for Steps

- (b) Lighting with lower illumination level should be provided at the entrances and exits to provide a contrast between the treads and the risers.

Illumination Level

- (c) Uniformity of illumination level should be maintained throughout the designated confined areas such as staircases, corridors or the like.
- (d) Higher illumination level at the entrance doors to flats and the exit doors should be provided.

5.3 FIRE ALARM SYSTEMS

5.3.1 Persons with hearing impairment depend on visual cues to alert them of emergencies. Persons with hearing impairment may need a visible as well as audible alarm which is only sufficient to deliver warning to a normal person.

MANDATORY SECTION

5.3.2 Performance Objectives

Where fire alarm systems are provided in areas of a building required to be accessible, the alarm shall emit both audible and visible signals.

5.3.3 Obligatory Design Requirements

Visual Alarm

- (a) Subject to paragraph (b), visual alarm signal shall be provided to form part of the fire alarm system in the form of a flashing red light, labelled “**Fire Alarm 火警**” in both English and Chinese. It shall be indicated on separate plate affixed nearby or engraved on the light cover. The alarm shall be installed at a prominent location which shall be readily noticeable when activated in the categories of buildings as specified in **Table 2**.
- (b) The provision of visual alarm shall not apply to all exit staircases as required under the Code of Practice for the Provision of Means of Escape in Case of Fire including the smoke lobbies adjoining the exit staircase, and the following areas: -

Domestic use	- domestic units
Office	- areas accessible to staff only, e.g. offices, store rooms, plant rooms, staff toilets, etc.
Department store and shopping complex	- areas not accessible to customers, visitors, e.g. offices, store rooms, plant rooms, staff toilets, etc.
Hotel, guesthouse, hostel and bank	- areas not accessible to guests, customers, visitors, e.g. kitchens, plant rooms, staff toilets, offices, back of house facilities, etc.
Place for worship	- areas not accessible to worshippers, visitors, e.g. offices, staff toilets, etc.

5.3.3 Obligatory Design Requirements (Cont'd)

Visual Alarm (Cont'd)

Cinema, theatre, concert hall, stadium, museum, theme park and purpose-built family amusement centre	- areas not accessible to the visitors, spectators, audience, e.g. projector rooms, offices, store rooms, plant rooms, staff toilets, etc.
School, college, university	- areas accessible to staff only, e.g. offices, store rooms, plant rooms, staff toilets, staff quarters, etc.
Factory, workshop and place for industrial use	- areas accessible to staff only, e.g. offices, store rooms, plant rooms, staff toilets, etc.
Sports complex and public swimming pool complex	- areas not accessible to visitors, athletes, spectators, e.g. plant rooms, offices, store rooms, staff toilets, etc.
Restaurant and food court	- areas not accessible to customers, visitors, e.g. offices, kitchens, store rooms, plant rooms, staff toilets, etc.
Indoor market and supermarket	- areas not accessible to customers, visitors, e.g. offices, store rooms, plant rooms, staff toilets, etc.
Hospital, purpose-built clinic, residential home for the elderly and welfare centre	- areas not accessible to patients, inmates, visitors, e.g. kitchens, plant rooms, staff toilets, offices, laboratories, back of house facilities, staff quarters, etc.
Club House	- areas accessible to staff only, e.g. offices, kitchens, store rooms, plant rooms, staff toilets, etc.
Transport station, interchange, passenger terminal	- areas accessible to staff only, e.g. plant rooms, station offices, regulator's offices, staff toilets, etc.
Carpark	- areas not accessible to customers, visitors, e.g. shroff offices, store rooms, plant rooms, staff toilets, etc.

5.3.3 Obligatory Design Requirements (Cont'd)

Positioning of Call Points

- (c) The manual fire alarm call points or activation controls, e.g. breakglass units, in places which are intended to be accessible to wheelchair users, shall be positioned at prominent and accessible locations and installed in accordance with the Code of Practice for Minimum Fire Service Installations and Equipment and the Code of Practice for Inspection, Testing and Maintenance of Installations and Equipment or Fire Services Department Circular Letter.

Audible Alarm

- (d) Audible alarm shall comply with the requirements of the Code of Practice for Minimum Fire Service Installations and Equipment and the Code of Practice for Inspection, Testing and Maintenance of Installations and Equipment published by the Director of Fire Services.

BEST PRACTICE SECTION

5.3.4 Design Considerations

- (a) Audible and visual alarm may not be appropriate for use in hospitals and some specialized medical facilities, such as operating rooms, where it is not intended to alert or alarm patients who are incapable of independent evacuation. The sudden strobe flash might disrupt a surgical operation in progress which could be catastrophic. For such facilities, the requirements for visual and audible alarm may be modified to suit the norm of industry-accepted practices.

5.4 EMERGENCY ALARM IN ACCESSIBLE TOILETS

5.4.1 This section sets out the requirements for provision of emergency alarm system in accessible toilets.

MANDATORY SECTION

5.4.2 Performance Objectives

The push buttons of the emergency alarm shall be appropriately located and conveniently accessible to all users. The alarm when activated shall emit audible or visible alarm signal which shall be readily noticeable for summoning assistance for the person in the accessible toilet.

5.4.3 Obligatory Design Requirements

Waterproof Push Button

(a) An emergency alarm shall be equipped with a weatherproof push button for activating the alarm.

Positioning of Emergency Push Button / Alarm

(b) The emergency push button shall be installed below the vertical grab rail inside the W.C. cubicle adjacent to the water closet at a height between 600mm to 650mm above the finished floor level. A notice “**Emergency Call**” in both English, Chinese and Braille shall be fitted next to the emergency push button. The alarm shall be installed outside the toilet or a buzzer shall be fitted in the caretaker’s office (see **Figure 24**).

BEST PRACTICE SECTION

5.4.4 Design Considerations

(a) An emergency push button should be easily operated and be provided in any individual accessible toilet compartment or a water closet cubicle designed for the persons with a disability to summon assistance at seated position or on the floor when the person has fallen accidentally. The call button, sometimes equipped with a pull cord of a length between 700 mm to 750 mm should be suitably positioned and reachable not more than 300 mm from floor level.

(b) In addition to a position outside the compartment or cubicle, the emergency alarm should be connected to a 24-hours manned caretaker’s office.

5.5 PUBLIC TELEPHONES

5.5.1 This section sets out the requirements for telephones intended to be used by the public.

5.5.2 Public telephones should be accessible by all users, including wheelchair users and persons with visual or hearing impairment.

BEST PRACTICE SECTION

5.5.3 Design Considerations

- (a) Telephones should be fixed at an appropriate height which is within easy reach and easy to use, to enable all users, including persons with a disability to make full use of them.
- (b) Other helpful features which should be provided include support rails; adequate lighting; seats; big buttons; lamp signaling; amplifying handset; inductive coupler; speakerphone; and digit 5 indicator.
- (c) The provision of a text phone enables person with hearing impairment to make calls.

5.5.4 Recommended Design Requirements

Keypad

- (a) The keypad of a public payphone, if provided with mechanical keypad, should have a digit 5 indicator (see **Figure 41**).

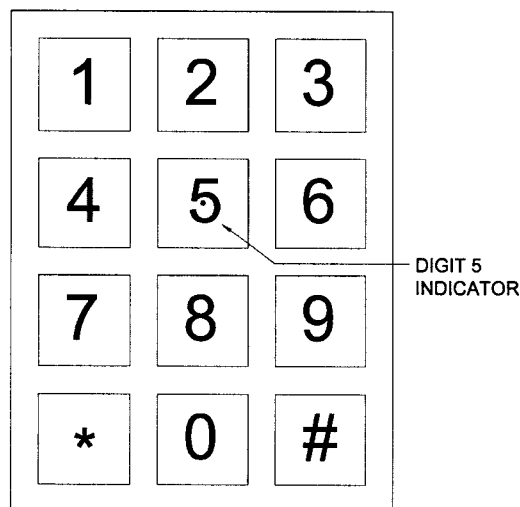

Figure 41 – Digit 5 Indicator

5.5.4 Recommended Design Requirements (Cont'd)

Telephone for Persons with Ambulant Disabilities and Wheelchair Users

- (b) At least one in a group of two or more payphones should be designed for access by persons with a disability and in compliance with the following: -
- (i) the approach to the accessible payphone should be free of obstacles;
 - (ii) the accessible payphone should not be placed on a stepped base unless a ramp in compliance with **Section 4.2** is provided;
 - (iii) the cord length of the accessible payphone should not be less than 750 mm;
 - (iv) to facilitate wheelchair users, all operable parts including the coin slot of the accessible payphone should not be positioned higher than 1200 mm above the finished floor level;
 - (v) if there is an enclosure for the accessible payphone, the enclosure should begin no more than 650 mm from the finished floor level to prevent it from being a hazard to persons with visual impairment;
 - (vi) there should be a clear floor space of at least 750 mm by 1200 mm in front of the accessible payphone to allow either a forward or parallel approach by a wheelchair user;
 - (vii) if a parallel approach is adopted, the enclosure sides, if there is an enclosure, should not extend more than 250 mm in front of the face of the accessible payphone;
 - (viii) If a forward approach is adopted, the enclosure, if any, should have a clear width of at least 800 mm to provide wheelchair access; shelves or other obstructions should not extend more than 400 mm from the face of the accessible payphone; and there should be a space of 750 mm wide by 650 mm high by 430 mm deep for the footplate of a wheelchair;
 - (ix) if the accessible payphone is provided in an enclosed booth, the door of the booth should open outwards and have a clear width of not less than 800 mm between the open door and the opposite jamb or the other leaf; and
 - (x) if the accessible payphones are provided in a booth without door, the entrance to the booth should not be less than 800 mm wide.
- (c) Grab rails should be installed on each side of the accessible payphone booth to enable those on crutches or with canes to maintain balance while using the accessible payphone. Otherwise, there should be a space of not less than 900 mm in width in the phone booth for persons with a disability to enter with their crutches and canes.

5.5.4 Recommended Design Requirements (Cont'd)

Telephone for Persons with Ambulant Disabilities and Wheelchair Users (Cont'd)

- (d) A fold-down seat should be provided in accessible booths for the convenience of persons with ambulant disabilities.

Telephone for Persons with Visual Impairment

- (e) At least one in a group of two or more payphones should be designed for access by persons with visual impairment. Such payphone should be provided with a mechanical keypad with the digit 5 indicator and a detection system that activates a recorded sound message, giving explanations on the operational procedures to the users, as the handset is picked up.
- (f) Phone cards for payphones should bear a “notch” on the left bottom to aid orientation for persons with visual impairment.

Telephone for Persons with Hearing Impairment

- (g) At least one in a group of two or more payphones should be provided with amplifying handset or receiver with inductive coupler. If a payphone is equipped with the latter, it should be identified by the international symbol of access for persons with hearing impairment (**Figure 30**).

Telephone for Persons With Speech Impairment

- (h) At least one in a group of two or more payphones should be capable of handling written messages for access by persons with speech impairment.

5.6 ASSISTIVE LISTENING SYSTEMS

5.6.1 An assistive listening system is a system which enables sound signals to be transmitted to persons with hearing impairment without interference from background noise or excessive reverberation

MANDATORY SECTION

5.6.2 Performance Objectives

In order to obtain the full benefit of attending public performances or taking part in discussions, a person with hearing impairment needs to receive a signal that is amplified in both volume and signal to noise ratio.

5.6.3 Obligatory Design Requirements

- (a) An assistive listening system such as an induction loop system or an infrared system shall be provided in:
 - (i) at least one of the information/service counters, if any, for various categories of buildings as specified in **Table 2**;
 - (ii) the community hall, if any, of such a building; and
 - (iii) the auditorium, if any, of such a building.

BEST PRACTICE SECTION

5.6.4 Design Considerations

- (a) An assistive listening system amplifies audible communication, and can be used by persons with hearing aids. It does not interfere with the listening of people with normal hearing.
- (b) The three assistive listening systems commonly used to provide this enhanced level of sound are induction loop, infrared and radio frequency systems. A decision on which system to use will depend on a number of factors, such as the size and use of the space, external interferences and building materials used.
- (c) Special-purpose receivers are required by infrared and radio frequency systems while hearing aids equipped with a T-switch are capable of receiving the signal from an induction loop system. Designers should seek expert advice concerning the most appropriate system for their purposes.

5.6.5 Recommended Design Requirements

Coverage

- (a) The assistive listening system must be available to cover not less than 70% of the floor area of the room or space served by the system. If a system requiring the use of receivers or the like is adopted, a minimum of 2 receivers should be provided. The number of receivers provided must be not less than 1 for every 50 persons (or part thereof).

5.7 LIFTS

5.7.1 Lift provides means of vertical transportation to any user of the building to move from one floor to another.

MANDATORY SECTION

5.7.2 Performance Objectives

Where a lift is provided, appropriate provision shall be made for all people to travel vertically within the buildings conveniently and independently to other storeys and to make use of all relevant facilities.

5.7.3 Obligatory Design Requirements

- (a) Every floor of a building shall be accessible by at least one passenger lift which shall fully comply with all the obligatory design requirements as stipulated in this section and have direct access to main lift lobby.
- (b) All other passenger lifts in the building must comply with **Clauses 5.7.3 (e), (f), (g), (h), (i), (j), (k), (l), (m) and (n)**.

Lift Cars (See Figure 42)

- (c) A lift shall have minimum internal car dimensions of 1200 mm x 1100 mm wide, with a minimum clear entrance width of 850 mm, and shall have handrails extending to within 150 mm of the corners at the rear and sides of the car. The top of the gripping surface of the handrails shall be at a height of 850 mm – 950 mm, with a space of 30 mm - 50 mm between the handrails and wall.
- (d) Where there are more than three lifts in a building, access shall be provided to every floor by at least one lift having minimum internal car dimensions of 1500 mm x 1400 mm (either wide or deep) with a minimum clear entrance width of 850 mm.

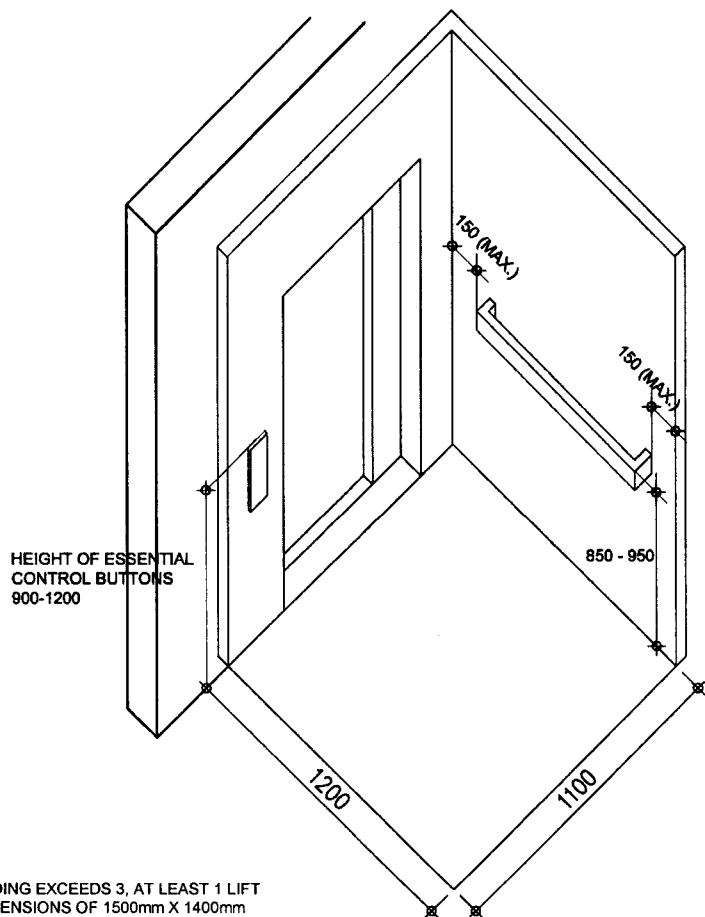
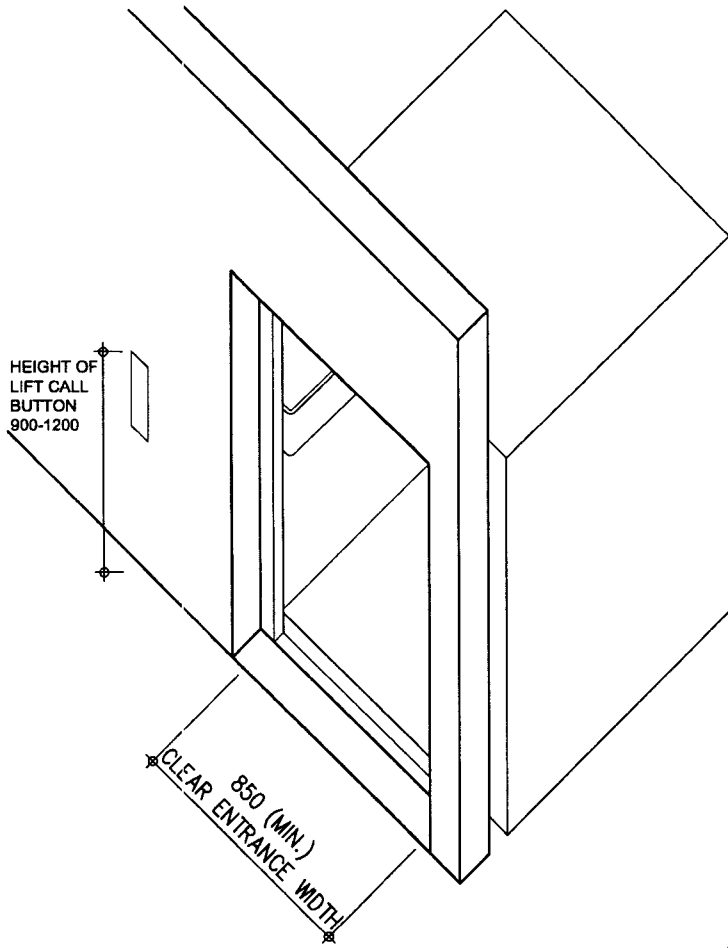

NOTE: WHERE THE NUMBER OF LIFTS IN A BUILDING EXCEEDS 3, AT LEAST 1 LIFT SHALL HAVE MINIMUM INTERNAL CAR DIMENSIONS OF 1500mm X 1400mm

***ALL DIMENSIONS ARE IN mm**
Figure 42 – Accessible Lift

5.7.3 Obligatory Design Requirements (Cont'd)

Lift Doors

- (e) Lift car doors and landing doors shall be of the horizontally sliding type, power-operated and automatically controlled.
- (f) A detection device shall be provided to re-open the lift doors in the event of hitting any obstacle, and the detection device shall be positioned at a height of between 500 mm to 600 mm above the floor of the car.
- (g) An audible signal shall be provided to signify the closing of the doors to alert persons.

Lift Control Buttons

- (h) Essential lift control buttons including floor numbering buttons, emergency alarm push button and door opening push button in the lift car and the lift call buttons at the lift halls shall not be less than 900 mm and not more than 1200 mm above the floor of the car or the finished floor level of the lift hall. Provision of secondary control panel for over-spilled floor numbering buttons is always acceptable.
- (i) All lift control buttons shall have a minimum dimension of 20 mm (see **Figure 43**).
- (j) Braille and tactile markings shall be placed either on or to the left of the control buttons. Such markings shall be in Arabic numerals and/or symbols. Tactile markings shall have a minimum dimension of 15 mm high and be raised 1 mm minimum.
- (k) The tactile marking of the push buttons for the main entrance floor shall be identified with a symbol in a star shape (see **Figure 43**).
- (l) The emergency alarm push button shall be in a tactile bell shape (see **Figure 43**).

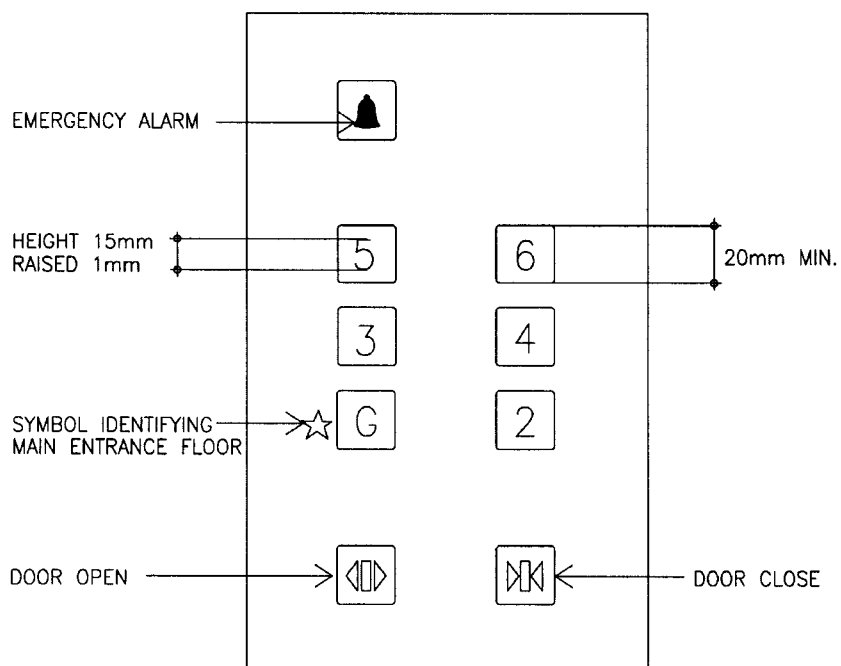
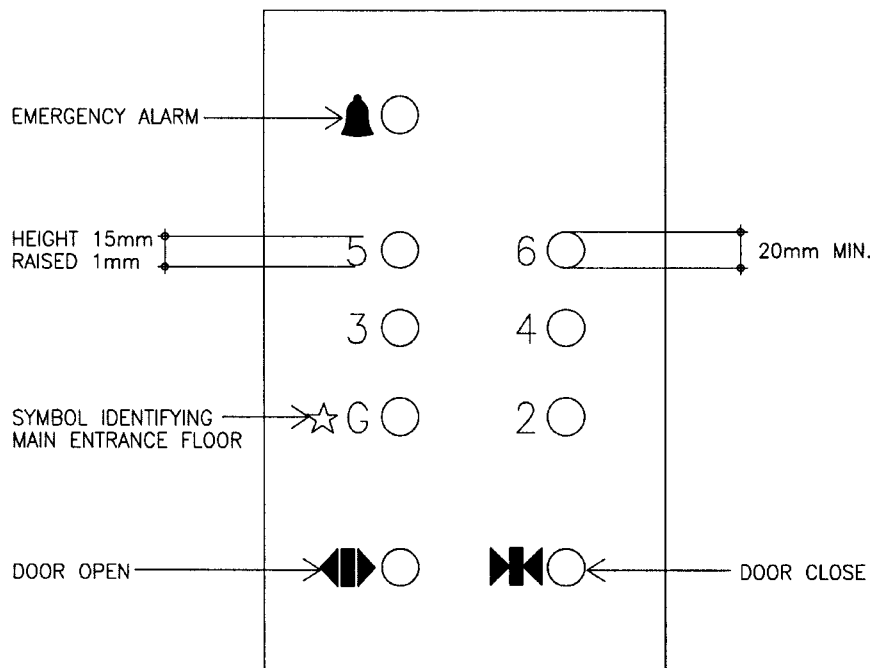

Figure 43 – Tactile Graphic for Lift Control Buttons

5.7.3 Obligatory Design Requirements (Cont'd)

Emergency Call Button in Lifts

- (m) An emergency alarm push button together with a buzzer, an indication light for acknowledgement and an intercom shall be provided in each lift car and be connected to the building management office or the caretaker's office. The building management office or the caretaker's office shall be equipped with a buzzer, indication light(s) (one for each lift) and an intercom connected to the lift car(s).
- (n) The indication light for acknowledgement shall be in the form of a blinking light adjacent to the intercom speaker and a notice "When light blinks, it indicates your emergency call has already been received. Please be patient and wait for the rescue." in English and Chinese shall be provided next to the blinking light. This system shall be powered by an emergency electricity supply system in the event of power failure.

BEST PRACTICE SECTION

5.7.4 Design Considerations

- (a) Lifts can help to provide access to storeys above or below the main entrance level. If designed appropriately, lifts are the most convenient form of vertical access for persons with a disability. However, given the space constraints in some buildings, it may not always be possible to install the type and size of passenger lift that would be suitable for use by all, and other options may need to be considered to provide for users with ambulant impairments.
- (b) Lift controls should be installed at the position which is within reach of all users including wheelchair users.
- (c) A wheelchair user needs sufficient space and time to enter and leave a passenger lift, particularly when sharing it with other people. Lift sizes should therefore be chosen to suit the anticipated frequency of use of the building and the needs of persons with a disability.
- (d) Lift door systems should be designed to allow adequate time for passage of persons with a disability and the elderly.

5.7.4 Design Considerations (Cont'd)

- (e) The use of visually and acoustically reflective wall surfaces can cause discomfort for persons with visual and hearing impairment.
- (f) For lifts of the size that does not allow a wheelchair user to turn around within the lift car, mirror should be installed with the bottom edge to be set at 900 mm above the floor level in the lift car to facilitate a wheelchair user in reversing and to see which level the lift has reached.
- (g) Where planning allows, lift cars may be provided with opposing doors to allow a wheelchair user to leave without having to reverse.

5.7.5 Recommended Design Requirements

Lift Control Buttons

- (a) The graphics for tactile markings for open-door and close-door push buttons, emergency alarm button, and main entrance level are shown in **Figure 43** for reference.
- (b) Call button panels should be provided at both sides of door openings.

Keypad design

- (c) In cases where difficulties are encountered to fully comply with the obligatory requirements of installation of lift control buttons in high-rise buildings, keypad control device in conjunction with a conventional lift control panels in lifts for persons with a disability should be provided. Proposed standardized positions of buttons for keypad control device are shown in **Figure 44** for reference.

The keypad should: -

- (i) have control buttons of minimum dimension of 20 mm;
- (ii) have Braille and tactile markings following the standard as stipulated in **Clause 5.7.3(j) and (l)**;
- (iii) be installed between 900mm to 1200mm from finished floor level of the lift car;
- (iv) have adequate luminous contrast between the tactile markings on the buttons and the background;
- (v) have voice announcement and visual indication of the floors registered; and

5.7.5 Recommended Design Requirements (Cont'd)

Keypad design (Cont'd)

- (vi) have instruction for the keypad control panel in the form of Cantonese Braille or voice announcement beside the panel.

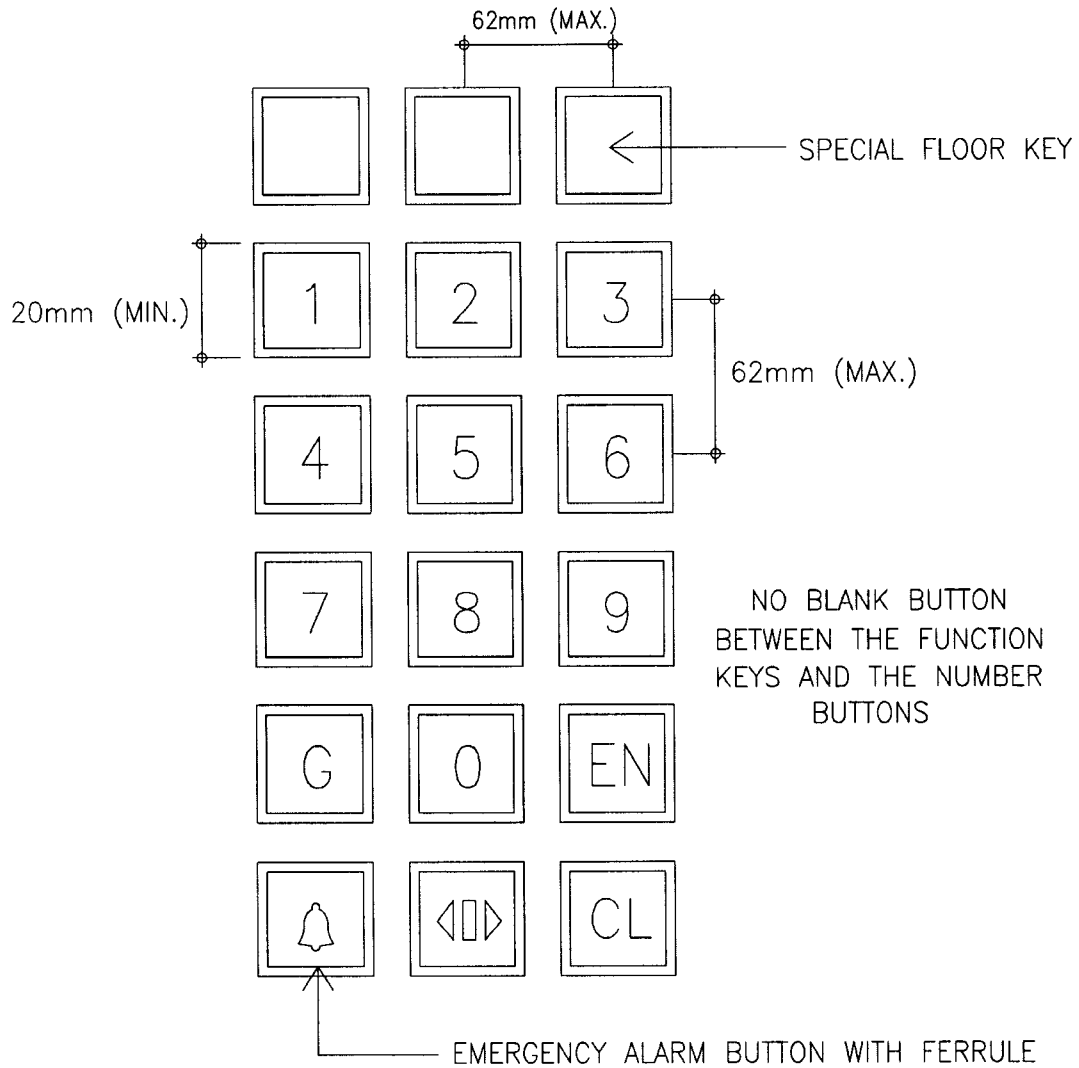

NOTE: BRAILLE AND TACTILE MARKINGS AND CHINESE CHARACTERS ARE NOT SHOWN

Figure 44 – Proposed Standardised Position of Buttons for Keypad Control Device

5.7.5 Recommended Design Requirements (Cont'd)

Illumination Level

- (d) The level of illumination at the car controls, platform, car threshold, landing sill and lift landing shall be 150 lux minimum.

Wheelchair Turning Space

- (e) An unobstructed wheelchair turning space of 1500 mm x 1500 mm should be provided in front of accessible lift car door.

Lift Doors

- (f) The minimum time for lift doors to remain fully open at a landing should be 3 seconds.

5.8 INDICATION AND NOTIFICATION FOR LIFTS COMPLYING WITH SECTION 5.7

5.8.1 The requirements for indication and notification to be provided in respect of accessible lifts are set out in this section.

MANDATORY SECTION

5.8.2 Performance Objectives

Indication and notification shall be provided to give audible and visual information to enable all persons with a disability to call and use the lift facilities conveniently and independently.

5.8.3 Obligatory Design Requirements

Lift Entrances / Halls

- (a) An illuminated visual indicator and an audible signal shall be provided at the lift entrance to indicate the arrival of the lift car and its direction of travel. The audible signal shall sound once for UP direction and twice for DOWN direction, and shall be activated before the arrival of the lift. The audible signal can be broadcasted from a device in the lift car as an alternative provided it can be heard from the lift lobby.
- (b) Tactile and Braille floor designations shall be provided on the jambs on both sides of each lift entrance, by means of Arabic numerals, minimum 60 mm high, raised 1 mm, and at 1200 mm above the finished floor level.

Lift Cars

- (c) Illuminated visual indicators shall be provided to indicate the direction of travel and the position of the car. Characters on the position indicator shall have a minimum height of 50 mm.
- (d) An audio indication of the stopping floor shall be provided in Cantonese, English and Putonghua.

Identification of Accessible Lifts in Lift Lobbies

- (e) If a building contains some lifts that do not comply with this Manual, then each of those lifts that do comply shall be identified at each landing served, by not less than one international symbol for accessibility.

5.8.3 Obligatory Design Requirements (Cont'd)

Identification of Lifts in Lift Lobbies (Cont'd)

- (f) If all the lifts in a building comply with this Manual (including a building with only one lift), then at least one international symbol for accessibility shall be provided at each lift lobby on the entrance levels of the building.

BEST PRACTICE SECTION

5.8.4 Design Considerations

- (a) Signs indicating the location of an accessible lift should be clearly visible from the main entrance of the building. Additionally, a sign identifying the floor reached should be provided on each landing in a location that can be easily seen from the lift and is designed in luminous contrasts with its surroundings.

5.8.5 Recommended Design Requirements

Tactile Warning

- (a) Tactile warning tiles should be placed in front of the lift door of the accessible lift complying with **Sections 5.7 and 5.8** at each landing for ease of identification by persons with visual impairment.

Control

- (b) A separate call button for the accessible lift complying with **Sections 5.7 and 5.8** should be installed on each floor to ensure that the accessible lift will stop at the called floor. Priority of attendance to call for the accessible lift should be given to this button.

5.9 ESCALATORS / PASSENGER CONVEYORS

5.9.1 Escalators and passenger conveyors provide means of vertical and horizontal transportation within a building respectively.

MANDATORY SECTION

5.9.2 Performance Objectives

Escalators or passenger conveyors are not considered part of a barrier-free route of travel. However, adequate warning or guarding shall be provided alongside and at each end of the escalators / passenger conveyors for the safety of persons with visual impairment.

5.9.3 Obligatory Design Requirements

Tactile Warning

- (a) Tactile warning strips shall be provided at both bottom and top ends of an escalator. The provision of tactile warning strips is illustrated in **Figure 36**.
- (b) Tactile warning strips shall be provided at both ends of a passenger conveyor. The provision of tactile warning strips is illustrated in **Figure 36**.

BEST PRACTICE SECTION

5.9.4 Design Considerations

- (a) Escalator can be a useful addition to stair and lift where significant height difference has to be negotiated, but it should be designed with slower speed for the safety use by persons with visual impairment and the elderly.
- (b) The angle of inclination of escalator should not exceed 30°.
- (c) Adequate distance for horizontal movement of steps is required at the top and bottom of escalator to ensure that passengers – especially those leaving the escalator – have adequate space and time to board and alight safely.

5.9.4 Design Considerations (Cont'd)

- (d) Step edge should be clearly defined with colour in sufficient luminous contrast with the background, e.g. yellow colour against dark grey steps.
- (e) Moving handrail should be in luminous contrast with the background.
- (f) Passenger conveyer may be used when there is substantial traveling distance between pedestrian entrance and vehicular access point, e.g. in an airport terminal. It is mechanically similar to escalator which may be level or inclined.
- (g) The same principles of luminous contrast as for escalator should apply to passenger conveyer.
- (h) There must always be an alternative pedestrian route provided.

5.9.5 Recommended Design Requirements

Audio Indicator

- (a) For escalator and passenger conveyer, clear signal or indication for going up / down or moving forward should be provided on both ends, e.g. consistent clear sound or signals.

Alternative Access

- (b) Where there is an accessible lift that provides alternative access route for persons with a disability, it should be near to, and clearly shown by a sign posted at the entry to the escalator.

5.10 VERTICAL LIFTING PLATFORMS

5.10.1 A vertical lifting platform is a mechanical lift with a platform and walls which provides vertical circulation between two levels.

5.10.2 A vertical lifting platform shall be designed to facilitate persons with ambulant disabilities and wheelchair users for the vertical transportation from one level to another in a building.

BEST PRACTICE SECTION

5.10.3 Design Considerations

- (a) Installation of vertical lifting platform is necessary if no other means of vertical transportation is available when the presence of persons with a disability can be envisaged.
- (b) It provides an accessible route to a performing area.
- (c) It provides access to equipment control rooms and projection booths.
- (d) Clear instructions for use and emergency alarm should be provided inside the lifting platform.

5.10.4 Recommended Design Requirements

- (a) Where it is impractical to provide a passenger lift or a ramp, a self-operated vertical lifting platform should be considered as a reasonable alternative for vertical circulation for wheelchair users, the vertical lifting platform should have the following provisions (see **Figure 45**): -

Door

- (i) minimum clear entrance width of 900 mm;
- (ii) Single door or 2-door design;

Platform size

- (iii) minimum size of 1100 mm (wide) x 1400 mm(deep);

5.10.4 Recommended Design Requirements (Cont'd)

(a) (Cont'd)

Safety Barrier

- (iv) provision of safety barriers of not less than 1100mm in height;
- (v) provision of a flip-up ramp if a door is not provided, to act as a safety barrier and serves as an access ramp for wheelchair users;

Control

- (vi) lift buttons should comply with **Clause 5.7.3 (h) and (i)**;
- (vii) automatic homing device should be installed so that in the event of a power failure, the platform lift will descend to the entrance level;

Grab bars

- (viii) grab bars complying with **Clause 4.5.3 (f)** should be placed at a height of 900mm from the finished floor level and be fixed on both sides and at the rear of the lift car;

Maximum Travel and Loading

- (ix) the maximum travel should be 4000 mm;
- (x) the rated load of the lifting platform should not exceed 500 kg; and

Sign

- (xi) A sign to indicate the rated load should be provided at a prominent position next to the lift control buttons inside the lift; and

Landing

- (xii) The landings to a vertical lifting platforms at the 2 access levels should be in opposite directions so as to eliminate the need for the wheelchair to back-out.

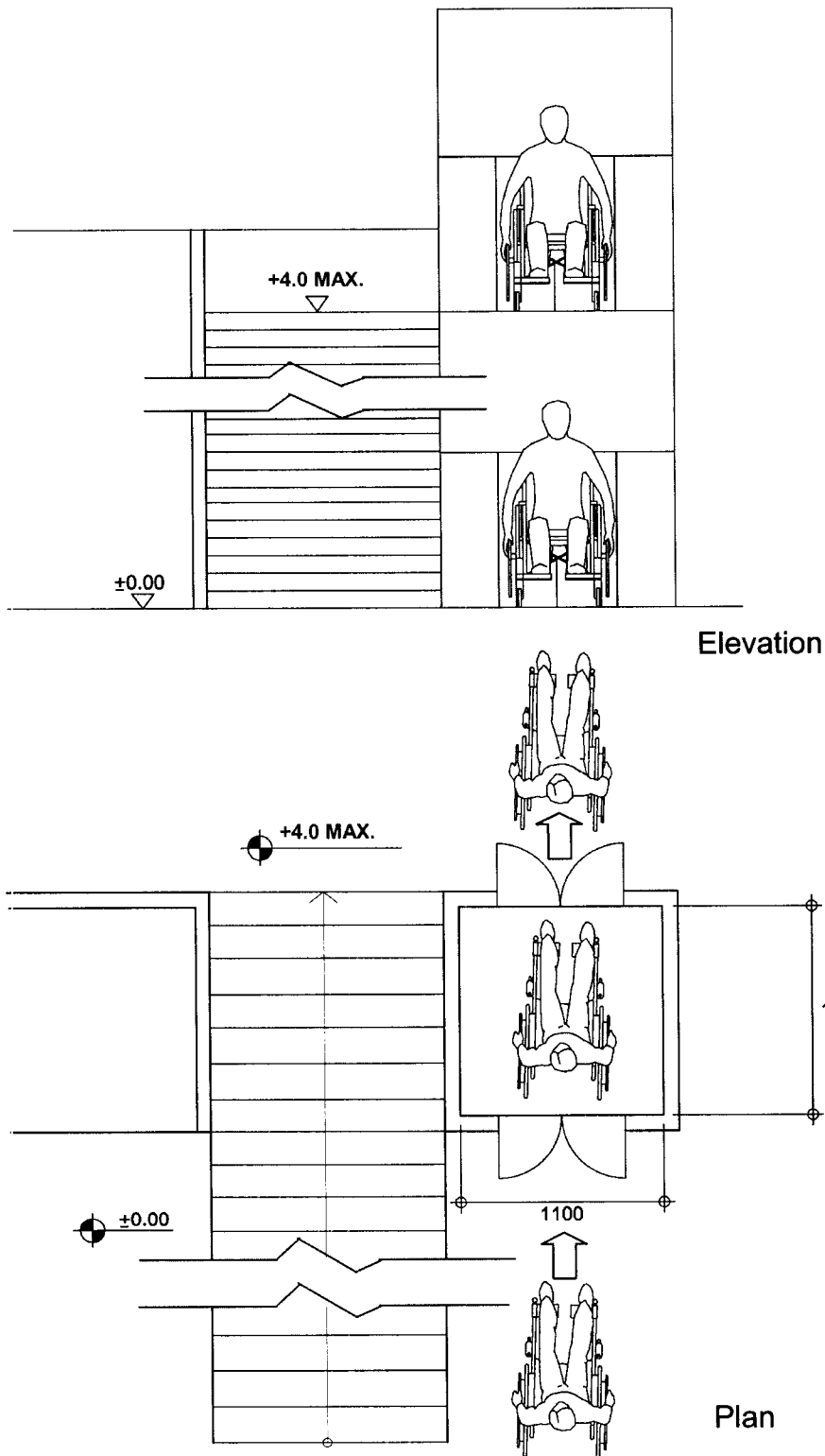

*ALL DIMENSIONS ARE IN mm

Figure 45 – Vertical Lifting Platform

5.11 REMOTE SIGNAGE SYSTEMS

5.11.1 A remote signage system carries and transmits a voice message to the users in the form of a talking sign. The system shall provide audible information to persons with visual impairment who are equipped with proper receivers.

BEST PRACTICE SECTION

5.11.2 Design Considerations

- (a) A remote signage system normally consists of short audio signals sent by invisible infrared light beams from permanently installed transmitters to a hand-held receiver that decodes the signal and delivers the voice message through its speaker or headset.
- (b) With the hand-held receiver, persons with visual impairment can scan the environment and locate his relative position. It can work effectively in both interior and exterior applications for landmark identification and way-finding.
- (c) The system promotes more confident and independent travel throughout all major common areas.

5.11.3 Recommended Design Requirements

- (a) A remote directional signage system which transmits a voice message by means of infrared or the like detectable by a proper receiver should be provided to facilitate access and movement of persons with visual impairment.

5.12 DRINKING FOUNTAINS

5.12.1 This section sets out the requirements for provision of drinking fountains. A drinking fountain is a primary means for providing the public with sanitary water.

BEST PRACTICE SECTION

5.12.2 Design Considerations

- (a) The design and provision of drinking fountains should take into account the envisaged use of persons with a disability.
- (b) The operable controls and direction of water flow should be designed and installed in a manner to facilitate the use by persons with a disability.
- (c) Facilities for wheelchair users call for extra consideration in relation to access and manoeuvring space.

5.12.3 Recommended Design Requirements

Provision

- (a) Where drinking fountains are provided, at least one of the drinking fountains on a given floor should have a design complying with this section.

Spout

- (b) The fountain spout should: -
 - (i) have an opening located between 750 mm to 900 mm from the floor or ground surface;
 - (ii) be located near to the front of the unit;
 - (iii) direct the water flow in a trajectory that is parallel or nearly parallel to the front of the unit; and
 - (iv) provide a flow of water at least 100 mm high to allow for the insertion of a cup or glass.
- (c) Automatic controls or controls with handles of the lever type operable with a closed fist should be provided.

5.12.3 Recommended Design Requirements (Cont'd)

Control

- (d) Controls should: -
 - (i) be at or near to the front of the fountain;
 - (ii) be operable with one hand; and
 - (iii) require no tight grasping, pinching, or twisting of the wrist.

Spatial Arrangement

- (e) The spatial arrangement should allow for the provision of: -
 - (i) a clear floor space of at least 750 mm x 1200 mm;
 - (ii) a clear knee space of at least 750 mm wide, 200 mm deep and 680 mm high between the bottom of the apron and the floor or ground; and
 - (iii) a toe space not less than 750 mm wide, 230 mm deep and 230 mm high.
- (f) All wall-mounted drinking fountains should be placed in an alcove to eliminate the hazard of collision to persons with visual impairment.
- (g) A wall guard should be installed to protect a drinking fountain that extends into a corridor and has an open space underneath.

Dimensions relating to the design of drinking fountains are shown in **Figure 46**.

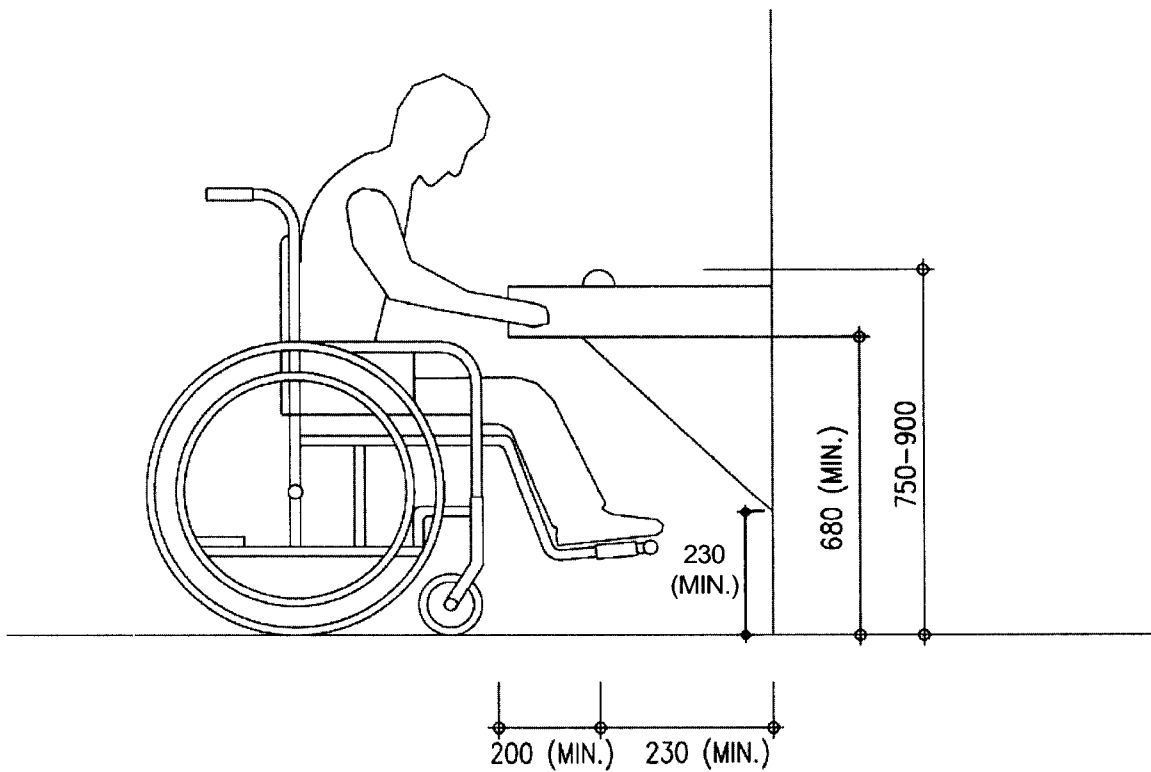
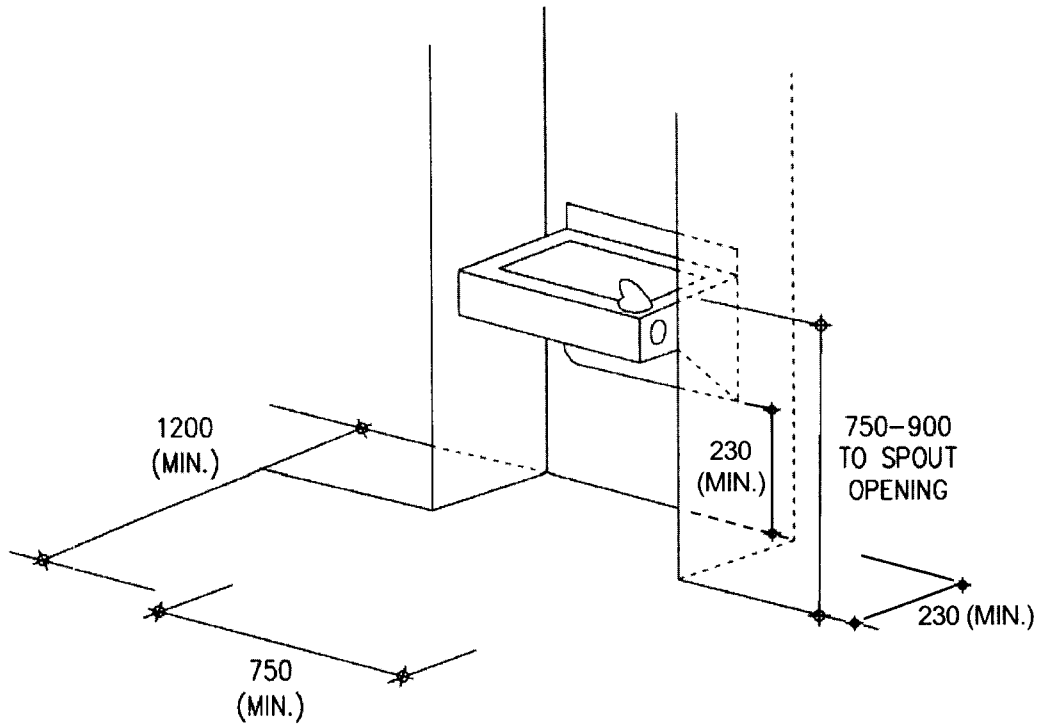

SPOUT HEIGHT AND KNEE CLEARANCE

*ALL DIMENSIONS ARE IN mm

Figure 46 – Built-in Drinking Fountain

CHAPTER 6

DESIGN GUIDELINES FOR THE ELDERLY AND ELDERLY WITH FRAILITY

6.1 GENERAL

Many aspects of design for persons with a disability are already covered in the Mandatory Sections of this Design Manual and can be usefully applied to the design of both interiors and exteriors of all structures and buildings to make them more friendly to the elderly. The guidelines set out in this Chapter aim to provide additional design recommendations for building a more comfortable, healthy and safe built-environment for older persons.

“Ageing-in-Place” is a universal concept accepted as fundamental to new housing design, the creation of elderly-friendly homes and environment will allow the elderly to enjoy life with autonomy which is essential in achieving the goal of healthy ageing.

Ageing is a gradual process. The level of ability of a person declines in a progressive manner as ageing progresses. To minimize the potential risks leading to injuries or accidents, the following design guidelines are recommended in consideration of the common habitual actions as well as the declining abilities of many older persons.

6.2 DESIGN CONSIDERATIONS

	Common Habitual Actions of the Elderly	Recommended Design Guidelines
6.2.1	The elderly may be unstable in their gait and unable to recognise changes in level of floor surfaces.	<p>Barrier free access should be without steps, thresholds, small ramps or kerbs, wherever possible. Where changes in level are unavoidable, handrails or grab bars should be provided, no matter how slight the level change may seem.</p> <p>Steps and staircases should be designed with wider treads and lower risers.</p> <p>Floor surfaces should comply with Section 4.1. Slip-resistant floor finishes should be used, shiny and reflective floors such as marble, glazed tiles and the like should be avoided.</p>

6.2 DESIGN CONSIDERATIONS (Cont'd)

	Common Habitual Actions of the Elderly	Recommended Design Guidelines
6.2.1 (Cont'd)		<p>Escalators should be designed with slower speed.</p> <p>Open jointed pavers or aeration paver blocks with uneven or very rough surface should be avoided at external open spaces.</p>
6.2.2	<p>The elderly may be unable to see clearly and may have problems in accommodating dramatic changes of lighting levels.</p>	<p>Where changes in level are unavoidable, the floor and wall surfaces along the level difference shall be in luminous contrast.</p> <p>All common areas of a building should have an illumination level of not less than 120 lux measured at the finished floor level, and uniformity of illumination level should be maintained for any space.</p> <p>Alternative or stand-by light sources should be provided to illuminate any space in case of power failure.</p> <p>Double-switching system should be considered. Switches should be installed near to bedside to avoid needing to cross the room in the dark.</p> <p>Consideration should be given to ensure gradual transition of lighting levels from one place to another.</p> <p>The use of natural lighting or ambient artificial white light should be encouraged.</p> <p>The use of wall-mounted light or peripheral lighting from floor lamps are superior to a central ceiling source as the formation of shadows can be avoided.</p> <p>Bare light bulbs producing glare which would cause painful to the aging eyes should be avoided.</p>

6.2 DESIGN CONSIDERATIONS (Cont'd)

	Common Habitual Actions of the Elderly	Recommended Design Guidelines
6.2.2 (Cont'd)		<p>All interior spaces should be lit at a consistent and even level, from floor to ceiling and from wall to wall. High contrast between shadow and light creating confusion and disorienting patterns should be avoided.</p> <p>As the lens thickens and yellows with age, it becomes less sensitive to colours having shorter wavelengths (blues, greens and violets). Warm colours with longer wavelengths (reds, oranges and yellows) are easier to differentiate. The use of the bright primary colour as contrast or highlight is therefore recommended.</p> <p>Monotone colour should be avoided.</p> <p>The colour combination of signage - yellow figure on black background or white figure on blue background is recommended.</p>
6.2.3	The elderly would have decreased stamina.	<p>Resting places such as fold-down seats on stair landings or in long corridors should be provided.</p> <p>Resting places in external recreation spaces should be adequately provided.</p>
6.2.4	The elderly may have difficulties in way finding.	<p>Different colours should be used for different floor levels, zonings or areas of different functional purposes.</p> <p>Different floor surfaces should be considered for tactile cues for navigation.</p> <p>Auditory input at lift helping the elderly to locate themselves should be used.</p> <p>Control panel or switch at the lift lobby should be located at 1050 mm above the finished floor level. It should be easily operated and have a minimum luminous contrast of 30%.</p>

6.2 DESIGN CONSIDERATIONS (Cont'd)

	Common Habitual Actions of the Elderly	Recommended Design Guidelines
6.2.5	The elderly may fall due to bending, stooping and stretching.	<p>Switches and controls should be installed at reachable heights preferably at the same level as door handles.</p> <p>Handrails to corridors, steps and staircases should be lowered to a height between 810 mm and 900mm from the finished floor level to the top of the handrails.</p> <p>Cupboards should not be installed at high levels. Overhead cabinets should be avoided.</p> <p>Outdoor drying rack systems with laundry poles should be avoided.</p>
6.2.6	The elderly may be weak in gripping, and may have difficulties in turning and manipulating taps, switches, door handles and the like.	<p>Handrails should be of materials such as timber or plastic-coated surfaces for easier grip.</p> <p>Lever-type controls and handles with limited grip should be used. Knob handles, push operated and self-closing type faucet controls should be avoided (see Figure 47).</p>
6.2.7	The elderly may have difficulties in pushing open heavy doors.	Sliding door is a good choice. Should door closing devices be used, they should be designed to allow external and internal doors to be opened with horizontal forces of not more than 28N and 18N respectively.
6.2.8	The elderly require safety design provisions for bathrooms and toilets.	<p>Doors of bathrooms and toilets should open outward or both ways. Locks and latches should be of larger sizes and be able to open from outside with a coin.</p> <p>Emergency alarm system should be installed. Emergency call bell shall comply with Section 5.4. Should pull-cord be installed, they must be extended to floor-level.</p>

6.2 DESIGN CONSIDERATIONS (Cont'd)

	Common Habitual Actions of the Elderly	Recommended Design Guidelines
6.2.8 (Cont'd)		<p>Bathtub should have either built-in seat at the head end or attachable portable seat that fastens securely to the tub when needed.</p> <p>Showers, other than roll-in types, should be of size 1500 mm x 900mm minimum with a folding seat to allow transfer.</p> <p>Doorways should be wide enough to allow a wheelchair to pass through and space of bathrooms and toilets should be adequate for turning and transfer.</p> <p>Grab bars should be installed and to comply with Sections 4.8 and 4.9.</p>
6.2.9	The elderly require comfortable and healthy built-environment.	<p>Sound-absorbing materials should be used for floors and walls to avoid echoes.</p> <p>Non-glare or low gloss finishes on floors, matt paint or textured wallpaper on walls should be considered to help reduce glare. Glass or reflective material should be avoided.</p> <p>Large windows should be avoided at the end of long and dark corridors.</p> <p>Cross ventilation should be optimized in common areas such as corridors and lift lobbies.</p> <p>Recreational facilities such as shelters and benches, pavilions and tai-chi areas with safety flooring system should be provided in external open spaces.</p>

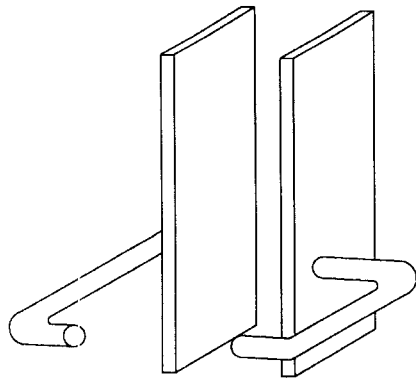

LEVER HANDLES

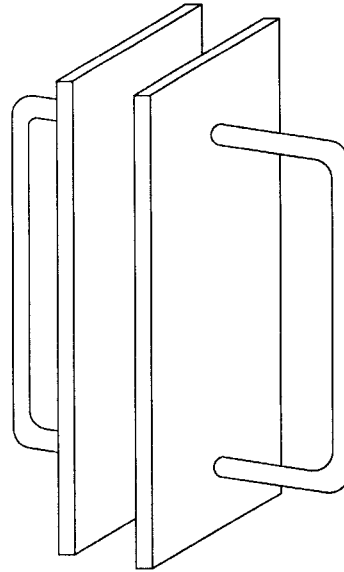

**PUSH/PULL PLATE DOOR
PULL**

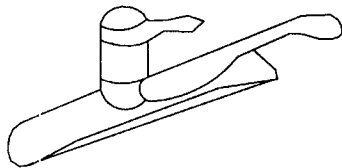

**LONG LEVER HANDLE
(RECOMMENDED)**

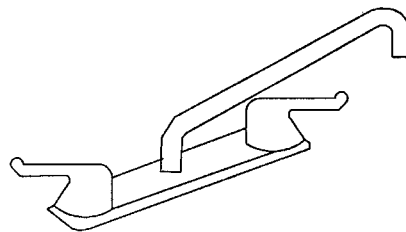

**SINGLE LEVER HANDLE
(RECOMMENDED)**

Figure 47 – Examples of Door Handles and Faucets

Appendix A

Anthropometrics

APPENDIX A

ANTHROPOMETRICS (All dimensions are in mm)

A.1 Objective:

This Appendix contains dimensional data which can be used for guidance when designing facilities and equipment for use by persons with a disability.

A.2 Considerations:

The dimensions of the individual human being vary with time and from one person to another. In addition, the average dimensions vary from one country to another. When carrying out detailed design, consideration should be given to size variation between males and females as well as between different ages.

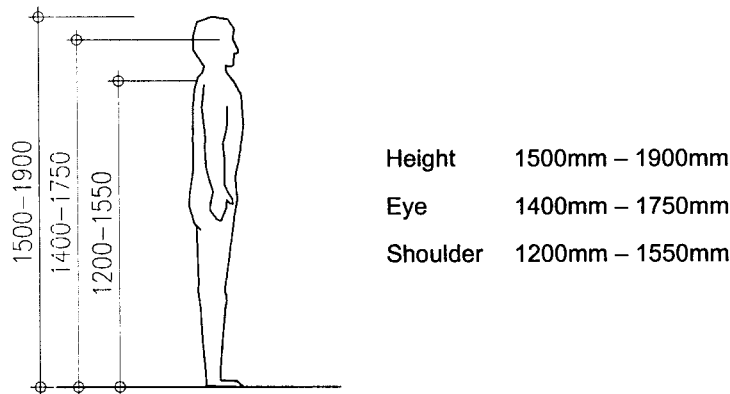

Figure A1 - Dimensional Data of an Average Person

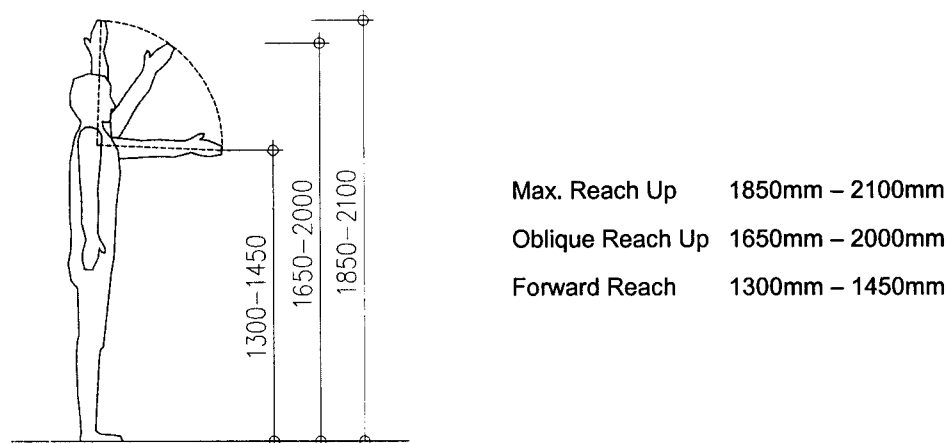

Figure A2 - Reaching Zones of an Average Person

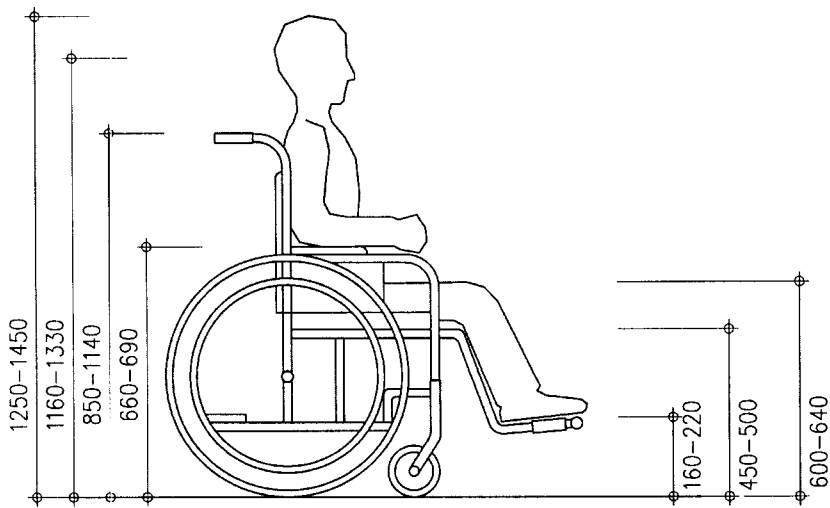

Figure A3 - Dimensional Data of a Wheelchair User

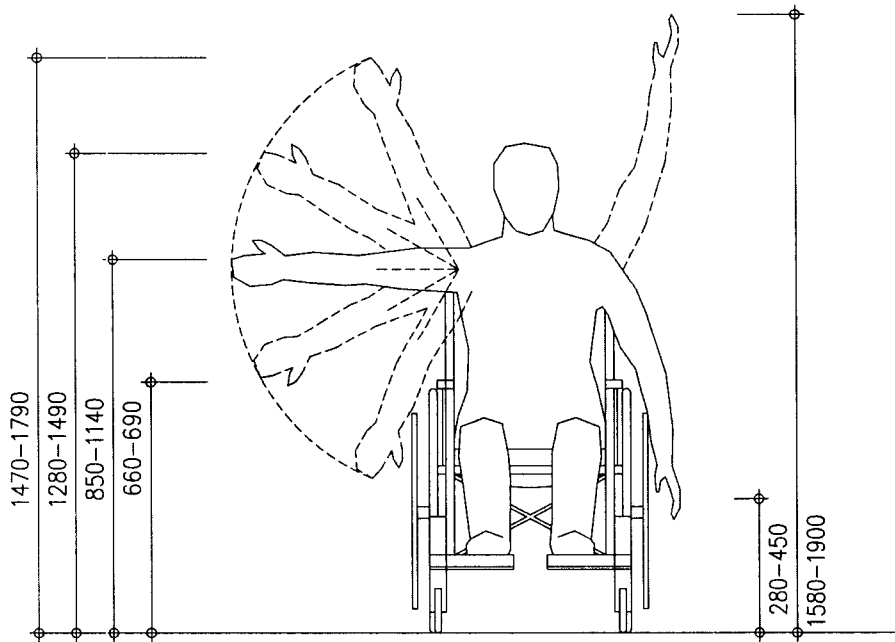

Figure A4 - Vertical Reaching Zones of a Wheelchair User

A.3 Forward reach of a wheelchair user

The maximum forward reach, without obstruction, is 1200 mm from the floor and the minimum forward reach is 400 mm from the floor as shown in **Figures A5 and A7**.

The maximum forward reach over an obstruction 500 mm deep is 1100 mm from the floor as shown in **Figure A6**.

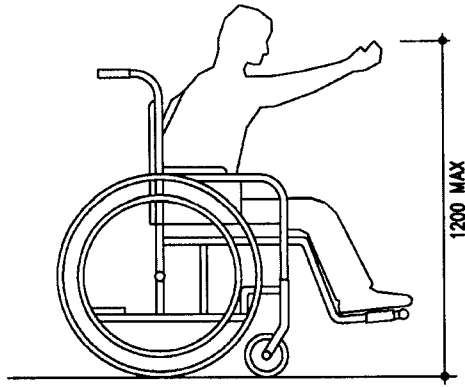

Figure A5 - Forward Reach

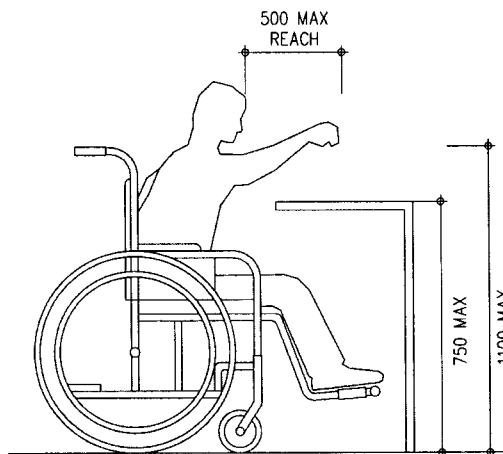

Figure A6 - Forward Reach Over Obstruction

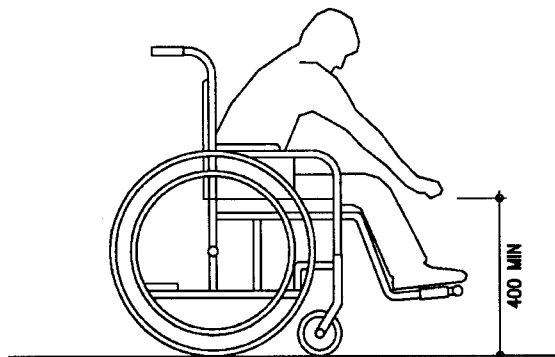

Figure A7 - Forward Reach Without Obstruction

A.4 Side reach

The maximum side reach, without obstruction, is 1300 mm from the floor and the minimum side reach is 250 mm from the floor as shown in **Figures A8 and A9**.

The maximum side reach over an obstruction 860 mm high by 500 mm deep is 1200 mm from the floor as shown in **Figure A10**

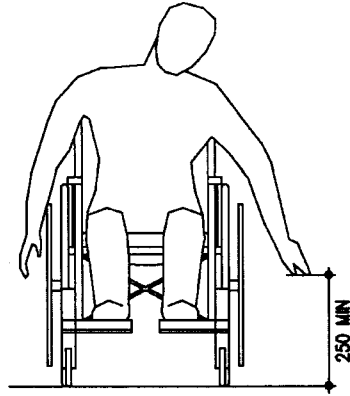

Figure A8 - Side Reach Without Obstruction

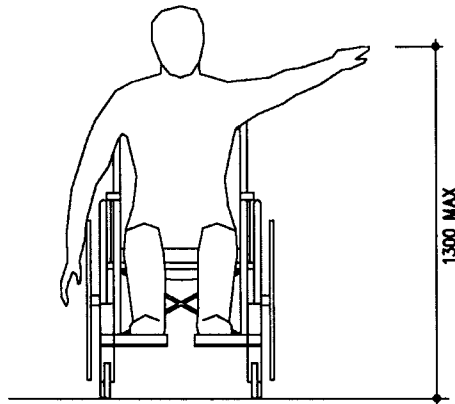

Figure A9 – Maximum Side Reach

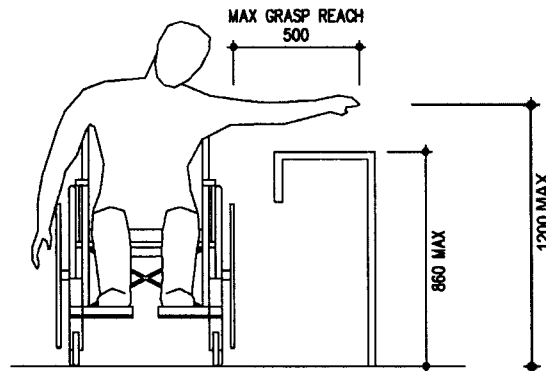
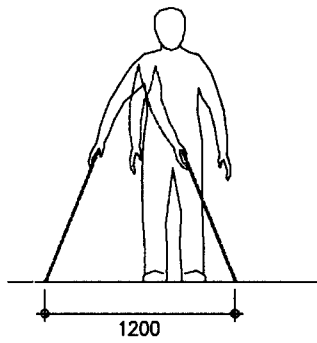
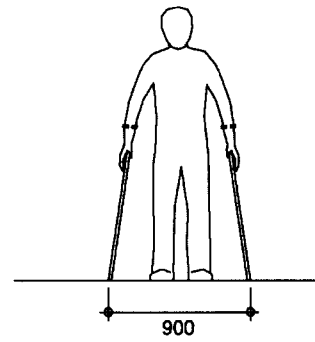

Figure A10 – Maximum Side Reach over an Obstruction



Persons with visual impairment using a long white cane



Persons using crutches

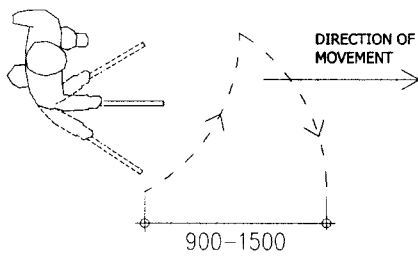

Detectable path dimension

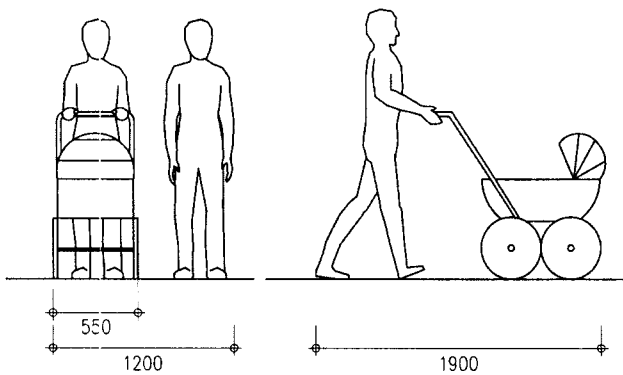

Person with baby carriage

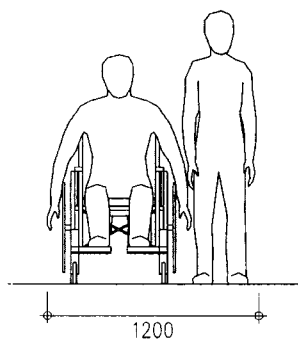

Path width for a person together with a wheelchair user

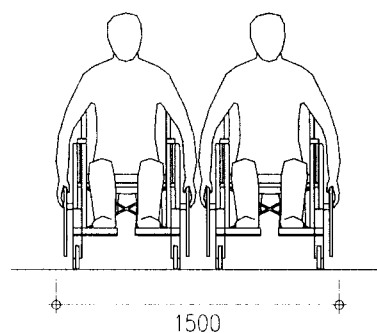

Path width for two wheelchair users

Figure A11 – Dimensions Required for General Pathway

Appendix B

Guidelines for Wheelchair Transfer and Movement

APPENDIX B

GUIDELINES FOR WHEELCHAIR TRANSFER AND MOVEMENT

B.1 Dimensions Of Wheelchairs

The dimensions of wheelchairs commonly used by persons with a disability in Hong Kong are provided at **Figure B1**.

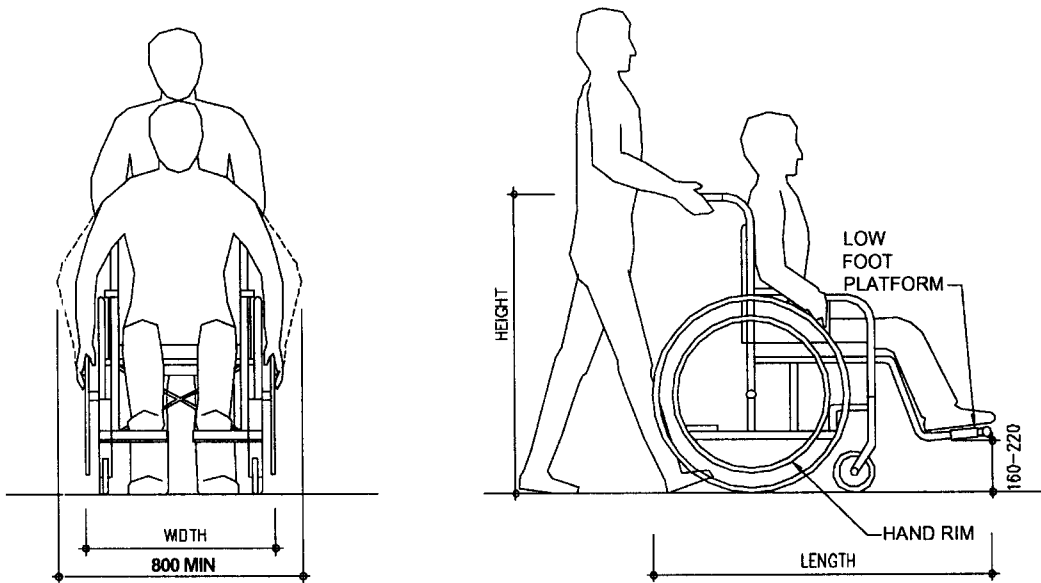

Type of Wheelchair	Width	Length	Height	Weight
Manual Wheelchair	510-725 mm	665-1100 mm	850-1140 mm	10-27 kg
Electric Wheelchair	520-700 mm	1060-1200 mm	1010-1400 mm	36-100 kg

Figure B1 - Dimensions of Wheelchair

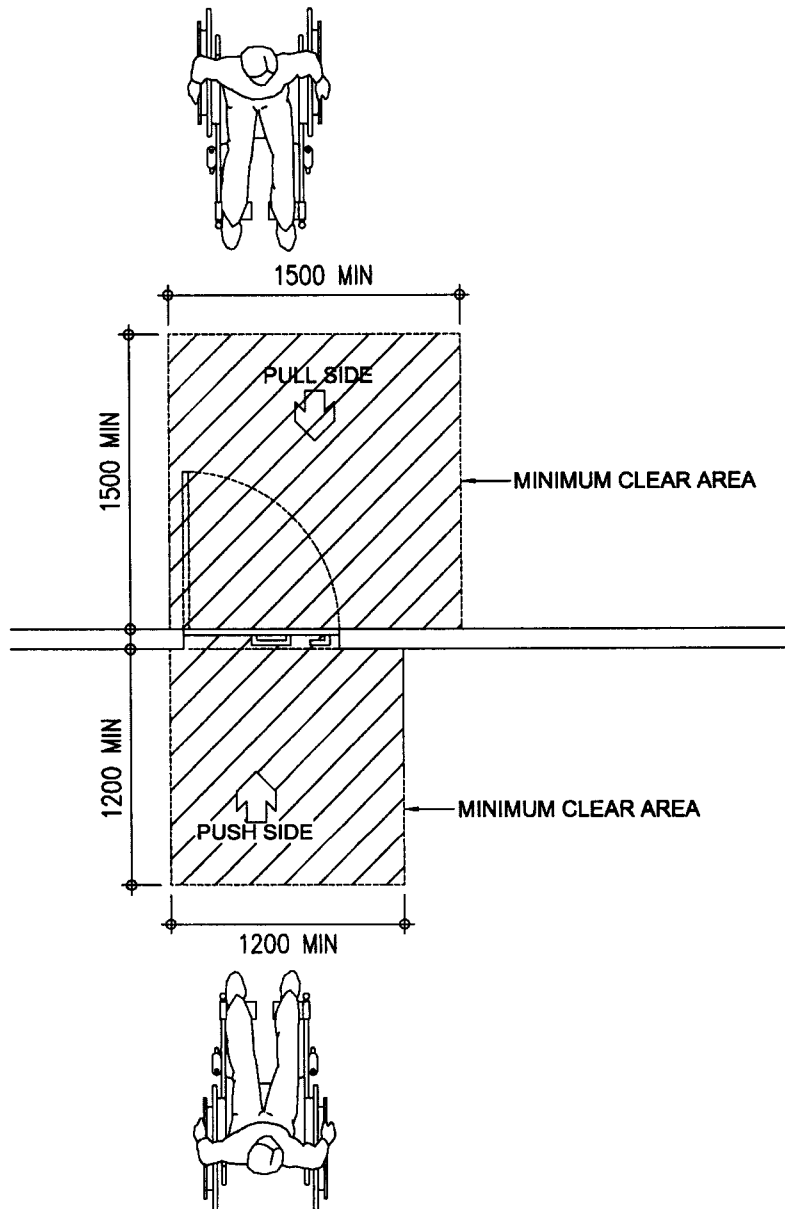
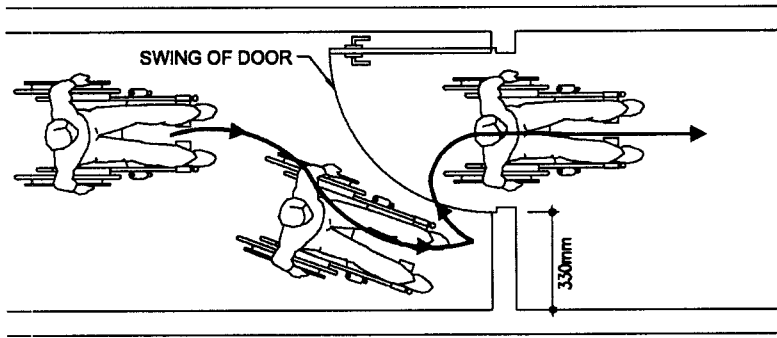

Figure B2 – Manoeuvring Spaces for Doorway

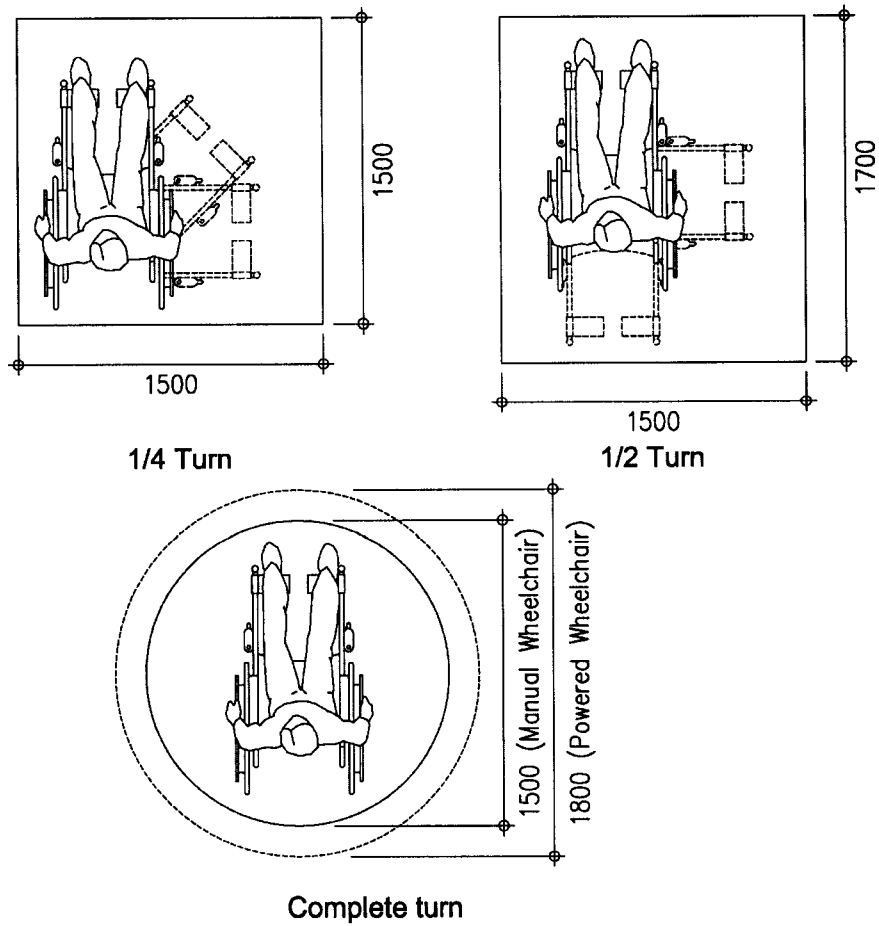

Figure B3 – Wheelchair Manoeuvring Space

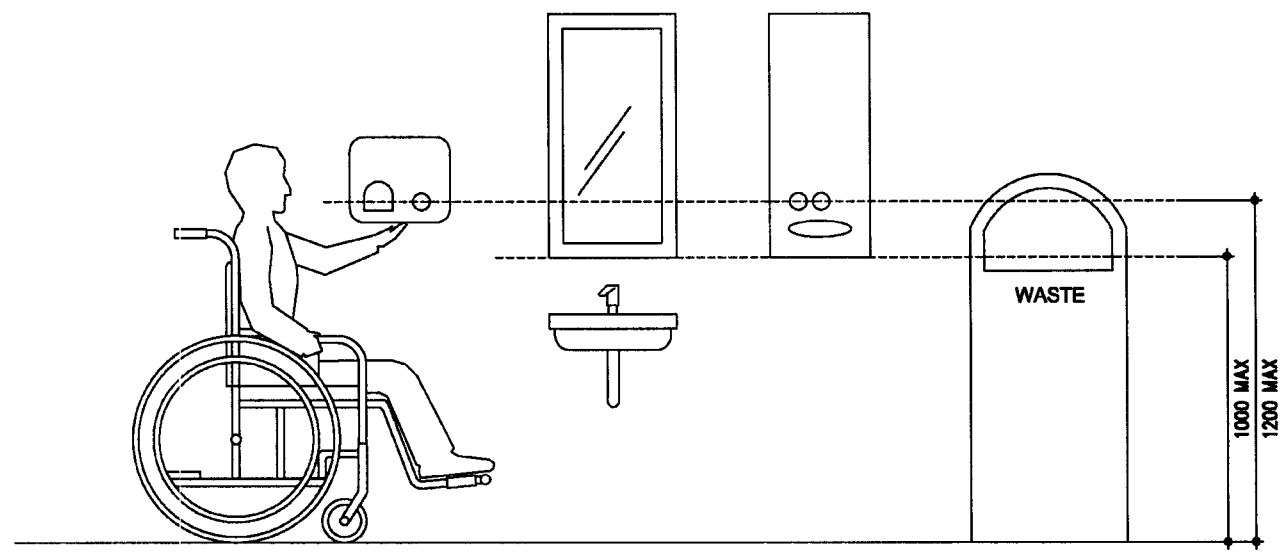
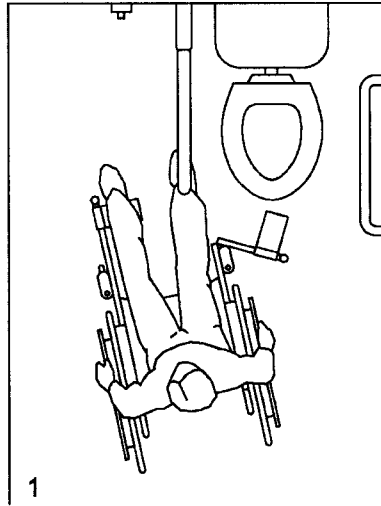
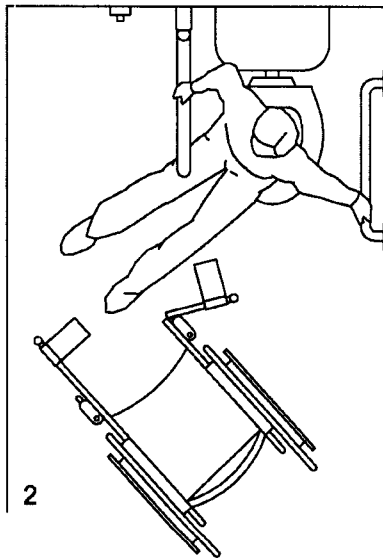

Figure B4 – Design Heights for Various Features



1
TAKES TRANSFER POSITION,
SWINGS FOOTREST OUT OF THE WAY,
SETS BRAKES



2
MOVES WHEELCHAIR OUT OF THE WAY,
CHANGES POSITION (SOME PEOPLE FOLD
CHAIR OR PILOT IT 90° TO THE TOILET)

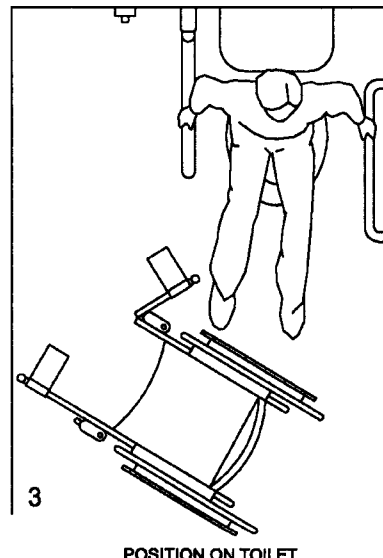

3
POSITION ON TOILET,
RELEASES BRAKES

Figure B5 – Diagonal Approach for Transferring from a wheelchair to a W.C. (Diagonal Approach)

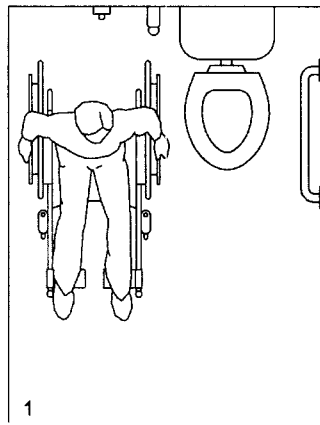

1

TAKES TRANSFER POSITION,
REMOVES ARMREST,
SETS BRAKES

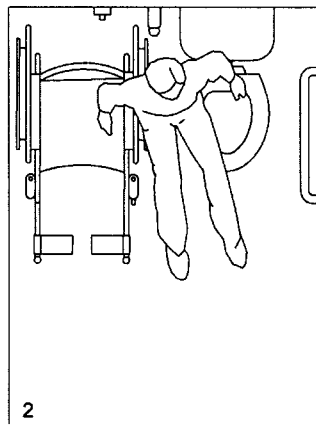

2

TRANSFERS

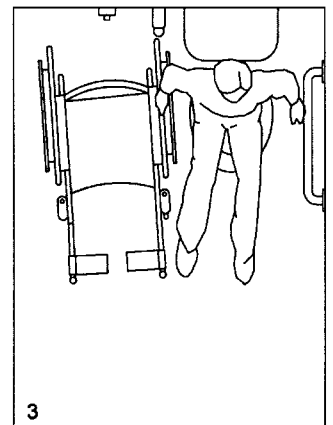

3

POSITION ON TOILET

Figure B6 – Side Approach for Transferring from a Wheelchair to a W.C.

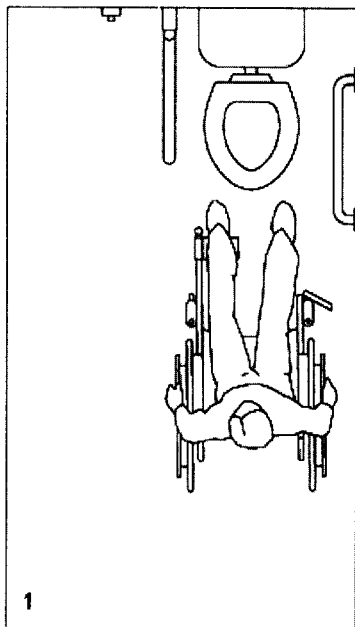

1

TAKES TRANSFER POSITION,
REMOVES ARMREST,
SETS BRAKES

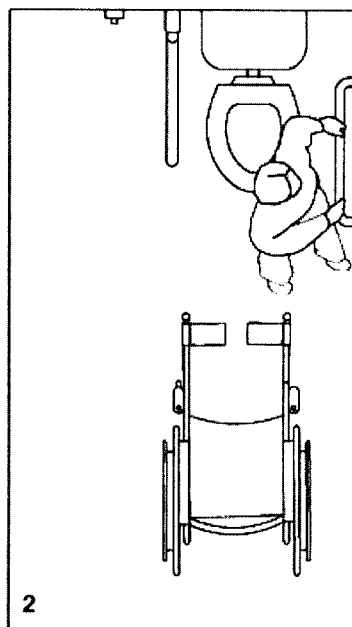

2

TRANSFERS

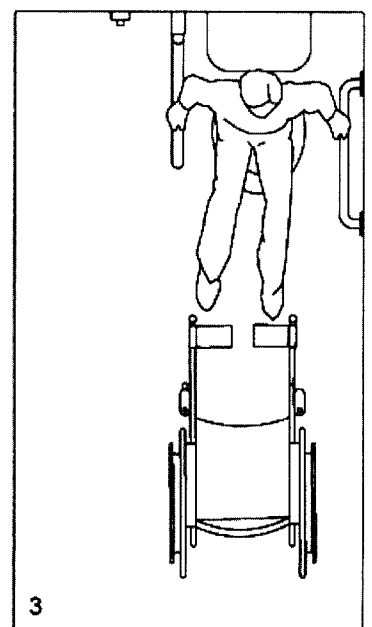

3

POSITION ON TOILET

Figure B7 – Frontal Approach for Transferring from a Wheelchair to a W.C.

Appendix C

Slip Resistance of Flooring Materials

APPENDIX C

SLIP RESISTANCE OF FLOORING MATERIALS

This appendix aims to provide design references of slip resistance for typical flooring materials and floor finishes.

Materials and finishes are graded under dry and wet conditions. The gradings given herein are for reference only, actual value of “static coefficient of friction” shall be subject to the manufacturer’s recommended characteristics.

Excessive slip resistance can also be hazardous since it may create unexpected grip on the surface.

Gradings based on “static coefficient of friction” measured in “dry” condition are classified by:

- “Very Good” - Material surface suitable for use in areas where special design care is required, with an approximate “static coefficient of friction” value of 0.8 or above.
- “Good” - Material surface satisfactory for normal use with an approximate “static coefficient of friction” value below 0.8 but at or above 0.5.
- “Fair” - Material surface with moderate potential for slip, with an approximate “static coefficient of friction” value below 0.5 but at or above 0.2.
- “Poor” - Unsafe material surface with high potential for slip, with an approximate “static coefficient of friction” value below 0.2.

Commentary:

Slip resistance is based on the frictional force required to keep a shoe heel or crutch tip from slipping on a walking surface. While the dynamic coefficient of friction during walking varies in a complex and non-uniform way, the static coefficient of friction, which can be measured in several ways, provides a close approximation of the slip resistance of a surface. However, it is generally recognized that the static coefficient of friction varies considerably due to the presence of contaminants, water, floor finishes, and other factors not under the control of the designer or builder and not subject to design and construction guidelines and that compliance of which would be difficult to measure on the building site. For details of method of measuring slip resistance, readers are suggested to make reference to some available overseas standards such as AS/NZS 4586-2004, AS/NZS 4663-2004, ASTM 1679, ASTM 1677, BS 7976-2, BS 8204 etc.

Appendix D

Luminous Contrast

APPENDIX D – Luminous Contrast

Types of contrast

Contrast refers to perceptible differences between different regions of an image or scene. There are two fundamental types of contrast:

- (a) Colour contrast, and
- (b) Luminous or brightness contrast.

Colour contrast

Colour contrast is the difference between colours positioned on a colour wheel. For example violet is the contrast to yellow, red is contrasted to green. Colours can contrast on the basis of their lightness, saturation or hue.

- (a) lightness measures the relative amount of light reflected from a colour;
- (b) saturation relates to its intensity; and
- (c) hue refers to elementary colour names, that is red, green, blue etc.

The perception of colour, however, can change with the type of light. Some people with visual impairment are unable to see colours as ageing and sight loss diminish their sensitivity of colour perception. Therefore colour contrast on its own may not be sufficient to provide a visual contrast.

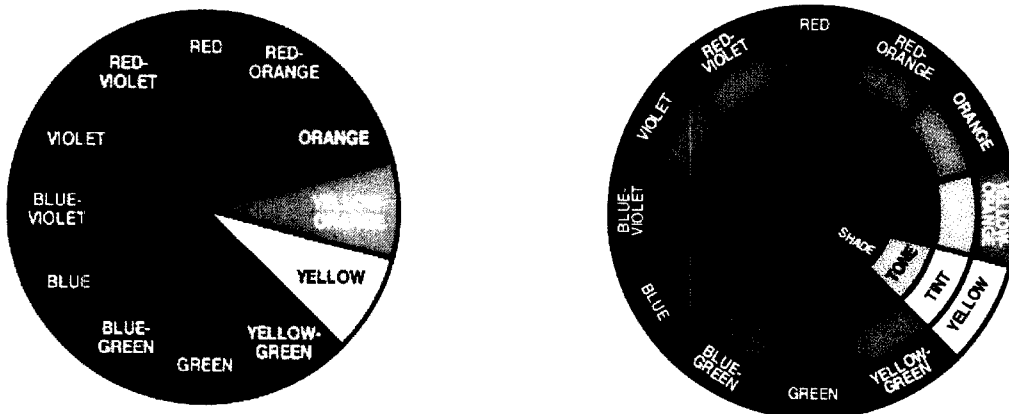

Tint: color + white, resulting in a lighter value

Tone: color + grey, resulting in a darker value

Shade: color + black, delivering the darkest versions of color

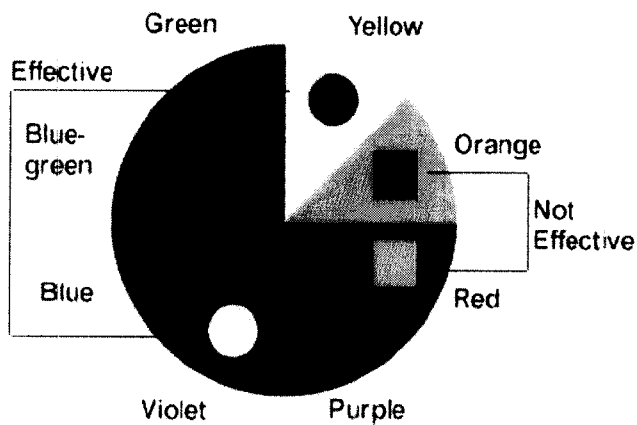

Luminous contrast

Luminous contrast is the amount of light reflected from one surface or component, compared to the amount of light reflected from the background or base surfaces. Luminous contrast is preferred to colour contrast because it offers light/dark differences that can be picked up more easily by people with visual impairment.

Two quite differently coloured surfaces may have a similar luminous. For example, cherry red on black has a high colour contrast but low luminous contrast and is not as visible as pale pink or yellow on black to people with visual impairment.

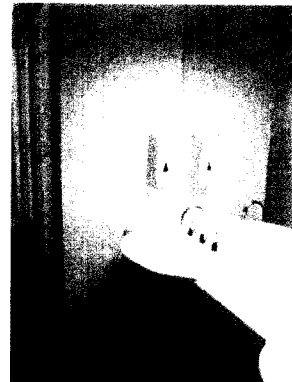
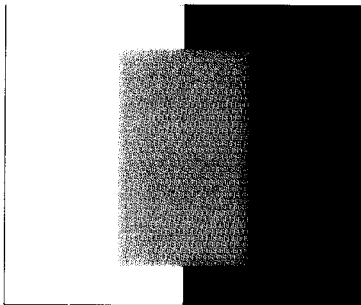

A 30% difference in luminous is generally the minimum discernible by a person with partial sight. Black and white have a 100% luminous contrast. Grey and black or grey and white have a 50% luminous contrast.

Measurement of Luminous Contrast

The light reflectance value of a subject can be measured by means of a luminance meter with a 1 degree measurement field. Measurement will be taken from a viewing height of 1600mm + 100mm and with an angle between 40 to 50 degree to the vertical in direction of approach.

“Luminous contrast” means the amount of light reflected from the surface of the object compared to the amount of light reflected from the surface of its surrounding background. Such contrast expressed in percent can be determined by:

$$[(B1-B2) / B1] \times 100$$

Where

B1 = light reflectance value (LRV) of the lighter area and

B2 = light reflectance value (LRV) of the darker area.

Lighting

Contrast will only be of assistance to people with visual impairment if there is an appropriate quantity and quality of illumination with which to view the contrasting elements. At low light levels, the perception of contrast diminishes. Lighting levels should generally be relatively uniform and about 25% higher for people with low vision. Strong directional lighting casts shadows that can mask contrasting surfaces. Significant fluctuations in illumination level can reduce visibility due to the slower adaptive response of the eye in someone with low vision.

Effective uses of luminous contrast include:

- Contrasting tactile warning strips to indicate the start and finish of a ramp;
- Contrasting doorframes, doors, skirting boards and architraves to assist with locating doors;
- Contrasting paving at doorways to assist with locating the entry;
- Contrasting edges of steps, a roadway or poles in play areas to highlight potential hazards.

