

立法會參考資料摘要

《2008年〈1995年飛航(香港)令〉(修訂)令》

引言

A 在二零零八年四月八日的會議上，行政會議**建議**，行政長官**指令**制訂載於**附件 A**的《2008年〈1995年飛航(香港)令〉(修訂)令》(《修訂令》)，以實施國際民航組織有關適航、飛機設備、安全管理、數據保存和人員牌照的最新規定主要條文和建議措施，以及適用於有關上述範疇的國際慣例。

理據

2. 《國際民用航空公約》(《芝加哥公約》)附件載有國際標準及建議措施，以規管航空事宜。為確保國際航空安全和符合規格起見，國際民航組織認為有關標準**需要**一致執行，所以《芝加哥公約》各締約國均須遵行有關國際標準，並確保其本國的規例或措施符合有關標準¹。此外，國際民航組織認為，為國際航空安全、符合規格和效率起見，一致執行各項建議措施最為理想，因此各締約國亦應該致力遵行有關措施。國際民航組織不時修訂標準及建議措施，並向締約國公布相關修訂，以便各締約國以立法和行政措施落實。

3. 《芝加哥公約》及其附件適用於香港。當局根據《民航條例》(第448章)第2A條訂立《1995年飛航(香港)令》(《命令》)，以施行《芝加哥公約》及其附件的主要條文，以及規管一般航空事宜。民航處一貫做法是以行政措施輔助落實《命

¹ 締約國若認為實際上難以遵行任何有關標準，須立即通知國際民航組織，說明本身措施與國際標準所規定的差異。

令》。事實上，過去十年，有關標準及建議措施以及適用的國際慣例的大部分修改，都是藉民航處發出的通知、通告和航空資料匯編等行政措施落實。

4. 雖然業界一般都會遵從這些行政文件訂明的規定，但我們認為宜修訂《命令》，以實施有關標準及建議措施以及適用的國際慣例的主要修改。事實上，國際民航組織在香港進行審查後²，指出有需要修訂法例。民航處會繼續沿用一貫做法，以行政措施輔助落實《命令》。

5. 《命令》的相關修訂主要涉及適航、飛機設備、安全管理、數據保存和人員牌照範疇，並加入新定義，以及刪除已過時的條文。主要修改扼述如下：

適航

- (a) 規定遭受損壞以致不再適航的飛機不得飛行(以及其適航證或認可證亦會失效)；
- (b) 承認根據民航處(行政長官授權下)與另一民航管理局就香港註冊飛機訂定的維修安排所發出的飛機維修許可；

飛機設備

- (c) 即使香港註冊的飛機並無配備擬定航程的指定設備，或設備性能欠佳，在指定情況下也准許該飛機飛行；
- (d) 規定飛機須配備區域導航設備和保持高度系統，以加強飛行安全；
- (e) 規定人員按照香港註冊飛機所適用的操作手冊，或飛機註冊國的法定程序操作機載防撞系統；

² 在二零零零及二零零四年，國際民航組織根據全球安全監察審查計劃在香港進行審查，以確定香港在飛機營運、飛機適航和人員牌照範疇，有否執行有關標準及建議措施。審查的結論指，香港的航空安全維持高水平，並對本港航空安全的政策、規則及架構安排等方面，給予正面評價。

安全管理

- (f) 規定航空公司、飛機維修機構、航空交通服務供應者和機場經營人推行安全管理系統；

數據保存

- (g) 規定一旦發生意外，相關飛機的經營者或機長須確保妥善保管所有相關飛行記錄器紀錄。而除非調查當局同意，否則不得重新啓動飛行記錄器，以利便航空意外調查；

人員牌照

- (h) 指明駕駛員和航空交通管制員操作無線電通話須具備的語文能力；
- (i) 增設一類駕駛員牌照；
- (j) 禁止飛機維修牌照持有人在健康欠佳或受對精神有影響的物品影響的情況下，行使牌照所賦予的權利；
- (k) 禁止航空交通管制員在健康欠佳或受對精神有影響的物品影響或感到疲倦的情況下，行使牌照所賦予的權利；
- (l) 更改見習航空交通管制員牌照、航空交通管制員牌照、商用駕駛員牌照及航線運輸駕駛員牌照的持有人的年齡限制；
- (m) 更新有關航空交通管制員懷孕的條文；
- (n) 修改若干類航空交通管制牌照類別的名稱

定義

- (o) 參照國際民航組織於《芝加哥公約》附件載列的定義，就“定翼機”、“飛機”、“客艙機組人員”、“飛行情報服務”、“機長”、“航空交通服務監察系統”、“對精神有影響的物品”等詞語採用新的定義。

其他修訂

- (p) 修訂《命令》相關條文，以配合根據第 83 分條作出的轉移(即根據《芝加哥公約》第 83 分條，飛機註冊國家可向飛機經營者國家作出的職能及職責的轉移)，例如《命令》第 7(1)條，關於飛機適航證事宜；以及
- (q) 鑑於民航業的發展及實施《命令》的經驗，刪除或闡明《命令》已過時的條文。舉例來說：
- (i) 由於“領航員牌照”不會再簽發或有效，因此無需提述該詞；
 - (ii) 不再需要規定飛行人員須包括領航員及飛行無線電報務員；
 - (iii) 人手操作的定向系統在香港現已停用，因此，有關禁止航空交通管制員操作這類系統的條文不合時宜；
 - (iv) 二零零五年十一月十日《2005 年航空保安(修訂)條例》生效後，禁止在飛機吸煙的條文已變得冗餘；
 - (v) “拯救性命”一詞需要進一步闡釋，以清楚涵蓋紀律部隊的滅火或防火、拯救性命或執法行動；
 - (vi) 香港並無規定提供指定機場飛行情報服務的機場飛行情報服務員須領有牌照。航空交通管制員提供的航空交通服務，包括在有需要時向駕駛員提供所需的飛行情報服務，因此無須訂定有關機場飛行情報服務員牌照的條文；
 - (vii) 香港發布的是《航空交通管制手冊》，並未有發布《飛行情報服務手冊》，而提供飛行情報服務的是持牌航空交通管制員，因此需要修訂有關條文；

- (viii) 應明文賦權核准人員在持牌航空交通管制員的指示下，向飛機傳達飛行指示或情報；以及
- (ix) 在界定氣球升空的情況時，應區分自由氣球與繫留氣球。

我們亦藉此機會，修正《命令》文本上的一些錯誤。

《修訂令》

6. 《修訂令》的主要條文載列如下：

- (a) **第 1 條**規定《修訂令》自民航處處長以憲報公告指定的日期起實施；
- (b) **第 3(1)、10、13(4)、27(1)、32(1)、33(1)、34(4)、35(2) 及 35(4)條**修訂《命令》多項條文，配合第 83 分條的轉移規定；
- (c) **第 4 條**在《命令》加入第 7A 條，禁止遭受損壞以致不再適航的飛機飛行。**第 5 條**修訂《命令》第 8(7)條，規定飛機如遭受損壞以致不再適航，飛機的適航證或認可證即告失效；
- (d) **第 8(11)、13(6)、13(7) 及 77(10)條**廢除《命令》多項有關領航員牌照的條文；
- (e) **第 8(12)條**在《命令》加入第 11(6A)條，承認根據行政長官與另一民航管理局就香港註冊飛機訂定的維修安排所發出的飛機維修許可；
- (f) **第 9(8)條**在《命令》加入第 12(7)及(8)條，規定飛機維修牌照持有人在健康欠佳或受到對精神有影響的物品影響的情況下，不得行使牌照所賦予的權利；
- (g) **第 11 條**在《命令》加入第 14A 條，准許香港註冊的飛機在指定情況下，即使並無配備擬定航程的指定設備，或設備性能欠佳，仍可飛行；

- (h) **第 12 條**修訂《命令》第 18 條，廢除飛行人員須包括領航員及飛行無線電報務員的規定；
- (i) **第 15 條**在《命令》加入第 20A 條，**第 51(12)條**修訂《命令》第 65 條，指明駕駛員及航空交通管制員操作無線電通話須具備的語文能力；
- (j) **第 29 條**在《命令》加入第 36A、36B、36C 及 36D 條，規管在香港空域飛行的飛機須配備的區域導航設備及保持高度系統；
- (k) **第 30 條**修訂《命令》第 37 條，規定一旦發生意外，相關飛機的經營者或機長須確保妥善保管所有相關飛行記錄器紀錄，而除非調查當局同意，否則不得重新啓動飛行記錄器，以利便航空意外調查；
- (l) **第 31 條**在《命令》加入第 37A 條，規定人員須按照香港註冊飛機所適用的操作手冊，或飛機註冊國家的法定程序操作機載防撞系統；
- (m) **第 33(2)、34(2)、35(3)及 82(3)條**修訂《命令》多項條文提述的“拯救性命”一詞，以進一步闡釋，清楚涵蓋紀律部隊的滅火或防火、拯救性命或執法行動；
- (n) **第 41 條**廢除禁止在飛機吸煙的條文；
- (o) **第 51 及 52 條**廢除有關機場飛行情報服務員牌照的條文；
- (p) **第 51 條**修訂《命令》第 65(1)條，修訂包括更改見習航空交通管制員牌照及航空交通管制員牌照的持有人的年齡限制；**第 77 條**修訂《命令》附表 9 第 A 部，更改商用駕駛員牌照及航線運輸駕駛員牌照的持有人的年齡限制；
- (q) **第 52(6)條**廢除禁止航空交通管制員操作人手操作的定向系統的條文；

- (r) **第 52(7)條**修訂《命令》第 66 條，明文賦權核准的人員可在持牌航空交通管制員的指示下，向飛機傳達飛行指示或情報；
- (s) **第 53 條**引入新的《命令》第 67 條，說明香港發布的是《航空交通管制手冊》，而不是《飛行情報服務手冊》，以及持牌航空交通管制員須遵從該手冊的要求；
- (t) **第 54 條**引入新的《命令》第 68(3)條，指明航空交通管制員懷孕期間及產後須遵守某些條件，方有資格行使牌照所賦予的權利；
- (u) **第 55 條**在《命令》加入第 68A 及 68B 條，禁止航空交通管制員在健康欠佳或受對精神有影響的物品影響或感到疲倦的情況下行使牌照所賦予的權利；
- (v) **第 68 條**修訂《命令》第 98(1)條，就“定翼機”、“飛機”、“客艙機組人員”、“飛行情報服務”、“機長”、“航空交通服務監察系統”及“對精神有影響的物品”等詞語引入新的定義；
- (w) **第 68(11)條**修訂《命令》第 98(3)條，在界定氣球升空的情況時，區分自由氣球與繫留氣球；
- (x) **第 69 條**在《命令》加入第 102 條，規定航空公司、飛機維修機構、航空交通服務供應者(或機構)和機場經營人推行安全管理系統；
- (y) **第 77 條**修訂《命令》附表 9，增設一類駕駛員牌照，作為更新有關飛機飛行人員、牌照及牌照類別規定的一部分；以及
- (z) **第 78 條**修訂《命令》附表 10，修改某幾類航空交通管制牌照類別的名稱。

B 7. 《修訂令》修訂的相關現行條文載於附件 B。

立法程序時間表

8. 《修訂令》會在二零零八年四月十八日刊登憲報，並在二零零八年四月二十三日提交立法會。

建議的影響

9. 建議對財政、公務員、生產力、可持續發展和環境均沒有影響。至於經濟影響方面，預料《修訂令》不會令航空服務供應商承擔額外開支，因為當局已經以行政措施執行國際民航組織的最新規定。

10. 《修訂令》符合《基本法》，包括有關人權的條文。《修訂令》不影響現行法例的約束力。

公眾諮詢

11. 民航處擬備修訂建議時，曾諮詢航空發展諮詢委員會的技術小組委員會及航空業，包括本港航空公司、香港航空公司代表協會、國際航空運輸協會、政府飛行服務隊、維修機構、香港飛行總會，以及其他相關組織，例如香港航空交通管制協會、香港航空機組人員協會、香港航空公司機師協會及國泰航空公司空中服務員工會。他們普遍支持建議的修訂。

12. 在二零零七年七月十八日，我們徵詢立法會經濟事務委員會的意見。委員會對立法建議並無異議。

宣傳安排

13. 我們會在二零零八年四月十六日發出新聞稿，並安排發言人解答查詢。

背景

14. 國際民航組織根據《國際民用航空公約》成立，是全球最重要的民航組織。該組織現有 190 個締約國，中國為其中一員。該組織的宗旨是推動國際間以安全和有秩序的方式發展民航業務，同時確保國際間的航空運輸業務可在機會均等的基礎上，穩健地按經濟原則經營。

15. 當局根據《民航條例》第 2A 條制訂《命令》，以規管飛機的註冊及標誌、航空運輸企業的經營許可證、飛機的適航標準及設備、飛機的營運、航空交通的管制、空中交通規則、機場牌照簽發及航行燈、人員牌照事宜、文件和紀錄等。

查詢

16. 如對本摘要有任何查詢，請與運輸及房屋局首席助理秘書長（運輸）鄭港涌先生（電話號碼：2810 2687）聯絡。

運輸及房屋局

二零零八年四月十六日

《2008 年〈1995 年飛航(香港)令〉(修訂)令》

目錄

| 條次 | | 頁次 |
|-----|---|----|
| 1. | 生效日期 | 1 |
| 2. | Aircraft to be registered | 1 |
| 3. | Certificate of airworthiness to be in force | 1 |
| 4. | 加入條文 | |
| | 7A. Damage to aircraft | 2 |
| 5. | Issue, renewal, etc., of certificates of airworthiness | 3 |
| 6. | Certificate of maintenance review | 4 |
| 7. | Technical log | 5 |
| 8. | Inspection, overhaul, repair, replacement and modification | 5 |
| 9. | Licensing of maintenance engineers | 7 |
| 10. | Radio equipment of aircraft | 8 |
| 11. | 加入條文 | |
| | 14A. Minimum equipment requirements | 9 |
| 12. | Composition of crew of aircraft | 10 |

| 條次 | | 頁次 |
|-----|---|----|
| 13. | Members of flight crew - requirement of licences | 10 |
| 14. | Grant, renewal and effect of Flight Crew Licences | 13 |
| 15. | 加入條文 | |
| | 20A. Endorsement in respect of language proficiency | 14 |
| 16. | Personal flying log book | 15 |
| 17. | Instruction in flying | 15 |
| 18. | Training manual | 15 |
| 19. | Public transport - operator's responsibilities | 15 |
| 20. | Loading - public transport aircraft and suspended loads | 15 |
| 21. | Public transport - operating conditions | 16 |
| 22. | Aircraft registered in Hong Kong - Aerodrome operating minima | 16 |
| 23. | Aircraft not registered in Hong Kong - aerodrome operating minima | 18 |
| 24. | Pre-flight action by commander of aircraft | 19 |
| 25. | Pilots to remain at controls | 20 |

| 條次 | | 頁次 |
|-----|---|----|
| 26. | Public transport of passengers - duties of commander | 20 |
| 27. | Operation of radio in aircraft | 21 |
| 28. | Minimum navigation performance | 22 |
| 29. | 加入條文 | |
| | 36A. Area navigation and required navigation performance capabilities - aircraft registered in Hong Kong | 23 |
| | 36B. Area navigation and required navigation performance capabilities - aircraft registered outside Hong Kong | 24 |
| | 36C. Height keeping performance capabilities - aircraft registered in Hong Kong | 25 |
| | 36D. Height keeping performance capabilities - aircraft registered outside Hong Kong | 26 |
| 30. | Use of flight recording systems and preservation of records | 27 |
| 31. | 加入條文 | |
| | 37A. Use of airborne collision avoidance system | 28 |

| 條次 | | 頁次 |
|-----|---|----|
| 32. | Towing of gliders | 29 |
| 33. | Towing, picking up and raising of persons and articles | 30 |
| 34. | Dropping of animals and articles | 31 |
| 35. | Dropping of persons | 32 |
| 36. | Carriage of weapons and of munitions of war | 33 |
| 37. | Exits and break-in markings | 34 |
| 38. | Imperilling safety of aircraft | 34 |
| 39. | Imperilling safety of any person or property | 34 |
| 40. | Drunkenness in aircraft | 34 |
| 41. | Smoking in aircraft | 35 |
| 42. | Authority of commander of aircraft | 36 |
| 43. | Stowaways | 36 |
| 44. | Fatigue of crew - responsibilities of crew | 36 |
| 45. | Records to be kept | 36 |
| 46. | Production of documents and records | 37 |
| 47. | Preservation of documents, etc. | 37 |
| 48. | Revocation, suspension and variation of certificates, licences and other documents | 38 |

| 條次 | | 頁次 |
|-----|---|----|
| 49. | Rules of the air | 38 |
| 50. | Provision of air traffic services | 38 |
| 51. | Licensing of air traffic controllers, student air traffic controllers and aerodrome flight information service officers | 38 |
| 52. | Prohibition of unlicensed air traffic controllers, student air traffic controllers and aerodrome flight information service officers | 41 |
| 53. | 取代條文 | |
| | 67. Manual of Air Traffic Control | 42 |
| 54. | Incapacity of air traffic controllers | 42 |
| 55. | 加入條文 | |
| | 68A. Air traffic controllers not to exercise privileges of licences or use psychoactive substances in certain circumstances | 43 |
| | 68B. Fatigue of air traffic controller - air traffic controller's responsibilities | 44 |
| 56. | Power to prohibit or restrict flying | 45 |

| 條次 | | 頁次 |
|-----|--|----|
| 57. | Balloons, kites, airships, gliders and parascending parachutes | 45 |
| 58. | Aerodromes: public transport of passengers and instruction in flying | 45 |
| 59. | Aeronautical radio stations | 45 |
| 60. | Aeronautical radio station records | 45 |
| 61. | Aeronautical lights | 46 |
| 62. | Flights over any place outside Hong Kong | 46 |
| 63. | Mandatory reporting | 46 |
| 64. | Power to prevent aircraft flying | 47 |
| 65. | Penalties | 47 |
| 66. | Application of Order to Chinese controlled aircraft not registered in Hong Kong | 47 |
| 67. | Appeal to High Court | 47 |
| 68. | Interpretation | 48 |
| 69. | 加入條文 | |
| | 102. Safety management system | 54 |
| 70. | 修訂附表 1 | 56 |

| 條次 | | 頁次 |
|-----|---|-----|
| 71. | 取代附表 2 | |
| | Schedule 2 A and B Conditions | 59 |
| 72. | Categories of Aircraft | 67 |
| 73. | Aerodrome Manual | 67 |
| 74. | Aircraft Equipment | 67 |
| 75. | Radio and Radio Navigation Equipment to be carried in Aircraft | 88 |
| 76. | Areas specified in connection with the carriage of Flight Navigators as members of the Flight Crews or Approved Navigational Equipment on Public Transport Aircraft | 92 |
| 77. | Flight Crew of Aircraft, Licences and Ratings | 92 |
| 78. | Air Traffic Controllers: Ratings | 100 |
| 79. | Public Transport – Operational Requirements | 103 |
| 80. | Documents to be Carried by Aircraft Registered in Hong Kong | 105 |
| 81. | 修訂附表 13 | 107 |
| 82. | Rules of the Air | 111 |
| 83. | Air Navigation (General) Regulations | 116 |

條次

頁次

84. The Air Navigation (Dangerous Goods)
Regulations

124

《2008年〈1995年飛航(香港)令〉(修訂)令》

(由行政長官會同行政會議根據《民航條例》
(第448章)第2A條作出)

1. 生效日期

本命令自民航處處長以憲報公告指定的日期起實施。

2. Aircraft to be registered

《1995年飛航(香港)令》(第448章, 附屬法例C)第3(1)條現予修訂, 在但書第(i)(b)段中, 在““B Conditions””之後加入“(except paragraph (1)(a))”。

3. Certificate of airworthiness to be in force

(1) 第7(1)條現予修訂, 廢除在“Provided that”之前的所有字句而代以 —

“(1) An aircraft shall not fly unless —

(a) there is in force in respect of the aircraft a certificate of airworthiness duly issued or rendered valid under the law of —

(i) if there is no Article 83 bis transfer of the functions and duties under Article 31 of the Chicago Convention in respect of the aircraft, the country in which the aircraft is

registered; or

(ii) if there is such a transfer, the state of the operator of the aircraft; and

(b) the conditions subject to which the certificate was issued or rendered valid are complied with.”。

(2) 第 7(1)條現予修訂，廢除 —

“Provided that the foregoing prohibition”

而代以 —

“(1A) Paragraph (1) of this Article”。

(3) 第 7(1A)(b)條現予修訂，廢除 “, if it is not being used for the public transport of passengers” 而代以 “flying on a private flight”。

4. 加入條文

現加入 —

“7A. Damage to aircraft

An aircraft shall not fly if the aircraft has sustained damage of a nature such that the aircraft is no longer considered airworthy by —

- (a) if there is no Article 83 bis transfer of the functions and duties under Article 31 of the Chicago Convention in respect of the aircraft, the country in which the aircraft is registered; or
- (b) if there is such a transfer, the state of the operator of the aircraft.” ◦

5. Issue, renewal, etc., of certificates of airworthiness

(1) 第 8(7)(b)條現予廢除，代以 —

“(b) until the completion of:

(i) the inspection of the aircraft or of the equipment referred to in subparagraph (a) of this paragraph made for the purpose of ascertaining whether the aircraft remains airworthy; or

(ii) the maintenance of the aircraft or of the equipment referred to in subparagraph (a) of this paragraph,

being an inspection or maintenance:

(iii) classified as mandatory by the Chief Executive; or

(iv) required by a maintenance schedule approved by the Chief Executive in relation to the aircraft;” ◦

(2) 第 8(7)(c)條現予修訂 —

- (a) 廢除 “or of any such equipment as aforesaid” 而代以 “or of the equipment referred to in subparagraph (a) of this paragraph” ；
 - (b) 廢除句號而代以 “; or” 。
- (3) 第 8(7)條現予修訂，加入 —
- “(d) if the aircraft has sustained damage of a nature such that, in the opinion of the Chief Executive, the aircraft is no longer airworthy.” 。

6. Certificate of maintenance review

(1) 第 9(1)條現予修訂，廢除 “in either the transport or in the aerial work category” 。

(2) 第 9(1)(b)條現予修訂，在 “there is” 之前加入 “in the case of an aircraft in respect of which a certificate of airworthiness in either the transport or the aerial work category is in force,” 。

(3) 第 9(2)條現予修訂，廢除 “The” 而代以 “In relation to an aircraft in respect of which there has been issued a certificate of airworthiness in either the transport or the aerial work category, the” 。

(4) 第 9(3)(a)條現予修訂，廢除 “aircraft maintenance engineer’s licence” 而代以 “aircraft maintenance licence” 。

(5) 第 9(3)條現予修訂，在但書中，廢除 “its” 而代以 “his” 。

(6) 第 9(7)條現予廢除。

7. Technical log

(1) 第 10(1)條現予修訂，廢除 “in the” 而代以 “the” 。

(2) 第 10(2)條現予修訂，廢除 “the commander of the aircraft shall” 而代以 “the pilot in command of the aircraft shall” 。

(3) 第 10(2)條現予修訂，在但書第(iii)段中，廢除 “as commander” 而代以 “as pilot in command” 。

(4) 第 10(2)條現予修訂，在但書中，廢除 “the commander of an aircraft” 而代以 “the pilot in command of an aircraft” 。

8. Inspection, overhaul, repair, replacement and modification

(1) 第 11 條現予修訂，在第(1)款之前加入 —

“(1A) This Article shall apply to an aircraft :

(a) that is registered in Hong Kong;
and

(b) in respect of which a certificate of airworthiness issued or rendered valid under this Order is in force.” 。

(2) 第 11(1)條現予修訂，廢除 “registered in Hong Kong, being an aircraft in respect of which a certificate of airworthiness issued or rendered valid under this Order is in force,” 。

(3) 第 11(1)條現予修訂，在但書第(i)段中，廢除 “commander” 而代以 “pilot in command” 。

(4) 第 11(1)條現予修訂，在但書中，廢除 “commander of the aircraft shall” 而代以 “pilot in command shall” 。

(5) 第 11(3)條現予修訂，廢除 “whether” 而代以 “either” 。

(6) 第 11(4)(a)條現予修訂，廢除 “requipment” 而代以 “equipment” 。

(7) 第 11(4)條現予修訂，廢除 “registered in Hong Kong” 。

(8) 第 11(5)(a)條現予修訂，廢除 “be” 而代以 “be, ” 。

(9) 第 11(6)(a)條現予修訂，廢除 “aircraft maintenance engineer’s licence” 而代以 “aircraft maintenance licence” 。

(10) 第 11(6)(b)條現予修訂，廢除 “aircraft maintenance engineer’s licence or authorisation as such an engineer” 而代以 “aircraft maintenance licence or an authorization as an aircraft maintenance engineer” 。

(11) 第 11(6)(e)條現予修訂，廢除 “or a Flight Navigator’s Licence” 。

(12) 第 11 條現予修訂，加入 —

“(6A) Notwithstanding paragraph (6) of this Article, a certificate of release to service issued under a maintenance arrangement made by the Chief Executive with a civil aviation authority shall be deemed to be a certificate of release to service issued for the purposes of this Article.” 。

(13) 第 11(9)條現予廢除 。

9. Licensing of maintenance engineers

(1) 第 12(1)條現予修訂，廢除 “aircraft maintenance engineer’s licences” 而代以 “an aircraft maintenance licence” 。

(2) 第 12(2)條現予修訂，廢除 “aircraft maintenance engineer’s licence” 而代以 “aircraft maintenance licence” 。

(3) 第 12(2)條現予修訂，廢除 “to issue:” 而代以 “to exercise the following privileges –” 。

(4) 第 12(2)(a)條現予修訂，廢除 “certificates of a” 而代以 “to issue certificates of” 。

(5) 第 12(2)(b)條現予修訂，在 “certificates” 之前加入 “to issue” 。

(6) 第 12(2)(c)條現予修訂，在 “certificates” 之前加入 “to issue” 。

(7) 第 12(5)條現予廢除，代以 —

“(5) An aircraft maintenance licence granted under this Article shall not be valid unless it bears the ordinary signature of the holder of the licence in ink.” 。

(8) 第 12 條現予修訂，加入 —

“(7) The holder of an aircraft maintenance licence –

(a) shall not exercise the privileges of the licence if he knows or reasonably suspects that his physical or mental condition renders him unfit to exercise such privileges; and

(b) shall not, when exercising the privileges of the licence, be under the influence of psychoactive substances which may render him unable to safely and properly exercise such privileges.

(8) The holder of an aircraft maintenance licence shall not engage in the use of psychoactive substances in a way that –

(a) constitutes a direct hazard to the holder or endangers the lives, health or welfare of others; or

(b) causes or worsens an occupational, social, physical or mental problem or disorder of the holder.” ◦

10. Radio equipment of aircraft

第 14(1)條現予廢除，代以 —

“(1) An aircraft shall not fly unless it is so equipped with radio and radio navigation equipment –

(a) as to comply with the law of –

(i) if there is no Article 83 bis transfer of the functions and duties under Article 30 of the Chicago Convention in respect of the aircraft, the country in which the aircraft is registered; or

- (ii) if there is such a transfer, the state of the operator of the aircraft; and
- (b) to enable communications to be made and the aircraft to be navigated in accordance with the provisions of this Order and any regulations made under this Order including, in particular, Schedule 15 to this Order.” ◦

11. 加入條文

現加入 —

“14A. Minimum equipment requirements

(1) The Chief Executive may, in respect of any aircraft or class of aircraft registered in Hong Kong, grant a permission permitting such aircraft to commence a flight in specified circumstances.

(2) An aircraft registered in Hong Kong shall not commence a flight if any of the equipment required by or under this Order to be carried in the circumstances of the intended flight is not carried or is not in a fit condition for use unless —

- (a) the aircraft does so under and in accordance with the terms of a permission granted under this Article; and

- (b) in the case of an aircraft to which Article 25 of this Order applies, the operations manual required under that Article contains particulars of the permission.”。

12. Composition of crew of aircraft

(1) 第 18(3)(b)條現予修訂，廢除“aircraft commander”而代以“pilot in command”。

(2) 第 18(4)(a)條現予廢除。

(3) 第 18(4)條現予修訂，廢除在“to this Order.”之後的所有字句。

(4) 第 18(5)條現予廢除。

(5) 第 18(7)(b)條現予修訂，廢除在“include”之後的所有字句而代以“members of the cabin crew.”。

(6) 第 18(7)(c)條現予修訂，廢除“cabin attendant”而代以“member of the cabin crew”。

(7) 第 18(7)條現予修訂，在但書中，廢除“cabin attendants”而代以“members of the cabin crew”。

(8) 第 18(8)條現予修訂，廢除兩度出現的“cabin attendants”而代以“members of the cabin crew”。

13. Members of flight crew – requirement of licences

(1) 第 19(1)條現予修訂，在但書(d)(iv)段中，廢除句號而代以分號。

(2) 第 19(1)條現予修訂，在但書中，加入 —

“(e) subject to Article 20(8) of this Order, act as pilot in command of a balloon if —

- (i) he is the holder of an appropriate licence granted or rendered valid under this Order in all respects and he has not within the immediately preceding 13 months carried out as pilot in command in a balloon at least 5 flights each of not less than 5 minutes duration;
- (ii) he so acts in accordance with instructions given by a person authorized by the Chief Executive to supervise flying in the type of balloon being flown;
- (iii) no person other than that specified in sub-paragraph (ii) is carried; and
- (iv) the balloon is not flying for the purpose of public transport or aerial work other than aerial work which consists of the giving of instruction in flying or the conducting of flying tests.”。

(3) 第 19(2)條現予修訂，廢除 “in a country other than” 而代以 “outside”。

(4) 第 19(2)(a)條現予修訂，廢除 “of the country in which the aircraft is registered; or” 而代以 —

“of –

- (i) if there is no Article 83 bis transfer of the functions and duties under Article 32 a) of the Chicago Convention in respect of the aircraft, the country in which the aircraft is registered; or
- (ii) if there is such a transfer, the state of the operator of the aircraft; or”。

(5) 第 19(3)條現予廢除。

(6) 第 19(4)(b)(ii)條現予修訂，廢除 “, a flight navigator’s”。

(7) 第 19(5)條現予修訂，廢除 “a flight navigator’s or”。

(8) 第 19(8)(a)條現予廢除。

(9) 第 19(8)(b)條現予修訂，廢除 “of the giving of instruction in flying in a glider owned or operated by a flying club of which the person giving and the person receiving instruction are both members.” 而代以 —

“of –

- (i) the giving of instruction in flying in a glider owned or operated by a flying club of which the person giving the instruction and the person receiving the instruction are both members; or
- (ii) the conducting of flying tests in a glider owned or operated by a flying club of which the person conducting the test and the person undergoing the test are both members.”。

14. Grant, renewal and effect of Flight Crew Licences

(1) 第 20(1)(a)條現予修訂，在“skill,”之後加入“language ability, and”。

(2) 第 20(1)條現予修訂，廢除但書。

(3) 第 20(4)(b)條現予廢除。

(4) 第 20(7)(a)條現予修訂，在“operator’s”之後加入“restricted”。

(5) 第 20(7)(d)條現予廢除，代以 —

“(d) Where the medical examination is conducted outside Hong Kong —

(i) the person conducting the examination shall make a report to the Chief Executive;

(ii) the Chief Executive, or any person in Hong Kong approved by him as competent to do so, may, on the basis of the report and subject to such conditions as he thinks fit, issue a medical certificate to the effect that he has assessed the holder of the licence as fit to perform the functions to which the licence relates; and

(iii) the certificate shall, without prejudice to paragraph (8) of this Article, be valid for such period as is specified in the certificate and shall be deemed to form part of the licence.”。

(6) 第 20(8)(a)條現予修訂，在“suspects”之前加入“reasonably”。

15. 加入條文

現加入 —

“20A. Endorsement in respect of language proficiency

(1) The Chief Executive may include in a licence granted under Article 20 of this Order an endorsement in respect of language proficiency, subject to such conditions as he thinks fit, on his being satisfied that the licence holder has demonstrated the ability to speak and understand the language used for radiotelephony communications.

(2) The endorsement shall be valid for the period specified in the licence.

(3) A person shall not act as a member of the flight crew of an aircraft registered in Hong Kong in or over a place outside Hong Kong unless his licence bears a valid language proficiency endorsement and the conditions subject to which the endorsement was made are complied with.”。

16. Personal flying log book

(1) 第 22(1)條現予修訂，廢除 “Member” 而代以 “member” 。

(2) 第 22(2)(d)條現予修訂，廢除 “night-flying” 而代以 “night flying” 。

17. Instruction in flying

第 23(2)條現予修訂，在但書中，廢除 “if flying” 而代以 “in flying” 。

18. Training manual

第 26(3)(a)條現予修訂，廢除 “applied” 而代以 “applies” 。

19. Public transport – operator’s responsibilities

(1) 第 27(1)(a)條現予修訂，廢除 “commander” 而代以 “pilot in command” 。

(2) 第 27(3)條現予修訂，在 “passengers” 之後加入 “or cargo” 。

20. Loading – public transport aircraft and suspended loads

(1) 第 28(4)條現予修訂，廢除 “himself the commander” 而代以 “himself the pilot in command” 。

(2) 第 28(4)條現予修訂，廢除 “by the commander” 而代以 “by the pilot in command” 。

(3) 第 28(4)條現予修訂，在但書(a)段中，廢除“commander”而代以“pilot in command”。

21. Public transport – operating conditions

(1) 第 29(2)條現予修訂，廢除“commander”而代以“pilot in command”。

(2) 第 29(5)條現予修訂，廢除“so as to be more than 20 seconds flying time from”而代以“beyond”。

(3) 第 29(6)條現予修訂，廢除“A2 shall not fly over water for the purpose of public transport for more than 15 minutes during any flight”而代以“A1 or A2 shall not fly over water for the purpose of public transport beyond a distance from land corresponding to more than 10 minutes at its normal cruise speed”。

22. Aircraft registered in Hong Kong – Aerodrome operating minima

(1) 第 30(1)(a)條現予修訂，在但書中，廢除“commander”而代以“pilot in command”。

(2) 第 30(1)(b)條現予修訂，廢除“commander”而代以“pilot in command”。

(3) 第 30(4)(b)條現予修訂，廢除“commander”而代以“pilot in command”。

(4) 第 30(5)條現予廢除，代以 —

“(5) Without prejudice to paragraph (5A) of this Article, an aircraft to which Article 25 of this Order applies, when making an instrument approach to an aerodrome –

- (a) if the relevant runway visual range at the aerodrome is at the time less than the specified minimum for landing, shall not continue the approach below 1 000 feet above the height of the aerodrome; or
- (b) if the reported visibility or controlling runway visual range at the aerodrome falls below the specified minimum after the aircraft has descended below 1 000 feet above the height of the aerodrome, may continue the approach to –
 - (i) the decision altitude or decision height; or
 - (ii) the minimum descent altitude or minimum descent height.

(5A) Unless the specified visual reference for landing is established and maintained, an aircraft to which Article 25 of this Order applies shall not continue its approach to land at an aerodrome below –

- (a) the decision altitude or decision height; or
- (b) the minimum descent altitude or minimum descent height.” °

(5) 第 30(6)條現予修訂，廢除 “Air Traffic Control” 而代以 “air traffic control unit” 。

(6) 第 30(6)條現予修訂，廢除 “commander” 而代以 “pilot in command” 。

(7) 第 30(7)條現予修訂，廢除 “commander” 而代以 “pilot in command” 。

23. Aircraft not registered in Hong Kong – aerodrome operating minima

(1) 第 31 條的標題現予修訂，廢除 “**not registered in**” 而代以 “**registered outside**” 。

(2) 第 31(1)條現予修訂，廢除 “in a country other than” 而代以 “outside” 。

(3) 第 31(3)條現予廢除，代以 —

“(3) Without prejudice to paragraph (3A) of this Article, a public transport aircraft registered outside Hong Kong, when making an instrument approach to an aerodrome –

- (a) if the relevant runway visual range at the aerodrome is at the time less than the specified minimum for landing, shall not continue the approach below 1 000 feet above the height of the aerodrome; or

(b) if the reported visibility or controlling runway visual range at the aerodrome falls below the specified minimum after the aircraft has descended below 1 000 feet above the height of the aerodrome, may continue the approach to –

(i) the decision altitude or decision height; or

(ii) the minimum descent altitude or minimum descent height.

(3A) Unless the specified visual reference for landing is established and maintained, a public transport aircraft registered outside Hong Kong shall not continue its approach to land at an aerodrome below –

(a) the decision altitude or decision height; or

(b) the minimum descent altitude or minimum descent height.”。

24. Pre-flight action by commander of aircraft

(1) 第 32 條的標題現予修訂，廢除 “**commander**” 而代以 “**pilot in command**”。

(2) 第 32 條現予修訂，廢除 “commander” 而代以 “pilot in command”。

(3) 第 32(b) 條現予廢除，代以 —

“(b) either —

(i) that the equipment (including radio apparatus) required by or under this Order to be carried in the circumstances of the intended flight is carried and is in a fit condition for use; or

(ii) that the flight may commence under and in accordance with the terms of a permission granted to the operator of the aircraft under Article 14A of this Order;”。

25. Pilots to remain at controls

(1) 第 33(1) 條現予修訂，廢除 “The commander” 而代以 “The pilot in command”。

(2) 第 33(1) 條現予修訂，廢除 “commander shall cause” 而代以 “pilot in command shall cause”。

(3) 第 33(1) 條現予修訂，廢除 “the public transport of passengers the commander” 而代以 “public transport, the pilot in command”。

26. Public transport of passengers – duties of commander

(1) 第 34 條的標題現予修訂，廢除 “**commander**” 而代以 “pilot in command”。

(2) 第 34(2)條現予修訂，廢除 “commander” 而代以 “pilot in command” 。

(3) 第 34(2)(b)(ii)條現予修訂，廢除 “cabin attendants” 而代以 “members of the cabin crew” 。

(4) 第 34(2)(e)條現予修訂，廢除 “before the aircraft takes-off, and before it lands” 而代以 “except as provided in paragraph (a) of the proviso to Article 45 of this Order, from the moment when, after the embarkation of passengers for the purpose of taking off, the aircraft first moves until after it has taken off, and before it lands and until it comes to rest for the purpose of disembarkation of passengers” 。

(5) 第 34(2)(e)(ii)條現予修訂，廢除 “secure” 而代以 “secured” 。

(6) 第 34(2)(g)條現予修訂，廢除 “millibars” 而代以 “hectopascals” 。

(7) 第 34(2)(g)(ii)條現予修訂，廢除 “cabin attendants” 而代以 “members of the cabin crew” 。

(8) 第 34(2)(h)條現予修訂，廢除 “millibars” 而代以 “hectopascals” 。

(9) 第 34(2)(h)(ii)條現予修訂，廢除 “cabin attendants” 而代以 “members of the cabin crew” 。

27. Operation of radio in aircraft

(1) 第 35(1)條現予廢除，代以 —

“(1) The radio station in an aircraft shall not be operated, whether or not the aircraft is in flight, except —

- (a) in accordance with the conditions of the licence issued in respect of that station under the law of –
 - (i) if there is no Article 83 bis transfer of the functions and duties under Article 30 of the Chicago Convention in respect of the aircraft, the country in which the aircraft is registered; or
 - (ii) if there is such a transfer, the state of the operator of the aircraft; and
- (b) by a person duly licensed or otherwise permitted to operate the radio station under the law of the country in which the aircraft is registered or of the state of that operator, as the case may be.”。

(2) 第 35(5)、(6)及(7)條現予廢除。

28. Minimum navigation performance

(1) 第 36 條現予修訂，將該條重編為第 36(1)條。

(2) 第 36(1)條現予修訂，廢除在“unless”之後的所有字句而代以“the aircraft is equipped with navigation systems which enable the aircraft to maintain the navigation performance capability prescribed under that Regulation.”。

(3) 第 36 條現予修訂，加入 —

“(2) The equipment that forms part of the navigation systems referred to in paragraph (1) of this Article shall —

(a) be approved by the Chief Executive;

(b) be installed, and maintained, in a manner approved by the Chief Executive; and

(c) be operated in accordance with the procedures approved by the Chief Executive while the aircraft is flying in that airspace.

(3) An approval granted by the Chief Executive for the purposes of this Article shall be in writing and may be subject to such conditions as the Chief Executive thinks fit.”。

29. 加入條文

現加入 —

“36A. **Area navigation and required navigation performance capabilities – aircraft registered in Hong Kong**

(1) An aircraft registered in Hong Kong shall not fly in designated required navigation performance airspace unless the aircraft is equipped with area navigation equipment that complies with paragraph (2) of this Article.

(2) The equipment shall —

- (a) enable the aircraft to maintain the navigation performance capability specified in respect of the airspace in which the aircraft is flying;
- (b) be approved by the Chief Executive;
- (c) be installed, and maintained, in a manner approved by the Chief Executive; and
- (d) be operated in accordance with the procedures approved by the Chief Executive while the aircraft is flying in designated required navigation performance airspace.

(3) An aircraft registered in Hong Kong that is not equipped with area navigation equipment that complies with paragraph (2) of this Article may fly in designated required navigation performance airspace only if the flight has been authorized by the appropriate air traffic control unit and the aircraft complies with the instructions given by the unit.

36B. Area navigation and required navigation performance capabilities – aircraft registered outside Hong Kong

(1) An aircraft registered outside Hong Kong shall not, if the law of the country in which the aircraft is registered requires the aircraft to be equipped with area navigation equipment that complies with paragraph (2) of this Article when flying within designated required navigation performance airspace, fly in designated required navigation performance airspace in Hong Kong unless the aircraft is so equipped.

(2) The equipment shall –

- (a) be capable of being operated so as to enable the aircraft to maintain the navigation performance capability specified in respect of the airspace in which the aircraft is flying; and
- (b) be so operated while the aircraft is flying in that airspace.

(3) An aircraft registered outside Hong Kong that is not equipped with area navigation equipment that complies with paragraph (2) of this Article may fly in designated required navigation performance airspace in Hong Kong only if the flight has been authorized by the appropriate air traffic control unit of Hong Kong and the aircraft complies with the instructions given by the unit.

**36C. Height keeping performance capabilities
– aircraft registered in Hong Kong**

(1) Unless authorized by the appropriate air traffic control unit, an aircraft registered in Hong Kong shall not fly in reduced vertical separation minimum airspace notified for the purposes of this Article unless the aircraft is equipped with height keeping systems that comply with paragraph (2) of this Article and that enable the aircraft to maintain the height keeping performance capability specified in Schedule 15 to this Order.

(2) The equipment that forms part of the height keeping systems referred to in paragraph (1) of this Article shall –

- (a) be approved by the Chief Executive;

- (b) be installed, and maintained, in a manner approved by the Chief Executive; and
- (c) be operated in accordance with the procedures approved by the Chief Executive while the aircraft is flying in that airspace.

**36D. Height keeping performance capabilities
– aircraft registered outside Hong Kong**

(1) An aircraft registered outside Hong Kong shall not, if the law of the country in which the aircraft is registered requires the aircraft to be equipped with height keeping systems that comply with paragraph (2) of this Article when flying in any specified area, fly in Hong Kong reduced vertical separation minimum airspace unless the aircraft is so equipped.

(2) The equipment that forms part of the height keeping systems referred to in paragraph (1) of this Article shall –

- (a) be capable of being operated so as to enable the aircraft to maintain the height keeping performance capability specified in respect of the airspace in which the aircraft is flying; and
- (b) be so operated while the aircraft is flying in that airspace.

(3) An aircraft registered outside Hong Kong that is not equipped with height keeping systems that comply with paragraph (2) of this Article may fly in Hong Kong reduced vertical separation minimum airspace only if the flight has been authorized by the appropriate air traffic control unit of Hong Kong and the aircraft complies with the instructions given by the unit.”。

30. Use of flight recording systems and preservation of records

- (1) 第 37(2)(a)條現予修訂，廢除“date”而代以“data”。
- (2) 第 37(4)(a)條現予修訂，廢除“8”而代以“10”。
- (3) 第 37(4)(b)(i)條現予修訂，廢除“eight”而代以“10”。
- (4) 第 37(4)(b)(ii)(bb)條現予修訂，在“cases”之後加入“or”。
- (5) 第 37(5)條現予修訂，廢除“eight”而代以“10”。
- (6) 第 37 條現予修訂，加入 —

“(7) A flight recorder shall be deactivated on completion of flight time following an accident as defined in regulation 2(1) of the Hong Kong Civil Aviation (Investigation of Accidents) Regulations (Cap. 448 sub. leg. B).

(8) A flight recorder deactivated pursuant to paragraph (7) of this Article shall not be reactivated before its disposition as determined by the investigation authority of the state conducting the investigation of the accident.

(9) If an aircraft becomes involved in an accident as referred to in paragraph (7) of this Article, the operator or pilot in command of the aircraft shall, to the extent possible, ensure that all related flight recorder records and if necessary, the associated flight recorders are preserved and retained in safe custody pending their disposition.

(10) In this Article, “flight recorder” means any of the recorders referred to in paragraphs (1), (2), (3) and (4) of this Article.” ◦

31. 加入條文

現加入 —

“37A. Use of airborne collision avoidance system

On any flight on which an airborne collision avoidance system is required by Article 14 of, and Schedule 6 to, this Order to be carried in an aeroplane, the system shall be operated —

- (a) in the case of an aeroplane to which Article 25 of this Order applies, in accordance with the procedures contained in the operations manual for the aeroplane;
- (b) in the case of an aeroplane registered in Hong Kong to which Article 25 of this Order does not apply, in accordance with the procedures that are suitable having regard to the purposes of the equipment that forms part of the system; or

- (c) in the case of an aeroplane registered outside Hong Kong, in accordance with the procedures that the aeroplane is required to comply with under the law of the country in which the aeroplane is registered.”。

32. Towing of gliders

(1) 第 38(1)條現予修訂，廢除 “law of the country in which that aircraft is registered includes” 而代以 —

“law of —

- (a) if there is no Article 83 bis transfer of the functions and duties under Article 31 of the Chicago Convention in respect of the towing aircraft, the country in which the towing aircraft is registered; or
- (b) if there is such a transfer, the state of the operator of the towing aircraft,

includes”。

(2) 第 38(3)條現予修訂，廢除 “The commander” 而代以 “The pilot in command”。

(3) 第 38(3)(b)條現予修訂，在未處加入 “and”。

(4) 第 38(3)(c)條現予修訂，廢除所有 “commander” 而代以 “pilot in command”。

33. Towing, picking up and raising of persons and articles

(1) 第 39(1)條現予修訂，廢除 “that aircraft under the law of the country in which the aircraft is registered includes” 而代以 —

“the aircraft under the law of —

(a) if there is no Article 83 bis transfer of the functions and duties under Article 31 of the Chicago Convention in respect of the aircraft, the country in which the aircraft is registered; or

(b) if there is such a transfer, the state of the operator of the aircraft,

includes” 。

(2) 第 39(7)(b)條現予修訂，廢除 “of saving life;” 而代以 —

“of —

(i) fire fighting or prevention;

(ii) life-saving or law enforcement operation; or

(iii) the training of the personnel engaged in the activities referred to in sub-subparagraph (i) or (ii) of this subparagraph;” 。

(3) 第 39(7)(c)條現予修訂，在未處加入 “or” 。

34. Dropping of animals and articles

(1) 第 40(2)條現予修訂，在但書中，廢除 “commander” 而代以 “pilot in command” 。

(2) 第 40(2)條現予修訂，在但書(a)段中，廢除 “of saving life;” 而代以 —

“of —

(i) fire fighting or prevention;

(ii) life-saving or law enforcement operation; or

(iii) the training of the personnel engaged in the activities referred to in sub-subparagraph (i) or (ii) of this subparagraph;” 。

(3) 第 40(3)條現予修訂，廢除 “dropping” 而代以 “, “dropping”” 。

(4) 第 40(4)條現予修訂，廢除 “law of the country in which it is registered includes” 而代以 —

“law of —

(a) if there is no Article 83 bis transfer of the functions and duties under Article 31 of the Chicago Convention in respect of the helicopter, the country in which the helicopter is registered; or

(b) if there is such a transfer, the state of the operator of the helicopter,

includes” 。

35. Dropping of persons

(1) 第 41(2)條現予修訂，廢除 “dropping” 而代以
“, “dropping”” 。

(2) 第 41(4)條現予修訂，廢除 “that aircraft under the law
of the country in which the aircraft is registered includes” 而
代以 —

“the aircraft under the law of —

- (a) if there is no Article 83 bis
transfer of the functions and
duties under Article 31 of the
Chicago Convention in respect of
the aircraft, the country in which
the aircraft is registered; or
- (b) if there is such a transfer, the
state of the operator of the
aircraft,

includes” 。

(3) 第 41(7)條現予修訂，廢除 “of saving life.” 而代以 —

“of —

- (a) fire fighting or prevention;
- (b) life-saving or law enforcement
operation; or

- (c) the training of the personnel engaged in the activities referred to in subparagraph (a) or (b) of this paragraph.”。

(4) 第 41(8)條現予修訂，廢除 “law of the country in which it is registered includes” 而代以 —

“law of —

- (a) if there is no Article 83 bis transfer of the functions and duties under Article 31 of the Chicago Convention in respect of the helicopter, the country in which the helicopter is registered; or
- (b) if there is such a transfer, the state of the operator of the helicopter,

includes”。

36. Carriage of weapons and of munitions of war

(1) 第 43(1)(b)條現予修訂，廢除 “commander or” 而代以 “pilot in command of”。

(2) 第 43(4)條現予修訂，廢除 “in a country other than” 而代以 “outside”。

37. Exits and break-in markings

(1) 第 46(2)條現予修訂，在但書(b)段中，廢除“commander”而代以“pilot in command”。

(2) 第 46(5)(b)條現予修訂，廢除“10 centimetres in length along its outer edge and 2.5 centimetres in width”而代以“9 cm in length along its outer edge and 3 cm in width, and if the corner markings are more than 2 m apart, intermediate lines of 9 cm by 3 cm shall be inserted so that adjacent markings are less than 2 m apart”。

(3) 第 46(8)條現予修訂，在但書(b)段中，廢除“No exit”而代以“No Exit”。

38. Imperilling safety of aircraft

第 47 條的標題現予修訂，廢除“**Imperilling**”而代以“**Endangering**”。

39. Imperilling safety of any person or property

第 48 條的標題現予修訂，廢除“**Imperilling**”而代以“**Endangering**”。

40. Drunkenness in aircraft

(1) 第 49 條的標題現予廢除，代以 —

“**Passengers and crew members not to be under influence of psychoactive substances**”。

(2) 第 49(1)條現予廢除，代以 —

“(1) A person shall not embark on an aircraft when under the influence of psychoactive substances, or be under the influence of psychoactive substances on board an aircraft, to such an extent as to jeopardize, or be likely to jeopardize —

(a) the safety of the aircraft or of persons or property on board the aircraft; or

(b) good order and discipline on board the aircraft.”。

(3) 第 49(2)條現予修訂，廢除 “drink or a drug” 而代以 “psychoactive substances”。

(4) 第 49 條現予修訂，加入 —

“(3) A holder of a licence granted under this Order authorizing the holder to act as a member of the crew of an aircraft shall not engage in the use of psychoactive substances in a way that —

(a) constitutes a direct hazard to the holder or endangers the lives, health or welfare of others; or

(b) causes or worsens an occupational, social, physical or mental problem or disorder of the holder.”。

41. Smoking in aircraft

(1) 第 50 條的標題現予廢除，代以 —

“Exhibition of notices indicating prohibition of smoking” 。

- (2) 第 50(2)條現予廢除。

42. Authority of commander of aircraft

(1) 第 51 條的標題現予修訂，廢除 “**commander**” 而代以 “**pilot in command**” 。

(2) 第 51 條現予修訂，廢除 “commander” 而代以 “pilot in command” 。

43. Stowaways

第 52 條現予修訂，廢除 “commander thereof” 而代以 “pilot in command of the aircraft” 。

44. Fatigue of crew – responsibilities of crew

第 55(1)條現予修訂，在 “suspects” 之前加入 “reasonably” 。

45. Records to be kept

(1) 第 58 條現予修訂，將該條重編為第 58(1)條。

(2) 第 58(1)條現予修訂 —

(a) 廢除 “in a manner prescribed” ；

(b) 廢除 “the flight.” 而代以 “the flight, unless the Chief Executive otherwise directs.” 。

(3) 第 58 條現予修訂，加入 —

“(2) The operator of a public transport aircraft registered in Hong Kong shall, in respect of any flight by the aircraft during which it may fly at an altitude of more than 26 000 feet, keep a record of the total dose of cosmic radiation to which the members of the crew of the aircraft are exposed during the flight and of the names of such members so that the total cosmic radiation dose received by each member of the crew over a period of 12 consecutive months can be determined, unless the Chief Executive otherwise directs.”。

46. Production of documents and records

第 59(1)條現予修訂，廢除 “commander” 而代以 “pilot in command” 。

47. Preservation of documents, etc.

(1) 第 61 條現予修訂，在但書(a)段中，廢除 “he” 而代以 “, the first-mentioned operator” 。

(2) 第 61 條現予修訂，在但書(b)段中，廢除 “he” 而代以 “, the first-mentioned operator” 。

(3) 第 61 條現予修訂，在但書(c)段中 —

(a) 廢除 “him” 而代以 “the first-mentioned operator” ；

(b) 廢除 “registered in Hong Kong and operated by another person he” 而代以 “that is registered in Hong Kong and operated by a person other than the first-mentioned operator, the first-

mentioned operator”。

48. Revocation, suspension and variation of certificates, licences and other documents

第 62(1)條現予修訂，廢除“licence approval”而代以“licence, approval”。

49. Rules of the air

(1) 第 64 條的標題現予修訂，廢除“air”而代以“Air”。

(2) 第 64(3)(c)條現予修訂，廢除“commander”而代以“pilot in command”。

(3) 第 64(4)條現予修訂，廢除“commander”而代以“pilot in command”。

50. Provision of air traffic services

(1) 第 64A(2)條現予修訂，廢除“radar”而代以“air traffic service surveillance system”。

(2) 第 64A(3)條現予修訂，廢除“aerodrome flight”而代以“flight”。

51. Licensing of air traffic controllers, student air traffic controllers and aerodrome flight information service officers

(1) 第 65 條的標題現予修訂，廢除“， student air traffic controllers and aerodrome flight information service officers”

而代以 “**and student air traffic controllers**” 。

(2) 第 65(1)條現予修訂 —

(a) 廢除 “, as a student air traffic controller or as an aerodrome flight information service officer” 而代以 “or a student air traffic controller” ；

(b) 在 “skill,” 之後加入 “language ability, and” 。

(3) 第 65(1)條現予修訂，在但書(a)段中 —

(a) 廢除 “or an aerodrome flight information service officer’s licence” ；

(b) 廢除 “18” 而代以 “21” 。

(4) 第 65(1)條現予修訂，在但書(b)段中，廢除在 “includes” 之後的所有字句而代以 “ratings of classes as set out in Schedule 10 to this Order to a person under the age of 21 years.” 。

(5) 第 65(1)條現予修訂，廢除但書(c)段。

(6) 第 65(2)條現予修訂，廢除 “radar equipment” 而代以 “air traffic service surveillance system” 。

(7) 第 65(4)條現予廢除。

(8) 第 65(5)條現予修訂，廢除在 “an air traffic controller” 之後的所有字句而代以 “or a student air traffic controller shall not be valid unless it bears the ordinary signature of the holder of the licence in ink.” 。

(9) 第 65(6)條現予修訂，廢除 “, as a student air traffic controller or as an aerodrome flight information service officer” 而代以 “or a student air traffic controller” 。

(10) 第 65(7)(b)條現予修訂，廢除 “and skill” 而代以 “, skill and language ability” 。

(11) 第 65(8)條現予廢除。

(12) 第 65 條現予修訂，加入 —

“(9A) The Chief Executive may include in a licence granted under this Article an endorsement in respect of language proficiency, subject to such conditions as he thinks fit, on his being satisfied that the licence holder has demonstrated the ability to speak and understand the language used for radiotelephony communications in the provision of air traffic control service or flight information service.

(9B) The endorsement referred to in paragraph (9A) of this Article shall be valid for the period specified in the licence.” 。

(13) 第 65(10)條現予修訂 —

(a) 在 “control service” 之後加入 “or flight information service” ；

(b) 廢除在 “his” 之後的所有字句而代以 —

“licence —

(a) includes a valid medical certificate issued under paragraph (9) of this Article; and

(b) bears a valid language proficiency endorsement referred to in paragraph (9A)

of this Article and the conditions subject to which the endorsement was made are complied with.”。

52. Prohibition of unlicensed air traffic controllers, student air traffic controllers and aerodrome flight information service officers

(1) 第 66 條的標題現予修訂，廢除 “, **student air traffic controllers and aerodrome flight information service officers**” 而代以 “**and student air traffic controllers**”。

(2) 第 66(1)條現予修訂，廢除兩度出現的 “or an aerodrome flight information service” 而代以 “or flight information service”。

(3) 第 66(1)(b)條現予修訂 —

(a) 廢除 “case of an aerodrome” 而代以 “case of a” ；

(b) 廢除 “aerodrome flight information service officer’s licence” 而代以 “air traffic controller’s licence”。

(4) 第 66(2)(a)條現予修訂，廢除 “radar equipment” 而代以 “air traffic service surveillance system”。

(5) 第 66(3)條現予修訂，廢除 “an aerodrome”。

(6) 第 66(4)條現予廢除。

(7) 第 66 條現予修訂，加入 —

“(6) Nothing in this Article shall prohibit a person approved by an authorized person for the

purposes of this paragraph from relaying any air traffic control instruction or flight information when directed to do so by a holder of a valid air traffic controller's licence with the appropriate rating which entitles the holder to give the instruction or information, as the case may be.” ◦

53. 取代條文

第 67 條現予廢除，代以 —

“67. Manual of Air Traffic Control

(1) A person who provides an air traffic service in Hong Kong with the approval of the Chief Executive under Article 64A of this Order shall issue and maintain an up-to-date manual of air traffic control.

(2) If the Chief Executive so requires, the manual of air traffic control referred to in paragraph (1) of this Article shall be amended and produced to the Chief Executive.

(3) An air traffic controller and a student air traffic controller shall, when providing an air traffic control service or a flight information service, comply with the standards and procedures specified in the manual of air traffic control referred to in paragraph (1) of this Article.” ◦

54. Incapacity of air traffic controllers

第 68(3)條現予廢除，代以 —

“(3) The holder of an air traffic controller's licence who has reason to believe that she is pregnant

shall not be entitled to exercise the privileges of her licence and ratings unless –

- (a) obstetrical evaluation and continued medical assessment indicate that her pregnancy is a low-risk uncomplicated pregnancy; and
- (b) she has undergone such medical examination as an authorized person may reasonably require for the purpose of ascertaining whether she is medically fit to exercise those privileges and the result of the examination shows that she is able to safely exercise those privileges.

(4) The holder of an air traffic controller’s licence shall not, after her confinement or the termination of her pregnancy, be entitled to exercise the privileges of her licence and ratings until she has undergone the medical examination referred to in paragraph (3)(b) of this Article and the result of the examination shows that she is able to safely exercise those privileges.” ◦

55. 加入條文

現加入 —

“68A. Air traffic controllers not to exercise privileges of licences or use psychoactive substances in certain circumstances

(1) The holder of an air traffic controller’s licence –

- (a) shall not exercise the privileges of his licence if he knows or reasonably suspects that his physical or mental condition renders him unfit to exercise such privileges; and
- (b) shall not, when exercising the privileges of the licence, be under the influence of psychoactive substances which may render him unable to safely and properly exercise such privileges.

(2) The holder of an air traffic controller's licence shall not engage in the use of psychoactive substances in a way that –

- (a) constitutes a direct hazard to the holder or endangers the lives, health or welfare of others; or
- (b) causes or worsens an occupational, social, physical or mental problem or disorder of the holder.

**68B. Fatigue of air traffic controller –
air traffic controller's
responsibilities**

The holder of an air traffic controller's licence shall not exercise the privileges of his licence if he knows or reasonably suspects that he is suffering from, or having regard to the circumstances of the period of duty to be undertaken is likely to suffer from, such fatigue as may endanger the safety of any aircraft or of the occupants of any aircraft.” °

56. Power to prohibit or restrict flying

(1) 第 69(2)條現予修訂，廢除“commander”而代以“pilot in command”。

(2) 第 69(3)條現予修訂，廢除“commander”而代以“pilot in command”。

57. Balloons, kites, airships, gliders and parascending parachutes

第 70(1)(f)條現予修訂，廢除“which”而代以“winch”。

58. Aerodromes: public transport of passengers and instruction in flying

第 71(2)(c)條現予修訂，廢除“，(ii)”。

59. Aeronautical radio stations

(1) 第 74(2)條現予修訂，廢除“radar”而代以“air traffic service surveillance system”。

(2) 第 74(2)條現予修訂，在但書中，廢除“of an aircraft and the commander thereof”而代以“and the pilot in command of an aircraft”。

60. Aeronautical radio station records

第 75(1)條現予修訂，廢除“radar”而代以“air traffic service surveillance system”。

61. Aeronautical lights

第 79(1)條現予修訂，廢除“of;”而代以“of –”。

62. Flights over any place outside Hong Kong

(1) 第 85(1)條現予修訂，廢除“commander”而代以“pilot in command”。

(2) 第 85(3)條現予修訂，廢除“commander”而代以“pilot in command”。

63. Mandatory reporting

(1) 第 86(1)(a)條現予廢除，代以 —

“(a) is the operator or the pilot in command of —

(i) a turbine-powered aircraft in respect of which there is in force a certificate of airworthiness issued by the Chief Executive; or

(ii) an aircraft, whether registered in Hong Kong or elsewhere, operated by a holder of an air operator’s certificate granted by the Chief Executive; or”。

(2) 第 86(2)條現予修訂，在但書中，廢除在“that”之後的所有字句而代以“an accident in respect of which notice has been given to the Chief Inspector pursuant to the Hong Kong Civil Aviation (Investigation of Accidents) Regulations (Cap. 448 sub. leg. B) shall not constitute a reportable occurrence for the purposes of this Article.”。

(3) 第 86 條現予修訂，加入 —

“(6) In this Article, “Chief Inspector” has the meaning assigned to it by regulation 2(1) of the Hong Kong Civil Aviation (Investigation of Accidents) Regulations (Cap. 448 sub. leg. B).”。

64. Power to prevent aircraft flying

(1) 第 87(1)條現予修訂，廢除 “commander” 而代以 “pilot in command”。

(2) 第 87(3)條現予修訂，廢除 “commander” 而代以 “pilot in command”。

65. Penalties

第 91(1)條現予修訂，廢除 “of that aircraft and the commander thereof” 而代以 “and the pilot in command of that aircraft”。

66. Application of Order to Chinese controlled aircraft not registered in Hong Kong

第 93 條的標題現予修訂，廢除 “Chinese controlled aircraft not registered in” 而代以 “aircraft registered outside”。

67. Appeal to High Court

(1) 第 96(1)條現予修訂 —

(a) 廢除 “a licence to act as an aircraft maintenance engineer,” 而代以 “an aircraft

maintenance licence or a licence to act as a” ；

(b) 廢除 “, student air traffic controller or aerodrome flight information service officer” 而代以 “or student air traffic controller” 。

(2) 第 96(1)條現予修訂，在但書中，在 “skill,” 之後加入 “language ability or” 。

68. Interpretation

(1) 第 98(1)條現予修訂，廢除 “Aerodrome flight information unit” 的定義。

(2) 第 98(1)條現予修訂，廢除 “Aerodrome traffic zone” 的定義而代以 —

““Aerodrome traffic zone”, in relation to an aerodrome, means the airspace —

(a) which is in the vicinity of the aerodrome that is notified for the purposes of Rule 35 of Schedule 14 to this Order; and

(b) which is of defined dimensions established around the aerodrome for the protection of aerodrome traffic;” 。

(3) 第 98(1)條現予修訂，廢除 “Commander” 的定義。

(4) 第 98(1)條現予修訂，在 “Decision height” 的定義中，廢除 “establish” 而代以 “established” 。

(5) 第 98(1)條現予修訂，在“Flight level”的定義中，廢除“millibars”而代以“hectopascals”。

(6) 第 98(1)條現予修訂，在“Minimum descent height”的定義中，廢除“may”而代以“must”。

(7) 第 98(1)條現予修訂，廢除“Pilot in command”的定義而代以 —

““Pilot in command”, in relation to an aircraft, means the pilot designated by the operator or the owner, as appropriate, as being in charge of the aircraft without being under the direction of any other pilot in the aircraft and charged with the safe conduct of a flight;”。

(8) 第 98(1)條現予修訂，在“Runway visual range”的定義中，廢除“commander”而代以“pilot in command”。

(9) 第 98(1)條現予修訂，在“Special VFR flight”的定義中，廢除在“flight”之後的所有字句而代以“has the meaning assigned to it by Rule 23 of the Rules of the Air;”。

(10) 第 98(1)條現予修訂，加入 —

““Aeroplane” means a power-driven heavier-than-air aircraft, deriving its lift in flight chiefly from aerodynamic reactions on surfaces which remain fixed under given conditions of flight;

“Air traffic service surveillance system” means automatic dependent surveillance – broadcast, primary surveillance radar, secondary surveillance radar or any comparable ground-based system that enables the identification of aircraft;

“Aircraft” means a machine that can derive support in the atmosphere from the reactions of the air other than the reactions of the air against the earth’s surface;

“Area navigation equipment” means equipment carried on board an aircraft which enables the aircraft to navigate on any desired flight path within the coverage of appropriate ground based navigation aids or within the limits of the equipment or a combination of the two;

“Article 83 bis transfer”, in relation to an aircraft, means a transfer under Article 83 bis of the Chicago Convention of all or part of the functions and duties under Articles 12, 30, 31 and 32 a) of the Convention in respect of the aircraft;

“Cabin crew”, in relation to an aircraft, means those crew members assigned by the operator or pilot in command of the aircraft to perform, in the interests of the safety of passengers, duties on board the aircraft but does not include members of the flight crew;

“Captive balloon” means a balloon which when in flight is attached by a restraining device to the surface;

“Decision altitude”, in relation to the operation of an aircraft at an aerodrome, means the altitude in a precision approach at which a missed approach must be initiated if the required visual reference to continue that approach has not been established;

“Designated required navigation performance airspace” means airspace that has been notified, prescribed or otherwise designated by the competent authority for the airspace in respect of which an aircraft is required to meet the specified navigation performance capabilities when flying in or over the airspace;

“Flight information service” means a service that is provided for the purposes of giving advice and information useful for the safe and efficient conduct of flights;

“Free balloon” means a balloon which when in flight is not attached by any form of restraining device to the surface;

“Helicopter” means a heavier-than-air aircraft supported in flight chiefly by the reactions of the air on one or more power-driven rotors on substantially vertical axes;

“Microlight aeroplane” means an aeroplane designed to carry not more than 2 persons that has –

(a) a maximum total weight authorized not exceeding –

(i) in the case of a single seat landplane, 300 kg;

(ii) in the case of a 2 seats landplane, 450 kg;

(iii) in the case of a single seat amphibian or floatplane, 330 kg; or

(iv) in the case of a 2 seats amphibian or floatplane, 495 kg; and

(b) a stalling speed at the maximum total weight authorized not exceeding 35 knots calibrated airspeed;

“Minimum descent altitude”, in relation to the operation of an aircraft at an aerodrome, means the altitude in a non-precision approach below which descent must not be made without the required visual reference;

“Private flight” means a flight which is not used for the purpose of aerial work or public transport;

“Psychoactive substances” means alcohol, opioids, cannabinoids, sedatives, hypnotics, cocaine or other psychostimulants, hallucinogens or volatile solvents, but does not include coffee and tobacco;

“State of the operator” means the state in which the operator of an aircraft has –

(a) his principal place of business; or

(b) if he has no such place of business, his permanent residence;” °

(11) 第 98(3)(c)條現予修訂 —

(a) 廢除 “or free balloon” ；

(b) 廢除 “thereto or comes to rest thereon” 而代以
“to the surface or comes to rest on the
surface” 。

(12) 第 98(3)條現予修訂，加入 —

“(d) in the case of a free balloon, from the moment
when the balloon, including the canopy and
basket, becomes separated from the surface
until the moment when it next comes to rest on
the surface; or

(e) in the case of a captive balloon, from the
moment when the balloon, including the canopy
and basket but excluding the restraining
device that attaches the balloon to the
surface, becomes separated from the surface
until the moment when it next comes to rest on
the surface;” 。

(13) 第 98(4)條現予修訂，廢除 “employed or engaged in an
aircraft in flight on the business of the aircraft” 而代以
“assigned by the operator of an aircraft to be involved in the
operation of the aircraft during any portion of a flight” 。

(14) 第 98(6)(a)(ii)條現予修訂，廢除 “aricraft” 而代以
“aircraft” 。

(15) 第 98(6)(a)(iii)條現予修訂，廢除 “hire-purchase” 而代
以 “hire-purchase agreement” 。

69. 加入條文

現加入 —

“102. Safety management system

- (1) A person, other than a natural person, who –
- (a) is the operator of an aircraft registered in Hong Kong that is flown for the purposes of public transport;
 - (b) issues a certificate of release to service in respect of the aircraft referred to in subparagraph (a) of this paragraph, or of any equipment or part of the aircraft;
 - (c) provides an air traffic service; or
 - (d) is an aerodrome licence holder,

shall, in respect of the activities that he is authorized, permitted, approved or required to carry out under this Order, implement a safety management system that –

- (e) complies with paragraphs (2) and (3) of this Article; and
 - (f) is accepted by the Chief Executive.
- (2) The safety management system shall –
- (a) identify safety hazards and manage associated risks;

- (b) ensure that remedial action necessary to maintain an acceptable level of safety is carried out;
- (c) provide for continuous monitoring and regular assessment of the safety level achieved;
- (d) aim to make continuous improvement to the overall level of safety; and
- (e) be appropriate to the size, nature and complexity of the activities concerned and the safety hazards and risks related to such activities.

(3) The safety management system shall be a documented system and shall contain the following elements –

- (a) explicit safety policies on which the system is based;
- (b) safety objectives and performance targets and indicators;
- (c) clearly defined lines of safety accountabilities and responsibilities of staff at all levels;
- (d) promotion of safety culture;
- (e) safety training to ensure competence of staff;
- (f) monitoring and reviewing of safety performance of staff;

- (g) safety management and oversight procedures;
- (h) collection and analysis of safety information and data with the aim of preventing adverse safety trend;
- (i) maintenance and, where appropriate, sharing of safety information and data;
- (j) a contingency and emergency response plan;
- (k) investigation of accidents and occurrences of significant nature with a view to identifying and implementing safety improvement measures;
- (l) periodic reviews, audits and inspections of the systems and procedures established in relation to the elements referred to in this paragraph.”。

70. 修訂附表 1

(1) 附表 1 現予修訂，廢除在開首處的“Article 4(6), 23(2) and 99(8)”而代以“Articles 4(6) and (8), 5(2), 23(2) and 98(8)”。

(2) 附表 1 的 A 部的表的第 2 欄現予修訂 —

- (a) 廢除“Lighter than air”而代以“Lighter-than-air”；
- (b) 廢除“Heavier than air”而代以“Heavier-than-air”。

(3) 附表 1 的 A 部的表的第 4 欄現予修訂，在 —

“Aeroplane (Self-launching motor glider)”

之後加入 —

“Powered Lift (Tilt Rotor)”。

(4) 附表 1 的 B 部第 4(a)項現予修訂，廢除 “an aeroplane having an empty weight not exceeding 150 kg” 而代以 “a microlight aeroplane,”。

(5) 附表 1 的 B 部第 5 項第 I 條 (a)段現予修訂，廢除 “Flying Machines and Gliders” 而代以 “Heavier-than-air aircraft”。

(6) 附表 1 的 B 部第 5 項第 I 條 (a) (i) (bb)段現予修訂，廢除 “15” 而代以 “30”。

(7) 附表 1 的 B 部第 5 項第 I 條 (b)段現予廢除，代以 —

“(b) Lighter-than-air aircraft

(i) Airships: The marks shall appear either on the hull, or on the stabilizer surfaces. Where the marks appear on the hull, they shall be located lengthwise on each side of the hull and also on its upper surface on the line of symmetry. Where the marks appear on the stabilizer surfaces, they shall appear on the horizontal and on the vertical stabilizers; the marks on the horizontal stabilizer shall be located on the right half of the upper surface and on the left half of the lower surface, with the tops of the letters towards the leading edge; the marks on the vertical stabilizer

shall be located on each side of the bottom half stabilizer, with the letters placed horizontally.

- (ii) Spherical balloons (other than unmanned free balloons): The marks shall appear in 2 places diametrically opposite. They shall be located near the maximum horizontal circumference of the balloon.
- (iii) Non-spherical balloons (other than unmanned free balloons): The marks shall appear on each side. They shall be located near the maximum cross-section of the balloon immediately above either the rigging band or the points of attachment of the basket suspension cables.
- (iv) Lighter-than-air aircraft (other than unmanned free balloons): The side marks shall be visible both from the sides and from the ground.
- (v) Unmanned free balloons: The marks shall appear on the fireproof metal plate mentioned in item 4 of this Part.”。

(8) 附表 1 的 B 部第 5 項第 II 條 (a) 段現予修訂，廢除 “Flying Machines and Gliders” 而代以 “Heavier-than-air aircraft” 。

(9) 附表 1 的 B 部第 5 項第 II 條 (b) 段現予修訂，廢除 “Airships and Free Balloons” 而代以 “Lighter-than-air aircraft” 。

(10) 附表 1 的 B 部第 5 項第 III 條(a)段現予廢除，代以 —

“(a) The width of each letter (except the letters I, M and W) and the length of the hyphen between the nationality mark and registration mark shall be two-thirds of the height of a letter. The width of the letter I shall be one-sixth of the height of the letter. The width of the letters M and W shall be neither less than two-thirds of their height nor more than their height.”。

(11) 附表 1 的 B 部第 5 項第 III 條(c)段現予修訂，廢除 “by a space equal to half” 而代以 “, by a space of not less than one-quarter of”。

71. 取代附表 2

附表 2 現予廢除，代以 —

“SCHEDULE 2 Articles 3(1),
5(3), 7(1A)
and 39(7)

A AND B CONDITIONS

The A and B Conditions referred to in Articles 3(1), 5(3), 7(1A) and 39(7) of this Order are as follows -

A Conditions

(1) The aircraft is an aircraft registered in Hong Kong and flies for a purpose set out in paragraph (2) of these Conditions when either -

- (a) it does not have a certificate of airworthiness issued or rendered valid under the law of Hong Kong; or
- (b) the certificate of airworthiness or certificate of validation issued in respect of the aircraft has ceased to be in force by virtue of any of the matters specified in Article 8(7) of this Order.

(2) The purposes referred to in paragraph (1) of these Conditions are as follows -

- (a) in the case of an aircraft falling within paragraph (1)(a) of these Conditions, enabling it to -
 - (i) qualify for the issue or renewal of a certificate of airworthiness or a certificate of validation after an application has been made for such issue or renewal, as the case may be;
 - (ii) carry out a functional check of a modification which has previously been approved by the Chief Executive in respect of that aircraft or another aircraft of the same type (“previously approved modification”);
 - (iii) proceed to or from a place at which any inspection, repair, modification, maintenance, approval, test or weighing of,

or the installation of equipment in, the aircraft is to take place or has taken place for a purpose referred to in subparagraph (i) or (ii) of this subparagraph after any relevant application has been made, or at which the installation of furnishings in, or the painting of, the aircraft is to be undertaken; or

(iv) proceed to or from a place at which the aircraft is to be or has been stored;

(b) in the case of an aircraft falling within paragraph (1)(b) of these Conditions, enabling it to -

(i) proceed to a place at which any inspection or maintenance as provided in Article 8(7)(b)(iv) of this Order is to take place;

(ii) proceed to a place at which any inspection, maintenance or modification as provided in Article 8(7)(b)(iii) or (c) of this Order is to take place and in respect of which flight the Chief Executive has given permission in writing; or

(iii) carry out a functional check, test or in-flight adjustment in connection with the carrying out in a manner approved by the

Chief Executive of any overhaul, repair, previously approved modification, inspection or maintenance as provided in Article 8(7)(a), (b) or (c) of this Order.

(3) The aircraft, including any modifications, is of a design which has previously been approved by the Chief Executive as being compliant with a standard accepted by the Chief Executive as appropriate for the issue of a certificate of airworthiness.

(4) The aircraft and its engines are certified as fit for flight -

(a) by the holder of an aircraft maintenance licence granted under this Order, being a licence which entitles him to issue that certificate; or

(b) by a person approved by the Chief Executive for the purpose of issuing certificates under this paragraph and in accordance with that approval.

(5) The aircraft carries the minimum flight crew specified in any certificate of airworthiness or certificate of validation or flight manual which has previously been in force under this Order in respect of the aircraft, or is or has previously been in force in respect of any other aircraft of identical design.

(6) The aircraft does not carry any persons or cargo except persons performing duties in the aircraft in connection with the flight or persons who are carried in the aircraft to perform duties in connection with a purpose set out in paragraph (2) of these Conditions.

(7) The aircraft does not fly over any congested area of a city, town or settlement except to the extent that it is necessary to do so in order to take off or land.

B Conditions

(1) The aircraft flies for a purpose set out in paragraph (2) of these Conditions whether or not it is registered as described in Article 3(1) of this Order and when there is not in force in respect of the aircraft -

- (a) in the case of an aircraft which is so registered, a certificate of airworthiness issued or rendered valid under the law of the country in which the aircraft is registered; or
- (b) in the case of an aircraft which is not so registered, either a certificate of airworthiness issued or rendered valid by the Chief Executive or a permit to fly issued by the Chief Executive.

(2) The purposes referred to in paragraph (1) of these Conditions are as follows -

- (a) experimenting with or testing the aircraft (including any engines installed in or on the aircraft) or any equipment installed in or carried in the aircraft;
- (b) enabling it to qualify for -

- (i) the issue of a certificate of airworthiness or a certificate of validation;
 - (ii) the approval of a modification of the aircraft; or
 - (iii) the issue of a permit to fly;
- (c) demonstrating and displaying the aircraft, any engines installed in or on the aircraft or any equipment installed in or carried in the aircraft with a view to the sale of the aircraft, engines or equipment or of other similar aircraft, engines or equipment;
- (d) demonstrating and displaying the aircraft to employees of the operator;
- (e) giving flying training to or testing flight crew employed by the operator who are carried or are intended to be carried pursuant to paragraph (7)(a) of these Conditions or training or testing other persons employed by the operator who are carried or are intended to be carried pursuant to paragraph (7)(a) of these Conditions; or
- (f) proceeding to or from a place at which any experiment, inspection, repair, modification, maintenance, approval, test or weighing of, or the installation of equipment in the aircraft, demonstration, display or training is to take place for a purpose referred to in subparagraphs (a), (b), (c), (d) or (e)

of this paragraph or at which the installation of furnishings in, or the painting of, the aircraft is to be undertaken.

(3) The flight is operated by a person approved by the Chief Executive for the purposes of these Conditions and subject to any additional conditions which may be specified in such an approval.

(4) If the aircraft is not registered in Hong Kong -

(a) it is marked in a manner approved by the Chief Executive for the purposes of these Conditions; and

(b) Articles 14, 15, 32, 35, 57 and 59 of this Order are complied with in relation to the aircraft as if it were registered in Hong Kong.

(5) If the aircraft is not registered in Hong Kong, it carries such flight crew as may be necessary to ensure the safety of the aircraft.

(6) No person acts as pilot in command of the aircraft except a person approved for the purposes of these Conditions by the Chief Executive.

(7) The aircraft does not carry any cargo or any persons other than the flight crew except the following -

(a) persons employed by the operator who during the flight carry out duties or are tested or receive training in connection with a purpose set out in paragraph (2) of these Conditions;

- (b) persons acting on behalf of a manufacturer of a component part of the aircraft (including its engines) or of equipment installed in or carried in the aircraft who during the flight carry out duties in connection with a purpose of the flight (being a purpose set out in paragraph (2) of these Conditions) that is relevant to the component part or equipment;
- (c) persons approved by the Chief Executive under Article 101 of this Order as qualified to furnish reports for the purposes of Article 8(8) of this Order;
- (d) persons other than those carried under the preceding provisions of this paragraph who are carried in the aircraft in order to carry out a technical evaluation of the aircraft or its operation;
- (e) cargo which comprises equipment carried in connection with the purpose set out in paragraph (2)(f) of these Conditions; or
- (f) persons employed by the operator or a person acting on behalf of a manufacturer of a component part of the aircraft (including its engines) or of equipment installed in or carried in the aircraft in connection with the purpose set out in paragraph (2)(f) of these Conditions who carry out duties in connection with that purpose.

(8) The aircraft does not fly, except in accordance with procedures which have been approved by the Chief Executive in relation to that flight, over any congested area of a city, town or settlement.”。

72. Categories of Aircraft

附表 3 現予修訂，廢除在開首處的“Article 3”而代以“Article 8(2)”。

73. Aerodrome Manual

附表 4 現予修訂 —

- (a) 在第(xviii)段中，廢除末處的“and”；
- (b) 在第(xix)段中，廢除句號而代以“; and”；
- (c) 加入 —

“(xx) the system of managing safety in an organized and orderly approach at the aerodrome.”。

74. Aircraft Equipment

(1) 附表 5 現予修訂，廢除在開首處的“and 13(2)”而代以“，13(2) and (8), 25(5) and 37(1), (3) and (4) and Schedule 11”。

(2) 附表 5 第 3(m)段現予修訂，廢除“Y1 and Y2”而代以“Y”。

(3) 附表 5 第 4 段現予修訂，在“TABLE”的標題之後加入 —

“For the purposes of this paragraph, “day” means the time from half an hour before sunrise until half an hour after sunset (both times exclusive), sunrise and sunset being determined at surface level.”。

(4) 附表 5 第 4 段的表現予修訂，在第(2)(a)段中，在第三欄中，廢除“A(i) and (ii) and B(i)”而代以“A(i), (ii) and (iii)(a) and B(i)”。

(5) 附表 5 第 4 段的表現予修訂，在第(2)(a)(i)段中，在第三欄中，廢除“C and D”而代以“C, E, F and G”。

(6) 附表 5 第 4 段的表現予修訂，在第(2)(a)段中，加入 —

| | |
|---|-------------------------------|
| “ (iv) when flying under Visual Flight Rules | |
| (aa) outside controlled airspace. | E(iv), F(i) and (vi) and FF |
| (bb) within controlled airspace. | E with E(iv) duplicated and F |
| (v) on all flights which involve manoeuvres on water. | H and J(iii) and (iv) |
| (vi) in the case of a single-engined aeroplane, when flying over water beyond gliding distance from land. | H |

- | | |
|--|-------------------------|
| <p>(vii) when flying over water at a distance of more than 50 nautical miles away from land suitable for making an emergency landing.</p> | <p>H</p> |
| <p>(viii) when flying over water</p> <p style="padding-left: 40px;">(aa) in the case of a single-engined aeroplane, when more than 100 nautical miles away from land suitable for making an emergency landing.</p> <p style="padding-left: 40px;">(bb) in the case of a multi-engined aeroplane capable of continuing flight with one engine inoperative, when more than 200 nautical miles away from land suitable for making an emergency landing.</p> | <p>K(i)</p> <p>K(i)</p> |
| <p>(ix) when flying over land areas which have been designated by the State concerned as areas in which search and rescue would be especially difficult where, in the event of an emergency landing, tropical conditions are likely to be met.</p> | <p>U</p> |

(x) when flying over land areas which have been designated by the State concerned as areas in which search and rescue would be especially difficult where, in the event of an emergency landing, polar conditions are likely to be met. V

(xi) when flying at a height of 10 000 ft or more above mean sea level. L2” 。

(7) 附表 5 第 4 段的表現予修訂，廢除第(2)(b)(iii)段而代以 —

“(iii) (aa) when flying over water at a distance of more than 50 nautical miles away from the shore, in the case of an aeroplane:

(aaa) in the event of the critical power unit becoming inoperative at any point along the route or planned diversions from that point, it shall be able to continue the

flight to an aerodrome at which landing can be made, without flying below the minimum flight altitude at any point; or

H

(*bbb*) having 3 or more power units, on any part of a route where the location of en-route alternate aerodrome and the total duration of the flight are such that the probability of a second power unit becoming inoperative must be allowed for if the general level of safety is to be maintained, it shall be able, in the event of any 2 power units becoming inoperative, to continue the

| | |
|---|------|
| flight to an en-route alternate aerodrome and land. | H |
| (bb) in the case of all other aeroplanes, when flying en-route over water beyond gliding distance from land. | H” 。 |

(8) 附表 5 第 4 段的表現予修訂，在第(2)段中，在第二欄中，廢除 (b)(v)(aa)(bbb)節而代以 —

“(bbb) having no performance group classification in its certificate of airworthiness and of such a weight and performance that with any one of its power units inoperative and the remaining power unit or units operating within the maximum continuous power conditions specified in the certificate of airworthiness, performance schedule or flight manual relating to the aeroplane issued or rendered valid by the Chief Executive it is capable of a gradient of climb of at least 1 in 200 at an altitude of 5 000 ft in the International Standard Atmosphere specified in or ascertainable by reference to the certificate of airworthiness in force in respect of that aircraft,

when either more than 400 nautical miles or more than 90 minutes flying time* from the nearest aerodrome at which an emergency landing can be made.” 。

(9) 附表 5 第 4 段的表現予修訂，在第(2)(b)(v)(bb)段中，在第二欄中，在“when”之後加入“either more than 100 nautical miles or”。

(10) 附表 5 第 4 段的表現予修訂，在第(2)(b)(xi)段中，在第三欄中，廢除“Y2(i)”而代以“Y(i)”。

(11) 附表 5 第 4 段的表現予修訂，在第(2)(b)(xii)段中，在第三欄中，廢除“R2”而代以“R”。

(12) 附表 5 第 4 段的表現予修訂，在第(2)(b)段中，加入 —

| | |
|---|-------------------------------|
| “(xvi) when flying under Visual Flight Rules: | |
| (aa) outside controlled airspace. | E(iv), F(i) and (vi) and FF |
| (bb) within controlled airspace. | E with E(iv) duplicated and F |
| (xvii) when operated by a single pilot under the Instrument Flight Rules or at night. | ZZ”。 |

(13) 附表 5 第 4 段的表現予修訂，在第(6)段中，在第一欄中，廢除(c)節而代以 —

“(c) for which an individual certificate of airworthiness was first issued (whether in Hong Kong or elsewhere) on or after 1 June 1990 and which have a maximum total weight authorized exceeding 27 000 kg:

Provided that this paragraph shall not apply to aeroplanes falling within paragraph (6A).”。

(14) 附表 5 第 4 段的表現予修訂，加入 —

| | | |
|---|-----------------------------------|------------------|
| <p>(6A) Aeroplanes in respect of which there is in force a certificate of airworthiness in the Transport Category (Passenger) or Transport Category (Cargo) and for which an individual certificate of airworthiness was first issued (whether in Hong Kong or elsewhere) on or after 1 January 2005 and which have a maximum total weight authorized exceeding 5 700 kg.</p> | <p>when flying on any flight.</p> | <p>S(viii)”。</p> |
|---|-----------------------------------|------------------|

(15) 附表 5 第 4 段的表現予修訂，在第(7)段中，在第一欄中，廢除 “27 000 kg.” 而代以 —

“27 000 kg:

Provided that this paragraph shall not apply to aeroplanes falling within paragraph (7A).”。

(16) 附表 5 第 4 段的表現予修訂，加入 —

| | | |
|--|-----------------------------------|------------------|
| <p>(7A) Aeroplanes in respect of which there is in force a certificate of airworthiness in the Aerial Work or Private Category and for which an individual certificate of airworthiness was first issued (whether in Hong Kong or elsewhere) on or after 1 January 2005 and which have a maximum total weight authorized exceeding 5 700 kg.</p> | <p>when flying on any flight.</p> | <p>S(viii)”。</p> |
|--|-----------------------------------|------------------|

(17) 附表 5 第 4 段的表現予修訂，廢除第(9)段而代以 —

| | | |
|---|-----------------------------------|------------|
| <p>“(9) Aeroplanes powered by one or more turbine jets or one or more turbine propeller engines which have a maximum total weight authorized exceeding 5 700 kg or which in accordance with the certificate of airworthiness in force in respect of which may carry more than 9 passengers.</p> | <p>when flying on any flight.</p> | <p>X”。</p> |
|---|-----------------------------------|------------|

(18) 附表 5 第 4 段的表現予修訂，在第(12)(a)段中，在第三欄中，廢除 “Y2(iv)” 而代以 “Y(iv)”。

(19) 附表 5 第 4 段的表現予修訂，在第(12)(b)段中，在第三欄中，廢除 “Y2(iv)” 而代以 “Y(iv)” 。

(20) 附表 5 第 4 段的表現予修訂，在第(12)(c)段中，在第三欄中，廢除 “Y2(iv)” 而代以 “Y(iv)” 。

(21) 附表 5 第 4 段的表現予修訂，在第(13)(a)段中，在第三欄中，廢除 “A(i) and (ii) and B(i)” 而代以 “A(i), (ii) and (iii)(a) and B(i)” 。

(22) 附表 5 第 4 段的表現予修訂，在第(13)(a)(i)段中，在第三欄中，廢除 “D” 而代以 “D, F(i) and (vi) and FF” 。

(23) 附表 5 第 4 段的表現予修訂，在第(13)(a)(ii)(aa)段中，在第三欄中，廢除 “E with E(ii) duplicated” 而代以 “E and F” 。

(24) 附表 5 第 4 段的表現予修訂，在第(13)(a)(ii)(bb)段中，在第三欄中，廢除 “E with E(ii) and E(iv) duplicated” 而代以 “E with E(iv) duplicated” 。

(25) 附表 5 第 4 段的表現予修訂，在第(13)(a)(iii)(bb)(aaa)段中，在第三欄中，廢除 “C, E, with E(ii) duplicated, G(iii) and G(v)” 而代以 “C, E, F and G(ii), (iii) and (v)” 。

(26) 附表 5 第 4 段的表現予修訂，在第(13)(a)(iii)(bb)(bbb)段中，在第三欄中，廢除 “C, E, with both E(ii) and E(iv) duplicated, F with F(iv) for all weights, G(iii) and G(v)” 而代以 “C, E with E(iv) duplicated, F and G(ii), (iii) and (v)” 。

(27) 附表 5 第 4 段的表現予修訂，在第(13)(a)段中，加入 —

| | |
|------------------------------|--|
| “(iv) when flying over water | |
| (aa) in the case of a | |
| helicopter or gyroplane | |
| classified in its | |
| certificate of | |
| airworthiness as being | |

- | | |
|---|--------------------|
| <p>of performance group A which is intended to fly a distance from land corresponding to more than 10 minutes at normal cruise speed.</p> | <p>H, K and KK</p> |
| <p>(bb) in the case of a helicopter or gyroplane classified in its certificate of airworthiness as being of performance group B when beyond autorotational or safe forced landing distance from land.</p> | <p>H, K and KK</p> |
| <p>(v) on all flights on which in the event of any emergency occurring during the take-off or during the landing at the intended destination or any likely alternate destination it is reasonably possible that the helicopter or gyroplane would be forced to land onto water.</p> | <p>H</p> |
| <p>(vi) when flying over land areas which have been designated by the State concerned as areas in which search and rescue would be especially difficult where, in the event of an emergency landing, tropical conditions are likely to be met.</p> | <p>U</p> |

| | |
|---|------|
| (vii) when flying over land areas which have been designated by the State concerned as areas in which search and rescue would be especially difficult where, in the event of an emergency landing, polar conditions are likely to be met. | V |
| (viii) when flying at a height of 10 000 ft or more above mean sea level. | L2”。 |

(28) 附表 5 第 4 段的表現予修訂，在第(13)(b)(i)段中 —

(a) 在第三欄中，廢除 “D” ；

(b) 加入 —

| | |
|------------------------------------|---------------------------------|
| “(aa) outside controlled airspace. | D, F(i) and (vi) and FF |
| (bb) within controlled airspace. | E with E(iv) duplicated and F”。 |

(29) 附表 5 第 4 段的表現予修訂，在第(13)(b)(ii)段中，在第三欄中，廢除 “E with both E(ii) and E(iv) duplicated, F(ii), F(iii) and F(v)” 而代以 “E with E(iv) duplicated and F”。

(30) 附表 5 第 4 段的表現予修訂，在第(13)(b)(iii)(bb)段中，在第三欄中，廢除 “C, E with E(ii) duplicated and either E(iv) duplicated” 而代以 “C, E with either E(iv) duplicated”。

(31) 附表 5 第 4 段的表現予修訂，在第(13)(b)(iv)段中，在第三欄中，廢除 “C, E with both E(ii) and E(iv) duplicated” 而代以 “C, E with E(iv) duplicated” 。

(32) 附表 5 第 4 段的表現予修訂，在第(13)(b)(v)(cc)段中，在第二欄中，在 “group A2” 之後加入 “or B” 。

(33) 附表 5 第 4 段的表現予修訂，在第(13)(b)(v)(ee)段中，在第二欄中 —

(a) 廢除 “on a flight” 而代以 “or which actually flies beyond 10 minutes flying time from land on a flight which is either” ；

(b) 廢除 “commander” 而代以 “pilot in command” 。

(34) 附表 5 第 4 段的表現予修訂，在第(13)(b)(x)段中，在第三欄中，廢除 “Y2(i)” 而代以 “Y(i)” 。

(35) 附表 5 第 4 段的表現予修訂，廢除第(14)(c)段。

(36) 附表 5 第 4 段的表現予修訂，在第(14)段中，加入 —

| | | |
|---|----------------------------|--------------------|
| “ (e) which have a certificate of airworthiness issued in the Aerial Work or Private Category and which have a maximum total weight authorized exceeding 7 000 kg: Provided that this paragraph shall not apply to | when flying on any flight. | SS(ii) or (iii)” 。 |
|---|----------------------------|--------------------|

| | | |
|---|--|--|
| helicopters and gyroplanes falling within paragraph (15). | | |
|---|--|--|

(37) 附表 5 第 4 段的表現予修訂，加入 —

| | | |
|--|-----------------------------------|-----------------|
| <p>(15) Helicopters and gyroplanes for which an individual certificate of airworthiness was first issued (whether in Hong Kong or elsewhere) after 1 January 2005 and which have a maximum total weight authorized exceeding 3 175 kg.</p> | <p>when flying on any flight.</p> | <p>SS(iv)”。</p> |
|--|-----------------------------------|-----------------|

(38) 附表 5 第 5 段的等級 A 的第(iii)段現予廢除，代以 —

- “(iii) (a) An accessible first-aid kit.
- (b) (aa) In the case of an aeroplane, accessible and adequate medical supplies as appropriate to the number of passengers the aeroplane is authorized to carry.
- (bb) In the case of a helicopter or gyroplane, one or more first-aid kits as appropriate to the number of passengers the helicopter or gyroplane is authorized to carry.”。

(39) 附表 5 第 5 段的等級 B 的第(i)(b)段現予修訂，廢除 “, in place of the safety belt with one diagonal should strap referred to under sub-paragraph (a)” 。

(40) 附表 5 第 5 段的等級 B 的第(i)(e)段現予修訂，廢除 “cabin attendants” 而代以 “members of the cabin crew” 。

(41) 附表 5 第 5 段的等級 B 的第(ii)段現予修訂，廢除 “commander” 而代以 “pilot in command” 。

(42) 附表 5 第 5 段的等級 D 的第(ii)段現予修訂 —

(a) 在 “altimeter” 之後加入 “, with counter drum-pointer or equivalent presentation,” ；

(b) 廢除 “commander” 而代以 “pilot in command” 。

(43) 附表 5 第 5 段的等級 E 的第(ii)及(iii)段現予廢除，代以 —

“(ii) (a) In the case of an aeroplane, an attitude indicator;

(b) In the case of a helicopter or gyroplane, an attitude indicator for each required pilot and one additional attitude indicator;

(iii) A heading indicator;” 。

(44) 附表 5 第 5 段的等級 E 的第(iv)段現予修訂 —

(a) 在 “altimeter” 之後加入 “, with counter drum-pointer or equivalent presentation,” ；

(b) 廢除 “commander” 而代以 “pilot in command” 。

(45) 附表 5 第 5 段的等級 E 的但書現予修訂 —

(a) 廢除 “gyroscopic bank and pitch indicator” 而代以 “attitude indicator” ；

(b) 在 “(i) of this Scale” 之前加入 “paragraph” 。

(46) 附表 5 第 5 段的等級 F 的第(iv)段現予修訂，廢除 “If the maximum total weight authorized of the aircraft exceeds 5 700 kg a means of indicating” 而代以 “A means of indicating in the flight crew compartment the” 。

(47) 附表 5 第 5 段的等級 F 的第(v)段現予廢除，代以 —

“(v) An airspeed indicating system with a means of preventing malfunction due to either condensation or icing; in the case of an aeroplane with speed limitations expressed in terms of Mach number, a Mach number indicator;” 。

(48) 附表 5 第 5 段的等級 F 現予修訂，加入 —

“(vi) A magnetic compass.” 。

(49) 附表 5 第 5 段現予修訂，加入 —

“*Scale FF*

An airspeed indicator.” 。

(50) 附表 5 第 5 段的等級 G 的第(iii)(b)(bb)(aaa)段現予修訂，廢除 “by readily accessible” 而代以 “be readily accessible” 。

(51) 附表 5 第 5 段的等級 G 的第(iii)(b)(bb)(bbb)段現予修訂，廢除“cabin attendants”而代以“members of the cabin crew”。

(52) 附表 5 第 5 段的等級 G 的第(v)(a)段現予修訂，廢除在“group A,”之後的所有字句而代以“2 landing lights of which at least one is adjustable in flight so as to illuminate the ground in front of and below the helicopter or gyroplane and the ground on either side of the helicopter or gyroplane;”。

(53) 附表 5 第 5 段的等級 G 的第(v)(b)段現予修訂，廢除在“group B,”之後的所有字句而代以“2 landing lights.”。

(54) 附表 5 第 5 段的等級 J 現予修訂 —

(a) 在第(iii)段中，廢除句號而代以分號；

(b) 加入 —

“(iv) Equipment for making the sound signals for preventing collisions at sea.”。

(55) 附表 5 第 5 段的等級 K 的第(i)段的(h)項現予修訂，廢除“sub-paragraph (i)”而代以“item (i)”。

(56) 附表 5 第 5 段的等級 K 的第(i)段的(i)項的但書現予修訂，廢除“sub-paragraph”而代以“item”。

(57) 附表 5 第 5 段現予修訂，加入 —

“*Scale KK*

A permanent or rapidly deployable means of floatation so as to ensure a safe ditching of the helicopter or gyroplane.”。

(58) 附表 5 第 5 段的等級 L1 的第 I 部第(i)段現予修訂，廢除“millibars”而代以“hectopascals”。

(59) 附表 5 第 5 段的等級 L1 的第 II 部的註 A 現予修訂，廢除“millibars”而代以“hectopascals”。

(60) 附表 5 第 5 段的等級 L2 的第 I 部第(ii)(b)段現予修訂，廢除“Cabin attendants”而代以“Members of the cabin crew”。

(61) 附表 5 第 5 段的等級 L2 的第 I 部第(iii)(b)段現予修訂，廢除“Cabin attendants”而代以“Members of the cabin crew”。

(62) 附表 5 第 5 段的等級 L2 的第 II 部第(ii)(b)段現予修訂，廢除“Cabin attendants”而代以“Members of the cabin crew”。

(63) 附表 5 第 5 段的等級 L2 的第 II 部第(ii)(c)段現予修訂，廢除“Cabin attendants”而代以“Members of the cabin crew”。

(64) 附表 5 第 5 段的等級 L2 的第 II 部第(iii)(b)段現予修訂，廢除“Cabin attendants”而代以“Members of the cabin crew”。

(65) 附表 5 第 5 段的等級 L2 的第 II 部的註 A 現予修訂 —

(a) 在“occurs”之後加入逗號；

(b) 廢除“flight level 120 within 5 minutes”而代以“flight level 130 within 4 minutes”。

(66) 附表 5 第 5 段的等級 O 的但書(b)段現予修訂，廢除兩度出現的“commander”而代以“pilot in command”。

(67) 附表 5 第 5 段的等級 P 現予修訂，在“， by reference to a time-scale”之前加入“and retaining the data recorded during at least the last 25 hours of its operation”。

(68) 附表 5 第 5 段的等級 R1 現予廢除。

(69) 附表 5 第 5 段的等級 R2 現予修訂，將該等級重編為等級 R。

(70) 附表 5 第 5 段的等級 R 的第(i)(a)段現予修訂，廢除“cabin attendant”而代以“member of the cabin crew”。

(71) 附表 5 第 5 段的等級 R 的第(ii)(a)段現予修訂，廢除“cabin attendants”而代以“members of the cabin crew”。

(72) 附表 5 第 5 段的等級 S 現予修訂，廢除“A flight”而代以 —

“A flight data recorder required by this Scale shall be capable of retaining the data recorded during at least the last 25 hours of its operation. A cockpit voice recorder required by this Scale shall be capable of retaining the data recorded during at least the last 30 minutes of its operation. For a cockpit voice recorder installed in an aeroplane of a maximum total weight authorized exceeding 5 700 kg for which an individual certificate of airworthiness was first issued after 1 January 2003, it shall be capable of retaining the data recorded during at least the last 2 hours of its operation.

A flight”。

(73) 附表 5 第 5 段的等級 S 的第(i)段現予修訂，廢除“altitude”而代以“attitude”。

(74) 附表 5 第 5 段的等級 S 的第(ii)段現予修訂，在“in respect of the aeroplane”之後加入冒號。

(75) 附表 5 第 5 段的等級 S 的第(iii)段現予修訂，廢除“the level or availability of essential AC electricity supply and”。

(76) 附表 5 第 5 段的等級 S 的第(v)段現予修訂，廢除“altitude”而代以“attitude”。

(77) 附表 5 第 5 段的等級 S 的第(vi)段現予修訂 —

(a) 廢除 “speed, altitude” 而代以 “speed, attitude” ；

(b) 廢除 “position of primary flying control and pitch trim surfaces” 而代以 “position of primary flying controls and pitch trim position” ；

(c) 廢除在 “cockpit warnings relating to” 之後的所有字句而代以 “ground proximity and the master warning system;” 。

(78) 附表 5 第 5 段的等級 S 的第(vii)段現予廢除。

(79) 附表 5 第 5 段的等級 S 現予修訂，加入 —

“(viii) a cockpit voice recorder and a Type IA flight data recorder as described in paragraph 6.3.1.8 in Part I and paragraph 6.10.1.7 in Part II of Annex 6 to the Chicago Convention as amended by all amendments up to and including Amendment 31 to that Part I and all amendments up to and including Amendment 26 to that Part II.” 。

(80) 附表 5 第 5 段的等級 SS 現予修訂，在緊接第(i)段之前加入 —

“For a cockpit voice recorder required by this Scale but installed in helicopters for which an individual certificate of airworthiness was first issued after 1 January 2003, it shall be capable of retaining the data recorded during at least the last 2 hours of its operation.” 。

(81) 附表 5 第 5 段的等級 SS 的第(i)段現予修訂，廢除 “8 hours” 而代以 “10 hours” 。

(82) 附表 5 第 5 段的等級 SS 的第(i)(c)段現予修訂，廢除 “altitude” 而代以 “attitude” 。

(83) 附表 5 第 5 段的等級 SS 的第(ii)段現予修訂，廢除 “8 hours” 而代以 “10 hours” 。

(84) 附表 5 第 5 段的等級 SS 的第(iii)(b)段現予修訂，廢除 “8 hours” 而代以 “10 hours” 。

(85) 附表 5 第 5 段的等級 SS 現予修訂，加入 —

“(iv) A cockpit voice recorder and a Type IVA flight data recorder as described in Attachment B to Part III of Annex 6 to the Chicago Convention as amended by all amendments up to and including Amendment 12 to that Part III with a recording duration of at least 10 hours.” 。

(86) 附表 5 第 5 段的等級 W 的但書現予修訂，廢除 “commander” 而代以 “pilot in command” 。

(87) 附表 5 第 5 段的等級 X 現予廢除，代以 —

“*Scale X*

A ground proximity warning system which has a forward looking terrain avoidance function:

Provided that if the equipment becomes unserviceable, the aircraft may fly or continue to fly until it first lands at a place at which it is reasonably practicable for the equipment to be repaired or replaced.” 。

(88) 附表 5 第 5 段的等級 Y1 現予廢除。

(89) 附表 5 第 5 段的等級 Y2 現予修訂，將該等級重編為等級 Y。

(90) 附表 5 第 5 段的等級 Y 的第(iv)(b)段現予修訂，廢除 “the cabin attendants” 而代以 “members of the cabin crew”。

(91) 附表 5 第 5 段現予修訂，加入 —

“Scale ZZ

(i) A serviceable autopilot that has at least altitude hold and heading select modes;

(ii) A headset with a boom microphone or equivalent; and

(iii) Means of displaying charts that enables them to be readable in all ambient light conditions.”。

75. Radio and Radio Navigation Equipment to be carried in Aircraft

(1) 附表 6 現予修訂，廢除在開首處的 “Article 14” 而代以 “Articles 14 and 37A”。

(2) 附表 6 第 2 段的表現予修訂，在第二欄中，廢除 “A B C D E F G H” 而代以 “A B C D E F G H J”。

(3) 附表 6 第 2 段的表現予修訂，在第(1)(a)段中，在第二欄中，廢除 “A” 而代以 “A*”。

(4) 附表 6 第 2 段的表現予修訂，在第(1)段中 —

(a) 在(c)節中，廢除句號；

(b) 加入 —

“(d) when flying for the purpose
of public transport E*”。

(5) 附表 6 第 2 段的表現予修訂，在第(3)段中，加入 —

“(e) when flying for the purpose
of public transport E”。

(6) 附表 6 第 2 段的表現予修訂，加入 —

“(4) All -

(a) turbine-engined
aeroplanes registered
in Hong Kong, wherever
they may be; and

(b) turbine-engined
aeroplanes wherever
registered when flying
in Hong Kong,

when flying for the purpose
of public transport, which
have a maximum total weight
authorized exceeding 5 700
kg or which in accordance
with the certificate of
airworthiness in force in
respect of the aeroplanes
may carry more than 19
passengers.

J

(5) All –

(a) turbine-engined
aeroplanes registered
in Hong Kong, wherever
they may be; and

(b) turbine-engined
aeroplanes wherever
registered when flying
in Hong Kong,

when flying for a purpose
other than public transport,
which have a maximum total
weight authorized exceeding
15 000 kg or which in
accordance with the
certificate of airworthiness
in force in respect of the
aeroplanes may carry more
than 30 passengers.

J”。

(7) 附表 6 第 3 段現予修訂，在等級 E 中，在 “equipment” 之
後加入 —

“which includes a pressure altitude reporting
transponder capable of operating in Mode A and Mode
C and is capable of being operated in accordance
with such instructions as may be given to the
aircraft by the air traffic control unit”。

(8) 附表 6 第 3 段現予修訂，加入 —

“Scale J

An airborne collision avoidance system.”。

(9) 附表 6 第 4 段現予修訂 —

- (a) 在第(3)節中，廢除末處的“and”；
- (b) 在第(4)節中，廢除句號而代以分號；
- (c) 加入 —

“(5) “airborne collision avoidance system” means an aeroplane system which —

- (a) is designed to provide advice and appropriate avoidance manoeuvres to the pilot in relation to other aeroplanes which are equipped with secondary surveillance radar transponders and are in undue proximity;
- (b) is based on secondary surveillance radar transponder signals;
- (c) operates independently of ground based equipment; and
- (d) conforms to requirements specified for the purpose;

(6) “Mode A” means replying to an interrogation from secondary surveillance radar units on the surface to elicit transponder replies for identity and surveillance with identity provided in the form of a 4 digit identity code; and

(7) “Mode C” means replying to an interrogation from secondary surveillance radar units on the surface to elicit transponder replies for automatic pressure-altitude transmission and surveillance.”。

76. Areas specified in connection with the carriage of Flight Navigators as members of the Flight Crews or Approved Navigational Equipment on Public Transport Aircraft

(1) 附表 8 的標題現予修訂，廢除 “FLIGHT NAVIGATORS AS MEMBERS OF THE FLIGHT CREWS OR”。

(2) 附表 8 現予修訂，廢除在開首處的 “Article 18(4)” 而代以 “Articles 18(4) and 98(7) and Schedule 5”。

77. Flight Crew of Aircraft, Licences and Ratings

(1) 附表 9 的 A 部第 1 段現予修訂，在 “**Private Pilot’s Licence (Aeroplanes)**” 的標題下，在但書中 —

- (a) 在(c)(i)節中，廢除在 “airspace” 之後的所有字句而代以 “when the flight visibility is less than 3 kilometres;” ；
- (b) 在(c)(ii)節中，廢除 “5 nautical miles” 而代以 “10 kilometres” ；
- (c) 在(c)(iii)節中，廢除末處的 “and” ；
- (d) 在(d)(ii)節中，廢除句號而代以 “; and” ；
- (e) 加入 —

“(e) he shall not, unless his licence includes an instrument rating (aeroplanes), fly as pilot in command or co-pilot of such an aeroplane flying in controlled airspace notified for the purposes of this Schedule in circumstances which require compliance with the Instrument Flight Rules.”。

(2) 附表 9 的 A 部第 1 段現予修訂，在 “**Commercial Pilot’s Licence (Aeroplanes)**” 的標題下 —

(a) 在第(1)(a)段中，廢除 “1 nautical miles” 而代以 “3 kilometres” ；

(b) 在第(1)(b)段中，廢除 “1 nautical mile” 而代以 “1 800 metres” ；

(c) 廢除第(2)段的但書(e)段；

(d) 在第(2)段的但書中，加入 —

“(f) he shall not, unless his licence includes an instrument rating (aeroplanes), fly as pilot in command or co-pilot of such an aeroplane flying in controlled airspace notified for the purpose of this Schedule in circumstances which require compliance with the Instrument Flight Rules.” ；

(e) 在第(3)段中，廢除在 “for any purpose whatsoever” 之後的所有字句而代以句號；

(f) 廢除第(4)段；

(g) 加入 —

“(5) Subject to paragraph (6), he shall be entitled to fly as pilot in command of an aeroplane of a type specified in any flying instructor’s rating or assistant flying instructor’s rating included in the licence on a flight for the purpose of aerial work which consists of –

- (a) the giving of instruction in flying; or
- (b) the conducting of flying tests for the purposes of this Order,

in either case in an aeroplane owned, or operated under arrangements entered into, by a flying club of which the person giving the instruction or conducting the test and the person receiving the instruction or undergoing the test are both members.

(6) He shall not be entitled to exercise the privileges contained in paragraph (5) other than in an aeroplane which he is entitled to fly as pilot in command on a private flight, an aerial work flight or a public transport flight pursuant to the privileges set out in paragraph (1) or (2) of these privileges.

(7) He shall not at any time after he attains the age of 60 years fly as pilot in command or co-pilot of any aeroplane on any flight for the purpose of public transport unless the aeroplane is fitted with dual controls and carries a second pilot who has not attained the age of 60 years and who holds

an appropriate licence under this Order entitling him to act as pilot in command or co-pilot of that aeroplane.

(8) He shall not at any time after he attains the age of 65 years act as pilot in command or co-pilot of any aeroplane on a flight for the purpose of public transport.”

(3) 附表 9 的 A 部第 1 段現予修訂，在緊接 “**Airline Transport Pilot’s Licence (Aeroplanes)**” 的標題之前加入 —

“Multi-Crew Pilot’s Licence (Aeroplanes)

Minimum Age – 18 years

Maximum Period of Validity – 10 years

Privileges:

(1) The holder of the licence shall be entitled to fly as co-pilot of any aeroplane of a type specified in the aircraft rating included in the licence when the aeroplane is required to be operated with more than one pilot and is engaged on a flight for any purpose whatsoever:

Provided that –

- (a) he shall not, unless his licence includes an instrument rating (aeroplanes), fly such an aeroplane on any scheduled journey;

- (b) he shall not fly such an aeroplane on any flight for the purpose of public transport after he attains the age of 60 years unless the aeroplane is fitted with dual controls and carries a second pilot who has not attained the age of 60 years and who holds an appropriate licence under this Order entitling him to act as pilot in command of that aeroplane;
- (c) he shall not at any time after he attains the age of 65 years fly such an aeroplane on any flight for the purposes of public transport.

(2) He shall be entitled to exercise the privileges of a Private Pilot's Licence (Aeroplanes) in an aeroplane of any of the groups or types specified in his licence provided that the requirements for the issue of a Private Pilot's Licence (Aeroplanes) are met and that his licence carries an appropriate endorsement which enables him to do so.

(3) He shall be entitled to exercise the privileges of his instrument rating (aeroplanes) in a single pilot operation provided that he has demonstrated to the Chief Executive the ability to act as pilot in command in a single pilot operation exercised solely by reference to instruments and that his licence carries an appropriate endorsement which enables him to do so." °

(4) 附表 9 的 A 部第 1 段現予修訂，在 “**Airline Transport Pilot’s Licence (Aeroplanes)**” 的標題下，廢除在 “shall not apply” 之後的所有字句而代以句號。

(5) 附表 9 的 A 部第 2 段現予修訂，在 “**Private Pilot’s Licence (Helicopters and Gyroplanes)**” 的標題下，在但書 (e) 段中，廢除在 “flying in” 之後的所有字句而代以 “controlled airspace notified for the purposes of this Schedule in circumstances which require compliance with the Instrument Flight Rules.”。

(6) 附表 9 的 A 部第 2 段現予修訂，在 “**Commercial Pilot’s Licence (Helicopters and Gyroplanes)**” 的標題下 —

- (a) 廢除第 (2) 段的但書 (e) 段；
- (b) 在第 (2) 段的但書 (f) 段中，廢除在 “flying in” 之後的所有字句而代以 “controlled airspace notified for the purposes of this Schedule in circumstances which require compliance with the Instrument Flight Rules.”；
- (c) 在第 (3) 段中，廢除在 “for any purpose whatsoever” 之後的所有字句而代以句號；
- (d) 加入 —

“(3A) He shall not at any time after he attains the age of 60 years fly as pilot in command or co-pilot of any helicopter or gyroplane on any flight for the purposes of public transport unless the helicopter or gyroplane is fitted with dual controls and carries a second pilot who has not attained the age of 60 years and who holds an appropriate licence under this Order entitling him to act as pilot in command or co-pilot of that helicopter or gyroplane.”。

(7) 附表 9 的 A 部第 2 段現予修訂，在 “**Airline Transport Pilot’s Licence (Helicopters and Gyroplanes)**” 的標題下，廢除在 “shall not apply” 之後的所有字句而代以句號。

(8) 附表 9 的 A 部第 3 段現予修訂，在 “**Commercial Pilot’s Licence (Balloons)**” 的標題下，廢除 “6 months*” 而代以 “10 years*”。

(9) 附表 9 的 A 部第 3 段現予修訂，在 “**Commercial Pilot’s Licence (Airships)**” 的標題下，廢除 “17 years” 而代以 “18 years”。

(10) 附表 9 的 A 部第 5 段現予修訂，廢除 —

“Flight Navigator’s Licence

Minimum Age – 21 years

Maximum Period of Validity – 10 years

Privileges: The holder of the licence shall be entitled to act as flight navigator in any aircraft.”。

(11) 附表 9 的 A 部第 5 段現予修訂，廢除 —

“Flight Radiotelephony Operator’s General Licence

Minimum Age – 18 years

Maximum Period of Validity – 10 years

Privileges: The holder of the licence shall be entitled to operate radiotelephony apparatus in any aircraft.”。

- (12) 附表 9 的 A 部第 5 段現予修訂，廢除 —

“Flight Radiotelephony Operator’s Licence

Minimum Age – 20 years

Maximum Period of Validity – 12 months

Privileges: The holder of the licence shall be entitled to operate radiotelegraphy and radiotelephony apparatus in any aircraft.”。

- (13) 附表 9 的 A 部第 5 段現予修訂，廢除 —

“Flight Radiotelegraphy Operator’s Temporary Licence

Minimum Age – 18 years

Maximum Period of Validity – 12 months

Privileges: The holder of the licence shall be entitled to operate radiotelegraphy and radiotelephony apparatus in any aircraft under the supervision of a person who is the holder of a flight radiotelegraphy operator’s licence.”。

- (14) 附表 9 的 B 部第 1 段現予修訂，廢除兩度出現的 “airspace” 而代以 “controlled airspace”。

- (15) 附表 9 的 C 部第 1(a)段的表現予修訂 —

(a) 在個案 B 中，在第二欄中，在未處加入 —

“Multi-Crew Pilot’s Licence (Aeroplanes)” ；

- (b) 在個案 C 中，在第二欄中，在末處加入 —
“Multi-Crew Pilot’s Licence (Aeroplanes)” ；
- (c) 在個案 D 中，在第二欄中，在末處加入 —
“Multi-Crew Pilot’s Licence (Aeroplanes)” ；
- (d) 在個案 E 中，在第二欄中，在末處加入 —
“Multi-Crew Pilot’s Licence (Aeroplanes)” ；
- (e) 廢除個案 F 。

(16) 附表 9 的 C 部第 4(b)段現予修訂，在 “(aeroplanes)” 之後加入 “, an instrument rating (helicopters)” 。

(17) 附表 9 的 C 部第 5(c)段現予廢除。

(18) 附表 9 的 C 部第 6 段現予修訂，廢除 “, F” 。

78. Air Traffic Controllers: Ratings

(1) 附表 10 現予修訂，廢除在開首處的 “Article 66(2)” 而代以 “Articles 65 and 66” 。

(2) 附表 10 第 1 段的但書 (a)段現予修訂，廢除 “approach control rating” 而代以 “approach control procedural rating” 。

(3) 附表 10 第 1 段的但書 (b)及 (c)段現予廢除，代以 —

“(b) The approach control procedural rating and the approach control surveillance rating;

(c) The area control procedural rating and the area control surveillance rating;

- (d) The approach control procedural rating and the approach control surveillance rating and the area control surveillance rating in accordance with the procedures as stated in the relevant air traffic control instructions and the Manual of Air Traffic Control for aircraft operating within the Hong Kong Control Zone or the Terminal Control Area, as notified.”。
- (4) 附表 10 第 2(1)段現予修訂 —
- (a) 廢除 “radar equipment” 而代以 “air traffic service surveillance system” ；
- (b) 廢除 “radar control rating” 而代以 “surveillance control rating” 。
- (5) 附表 10 第 2(2)段現予修訂 —
- (a) 廢除 “Approach Control Rating” 而代以 “Approach Control Procedural Rating” ；
- (b) 廢除 “radar equipment” 而代以 “air traffic service surveillance system” ；
- (c) 廢除 “radar control rating” 而代以 “surveillance control rating” ；
- (d) 廢除 “in the vicinity of the aerodrome traffic zone” 而代以 “within the Hong Kong Control Zone or the Terminal Control Area, as notified” 。
- (6) 附表 10 第 2(3)段現予修訂 —
- (a) 廢除 “Approach Radar Control Rating” 而代以 “Approach Control Surveillance Rating” ；

(b) 廢除 “surveillance radar equipment” 而代以
“air traffic service surveillance system” ；

(c) 廢除 “40 nautical miles of the aerodrome
traffic zone” 而代以 “the Hong Kong Control
Zone or the Terminal Control Area, as
notified” 。

(7) 附表 10 第 2(5)及(6)段現予廢除，代以 —

“(5) Area Control Procedural Rating shall entitle the holder of the licence to provide air traffic control service without the aid of any air traffic service surveillance system to aircraft flying in the control areas within the Hong Kong Flight Information Region, as notified in the Aeronautical Information Publication (AIP) for which the rating is valid.

(6) Area Control Surveillance Rating shall entitle the holder of the licence to provide air traffic control service with the aid of any type of air traffic service surveillance system for which the rating is valid to aircraft flying in the control areas within the Hong Kong Flight Information Region, as notified in the Aeronautical Information Publication (AIP) for which the rating is valid.” 。

(8) 附表 10 第 2(7)段現予廢除。

(9) 附表 10 現予修訂，加入 —

“3. In this Schedule —

- “(xvii) such terms of any permission granted to the operator of the aircraft under Article 14A of this Order as may be necessary to enable the pilot in command of the aircraft to determine whether he can comply with Article 32(b)(ii) of this Order;
- (xviii) procedures for the operation of any airborne collision avoidance system carried on the aircraft;
- (xix) the establishment and maintenance of an accident prevention and flight safety programme:” °

(4) 附表 11 的 B 部第 1(2)(c)(ii)段現予修訂，廢除 “flight.” 而代以 “flight, or in a simulator of the type approved for the purpose by the Chief Executive subject to such conditions as are required by the Chief Executive.” °

(5) 附表 11 的 B 部第 1(2)段現予修訂，加入 —

“(d) In the case of a helicopter, every pilot included in the flight crew whose licence does not include an instrument rating but who is intended to fly at night under visual flight conditions shall within the relevant period have been tested, by or on behalf of the operator, in a helicopter of the type to be used on the flight —

- (i) as to his competence to act as pilot of such a helicopter, while executing normal manoeuvres and procedures; and

(ii) as to his proficiency to act as pilot of such a helicopter, while executing specified manoeuvres and procedures in flight in instrument flight conditions by means approved by the Chief Executive.”。

(6) 附表 11 的 B 部第 1(4)段現予廢除。

(7) 附表 11 的 B 部第 1(6)段現予修訂，在 “relevant period” 的定義中 —

(a) 在 (b)段中，在 “(2)(c)(i)” 之後加入 “, (2)(d)(ii)” ；

(b) 在 (c)段中，廢除 “(3)(a), (4)” 而代以 “(2)(d)(i), (3)(a)” ；

(c) 在但書第 (i)段中，廢除 “or (2)(c)(i)” 而代以 “, (2)(c)(i) or (2)(d)(ii)” ；

(d) 在但書第 (ii)段中，廢除句號而代以分號。

(8) 附表 11 的 B 部第 1(6)段現予修訂，加入 —

““visual flight conditions” means weather conditions such that the pilot is able to fly by visual reference to objects outside the aircraft.”。

80. Documents to be Carried by Aircraft Registered in Hong Kong

(1) 附表 12 現予修訂，廢除自 “On a flight for the purpose of public transport:” 起至 “A, B, C and G.” 為止的所有字句而代以 —

“On a flight for the purpose of public transport:

Documents A, B, C, D, E, F, H and, if the flight is external air navigation, Documents G, I and K.

On a flight for the purpose of aerial work:

Documents A, B, C, E, F and, if the flight is external air navigation, Documents G, I and K.

On a private flight, being external air navigation:

Documents A, B, C, G and I.

On a flight made in accordance with the terms of a permission granted to the operator of the aircraft under Article 14A of this Order:

Document J.” ◦

(2) 附表 12 現予修訂，廢除 “H” 的定義而代以 —

““H” means those parts of the operations manual, if any, required by Article 25(2)(a)(iii) of this Order to be carried on the flight;” ◦

(3) 附表 12 現予修訂，加入 —

““I” means a copy of the notified procedures to be followed by the pilot in command of an intercepted aircraft, and the notified visual signals for use by intercepting and intercepted aircraft;

“J” means the permission, if any, granted in respect of the relevant aircraft under Article 14A of this Order;

“K” means a certified true copy of the air operator’s certificate (or its equivalent document) in force in respect of the operator together with a copy of the authorizations, conditions and limitations relevant to the type of the aircraft and issued in conjunction with the air operator’s certificate (or its equivalent document).”。

81. 修訂附表 13

(1) 附表 13 的 A 部現予修訂 —

(a) 廢除 —

“19 Requirement for appropriate licence”

而代以 —

“19 Flight crew – requirement of licences” ;

(b) 廢除 —

“32 Pre-flight action by commander of aircraft”

而代以 —

“32 Pre-flight action by pilot in command of aircraft” ;

(c) 廢除 —

“34 Duties of commander on flight for public transport of passengers”

而代以 —

“34 Duties of pilot in command on flight for public transport of passengers” ;

(d) 廢除 —

“51 Requirement to obey lawful commands of aircraft commander”

而代以 —

“51 Requirement to obey lawful commands of pilot in command of aircraft” ;

(e) 廢除 —

“66 (except (4)) Requirement for licensing of air traffic controllers and aerodrome flight information service officers”

而代以 —

“66 Requirement for licensing of air traffic controllers” ;

(f) 廢除 —

“67 Requirement for aerodrome information service manual”

而代以 —

“67 Manual of Air Traffic Control” 。

(2) 附表 13 的 A 部現予修訂，加入 —

“12(7) and (8) Exercise of privilege of aircraft maintenance licence whilst unfit

14A Minimum equipment requirements

36A Requirement for area navigation and required navigation performance capabilities - aircraft registered in Hong Kong

36B Requirement for area navigation and required navigation performance capabilities - aircraft registered outside Hong Kong

36C Requirement for
maintaining height
keeping performance
capabilities -
aircraft registered in
Hong Kong

36D Requirement for
maintaining height
keeping performance
capabilities -
aircraft registered
outside Hong Kong

37A Requirement for use of
airborne collision
avoidance system”。

(3) 附表 13 的 B 部現予修訂 —

(a) 廢除 —

“49 Prohibition of drunkenness
in aircraft”

而代以 —

“49 Passengers and crew members
not to be under influence
of psychoactive
substances” ；

(b) 廢除 —

“85 Operator’s or commanders’
obligations in respect of
flights over any place
outside Hong Kong”

而代以 —

“85 Operator’s or pilot in command’s obligations in respect of flights over any place outside Hong Kong” 。

82. Rules of the Air

(1) 附表 14 現予修訂，廢除在開首處的 “Article 64” 而代以 “Articles 64 and 98(1)” 。

(2) 附表 14 第 1 條現予修訂，加入 —

““Day” means the time from half an hour before sunrise until half an hour after sunset (both times exclusive), sunrise and sunset being determined at surface level.” 。

(3) 附表 14 第 5(3)條現予修訂，廢除 “saving life.” 而代以 “fire fighting or prevention, life-saving or law enforcement operations and including the training of personnel engaged in such activities.” 。

(4) 附表 14 第 5 條現予修訂 —

(a) 廢除 —

“*Simulated instrument flight*”

而代以 —

“6. **Simulated instrument flight**” ；

(b) 廢除 —

“(6) An aircraft shall not”

而代以 —

“(1) An aircraft shall not” ；

(c) 廢除 —

“For the purposes of this Rule”

而代以 —

“(2) For the purposes of this Rule,” ；

(d) 廢除 —

“*Practice Instrument Approaches*”

而代以 —

“7. **Practice instrument approaches**” ；

(e) 廢除 —

“(7) Within Hong Kong”

而代以 —

“Within Hong Kong” 。

(5) 附表 14 第 11(2)(a)(i)條現予修訂，廢除 “100 degrees” 而代以 “110 degrees” 。

(6) 附表 14 第 11(2)(a)(ii)條現予修訂，廢除 “100 degrees” 而代以 “110 degrees” 。

(7) 附表 14 第 20(2)條現予修訂，廢除 “aerodrome flight information service unit” 而代以 “flight information service unit” 。

(8) 附表 14 第 20(3)條現予修訂，廢除自 “more than” 起至 “5 700 kg” 為止的所有字句而代以 “outside Hong Kong, the pilot in command of an aircraft” 。

(9) 附表 14 第 22A 條現予廢除。

(10) 附表 14 第 23 條現予修訂 —

(a) 將該條重編為第 23(1)條；

(b) 在第(1)款中，廢除在 “surface.” 之後的所有字句；

(c) 加入 —

“(2) For the purposes of this Rule,
“Special VFR flight” means a flight —

(a) made in a control zone in any notified airspace in meteorological condition below Visual Meteorological Conditions or at night;

(b) in respect of which the appropriate air traffic control unit has given permission for the flight to be made in accordance with special instructions given by that unit instead of in accordance with the Instrument Flight Rules; and

(c) in the course of which the aircraft complies with any instructions given by that unit and remains clear of cloud and in sight of the surface.”。

(11) 附表 14 第 26 條表 I 的標題現予修訂，廢除 “24 500 feet” 而代以 “9 000 feet”。

(12) 附表 14 第 26 條表 II 現予廢除，代以 —

“TABLE II – Flights at or above Flight Level (FL) 110

| Magnetic Track | Cruising Level |
|--|--|
| Less than 180 degrees | FL 110 |
| | FL 130 |
| | FL 150 |
| | FL 170 |
| | FL 190 |
| | FL 210 |
| | FL 230 |
| | FL 250 |
| | FL 270 |
| | FL 290 |
| | FL 310 |
| | FL 330 |
| | FL 350 |
| | FL 370 |
| | FL 390 |
| | FL 410 or higher levels at intervals of 4 000 feet |
| 180 degrees but less than 360 degrees | FL 120 |
| | FL 140 |
| | FL 160 |
| | FL 180 |

FL 200
FL 220
FL 240
FL 260
FL 280
FL 300
FL 320
FL 340
FL 360
FL 380
FL 400
FL 430 or higher levels
at intervals of 4 000
feet”。

(13) 附表 14 第 34 條的標題現予修訂，廢除 “**two**” 而代以 “**tow**”。

(14) 附表 14 第 34(2)(*b*)條現予修訂，廢除 “appropriate” 而代以 “appropriate”。

(15) 附表 14 第 35(1)條的表現予修訂，廢除兩度出現的 “aerodrome flight information unit” 而代以 “flight information service unit”。

(16) 附表 14 第 35(2)條現予修訂 —

(*a*) 廢除 “commander” 而代以 “pilot in command”；

(*b*) 廢除兩度出現的 “aerodrome flight information unit” 而代以 “flight information service unit”。

(17) 附表 14 第 35(3)(b)條現予修訂，廢除 “aerodrome flight information unit” 而代以 “flight information service unit”。

(18) 附表 14 第 VIII 條現予廢除。

83. Air Navigation (General) Regulations

(1) 附表 15 現予修訂，廢除在開首處的 “Article 9(3)(a)(iii), 11(3) and (6)(a)(iii), 14, 27(1)(c), 28(4), 29(1), 36, 78 and 86(1)” 而代以 “Articles 11(3), 14(1)(b), 27(1)(c), 28(4), 29(1), 36, 36C(1), 78, 86(1) and 97”。

(2) 附表 15 第 1(2)(b)條現予廢除，代以 —

“(b) Where any immersion suit is worn or carried by a passenger or crew member, 3 kg shall be added to the appropriate weight shown in Table 1 in each case.”。

(3) 附表 15 第 1(3)(a)條現予修訂，廢除 “the total weight of the aircraft the respective total weights of the baggage and cargo” 而代以 “the total weight of a passenger aircraft, the respective total weights of the hold baggage and cargo”。

(4) 附表 15 第 1 條表 2 的第 1 欄現予修訂，廢除 “3 kg” 而代以 “5 kg”。

(5) 附表 15 第 1(3)條現予修訂，廢除 —

“(a) If Table 2”

而代以 —

“(b) If Table 2”。

(6) 附表 15 第 1 條現予修訂，加入 —

“(3A) For the purpose of calculating the total weight of a freight aircraft, the respective total weights of the baggage and cargo entered in the load sheet shall be computed from the actual weight of each piece of baggage, cargo or cargo container and for that purpose each piece or container shall be separately weighed;

Provided that -

- (a) any horses carried as cargo may, subject to paragraph (4) of this Regulation, be calculated at not less than the weights shown in Table 3 and the load sheet shall bear a notation to that effect -

Table 3

For the purposes of this Table, a hand equals 4 inches.

| | |
|--|--------|
| Foal | 200 kg |
| Yearlings | 400 kg |
| Mares & Stallions (2 years old or over) .. | 500 kg |
| Ponies (not more than 15 hands high) | 400 kg |
| Ponies (more than 15 hands high) | 500 kg |

- (b) the total weights of any baggage carried may, subject to paragraph (4) of this Regulation, be calculated at not less than the weights shown in Table 4 and the load sheet shall bear a notation to that effect –

Table 4

| | |
|-------------------------------|---------|
| Baggage per crew member | 16 kg |
| Baggage per passenger | 16 kg”。 |

(7) 附表 15 第 4 條的標題現予修訂，在 “**Performance Group A**” 之後加入 “**or Performance Group B**”。

(8) 附表 15 第 4 條現予修訂，在 “performance group A” 之後加入 “or performance group B”。

(9) 附表 15 第 4(1)條現予修訂，廢除 “for altitude and temperature”。

(10) 附表 15 第 4(3)(a)條現予修訂，在 “more than 15°” 之後加入 “before reaching 1 500 feet”。

(11) 附表 15 第 4(7)(b)(v)(bb)條現予修訂，在 “of landing” 之後加入 “or not less than 150 per cent of the forecast wind component in the direction of landing”。

(12) 附表 15 第 5(3)(a)條現予修訂，廢除 “reading 1 500 feet” 而代以 “reaching 1 500 feet”。

(13) 附表 15 第 5(4)(a)條現予修訂，在 “more than 15°” 之後加入 “before reaching 1 500 feet”。

(14) 附表 15 第 5(8)條現予修訂，廢除 “with all power units operating and with one power unit inoperative” 而代以 “with all power units operating or with one power unit inoperative” 。

(15) 附表 15 第 6(2)(e)條現予廢除，代以 —

“(e) not more than 50 per cent of the reported wind component opposite to the direction of take-off or not less than 150 per cent of the reported wind component in the direction of take-off,

do not exceed the take-off run available and the emergency distance available respectively, at the aerodrome at which the take-off is to be made.” 。

(16) 附表 15 第 7(1)(c)條現予修訂 —

(a) 在 “The aeroplane” 之後加入 “, at any time after it reaches a height of 1 000 feet above the aerodrome from which take-off is to be made,” ；

(b) 廢除 “meterological” 而代以 “meteorological” ；

(c) 在 “operations manual” 之後加入 “relating to the aeroplane” 。

(17) 附表 15 第 7(1)條現予修訂，加入 —

“(e) The landing distance required does not, at the aerodrome at which it is intended to land and at any alternate aerodrome, exceed 70 per cent of the landing distance available on the most suitable runway for a landing in still air conditions, and for the purposes of this paragraph the distance required to land from a

height of 50 feet shall be taken to be that specified as being appropriate to –

- (i) the landing weight;
- (ii) the altitude at the aerodrome; and
- (iii) the temperature in the specified international standard atmosphere appropriate to the altitude at the aerodrome.”。

(18) 附表 15 第 8(2)(i)(a)條現予修訂，在“operations manual”之後加入“relating to the aeroplane”。

(19) 附表 15 第 14(2)(a)條現予修訂，廢除“aerodrome flight information service”而代以“flight information service unit”。

(20) 附表 15 第 14(2)(c)條現予修訂 —

(a) 在第(iv)節中，廢除“radar equipment.”而代以“air traffic service surveillance system;”；

(b) 加入 —

“(v) global positioning system.”。

(21) 附表 15 第 14(3)條現予修訂，在“are included in the operations manual”之後加入“relating to the aeroplane”。

(22) 附表 15 第 15(1)及(2)條現予廢除，代以 —

“(a) replacement of landing gear tyres, landing skids or skid shoes;

- (b) replacement of elastic shock absorber cord units on landing gear where special tools are not required;
- (c) replacement of defective safety wiring or split pins excluding those in engine, transmission, flight control and rotor systems;
- (d) patch-repairs to fabric not requiring rib stitching or the removal of structural parts or control surfaces, if the repairs do not cover up structural damage and do not include repairs to rotor blades;
- (e) repairs to upholstery and decorative furnishing of the cabin or cockpit interior when repair does not require dismantling of any structure or operating system or interfere with an operating system or affect the structure of the aircraft;
- (f) repairs, not requiring welding, to fairings, non-structural cover plates and cowlings;
- (g) replacement of side windows where that work does not interfere with the structure or with any operating system;
- (h) replacement of safety belts or safety harnesses;
- (i) replacement of seats or seat parts not involving dismantling of any structure or of any operating system;
- (j) replacement of bulbs, reflectors, glasses, lenses or lights;

- (k) replacement of any cowling not requiring removal of the propeller, rotors or disconnection of engine or flight controls;
- (l) replacement of unserviceable sparking plugs;
- (m) replacement of batteries;
- (n) replacement of wings and tail surfaces and controls, the attachments of which are designed to provide for assembly immediately before each flight and dismantling after each flight;
- (o) replacement of main rotor blades that are designed for removal where special tools are not required;
- (p) replacement of generator and fan belts designed for removal where special tools are not required;
- (q) replacement of VHF communication equipment, being equipment which is not combined with navigation equipment.”。

(23) 附表 15 第 16(4)(g)條現予修訂，廢除“equipment”而代以“equipment”。

(24) 附表 15 第 17 條的標題現予修訂，在“**Navigation Performance**”之後加入“**and Height Keeping Performance**”。

(25) 附表 15 第 17 條現予修訂，加入 —

“(1A) For the purposes of this Regulation, “flight time” means the total time from the moment an aircraft first moves under its own power for the purpose of taking off until the moment it comes to rest at the end of the flight.

(1B) With reference to Article 36C of this Order the following height keeping performance capability is prescribed, that is to say, a capability to ensure that –

- (a) altimetry system error shall be in compliance with paragraph 2.1.1(2) of the Regional Supplementary Procedures (Document 7030/4)-NAT Part 1 Rules of the Air, Air Traffic Services and Search and Rescue (ICAO Regional Procedures, Fourth Edition-1987);
- (b) in respect of aircraft first registered in a Contracting State on or after 1 January 1997, altitude can be automatically controlled within a tolerance band of +/- 65 feet; and
- (c) in respect of aircraft first registered in a Contracting State before 1 January 1997, altitude can be automatically controlled within a tolerance band of +/- 130 feet.” ◦

(26) 附表 15 第 17(2)條現予修訂 —

- (a) 廢除 “flight level 275 to flight level 400” 而代以 “flight level 285 to flight level 420” ；
- (b) 廢除 “65°00′ N 76°45′ W” 而代以 “65°00′ N 57°45′ W” ；
- (c) 廢除 “27°00′ N 25°00′ W” 而代以 —
- “27°00′ N 40°00′ W
- 22°18′ N 40°00′ W
- 17°00′ N 37°30′ W
- 24°00′ N 25°00′ W” 。

84. The Air Navigation (Dangerous Goods) Regulations

(1) 附表 16 第 10 條現予修訂，廢除在 “pollution control.” 之後的所有字句。

(2) 比較表現予廢除。

行政會議秘書

行政會議廳

2008 年 月 日

註釋

本命令修訂《1995年飛航(香港)令》(第448章, 附屬法例C) (“《1995年令》”)。

2. 本命令的主要目的是 —

(a) 實施有關適航、飛機設備、安全管理、數據保存及人員牌照的 —

(i) 最新的獲國際民用航空組織(“民航組織”)採用的主要國際標準及建議措施；及

(ii) 適用的國際慣例；及

(b) 訂定所需條文, 以處理根據《國際民用航空公約》(“《芝加哥公約》”)第83 bis條作出的職能及責任轉移而出現的情況。

3. 民航組織採用的該等國際標準及建議措施均載於《芝加哥公約》的附件內。

4. 本命令亦將若干已過時的提述及條文刪除, 及更正在《1995年令》中若干文本上的錯誤。

| | | | | |
|----------|------|--|-------------------|-----------------|
| Chapter: | 448C | AIR NAVIGATION (HONG KONG) ORDER 1995 | Gazette Number | Version Date |
|----------|------|--|-------------------|-----------------|

| | | | | |
|----------|---|---------------------------|------------|------------|
| Section: | 3 | Aircraft to be registered | 36 of 1999 | 01/07/1997 |
|----------|---|---------------------------|------------|------------|

Remarks:

Adaptation amendments retroactively made - see 36 of 1999 s. 3

PART I

REGISTRATION AND MARKING OF AIRCRAFT

- (1) An aircraft shall not fly in or over Hong Kong unless it is registered in:
- (a) (Repealed 36 of 1999 s. 3)
 - (b) a Contracting State; or
 - (c) some other country in relation to which there is in force an agreement between the Central People's Government or the Government of the Hong Kong Special Administrative Region and the Government of that country which makes provision for the flight over Hong Kong of aircraft registered in that country; (36 of 1999 s. 3)

Provided that:

- (i) any aircraft may fly unregistered on any flight which:
 - (a) begins and ends in Hong Kong without passing over any other country; and
 - (b) is in accordance with the "B Conditions" set forth in Schedule 2 to this Order.
- (ii) this paragraph shall not apply to any kite or captive balloon.

(2) If an aircraft flies over Hong Kong in contravention of paragraph (1) of this Article in such manner or circumstances that if the aircraft had been registered in Hong Kong an offence against this Order or any regulations made thereunder would have been committed, the like offence shall be deemed to have been committed in respect of that aircraft.

| | | | | |
|----------|---|---|------------|------------|
| Section: | 7 | Certificate of airworthiness to be in force | 36 of 1999 | 01/07/1997 |
|----------|---|---|------------|------------|

Remarks:

Adaptation amendments retroactively made - see 36 of 1999 s. 3

PART III

AIRWORTHINESS AND EQUIPMENT OF AIRCRAFT

(1) An aircraft shall not fly unless there is in force in respect thereof a certificate of airworthiness duly issued or rendered valid under the law of the country in which the aircraft is registered, and any conditions subject to which the certificate was issued or rendered valid are complied with:

Provided that the foregoing prohibition shall not apply to flights, beginning and ending in Hong Kong without passing over any other country, of:

- (a) a glider, if it is not being used for the public transport of passengers or aerial work other than aerial work which consists of the giving of instruction in flying or the conducting of flying tests in a glider owned or operated by a flying club of which the person giving the instruction or conducting the test and the person receiving the instruction or undergoing the test are both members;
- (b) a balloon, if it is not being used for the public transport of passengers;

- (c) a kite;
- (d) an aircraft flying in accordance with the "A Conditions" or the "B Conditions" set forth in Schedule 2 to this Order; and
- (e) an aircraft flying in accordance with the conditions of a permit to fly issued by the Chief Executive in respect of that aircraft. (36 of 1999 s. 3)

(2) In the case of an aircraft registered in Hong Kong the certificate of airworthiness referred to in paragraph (1) of this Article shall be a certificate issued or rendered valid in accordance with the provisions of Article 8 of this Order.

| | | | | |
|----------|---|--|------------|------------|
| Section: | 8 | Issue, renewal, etc., of certificates of airworthiness | 36 of 1999 | 01/07/1997 |
|----------|---|--|------------|------------|

Remarks:

Adaptation amendments retroactively made - see 36 of 1999 s. 3

(1) The Chief Executive shall issue in respect of any aircraft a certificate of airworthiness if he is satisfied that the aircraft is fit to fly having regard to:

- (a) the design, construction, workmanship and materials of the aircraft (including in particular any engines fitted therein), and of any equipment carried in the aircraft which he considers necessary for the airworthiness of the aircraft; and
- (b) the results of flying trials, and such other tests of the aircraft as he may require:

Provided that, if the Chief Executive has issued a certificate of airworthiness in respect of an aircraft which, in his opinion, is a prototype aircraft or a modification of a prototype aircraft, he may dispense with flying trials in the case of any other aircraft if he is satisfied that it conforms to such prototype or modification.

(2) Every certificate of airworthiness shall specify such categories as are, in the opinion of the Chief Executive, appropriate to the aircraft in accordance with Schedule 3 to this Order and the certificate shall be issued subject to the condition that the aircraft shall be flown only for the purposes indicated in the said Schedule in relation to those categories.

(3) The Chief Executive may issue the certificate of airworthiness subject to such other conditions relating to the airworthiness of the aircraft as he thinks fit.

(4) The certificate of airworthiness may designate the performance group to which the aircraft belongs for the purposes of the requirements referred to in Article 29(1) of this Order.

(5) The Chief Executive may, subject to such conditions as he thinks fit, issue a certificate of validation rendering valid for the purposes of this Order a certificate of airworthiness issued in respect of any aircraft under the law of any country other than Hong Kong.

(6) Subject to the provisions of this Article and of Article 62 of this Order, a certificate of airworthiness or validation issued under this Article shall remain in force for such period as may be specified therein, and may be renewed from time to time by the Chief Executive for such further period as he thinks fit.

(7) A certificate of airworthiness or a certificate of validation issued in respect of an aircraft shall cease to be in force:

- (a) if the aircraft, or such of its equipment as is necessary for the airworthiness of the aircraft, is overhauled, repaired or modified, or if any part of the aircraft or of such equipment is removed or is replaced, otherwise than in a manner and with material of a type approved by the Chief Executive either generally or in relation to a class of aircraft or to the particular aircraft;
- (b) until the completion of any inspection of the aircraft or of any such equipment as aforesaid, being an inspection made for the purpose of ascertaining whether the aircraft remains airworthy and:
 - (i) classified as mandatory by the Chief Executive;
 - (ii) required by a maintenance schedule approved by the Chief Executive in relation to that aircraft; or

- (c) until the completion to the satisfaction of the Chief Executive of any modification of the aircraft or of any such equipment as aforesaid, being a modification required by the Chief Executive for the purpose of ensuring that the aircraft remains airworthy.

(8) Nothing in this Order shall oblige the Chief Executive to accept an application for the issue of a certificate of airworthiness or validation or for the variation or renewal of any such certificate when the application is not supported by such reports from such approved persons as the Chief Executive may specify (either generally or in a particular case or class of cases).

(36 of 1999 s. 3)

| | | | | |
|----------|---|-----------------------------------|------------|------------|
| Section: | 9 | Certificate of maintenance review | 36 of 1999 | 09/07/1999 |
|----------|---|-----------------------------------|------------|------------|

Remarks:

Adaptation amendments retroactively made - see 36 of 1999 s. 3

(1) An aircraft registered in Hong Kong in respect of which a certificate of airworthiness in either the transport or in the aerial work category is in force shall not fly unless:

- (a) the aircraft (including in particular its engines), together with its equipment and radio station, is maintained in accordance with a maintenance schedule approved by the Chief Executive in relation to that aircraft; and (36 of 1999 s. 3)
- (b) there is in force a certificate (in this Order referred to as a "certificate of maintenance review") issued in respect of the aircraft in accordance with the provisions of this Article and such certificate shall certify the date on which the maintenance review was carried out and the date thereafter when the next review is due.

(2) The approved maintenance schedule referred to in paragraph (1) of this Article shall specify the occasions on which a review must be carried out for the purposes of issuing a certificate of maintenance review.

(3) A certificate of maintenance review may be issued for the purposes of this Article only by:

- (a) the holder of an aircraft maintenance engineer's licence:
 - (i) granted under this Order being a licence which entitles him to issue that certificate; or
 - (ii) granted under the law of a country other than Hong Kong and rendered valid under this Order in accordance with the privileges endorsed on the licence;
 - (iii) (Repealed 36 of 1999 s. 3)
- (b) a person whom the Chief Executive has authorized to issue a certificate of maintenance review in a particular case, and in accordance with that authority; or
- (c) a person approved by the Chief Executive as being competent to issue such certificates, and in accordance with that approval:

Provided that, in approving a maintenance schedule, the Chief Executive may direct that certificates of maintenance review relating to that schedule, or to any part thereof specified in its direction, may be issued only by the holder of such a licence as is so specified. (36 of 1999 s. 3)

(4) A person referred to in paragraph (3) of this Article shall not issue a certificate of maintenance review unless he has first verified that:

- (a) maintenance has been carried out on the aircraft in accordance with the maintenance schedule approved for that aircraft;
- (b) inspections and modifications required by the Chief Executive as provided in Article 8 of this Order have been completed as certified in the relevant certificate of release to service issued in accordance with Article 11 of this Order; (36 of 1999 s. 3)
- (c) defects entered in the technical log of the aircraft in accordance with Article 10 of this Order have been rectified or the rectification thereof has been deferred in

- accordance with procedures approved by the Chief Executive; and (36 of 1999 s. 3)
- (d) certificates of release to service have been issued in accordance with Article 11 of this Order;

and for this purpose the operator of the aircraft shall make available to that person such information as is necessary.

(5) A certificate of maintenance review shall be issued in duplicate. One copy of the most recently issued certificate shall be carried in the aircraft when Article 57 of this Order so requires, and the other shall be kept by the operator elsewhere than in the aircraft.

(6) Subject to the provisions of Article 61 of this Order, each certificate of maintenance review shall be preserved by the operator of the aircraft for a period of two years after it has been issued.

(7) For the purpose of this Article a "person" may include a body corporate.

| | | | | |
|----------|----|---------------|------------|------------|
| Section: | 10 | Technical log | 36 of 1999 | 01/07/1997 |
|----------|----|---------------|------------|------------|

Remarks:

Adaptation amendments retroactively made - see 36 of 1999 s. 3

(1) A technical log shall be kept in respect of an aircraft registered in Hong Kong being an aircraft in respect of which a certificate of airworthiness in either the transport or in the aerial work category is in force or in respect of any other aircraft when the Chief Executive so requires.

(2) At the end of every flight by an aircraft to which the provisions of this Article apply the commander of the aircraft shall enter:

- (a) the times when the aircraft took off and landed;
- (b) particulars of any defect which is known to him and which affects the airworthiness or safe operation of the aircraft, or if no such defect is known to him, an entry to that effect; and
- (c) such other particulars in respect of the airworthiness or operation of the aircraft as the Chief Executive may require;

in a technical log, or, in the case of an aircraft of which the maximum total weight authorised does not exceed 2730 kg and which is not operated by a person who is the holder of or is required by Article 6(1) of this Order to hold an air operator's certificate in such other record as the Chief Executive shall approve and he shall sign and date such entries:

Provided that in the case of a number of consecutive flights each of which begins and ends:

- (i) within the same period of 24 hours;
- (ii) at the same aerodrome, except where each such flight is for the purpose of dropping or projecting any material for agricultural, public health or similar purposes; and
- (iii) with the same person as commander of the aircraft;

the commander of an aircraft may, except where he becomes aware of a defect during an earlier flight, make the entries as aforesaid in a technical log at the end of the last of such consecutive flights.

(3) Upon the rectification of any defect which has been entered in a technical log in accordance with paragraph (2) of this Article a person issuing a certificate of release to service required by Article 11 of this Order in respect of that defect shall enter the certificate in the technical log in such a position as to be readily identifiable with the defect to which it relates.

(4) The technical log referred to in this Article shall be carried in the aircraft when Article 57 of this Order so requires and copies of the entries referred to in this Article shall be kept on the ground:

Provided that, in the case of an aeroplane of which the maximum total weight authorised does not exceed 2730 kg, or a helicopter, if it is not reasonably practicable for the copy of the technical log to be kept on the ground it may be carried in the aeroplane or helicopter, as the case may be, in a container approved by the Chief Executive for that purpose.

(5) Subject to the provisions of Article 61 of this Order, a technical log or such other approved record required by this Article shall be preserved by the operator of the aircraft to which it relates until a date two years after the aircraft has been destroyed or has been permanently withdrawn from use, or for such shorter period as the Chief Executive may permit in a particular case.

(36 of 1999 s. 3)

| | | | | |
|----------|----|--|------------|------------|
| Section: | 11 | Inspection, overhaul, repair, replacement and modification | 36 of 1999 | 09/07/1999 |
|----------|----|--|------------|------------|

Remarks:

Adaptation amendments retroactively made - see 36 of 1999 s. 3

(1) Except as provided in paragraph (2) of this Article an aircraft registered in Hong Kong, being an aircraft in respect of which a certificate of airworthiness issued or rendered valid under this Order is in force, shall not fly unless there is in force a certificate (in this Order referred to as a "certificate of release to service") issued in accordance with this Article if the aircraft or any part of the aircraft or such of its equipment as is necessary for the airworthiness of the aircraft has been overhauled, repaired, replaced, modified, maintained, or has been inspected as provided in Article 8(7)(b) of this Order, as the case may be:

Provided that if a repair or replacement of a part of an aircraft or its equipment is carried out when the aircraft is at such a place that it is not reasonably practicable:

(a) for the repair or replacement to be carried out in such a manner that a certificate of release to service can be issued under this Article in respect thereof; or

(b) for such certificate to be issued while the aircraft is at that place;

it may fly to a place at which such certificate can be issued, being the nearest place:

(i) to which the aircraft can, in the reasonable opinion of the commander thereof, safely fly by a route for which it is properly equipped; and

(ii) to which it is reasonable to fly having regard to any hazards to the liberty or health of any person on board;

and in such case the commander of the aircraft shall cause written particulars of the flight, and the reasons for making it, to be given to the Chief Executive within ten days thereafter.

(2) Nothing in paragraph (1) of this Article shall require a certificate of release to service to be in force in respect of an aircraft of which the maximum total weight authorized does not exceed 2730 kg and in respect of which a certificate of airworthiness of the special category is in force, unless the Chief Executive gives a direction to the contrary in a particular case.

(3) Nothing in paragraph (1) of this Article shall prevent an aircraft in respect of which there is in force a certificate of airworthiness in the private or special categories and whose maximum total weight authorised does not exceed 2730 kg from flying if the only repairs or replacements in respect of which a certificate of release to service is not in force are of such a description as are specified in Regulation 15 in Schedule 15 to this Order and have been carried out personally by the owner or operator of the aircraft being the holder of a pilot's licence granted or rendered valid under this Order. In that event the owner or operator, as the case may be, of the aircraft, shall keep in the aircraft log book kept in respect of the aircraft pursuant to Article 15 of this Order a record which identifies the repair or replacement and shall sign and date the entries and, subject to the provisions of Article 61 of this Order, shall preserve the log book for the period specified in Article 15 of this Order. Any equipment or parts used in carrying out such repairs or replacements shall be of a type approved by the Chief Executive whether generally or in relation to a class of aircraft or one particular aircraft.

(4) Neither:

(a) equipment provided in compliance with Schedule 5 to this Order (except paragraph (3) thereof); nor

(b) radio apparatus provided for use in an aircraft or in any survival craft carried in an

aircraft, whether or not such apparatus is provided in compliance with this Order or any regulations made thereunder;
shall be installed or placed on board for use in an aircraft registered in Hong Kong after being overhauled, repaired, modified or inspected, unless there is in force in respect thereof at the time when it is installed or placed on board a certificate of release to service issued in accordance with this Article.

- (5) A certificate of release to service shall:
- (a) certify that the aircraft or any part thereof or its equipment has been overhauled, repaired, replaced, modified or maintained, as the case may be in a manner and with material of a type approved by the Chief Executive either generally or in relation to a class of aircraft or the particular aircraft and shall identify the overhaul, repair, replacement, modification or maintenance to which the certificate relates and shall include particulars of the work done; or
 - (b) certify in relation to any inspection required by the Chief Executive that the aircraft or the part thereof or its equipment, as the case may be, has been inspected in accordance with the requirements of the Chief Executive and that any consequential repair, replacement or modification has been carried out as aforesaid.
- (6) A certificate of release to service may be issued for the purposes of this Article only by:
- (a) the holder of an aircraft maintenance engineer's licence:
 - (i) granted under this Order, being a licence which entitles him to issue that certificate; or
 - (ii) granted under the law of a country other than Hong Kong and rendered valid under this Order, in accordance with the privileges endorsed on the licence;
 - (iii) (Repealed 36 of 1999 s. 3)
 - (b) the holder of an aircraft maintenance engineer's licence or authorisation as such an engineer granted or issued by or under the law of any Contracting State other than Hong Kong in which the overhaul, repair, replacement, modification or inspection has been carried out, but only in respect of aircraft of which the maximum total weight authorised does not exceed 2730 kg and in accordance with the privileges endorsed on the licence;
 - (c) a person approved by the Chief Executive as being competent to issue such certification, and in accordance with that approval;
 - (d) a person whom the Chief Executive has authorised to issue the certificate in a particular case, and in accordance with that authority; or
 - (e) in relation only to the adjustment and compensation of direct reading magnetic compasses, the holder of an Airline Transport Pilot's Licence (Aeroplanes) or a Flight Navigator's Licence granted or rendered valid under this Order.

(7) Subject to the provisions of Article 61 of this Order, a certificate of release to service shall be preserved by the operator of the aircraft to which it relates for the period of time for which he is required to preserve the log book relating to the same part of the aircraft or to the same equipment or apparatus as the case may be.

(8) In this Article, the expression "repair" includes in relation to a compass the adjustment and compensation thereof and the expression "repaired" shall be construed accordingly.

(9) For the purpose of this Article "a person" may include a body corporate.

(36 of 1999 s. 3)

| | | | | |
|----------|----|------------------------------------|------------|------------|
| Section: | 12 | Licensing of maintenance engineers | 36 of 1999 | 01/07/1997 |
|----------|----|------------------------------------|------------|------------|

Remarks:

Adaptation amendments retroactively made - see 36 of 1999 s. 3

(1) The Chief Executive shall grant aircraft maintenance engineer's licences, subject to such conditions as he thinks fit, upon his being satisfied that the applicant is a fit person to hold the

licence and has furnished such evidence and passed such examinations and tests as the Chief Executive may require of him for the purpose of establishing that he has sufficient knowledge, experience, competence and skill in aeronautical engineering.

(2) An aircraft maintenance engineer's licence shall authorise the holder, subject to such conditions as may be specified in the licence, to issue:

- (a) certificates of a maintenance review in respect of such aircraft as may be so specified;
- (b) certificates of release to service in respect of such overhauls, repairs, replacements, modifications, maintenance and inspections of such aircraft and such equipment as may be so specified; or
- (c) certificates of fitness for flight under "A Conditions" in respect of such aircraft as may be so specified.

(3) A licence shall, subject to the provisions of Article 62 of this Order, remain in force for the period specified therein, not exceeding five years, but may be renewed by the Chief Executive from time to time upon his being satisfied that the applicant is a fit person and is qualified as aforesaid.

(4) The Chief Executive may issue a certificate rendering valid for the purposes of this Order any licence as an aircraft maintenance engineer granted under the law of any country other than Hong Kong. Such certificate may be issued subject to such conditions, and for such period, as the Chief Executive thinks fit.

(5) Upon receiving a licence granted under this Article, the holder shall forthwith sign his name thereon in ink with his ordinary signature.

(6) Without prejudice to any other provision of this Order the Chief Executive may, for the purpose of this Article, either absolutely or subject to such conditions as he thinks fit:

- (a) approve any course of training or instruction;
- (b) authorize a person to conduct such examinations or tests as he may specify;
- (c) approve a person to provide or conduct any course of training or instruction; and
- (d) approve a person as qualified to furnish reports to him and to accept such reports.

(36 of 1999 s. 3)

| | | | | |
|----------|----|-----------------------------|------------|------------|
| Section: | 14 | Radio equipment of aircraft | 36 of 1999 | 01/07/1997 |
|----------|----|-----------------------------|------------|------------|

Remarks:

Adaptation amendments retroactively made - see 36 of 1999 s. 3

(1) An aircraft shall not fly unless it is so equipped with radio and radio navigation equipment as to comply with the law of the country in which the aircraft is registered and to enable communications to be made and the aircraft to be navigated, in accordance with the provisions of this Order including, in particular, Schedule 15 hereto.

(2) Without prejudice to paragraph (1) of this Article, the aircraft shall be equipped with radio and radio navigation equipment in accordance with Schedule 6 to this Order.

(3) In any particular case the Chief Executive may direct that an aircraft registered in Hong Kong shall carry such additional or special radio or radio navigation equipment as he may specify for the purpose of facilitating the navigation of the aircraft, the carrying out of search and rescue operations or the survival of the persons carried in the aircraft. (36 of 1999 s. 3)

(4) Subject to such exceptions as may be prescribed the radio and radio navigation equipment provided in compliance with this Article in an aircraft registered in Hong Kong shall always be maintained in serviceable condition.

(5) All radio and radio navigation equipment installed in an aircraft registered in Hong Kong or carried on such an aircraft for use in connection with the aircraft (whether or not in compliance with this Order or any regulations made thereunder) shall be of a type approved by the Chief Executive in relation to the purpose for which it is to be used, and shall be installed in a manner approved by the Chief Executive. Neither the equipment nor the manner in which it is

installed shall be modified except with the approval of the Chief Executive. (36 of 1999 s. 3)

| | | | | |
|----------|----|---------------------------------|------------|------------|
| Section: | 18 | Composition of crew of aircraft | 36 of 1999 | 01/07/1997 |
|----------|----|---------------------------------|------------|------------|

Remarks:

Adaptation amendments retroactively made - see 36 of 1999 s. 3

PART IV

AIRCRAFT CREW AND LICENSING

(1) An aircraft shall not fly unless it carries a flight crew of the number and description required by the law of the country in which it is registered.

(2) An aircraft registered in Hong Kong shall carry a flight crew adequate in number and description to ensure the safety of the aircraft and of at least the number and description specified in the certificate of airworthiness issued or rendered valid under this Order or, if no certificate of airworthiness is required under this Order to be in force, the certificate of airworthiness, if any, last in force under this Order, in respect of that aircraft.

(3) (a) A flying machine registered in Hong Kong and flying for the purpose of public transport having a maximum total weight authorized exceeding 5700 kg, shall carry not less than two pilots as members of the flight crew thereof.

(b) An aeroplane registered in Hong Kong and flying for the purpose of public transport in circumstances where the aircraft commander is required to comply with Instrument Flight Rules and having a maximum total weight authorized of 5700 kg, or less and powered by:-

- (i) one or more turbine jets;
- (ii) one or more turbine propeller engines and provided with a means of pressurizing the personnel compartments;
- (iii) two or more turbine propeller engines and certificated to carry more than nine passengers;
- (iv) two or more turbine propeller engines and certificated to carry fewer than ten passengers and not provided with a means of pressurizing the personnel compartments unless it is equipped with an auto-pilot which has been approved by the Chief Executive for the purposes of this Article and which is serviceable on take-off; or
- (v) two or more piston engines unless it is equipped with an auto-pilot which has been approved by the Chief Executive for the purposes of this Article and which is serviceable on take-off;

shall carry not less than two pilots as members of the flight crew thereof:

Provided that an aeroplane powered by two or more turbine propeller engines and certificated to carry fewer than ten passengers or an aeroplane powered by two or more piston engines and equipped with an appropriate auto-pilot shall not be required to carry two pilots notwithstanding that before take-off the approved auto-pilot is found to be unserviceable if the aeroplane flies in accordance with arrangements approved by the Chief Executive.

(4) An aircraft registered in Hong Kong engaged on a flight for the purpose of public transport shall carry:

- (a) a flight navigator as a member of the flight crew; or
- (b) navigational equipment approved by the Chief Executive and used in accordance with any conditions subject to which that approval may have been given;

if on the route or any diversion therefrom, being a route or diversion planned before take-off, the aircraft is intended to be more than 500 nautical miles from the point of take-off measured along the route to be flown, and to pass over part of an area specified in Schedule 8 to this Order. The flight navigator carried in compliance with this Article shall be carried in addition to any person

who is carried in accordance with this Article to perform other duties.

(5) An aircraft registered in Hong Kong which is required by the provisions of Article 14 of this Order to be equipped with radio communication apparatus shall carry a flight radio operator as a member of the flight crew, who, if he is required to operate radiotelegraph apparatus, shall be carried in addition to any other person who is carried in accordance with this Article to perform other duties.

(6) If it appears to him to be expedient to do so in the interests of safety, the Chief Executive may direct any particular operator of any aircraft registered in Hong Kong that the aircraft operated by him or any such aircraft shall not fly in such circumstances as the Chief Executive may specify unless those aircraft carry in addition to the flight crew required to be carried therein by the foregoing provisions of this Article such additional persons as members of the flight crew as he may specify in the direction.

(7) (a) This paragraph applies to any flight for the purpose of public transport by an aircraft registered in Hong Kong:

- (i) on which is carried twenty or more passengers; or
- (ii) which may in accordance with its certificate of airworthiness carry more than thirty-five passengers and on which at least one passenger is carried.

(b) The crew of an aircraft on a flight to which this paragraph applies shall include cabin attendants carried for the purposes of performing in the interests of the safety of passengers, duties to be assigned by the operator or the commander of the aircraft but who shall not act as members of the flight crew.

(c) On a flight to which this paragraph applies, there shall be carried not less than one cabin attendant for every fifty, or fraction of fifty passenger seats installed in the aircraft:

Provided that the number of cabin attendants calculated in accordance with this subparagraph need not be carried where the Chief Executive has granted written permission to the operator to carry a lesser number on that flight and the operator carries the number specified in that permission and complies with any other terms and conditions subject to which such permission is granted.

(8) If it appears to him to be expedient to do so in the interests of safety, the Chief Executive may direct any particular operator of any aircraft registered in Hong Kong that the aircraft operated by him or any such aircraft shall not fly in such circumstances as the Chief Executive may specify unless those aircraft carry in addition to the cabin attendants required to be carried therein by the foregoing provisions of this Article such additional persons as cabin attendants as he may specify in the direction.

(36 of 1999 s. 3)

| | | | | |
|----------|----|--|------------|------------|
| Section: | 19 | Members of flight crew-requirement of licences | 36 of 1999 | 01/07/1997 |
|----------|----|--|------------|------------|

Remarks:

Adaptation amendments retroactively made - see 36 of 1999 s. 3

(1) Subject to the provisions of this Article, a person shall not act as a member of the flight crew of an aircraft registered in Hong Kong unless he is the holder of an appropriate licence granted or rendered valid under this Order:

Provided that a person may within Hong Kong without being the holder of such a licence-

(a) act as a flight radiotelephony operator if-

- (i) he does so as the pilot of a glider not flying for the purpose of public transport or aerial work, or as a person being trained in an aircraft registered in Hong Kong to perform duties as a member of the flight crew of an aircraft; and

- (ii) he is authorized to operate the radiotelephony station by the holder of the

- licence granted in respect of that station under any enactment; and
 - (iii) messages are transmitted only for the purposes of instruction, or of the safety or navigation of the aircraft; and
 - (iv) messages are transmitted only on a frequency exceeding 60 MHz assigned by the Chief Executive for use on flights on which a flight radiotelephony operator acts in one of the capacities specified in paragraph (i) of this proviso; and (36 of 1999 s. 3)
 - (v) the transmitter is pre-set to one or more of the frequencies so assigned and cannot be adjusted in flight to any other frequency; and
 - (vi) the operation of the transmitter requires the use only of external switches; and
 - (vii) the stability of the frequency radiated is maintained automatically by the transmitter;
- (b) subject to the provisions of Article 20(8) of this Order, act as pilot in command of an aircraft for purpose of becoming qualified for the grant or renewal of a pilot's licence or the inclusion or variation of any rating in a pilot's licence if-
- (i) he is at least 17 years of age; and
 - (ii) he is the holder of a valid medical certificate to the effect that he is fit so to act issued by a person approved by the Chief Executive; and (36 of 1999 s. 3)
 - (iii) he complies with any conditions subject to which that medical certificate was issued; and
 - (iv) no other person is carried in the aircraft; and
 - (v) the aircraft is not flying for the purpose of public transport or aerial work other than aerial work which consists of the giving of instruction in flying or the conducting of flying tests; and
 - (vi) he so acts in accordance with instructions given by a person holding a pilot's licence granted under this Order being a licence which includes a flying instructor's rating or an assistant flying instructor's rating entitling him to give instruction in flying the type of aircraft being flown;
- (c) subject to the provisions of Article 20(8) of this Order, act as pilot of an aircraft in respect of which the flight crew required to be carried by or under this Order does not exceed one pilot for the purpose of becoming qualified for the grant or renewal of a pilot's licence or the inclusion or variation of any rating in a pilot's licence if-
- (i) the aircraft is not flying for the purpose of public transport or aerial work other than aerial work which consists of the giving of instruction in flying or the conducting of flying tests; and
 - (ii) he so acts in accordance with instructions given by a person holding a pilot's licence granted under this Order being a licence which includes a flying instructor's rating or an assistant flying instructor's rating entitling him to give instruction in flying the type of aircraft being flown; and
 - (iii) the aircraft is fitted with dual controls and he is accompanied in the aircraft by the said instructor who is seated at the other set of controls or the aircraft is fitted with controls designed for and capable of use by two persons and he is accompanied in the aircraft by the said instructor who is seated so as to be able to use the controls;
- (d) subject to the provisions of Article 20(8) of this Order, act as pilot in command of an aircraft at night if-
- (i) he is the holder of an appropriate licence granted or rendered valid under this Order in all respects save that the licence does not include an instrument rating and he has not within the immediately preceding thirteen months carried out as pilot in command not less than five take-offs and landings at a time when the depression of the centre of the sun was not less than 12° below the horizon;
 - (ii) he so acts in accordance with instructions given by a person holding a pilot's

licence granted under this Order being a licence which includes a flying instructor's rating or an assistant flying instructor's rating entitling him to give instruction in flying the type of aircraft being flown by night;

- (iii) no person other than that specified in sub-paragraph (ii) above is carried; and
- (iv) the aircraft is not flying for the purpose of public transport or aerial work other than aerial work which consists of the giving of instruction in flying or the conducting of flying tests.

(2) Subject as aforesaid, a person shall not act as a member of the flight crew required by or under this Order to be carried in an aircraft registered in a country other than Hong Kong unless-

- (a) in the case of an aircraft flying for the purpose of public transport or aerial work he is the holder of an appropriate licence granted or rendered valid under the law of the country in which the aircraft is registered; or
- (b) in the case of any other aircraft, he is the holder of an appropriate licence granted or rendered valid under the law of the country in which the aircraft is registered or under this Order, and the Chief Executive does not in the particular case give a direction to the contrary. (36 of 1999 s. 3)

(3) For the purposes of this Article, a licence granted under the law of a Contracting State other than Hong Kong purporting to authorize the holder thereof to act as a member of the flight crew of an aircraft, not being a licence purporting to authorize him to act as a student pilot only, shall, unless the Chief Executive in the particular case gives a direction to the contrary, be deemed to be a licence rendered valid under this Order but does not entitle the holder- (36 of 1999 s. 3)

- (a) to act as a member of the flight crew of any aircraft flying for the purpose of public transport or aerial work or on any flight in respect of which he receives remuneration for his services as a member of the flight crew; or
- (b) in the case of a pilot's licence, to act on any flight as pilot of any aircraft flying in controlled airspace in circumstances requiring compliance with the Instrument Flight Rules or to give any instruction in flying.

(4) Notwithstanding the provisions of paragraph (1) of this Article, a person may, unless the certificate of airworthiness in force in respect of the aircraft otherwise requires, act as pilot of an aircraft registered in Hong Kong for the purpose of undergoing training or tests for the grant or renewal of a pilot's licence or for the inclusion, renewal or extension of a rating therein without being the holder of an appropriate licence, if the following conditions are complied with:

- (a) no other person shall be carried in the aircraft or in an aircraft being towed thereby except a person carried as a member of the flight crew in compliance with this Order, a person authorized by the Chief Executive to witness the aforesaid training or tests or to conduct the aforesaid tests, or, if the pilot in command of the aircraft is the holder of an appropriate licence, a person carried for the purpose of being trained or tested as a member of the flight crew of an aircraft; and (36 of 1999 s. 3)
- (b) the person acting as the pilot of the aircraft without being the holder of an appropriate licence either-
 - (i) within the period of 6 months immediately preceding was serving as a qualified pilot of aircraft in any of Her Majesty's naval, military or air forces, and his physical condition has not, so far as he is aware, so deteriorated during that period as to render him unfit for the licence for which he intends to qualify; or
 - (ii) holds a pilot's, a flight navigator's or a flight engineer's licence granted or rendered valid under this Order and the purpose of the training or test is to enable him to qualify under this Order for the grant of a pilot's licence or for the inclusion of an additional type in the aircraft rating in his licence and he acts under the supervision of a person who is the holder of an appropriate licence.

(5) Notwithstanding the provisions of paragraph (1) of this Article a person may act as a member of the flight crew (otherwise than as a pilot) of an aircraft registered in Hong Kong for the purposes of undergoing training or tests for the grant or renewal of a flight navigator's or a flight engineer's licence or for the inclusion, renewal or extension of a rating thereon, without being the

holder of an appropriate licence if he acts under supervision and in the presence of another person who is the holder of the type of licence or rating for which the person undergoing the training or tests is being trained or tested.

(6) Notwithstanding the provisions of paragraph (1) of this Article, a person may act as a member of the flight crew of an aircraft registered in Hong Kong without being the holder of an appropriate licence if, in so doing, he is acting in the course of his duty as a member of any of Her Majesty's naval, military or air forces.

(7) An appropriate licence for the purposes of this Article means a licence which entitles the holder to perform the functions which he undertakes in relation to the aircraft concerned and the flight on which it is engaged.

(8) This Article shall not require a licence to be held by a person by reason of his acting as a member of the flight crew of a glider unless:

- (a) he acts as a flight radio operator, or
- (b) the flight is for the purpose of public transport or aerial work, other than aerial work which consists of the giving of instruction in flying in a glider owned or operated by a flying club of which the person giving and the person receiving instruction are both members.

(9) Notwithstanding anything in this Article-

- (a) the holder of a licence granted or rendered valid under this Order, being a licence endorsed to the effect that the holder does not satisfy in full the relevant international standard, shall not act as a member of the flight crew of an aircraft registered in Hong Kong in or over the territory of a Contracting State other than Hong Kong, except in accordance with permission granted by the competent authorities of that State;
- (b) the holder of a licence granted or rendered valid under the law of a Contracting State other than Hong Kong, being a licence endorsed as aforesaid, shall not act as a member of the flight crew of any aircraft in or over Hong Kong except in accordance with permission granted by the Chief Executive, whether or not the licence is or is deemed to be rendered valid under this Order. (36 of 1999 s. 3)

| | | | | |
|----------|----|---|------------|------------|
| Section: | 20 | Grant, renewal and effect of Flight Crew Licences | 36 of 1999 | 01/07/1997 |
|----------|----|---|------------|------------|

Remarks:

Adaptation amendments retroactively made - see 36 of 1999 s. 3

- (1) (a) The Chief Executive may grant licences, subject to such conditions as he thinks fit, of any of the classes specified in Part A of Schedule 9 to this Order authorizing the holder to act as a member of the flight crew of an aircraft registered in Hong Kong, upon his being satisfied that the applicant is a fit person to hold the licence, and is qualified by reason of his knowledge, experience, competence, skill, physical and mental fitness to act in the capacity to which the licence relates, and for that purpose the applicant shall furnish such evidence and undergo such examinations and tests (including in particular medical examinations) and undertake such courses of training as the Chief Executive may require of him.
- (b) A licence of any class shall not be granted to any person who is under the minimum age specified for that class of licence in Part A of the said Schedule.
- (c) A licence granted under this Article shall not be valid unless it bears thereon the ordinary signature of the holder in ink.
- (d) Subject to paragraph (1)(a) of this Article and to the provisions of Article 62 of this Order, a licence shall remain in force for the period indicated in the licence not exceeding the period specified in respect of a licence of that class in the said Schedule, and may be renewed by the Chief Executive from time to time upon his

being satisfied that the applicant is a fit person and qualified as aforesaid. If no period is indicated in the licence, it shall remain in force subject as aforesaid, for the lifetime of the holder.

Provided that, until 1st December 1996, the said Part A of Schedule 9 shall be applied as if-

- (i) in the privileges of the Commercial Pilot's Licence (Aeroplanes), proviso (e) to paragraph (2), the proviso to paragraph (3) and paragraph (4) were omitted;
- (ii) the privileges of the Airline Transport Pilot's Licence (Aeroplanes) were amended to read-"the holder of the licence shall be entitled to exercise the privileges of a Commercial Pilot's Licence (Aeroplanes) except that for proviso (d) to paragraph (2) of those privileges, there shall be substituted-
 - (d) he shall not at any time after he attains the age of 60 years fly such an aeroplane for the purpose of public transport if its maximum total weight authorized exceeds 20000 kg. ";
- (iii) in the privileges of the Commercial Pilot's Licence (Helicopters and Gyroplanes), proviso (e) to paragraph (2), the proviso to paragraph (3) and paragraph (4) were omitted; and
- (iv) in the privileges of the Airline Transport Pilot's Licence (Helicopters and Gyroplanes), all the words after "shall not apply" were omitted.

(2) The Chief Executive may include in a licence a rating, subject to such conditions as he thinks fit, of any of the classes specified in Part B of the said Schedule, upon his being satisfied that the applicant is qualified as aforesaid to act in the capacity to which the rating relates, and such rating shall be deemed to form part of the licence.

(3) Subject to any conditions of the licence and to the provisions of this Order, a licence of any class shall entitle the holder to perform the functions specified in respect of that licence in Part A of the said Schedule under the heading "privileges", and a rating of any class shall entitle the holder of the licence in which such rating is included to perform the functions specified in respect of that rating in Part B of the said Schedule.

- (4) (a) Subject to the provisions of sub-paragraph (c) of this paragraph, the holder of a pilot's licence or a flight engineer's licence shall not be entitled to exercise the privileges of an aircraft rating contained in the licence on a flight unless the licence bears a valid certificate of test or a valid certificate of experience, which certificate shall in either case be appropriate to the functions he is to perform on that flight in accordance with Part C of the said Schedule and shall otherwise comply with that Part:

Provided that the holder of a Private Pilot's Licence (Balloons and Airships) or a Commercial Pilot's Licence (Balloons) shall be entitled to exercise the privileges of an aircraft rating contained in the licence on a flight when the licence does not bear such a certificate.

- (b) The holder of a flight navigator's licence shall not be entitled to perform functions on a flight to which Article 18(4) of this Order applies unless the licence bears a valid certificate of experience which certificate shall be appropriate to the functions he is to perform on that flight in accordance with Part C of Schedule 9 and shall otherwise comply with that Part.
- (c) In any case where the Private Pilot's Licence is in such a form that it is not possible to include certificates therein, the holder of such a licence shall not be entitled to exercise the privileges of an aircraft rating contained in the licence on a flight unless the certificate of test or certificate of experience required by sub-paragraph (a) of this paragraph is included in the personal flying log book required to be kept by him under Article 22 of this Order.

(5) A person shall not be entitled to perform the functions to which an instrument rating (aeroplanes), an instrument rating (helicopters), a flying instructor's rating or an assistant flying instructor's rating relates unless his licence bears a valid certificate of test which certificate shall be appropriate to the functions to which the rating relates in accordance with Part C of the said Schedule and shall otherwise comply with that Part.

- (6) A person who, on the last occasion when he took a test for the purposes of paragraphs

(4) or (5) of this Article, failed that test shall not be entitled to fly in the capacity for which that test would have qualified him had he passed it.

- (7) (a) The holder of a licence, other than a flight radiotelephony operator's licence, granted under this Article shall not be entitled to perform any of the functions to which his licence relates unless it includes a valid medical certificate.
- (b) Every applicant for or holder of such a licence shall upon such occasions as the Chief Executive may require submit himself to medical examination by a person approved by the Chief Executive either generally or in a particular case or class of case who shall make a report to the Chief Executive in such form as the Chief Executive may require.
- (c) Where the medical examination referred to in sub-paragraph (b) of this paragraph has been conducted in Hong Kong, the Chief Executive or any person approved by him as competent to do so may, on the basis thereof, issue a medical certificate subject to such conditions as he thinks fit to the effect that he has assessed the holder of the licence as fit to perform the functions to which the licence relates. The certificate shall without prejudice to paragraph (8) of this Article, be valid for such period as is therein specified and shall be deemed to form part of the licence.
- (d) Where the medical examination is conducted outside Hong Kong, the person conducting the examination shall, in addition to making a report to the Chief Executive, issue a certificate certifying, if such is, in his opinion, the case, that the holder of the licence is fit to perform the functions to which the licence relates and the said certificate may be deemed by the Chief Executive to be a medical certificate for the purposes of this Article, and if so shall be valid for such period as may be specified therein in writing by the person conducting the examination.
- (8) (a) A person shall not be entitled to act as a member of the flight crew of an aircraft registered in Hong Kong if he knows or suspects that his physical or mental condition renders him temporarily or permanently unfit to perform such functions or to act in such capacity.
- (b) Every holder of a medical certificate issued under Article 19 or 20 of this Order who-
- (i) suffers any personal injury involving incapacity to undertake his functions as a member of the flight crew; or
- (ii) suffers any illness involving incapacity to undertake those functions throughout a period of 20 days or more; or
- (iii) in the case of a woman, has reason to believe that she is pregnant: shall inform the Chief Executive in writing of such injury, illness or pregnancy, as soon as possible in the case of injury or pregnancy, and as soon as the period of 20 days has elapsed in the case of illness. The medical certificate shall be deemed to be suspended upon the occurrence of such injury or the elapse of such period of illness or the confirmation of the pregnancy, and-
- (aa) in the case of injury or illness the suspension shall cease upon the holder being medically examined under arrangements made by the Chief Executive and pronounced fit to resume his functions as a member of the flight crew or upon the Chief Executive exempting, subject to such conditions as he thinks fit, the holder from the requirement of a medical examination; and
- (bb) in the case of pregnancy, the suspension may be lifted by the Chief Executive for such period and subject to such conditions as he thinks fit and shall cease upon the holder being medically examined under arrangements made by the Chief Executive after the pregnancy has ended and pronounced fit to resume her functions as a member of the flight crew.

(9) Nothing in this Order shall prohibit the holder of a pilot's licence from acting as pilot of an aircraft having a maximum total weight authorized not exceeding 5700 kg when, with the permission of the Chief Executive, he is testing any person for the purposes of paragraphs (1), (2), (4) or (5) of this Article, notwithstanding that the type of aircraft in which the test is conducted is not specified in the aircraft rating included in his licence or that the licence or personal flying log

book, as the case may be, does not include a valid certificate of test or a valid certificate of experience in respect of the type of aircraft.

(10) Where any provision of Part C of Schedule 9 or Part B of Schedule 11 to this Order permits a test to be conducted in a flight simulator approved by the Chief Executive, that approval may be granted subject to such conditions as the Chief Executive thinks fit.

(11) Without prejudice to any other provision of this Order the Chief Executive may, for the purpose of this Article, either absolutely or subject to such conditions as he thinks fit-

- (a) approve any course of training or instruction;
- (b) authorize a person to conduct such examinations or tests as he may specify;
- (c) approve a person to provide any course of training or instruction; and
- (d) approve a person as qualified to furnish reports to him and to accept such reports.

(36 of 1999 s. 3)

| | | | |
|----------|----|--------------------------|------------|
| Section: | 22 | Personal flying log book | 30/06/1997 |
|----------|----|--------------------------|------------|

(1) Every Member of the flight crew of an aircraft registered in Hong Kong and every person who engages in flying for the purpose of qualifying for the grant or renewal of a licence under this Order shall keep a personal flying log book in which the following particulars shall be recorded-

- (a) the name and address of the holder of the log book;
- (b) particulars of the holder's licence (if any) to act as member of the flight crew of an aircraft;
- (c) the name and address of his employer (if any).

(2) Particulars of each flight during which the holder of the log book acted either as a member of the flight crew of an aircraft or for the purpose of qualifying for the grant or renewal of a licence under this Order as the case may be, shall be recorded in the log book at the end of each flight or as soon thereafter as is reasonably practicable, including-

- (a) the date, the places at which the holder embarked on and disembarked from the aircraft and the time spent during the course of a flight when he was acting in either capacity;
- (b) the type and registration mark of the aircraft;
- (c) the capacity in which the holder acted in flight;
- (d) particulars of any special conditions under which the flight was conducted, including night-flying and instrument flying; and
- (e) particulars of any test or examination undertaken whilst in flight.

(3) For the purposes of this Article, a helicopter shall be deemed to be in flight from the moment the helicopter first moves under its own power for the purpose of taking off until the rotors are next stopped.

(4) Particulars of any test or examination undertaken whilst in a flight simulator shall be recorded in the log book, including-

- (a) the date of the test or examination;
- (b) the type of simulator;
- (c) the capacity in which the holder acted; and
- (d) the nature of the test or examination.

| | | | |
|----------|----|-----------------------|------------|
| Section: | 23 | Instruction in flying | 30/06/1997 |
|----------|----|-----------------------|------------|

(1) A person shall not give any instruction in flying to which this Article applies unless-

- (a) he holds a licence, granted or rendered valid under this Order, entitling him to act as pilot in command of the aircraft for the purpose and in the circumstances under

which the instruction is to be given; and

- (b) his licence includes a flying instructor's rating or an assistant flying instructor's rating entitling the holder to give the instruction.

(2) This Article applies to instruction in flying given to any person flying or about to fly a flying machine or glider for the purpose of becoming qualified for-

- (a) the grant of a pilot's licence;
- (b) the inclusion or variation of any rating in his licence:

Provided that this Article shall not apply to any instruction if flying given to a person for the purpose of becoming qualified for the inclusion in his licence of an aircraft rating entitling him to act as pilot of a multi-engined aircraft, or of an aircraft of any class appearing in column 4 of the Table in Part A of Schedule 1 to this Order if that person has previously been entitled under the Order, or qualified in any of Her Majesty's naval, military or air forces, to act as pilot of multi-engined aircraft, or of an aircraft of that class as the case may be.

| | | | | |
|----------|----|-----------------|------------|------------|
| Section: | 26 | Training manual | 36 of 1999 | 01/07/1997 |
|----------|----|-----------------|------------|------------|

Remarks:

Adaptation amendments retroactively made - see 36 of 1999 s. 3

(1) The operator of every aircraft registered in Hong Kong and flying for the purpose of public transport shall:

- (a) make a training manual available to every person appointed by the operator to give or to supervise the training, experience, practice or periodical tests required under Article 27(2) of this Order; and
- (b) ensure that each copy of that training manual is kept up to date.

(2) Each training manual shall contain all such information and instructions as may be necessary to enable a person appointed by the operator to give or to supervise the training, experience, practice and periodical tests required under Article 27(2) of this Order to perform his duties as such including in particular information and instructions relating to the matters specified in Part C of Schedule 11 to this Order.

- (3) (a) An aircraft to which this Article applied shall not fly unless, not less than 30 days prior to such flight, the operator of the aircraft has furnished to the Chief Executive a copy of the whole of his training manual relating to the crew of that aircraft.
- (b) Any amendments or additions to the training manual shall be furnished to the Chief Executive by the operator before or immediately after they come into effect:

Provided that where an amendment or addition relates to training, experience, practice or periodical tests on an aircraft to which the training manual did not previously relate, that aircraft shall not fly for the purpose of public transport until the amendment or addition has been furnished to the Chief Executive.

- (c) Without prejudice to the foregoing sub-paragraphs the operator shall make such amendments or additions to the training manual as the Chief Executive may require for the purpose of ensuring the safety of the aircraft or of persons or property carried therein or the safety, efficiency or regularity of air navigation. (36 of 1999 s. 3)

| | | | | |
|----------|----|--|--|------------|
| Section: | 27 | Public transport-operator's responsibilities | | 30/06/1997 |
|----------|----|--|--|------------|

(1) The operator of an aircraft registered in Hong Kong shall not permit the aircraft to fly for the purpose of public transport without first-

- (a) designating from among the flight crew a pilot to be the commander of the aircraft for the flight; and

- (b) satisfying himself by every reasonable means that the aeronautical radio stations and navigational aids serving the intended route or any planned diversion therefrom are adequate for the safe navigation of the aircraft; and
- (c) satisfying himself by every reasonable means that the aerodromes at which it is intended to take-off or land and any alternate aerodrome at which a landing may be made are suitable for the purpose and in particular are adequately manned and equipped (including such manning and equipment as is specified in Regulation 14 in Schedule 15 to this Order) to ensure the safety of the aircraft and its passengers:

Provided that the operator of the aircraft shall not be required to satisfy himself as to the adequacy of fire-fighting, search, rescue or other services which are required only after the occurrence of an accident.

(2) The operator of an aircraft registered in Hong Kong shall not permit any person to be a member of the crew thereof during any flight for the purpose of public transport (except a flight for the sole purpose of training persons to perform duties in aircraft) unless such person has had the training, experience, practice and periodical tests specified in Part B of Schedule 11 to this Order in respect of the duties which he is to perform and unless the operator has satisfied himself that such person is competent to perform his duties, and in particular to use the equipment provided in the aircraft for that purpose. The operator shall maintain, preserve, produce and furnish information respecting records relating to the foregoing matters in accordance with Part B of the said Schedule 11.

(3) The operator of an aircraft registered in Hong Kong shall not permit any member of the flight crew thereof, during any flight for the purpose of the public transport of passengers, to simulate emergency manoeuvres and procedures which the operator has reason to believe will adversely affect the flight characteristics of the aircraft.

| | | | | |
|----------|----|---|------------|------------|
| Section: | 28 | Loading-public transport aircraft and suspended loads | 36 of 1999 | 01/07/1997 |
|----------|----|---|------------|------------|

Remarks:

Adaptation amendments retroactively made - see 36 of 1999 s. 3

(1) The operator of an aircraft registered in Hong Kong shall not cause or permit it to be loaded for a flight for the purpose of public transport, or any load to be suspended therefrom, except under the supervision of a person whom he has caused to be furnished with written instructions as to the distribution and securing of the load so as to ensure that-

- (a) the load may safely be carried on the flight; and
- (b) any conditions subject to which the certificate of airworthiness in force in respect of the aircraft was issued or rendered valid, being conditions relating to the loading of the aircraft, are complied with.

(2) The instructions shall indicate the weight of the aircraft prepared for service, that is to say the aggregate of the weight of the aircraft (shown in the weight schedule referred to in Article 16 of this Order) and the weight of such additional items in or on the aircraft as the operator thinks fit to include; and the instructions shall indicate the additional items included in the weight of the aircraft prepared for service, and show the position of the centre of gravity of the aircraft at that weight:

Provided that this paragraph shall not apply in relation to a flight if-

- (a) the aircraft's maximum total weight authorised does not exceed 1150 kg; or
- (b) the aircraft's maximum total weight authorised does not exceed 2730 kg and the flight is intended not to exceed 60 minutes in duration and is either-
 - (i) a flight solely for training persons to perform duties in an aircraft; or
 - (ii) a flight intended to begin and end at the same aerodrome; or
- (c) the aircraft is a helicopter the maximum total weight authorised of which does not exceed 3000 kg and the total seating capacity of which does not exceed five

persons.

(3) The operator of an aircraft shall not cause or permit it to be loaded in contravention of the instructions referred to in paragraph (1) of this Article.

(4) The person supervising the loading of the aircraft shall, before the commencement of any such flight, prepare and sign a load sheet in duplicate conforming to the requirements specified in Regulation 1 in Schedule 15 to this Order, and shall (unless he is himself the commander of the aircraft) submit the load sheet for examination by the commander of the aircraft who shall sign his name thereon:

Provided that the foregoing requirements of this paragraph shall not apply if-

(a) the load and the distributing and securing thereof upon the next intended flight are to be unchanged from the previous flight and the commander of the aircraft makes and signs an endorsement to that effect upon the load sheet for the previous flight, indicating the date of the endorsement, the place of departure upon the next intended flight and the next intended place of destination; or

(b) paragraph (2) of this Article does not apply in relation to the flight.

(5) One copy of the load sheet shall be carried in the aircraft when Article 57 of this Order so requires until the flights to which it relates have been completed and one copy of that load sheet and of the instructions referred to in this Article shall be preserved by the operator until the expiration of a period of six months thereafter and shall not be carried in the aircraft:

Provided that in the case of an aeroplane of which the maximum total weight authorized does not exceed 2730 kg, or a helicopter, if it is not reasonably practicable for the copy of the load sheet to be kept on the ground it may be carried in the aeroplane or helicopter, as the case may be, in a container approved by the Chief Executive for that purpose. (36 of 1999 s. 3)

(6) The operator of an aircraft registered in Hong Kong and flying for the purpose of the public transport of passengers shall not cause or permit baggage to be carried in the passenger compartment of the aircraft unless such baggage can be properly secured and, in the case of an aircraft capable of seating more than 30 passengers, such baggage shall not exceed the capacity of the spaces in the passenger compartment approved by the Chief Executive for the purpose of stowing baggage, unless carried in accordance with the terms of a written permission granted by the Chief Executive which permission may be granted subject to such conditions as the Chief Executive thinks fit. (36 of 1999 s. 3)

| | | | | |
|----------|----|---------------------------------------|------------|------------|
| Section: | 29 | Public transport-operating conditions | 36 of 1999 | 01/07/1997 |
|----------|----|---------------------------------------|------------|------------|

Remarks:

Adaptation amendments retroactively made - see 36 of 1999 s. 3

(1) An aircraft registered in Hong Kong shall not fly for the purpose of public transport, except for the sole purpose of training persons to perform duties in aircraft, unless the relevant requirements specified in Regulations 3 to 11 inclusive in Schedule 15 to this Order in respect of its weight and related performance and flight in specified meteorological conditions or at night are complied with.

(2) The assessment of the ability of an aircraft to comply with paragraph (1) of this Article shall be based on the information as to its performance contained in the certificate of airworthiness relating to the aircraft. In the event of the information given therein being insufficient for that purpose such assessment shall be based on the best information available to the commander of the aircraft.

(3) A flying machine registered in Hong Kong when flying over water for the purpose of public transport shall fly, except as may be necessary for the purpose of take-off or landing, at such an altitude as would enable the aircraft-

(a) if it has one engine only, in the event of the failure of that engine; or

(b) if it has more than one engine, in the event of the failure of one of those engines, and with the remaining engine or engines operating within the maximum

continuous power conditions specified in the certificate of airworthiness relating to the aircraft;

to reach a place at which it can safely land at a height sufficient to enable it to do so.

(4) Without prejudice to the provisions of paragraph (3) of this Article, an aeroplane in respect of which there is in force under this Order a certificate of airworthiness designating the aeroplane as being of performance group X shall not fly over water for the purpose of public transport so as to be more than 60 minutes flying time from the nearest shore, unless the aeroplane has more than two power units. For the purposes of this paragraph, flying time shall be calculated at normal cruising speed with one power unit inoperative.

(5) Without prejudice to the provisions of paragraph (3) of this Article, a helicopter in respect of which there is in force under this Order a certificate of airworthiness designating the helicopter as being of performance group B shall not fly over water for the purpose of public transport so as to be more than 20 seconds flying time from a point from which it can make an autorotative descent to land suitable for an emergency landing unless it is equipped with apparatus approved by the Chief Executive enabling it to land safely on water, but shall not so fly on any flight for more than three minutes except with the permission in writing of the Chief Executive and in accordance with any conditions subject to which that permission may have been given. For the purpose of this paragraph, flying time shall be calculated on the assumption that the helicopter is flying in still air at the speed specified in the certificate of airworthiness in force in respect of the helicopter as the speed for compliance with regulations governing flights over water. (36 of 1999 s. 3)

(6) Without prejudice to the provisions of paragraph (3) of this Article, a helicopter in respect of which there is in force under this Order a certificate of airworthiness designating the helicopter as being of performance group A2 shall not fly over water for the purpose of public transport for more than 15 minutes during any flight unless it is equipped with apparatus approved by the Chief Executive enabling it to land safely on water. (36 of 1999 s. 3)

(7) Notwithstanding the provisions of paragraph (1) of this Article a helicopter in respect of which there is in force under this Order a Certificate of Airworthiness designating the helicopter as being of performance Group A or Group A (Restricted) may fly for the purpose of public transport in accordance with the weight and related performance requirements prescribed for helicopters designated as being of:-

- (a) performance Group A (Restricted) in the case of a helicopter designated as being of performance Group A if:
 - (i) the maximum total weight authorised of the helicopter is less than 5700 kg; and
 - (ii) the total number of passengers carried on the helicopter does not exceed 15;or
- (b) performance Group B if:
 - (i) the maximum total weight authorised of the helicopter is less than 2730 kg; and
 - (ii) the total number of passengers carried does not exceed 9.

| | | | |
|----------|----|---|------------|
| Section: | 30 | Aircraft registered in Hong Kong-Aerodrome operating minima | 30/06/1997 |
|----------|----|---|------------|

- (1) (a) The operator of every aircraft to which Article 25 of this Order applies shall establish and include in the operations manual relating to the aircraft such particulars of aerodrome operating minima as are appropriate to every aerodrome of intended departure or landing and every alternate aerodrome:

Provided that in relation to any flight wherein it is not practicable to include such information in the operations manual the operator of the said aircraft shall, prior to the commencement of the flight, cause to be furnished, in writing, to the commander of the aircraft such particulars of the aerodrome operating minima as

are appropriate to every aerodrome of intended departure or landing and every alternate aerodrome and calculated in accordance with the specified method; and the operator shall cause a copy of the said particulars to be retained outside the aircraft for a minimum period of three months.

- (b) The operator of every such aircraft shall include in the operations manual relating to that aircraft such data and instructions as will enable the commander of the aircraft to calculate such aerodrome operating minima as are appropriate to aerodromes the use of which could not reasonably have been foreseen by the operator prior to the commencement of the flight.

(2) The aerodrome operating minima specified shall not, in respect of any aerodrome, be less favourable than any declared in respect of that aerodrome by the competent authority, unless that authority otherwise permits in writing.

(3) In establishing aerodrome operating minima for the purposes of this Article the operator of the aircraft shall take into account the following matters-

- (a) the type and performance and handling characteristics of the aircraft and any relevant conditions in its certificate of airworthiness; and
- (b) the composition of its crew; and
- (c) the physical characteristics of the relevant aerodrome and its surroundings; and
- (d) the dimensions of the runways which may be selected for use; and
- (e) whether or not there are in use at the relevant aerodrome any aids, visual or otherwise to assist aircraft in approach, landing or take-off, being aids which the crew of the aircraft are trained and equipped to use; the nature of any such aids that are in use; and the procedures for approach, landing and take-off which may be adopted according to the existence or absence of such aids:

and shall establish in relation to each runway which may be selected for use such aerodrome operating minima as are appropriate to each set of circumstances which can reasonably be expected.

(4) An aircraft to which Article 25 of this Order applies shall not commence a flight at a time when-

- (a) the cloud ceiling or the runway visual range at the aerodrome of departure is less than the relevant minimum specified for take-off; or
- (b) according to the information available to the commander of the aircraft it would not be able, without contravening paragraph (5) of this Article, to land at the aerodrome of intended destination at the estimated time of arrival there and at any alternate aerodrome at any time at which according to a reasonable estimate the aircraft would arrive there.

(5) An aircraft to which Article 25 of this Order applies when making a descent to an aerodrome shall not:-

- (a) descend below 1000 feet above the height of the aerodrome if the relevant runway visual range at the aerodrome is at the time less than the specified minimum for landing; or
- (b) (i) continue an approach to landing at any aerodrome by flying below the relevant specified decision height, or
- (ii) descend below the relevant specified minimum descent height

unless from that height the specified visual reference of landing is established and is maintained.

(6) If, according to the information available, an aircraft would as regards any flight be required by the Rules of the Air and Air Traffic Control to be flown in accordance with the Instrument Flight Rules at the aerodrome of intended landing, the commander of the aircraft shall select prior to take-off an alternate aerodrome unless no aerodrome suitable for that purpose is available.

(7) In this Article "specified" in relation to aerodrome operating minima means such particulars of aerodrome operating minima as have been specified by the operator in, or are ascertainable by reference to, the operations manual relating to that aircraft, or furnished in writing to the commander of the aircraft by the operator pursuant to the proviso to paragraph (1)(a) of this Article.

| | | | | |
|----------|----|---|------------|------------|
| Section: | 31 | Aircraft not registered in Hong Kong- aerodrome operating minima | 36 of 1999 | 01/07/1997 |
|----------|----|---|------------|------------|

Remarks:

Adaptation amendments retroactively made - see 36 of 1999 s. 3

(1) A public transport aircraft registered in a country other than Hong Kong shall not fly in or over Hong Kong unless the operator thereof shall have furnished to the Chief Executive such particulars as he may from time to time have required relating to the aerodrome operating minima specified by the operator in relation to aerodromes in Hong Kong for the purpose of limiting their use by the aircraft for take-off or landing, including any instructions given by the operator in relation to such aerodrome operating minima. The aircraft shall not fly in or over Hong Kong unless the operator shall have made such amendments or additions to the aerodrome operating minima so specified and any instructions so given as the Chief Executive may require for the purpose of ensuring the safety of the aircraft or the safety, efficiency or regularity of air navigation. (36 of 1999 s. 3)

(2) The aircraft shall not take off or land at an aerodrome in Hong Kong in contravention of the specified aerodrome operating minima or the specified instruction.

(3) Without prejudice to the provisions of paragraph (2) of this Article, a public transport aircraft registered in a country other than Hong Kong when making a descent to an aerodrome shall not:-

- (a) descend below 1000 feet above the height of the aerodrome if the relevant runway visual range at the aerodrome is at the time less than the specified minimum for landing; or
- (b) (i) continue an approach to landing at any aerodrome by flying below the relevant specified decision height, or
(ii) descend below the relevant specified minimum descent height

unless from that height the specified visual reference for landing is established and is maintained.

(4) In this Article "specified" in relation to an aircraft means specified by the operator in, or ascertainable by reference to, the particulars furnished by the operator to the Chief Executive pursuant to paragraph (1) of this Article. (36 of 1999 s. 3)

| | | | | |
|----------|----|--|--|------------|
| Section: | 32 | Pre-flight action by commander of aircraft | | 30/06/1997 |
|----------|----|--|--|------------|

The commander of an aircraft registered in Hong Kong shall satisfy himself before the aircraft takes off-

- (a) that the flight can safely be made, taking into account the latest information available as to the route and aerodromes to be used, the weather reports and forecasts available, and any alternative course of action which can be adopted in case the flight cannot be completed as planned;
- (b) that the equipment (including radio apparatus) required by or under this Order to be carried in the circumstances of the intended flight is carried and is in a fit condition for use;
- (c) that the aircraft is in every way fit for the intended flight, and that where a certificate of maintenance review is required by Article 9(1) of this Order to be in force, it is in force and will not cease to be in force during the intended flight;
- (d) that the load carried by the aircraft is of such weight, and is so distributed and secured that it may safely be carried on the intended flight;
- (e) in the case of a flying machine or airship, that sufficient fuel, oil and engine coolant (if required) are carried for the intended flight and that a safe margin has

been allowed for contingencies and, in the case of a flight for the purpose of public transport, that the instructions in the operations manual relating to fuel, oil and engine coolant have been complied with;

- (f) in the case of an airship or balloon, that sufficient ballast is carried for the intended flight;
- (g) in the case of a flying machine, that, having regard to the performance of the flying machine in the conditions to be expected on the intended flight, and to any obstructions at the places of departure and intended destination and on the intended route, it is capable of safely taking off, reaching and maintaining a safe height thereafter, and making a safe landing at the place of intended destination;
- (h) that any pre-flight check system established by the operator and set forth in the operations manual or elsewhere has been complied with by each member of the crew of the aircraft.

| | | | | |
|----------|----|------------------------------|--|------------|
| Section: | 33 | Pilots to remain at controls | | 30/06/1997 |
|----------|----|------------------------------|--|------------|

(1) The commander of an aircraft registered in Hong Kong, being a flying machine or glider, shall cause one pilot to remain at the controls at all times while the aircraft is in flight. If the aircraft is required by or under this Order to carry two pilots, the commander shall cause both pilots to remain at the controls during take-off and landing. If the aircraft carries two or more pilots (whether or not it is required to do so) and is engaged on a flight for the purpose of the public transport of passengers the commander shall remain at the controls during take-off and landing.

(2) Each pilot at the controls shall be secured in his seat by either a safety belt with or without one diagonal shoulder strap, or a safety harness except that during take-off and landing a safety harness shall be worn if it is required by Article 13 of this Order to be provided.

| | | | | |
|----------|----|--|------------|------------|
| Section: | 34 | Public transport of passengers-duties of commander | 36 of 1999 | 01/07/1997 |
|----------|----|--|------------|------------|

Remarks:

Adaptation amendments retroactively made - see 36 of 1999 s. 3

(1) This Article applies to flights for the purpose of the public transport of passengers by aircraft registered in Hong Kong.

(2) In relation to every flight to which this Article applies the commander of the aircraft shall-

- (a) before the aircraft takes off, take all reasonable steps to ensure that all passengers are made familiar with the position and method of use of emergency exits, safety belts, safety harnesses, and (where required to be carried) oxygen equipment, life jackets and the floor path lighting system and all other devices required by or under this Order and intended for use by passengers individually in case of an emergency occurring to the aircraft;
- (b) (i) if the aircraft is not a seaplane but is intended in the course of the flight to reach a point more than 30 minutes flying time (while flying in still air at the speed specified in the relevant certificate of airworthiness as the speed for compliance with regulations governing flights over water) from the nearest land, take all reasonable steps to ensure that before take-off, all passengers are given a demonstration of the method of use of the lifejackets required by or under this Order for the use of passengers.
- (ii) if the aircraft is not a seaplane but is required by Article 18(7) of this Order

to carry cabin attendants, take all reasonable steps to ensure that, before the aircraft takes-off on a flight:

- (aa) which is intended to proceed beyond gliding distance from land, or
- (bb) on which in the event of any emergency occurring during the take-off or during the landing at the intended destination or any likely alternate destination it is reasonably possible that the aircraft would be forced to land onto water;

all passengers are given a demonstration of the method of use of the lifejackets required by or under this Order for the use of passengers:

Provided that where the only requirements to give such a demonstration arises because it is reasonably possible that the aircraft would be forced to land onto water at one or more of the likely alternate destinations the demonstration need not be given until after the decision has been taken to divert to such a destination.

- (c) if the aircraft is a seaplane, take all reasonable steps to ensure that before the aircraft takes off all passengers are given a demonstration of the method of use of the equipment referred to in the preceding sub-paragraph;
- (d) before the aircraft takes off, and before it lands, take all reasonable steps to ensure that the crew of the aircraft are properly secured in their seats and that any persons carried in compliance with Article 18(7) of this Order are properly secured in seats which shall be in a passenger compartment and which shall be so situated that those persons can readily assist passengers;
- (e) before the aircraft takes-off, and before it lands, and whenever by reason of turbulent air or any emergency occurring during the flight he considers the precaution necessary:
 - (i) take all reasonable steps to ensure that all passengers of two years of age or more are properly secured in their seats by safety belts or safety harnesses and that all passengers under the age of two years are properly secured by means of a child restraint device; and
 - (ii) take all reasonable steps to ensure that those items of baggage in the passenger compartment which he reasonably considers ought by virtue of their size, weight or nature to be properly secured are properly secured and, in the case of an aircraft capable of seating more than 30 passengers, that such baggage is either stowed in the passenger compartment stowage spaces approved by the Chief Executive for the purpose of stowing baggage or carried in accordance with the terms of a written permission granted by the Chief Executive which permission may be granted subject to such conditions as the Chief Executive thinks fit. (36 of 1999 s. 3)
- (f) in an emergency, take all reasonable steps to ensure that all passengers are instructed in the emergency action which they should take;
- (g) in the case of aircraft in respect of which a certificate of airworthiness was first issued (whether in Hong Kong or elsewhere) on or after 1st January 1989 except in a case where a pressure greater than 700 millibars is maintained in all passenger and crew compartments throughout the flight, take all reasonable steps to ensure that-
 - (i) before the aircraft reaches flight level 100 the method of use of the oxygen provided in the aircraft in compliance with the requirements of Article 13 of this Order is demonstrated to all passengers;
 - (ii) when flying above flight level 120 all passengers and cabin attendants are recommended to use oxygen; and
 - (iii) during any period when the aircraft is flying above flight level 100 oxygen is used by all the flight crew of the aircraft;
- (h) in the case of aircraft in respect of which a certificate of airworthiness was first issued (whether in Hong Kong or elsewhere) prior to 1st January 1991, except in the case where a pressure greater than 700 millibars is maintained in all passenger

and crew compartments throughout the flight, take all reasonable steps to ensure that-

- (i) before the aircraft reaches flight level 130 the method of use of the oxygen provided in the aircraft in compliance with the requirements of Article 13 of this Order is demonstrated to all passengers;
- (ii) when flying above flight level 130 all passengers and cabin attendants are recommended to use oxygen; and
- (iii) during any period when the aircraft is flying above level 100 oxygen is used by all the flight crew of the aircraft;

Provided that he need not comply with the provisions of this sub-paragraph (h) if he complies instead with the provisions of sub-paragraph (g) of this Article.

| | | | | |
|----------|----|--------------------------------|------------|------------|
| Section: | 35 | Operation of radio in aircraft | 36 of 2000 | 16/06/2000 |
|----------|----|--------------------------------|------------|------------|

(1) The radio station in an aircraft shall not be operated, whether or not the aircraft is in flight, except in accordance with the conditions of the licence issued in respect of that station under the law of the country in which the aircraft is registered, and by a person duly licensed or otherwise permitted to operate the radio station under that law.

(2) Whenever an aircraft is in flight in such circumstances that it is required by or under this Order to be equipped with radio communications apparatus, a continuous radio watch shall be maintained by a member of the flight crew listening to the signals transmitted upon the frequency notified, or designated by a message received from an appropriate aeronautical radio station, for use by the aircraft:

Provided that-

- (a) the radio watch may be discontinued or continued on another frequency to the extent that a message as aforesaid so permits; and
- (b) the watch may be kept by a device installed in the aircraft if-
 - (i) the appropriate aeronautical radio station has been informed to that effect and has raised no objection; and
 - (ii) that station is notified, or in the case of a station situated in a country other than Hong Kong, otherwise designated as transmitting a signal suitable for that purpose.

(3) Whenever an aircraft is in flight in such circumstances that it is required by or under this Order to be equipped with radio or radio navigation equipment a member of the flight crew shall operate that equipment in such a manner as he may be instructed by the appropriate air traffic control unit or as may be notified in relation to any notified airspace in which the aircraft is flying.

(4) The radio station in an aircraft shall not be operated so as to cause interference which impairs the efficiency of aeronautical telecommunications or navigational services, and in particular emissions shall not be made except as follows:

- (a) emissions of the class and frequency for the time being in use, in accordance with general international aeronautical practice, in the airspace in which the aircraft is flying.
- (b) distress, urgency and safety messages and signals, in accordance with general international aeronautical practice;
- (c) messages and signals relating to the flight of the aircraft, in accordance with general international aeronautical practice;
- (d) such public correspondence messages as may be permitted by or under the aircraft radio station licence referred to in paragraph (1) of this Article.

(5) In every aircraft registered in Hong Kong which is equipped with radio communication apparatus a telecommunications log book shall be kept in which the following entries shall be made: (36 of 2000 s. 28)

- (a) the identification of the aircraft radio station;
- (b) the date and time of the beginning and end of every radio watch maintained in the

- aircraft and of the frequency on which it was maintained;
- (c) the date and time, and particulars of all messages and signals sent or received, including in particular details of any distress signals or distress messages sent or received;
 - (d) particulars of any action taken upon the receipt of a distress signal or distress message;
 - (e) particulars of any failure or interruption of radio communications and the cause thereof;

Provided that a telecommunications log book shall not be required to be kept in respect of communication by radiotelephony with a radio station on land or on a ship which provides a radio service for aircraft. (36 of 2000 s. 28)

(6) The flight radio operator maintaining radio watch shall sign the entries in the telecommunications log book indicating the times at which he began and ended the maintenance of such watch. (36 of 2000 s. 28)

(7) The telecommunications log book shall be preserved by the operator of the aircraft until a date 6 months after the date of the last entry therein. (36 of 2000 s. 28)

(8) In any flying machine registered in Hong Kong which is engaged on a flight for the purpose of public transport the pilot and the flight engineer (if any) shall not make use of a hand-held microphone (whether for the purpose of radio communication or of intercommunication within the aircraft) whilst the aircraft is flying in controlled airspace below flight level 150 or is taking off or landing.

| | | | | |
|----------|----|--------------------------------|------------|------------|
| Section: | 36 | Minimum navigation performance | 36 of 1999 | 01/07/1997 |
|----------|----|--------------------------------|------------|------------|

Remarks:

Adaptation amendments retroactively made - see 36 of 1999 s. 3

An aircraft registered in Hong Kong shall not fly in airspace prescribed for the purpose of this Article by Regulation 17 of Schedule 15 of this Order unless-

- (a) it is equipped with navigation systems which enable the aircraft to maintain the prescribed navigation performance capability; and
- (b) the navigation systems required by paragraph (a) hereof are approved by the Chief Executive and installed and maintained in a manner approved by the Chief Executive, and
- (c) the operating procedures for the navigation systems required by paragraph (a) hereof are approved by the Chief Executive; and
- (d) the equipment is operated in accordance with the approved procedures while the aircraft is flying in the said airspace.

(36 of 1999 s. 3)

| | | | | |
|----------|----|---|------------|------------|
| Section: | 37 | Use of flight recording systems and preservation of records | 36 of 1999 | 01/07/1997 |
|----------|----|---|------------|------------|

Remarks:

Adaptation amendments retroactively made - see 36 of 1999 s. 3

(1) On any flight on which a flight data recorder or a cockpit voice recorder or a combined cockpit voice recorder/flight data recorder is required by sub-paragraph 4(4), (5), (6) or (7) of Schedule 5 to this Order to be carried in an aeroplane, it shall always be in use from the beginning of the take-off run to the end of the landing run.

(2) The operator of the aeroplane shall at all times, subject to the provisions of Article 61 of this Order, preserve:

- (a) the last 25 hours of recording made by any flight data recorder required by or under this Order to be carried in an aeroplane; and
- (b) a record of not less than one representative flight, that is to say, a recording of a flight made within the last 12 months which includes a take-off, climb, cruise, descent, approach to landing and landing, together with a means of identifying the record with the flight to which it relates;

and shall preserve such records for such period as the Chief Executive may in a particular case direct.

(3) On any flight on which a cockpit voice recorder or a flight data recorder or a combined cockpit voice recorder/flight data recorder is required by paragraph 4(14) of Schedule 5 of this Order to be carried in a helicopter, it shall always be in use from the time the rotors first turn for the purpose of taking off until the rotors are next stopped.

(4) The operator of the helicopter shall at all times, subject to Article 61 of this Order, preserve:

- (a) the last 8 hours of recording made by any flight data recorder specified at sub-paragraph (i) or (ii) of Scale SS of paragraph 5 of Schedule 5 to this Order and required by or under this Order to be carried in the helicopter;
- (b) in the case of a combined cockpit voice recorder/flight data recorder specified at sub-paragraph (iii) of the said Scale SS and required by or under this Order to be carried in a helicopter either:
 - (i) the last eight hours of recording; or
 - (ii) the last five hours of recording or the duration of the last flight, whichever is the greater (together hereinafter referred to in this Article as the "required recording"), together with an additional period of recording for either:
 - (aa) the period immediately preceding the required recording; or
 - (bb) such period or periods as the Chief Executive may permit in any particular case or class of cases generally.

(5) The additional recording retained pursuant to sub-paragraphs (b)(ii)(aa) and (bb) of paragraph (4) above shall, together with the required recording, total a period of eight hours and shall be retained in accordance with arrangements approved by the Chief Executive.

(6) An approval granted by the Chief Executive for the purposes of this Article shall be in writing and may be subject to such conditions as the Chief Executive thinks fit.

(36 of 1999 s. 3)

| | | | |
|----------|----|-------------------|------------|
| Section: | 38 | Towing of gliders | 30/06/1997 |
|----------|----|-------------------|------------|

(1) An aircraft in flight shall not tow a glider unless the certificate of airworthiness issued or rendered valid in respect of the towing aircraft under the law of the country in which that aircraft is registered includes an express provision that it may be used for that purpose.

(2) The length of the combination of towing aircraft, tow rope and glider in flight shall not exceed 150 metres.

(3) The commander of an aircraft which is about to tow a glider shall satisfy himself, before the towing aircraft takes off-

- (a) that the tow rope is in good condition and is of adequate strength for the purpose, and that the combination of towing aircraft and glider, having regard to its performance in the conditions to be expected on the intended flight and to any obstructions at the place of departure and on the intended route, is capable of safely taking off, reaching and maintaining a safe height at which to separate the combination and that thereafter the towing aircraft can make a safe landing at the place of intended destination;
- (b) that signals have been agreed and communication established with persons suitably stationed so as to enable the glider to take off safely;
- (c) that emergency signals have been agreed between the commander of the towing

aircraft and the commander of the glider, to be used, respectively, by the commander of the towing aircraft to indicate that the tow should immediately be released by the glider, and by the commander of the glider to indicate that the tow cannot be released.

(4) The glider shall be attached to the towing aircraft by means of the tow rope before the aircraft takes off.

| | | | | |
|----------|----|--|--|------------|
| Section: | 39 | Towing, picking up and raising of persons and articles | | 30/06/1997 |
|----------|----|--|--|------------|

(1) Subject to the provisions of this Article, an aircraft in flight shall not, by means external to the aircraft, tow any article, other than a glider, or pick up or raise any person, animal or article, unless the certificate of airworthiness issued or rendered valid in respect of that aircraft under the law of the country in which the aircraft is registered includes an express provision that it may be used for that purpose.

(2) An aircraft shall not launch or pick up tow ropes, banners or similar articles other than at an aerodrome.

(3) An aircraft in flight shall not tow any article, other than a glider, at night or when flight visibility is less than one nautical mile.

(4) The length of the combination of towing aircraft, tow rope, and article in tow, shall not exceed 150 metres.

(5) A helicopter shall not fly at any height over a congested area of a city, town or settlement at any time when any person, article or animal is suspended from the helicopter.

(6) A passenger shall not be carried in a helicopter at any time when an article, person or animal is suspended therefrom, other than a passenger who has duties to perform in connection with the article, person or animal or a passenger who has been picked up or raised by means external to the helicopter or a passenger who it is intended shall be lowered to the surface by such means.

(7) Nothing in this Article shall-

- (a) prohibit the towing in a reasonable manner by an aircraft in flight of any radio aerial, any instrument which is being used for experimental purposes, or any signal, apparatus or article required or permitted by or under this Order to be towed or displayed by an aircraft in flight;
- (b) prohibit the picking up or raising of any person, animal or article in an emergency or for the purpose of saving life;
- (c) apply to any aircraft while it is flying in accordance with the "B Conditions" set forth in Schedule 2 to this Order;
- (d) be taken to permit the towing or picking up of a glider otherwise than in accordance with Article 38 of this Order.

| | | | | |
|----------|----|----------------------------------|------------|------------|
| Section: | 40 | Dropping of animals and articles | 36 of 1999 | 01/07/1997 |
|----------|----|----------------------------------|------------|------------|

Remarks:

Adaptation amendments retroactively made - see 36 of 1999 s. 3

(1) Articles and animals (whether or not attached to a parachute) shall not be dropped, or permitted to drop, from an aircraft in flight so as to endanger persons or property.

(2) Except under and in accordance with the terms of an aerial application certificate granted under Article 42 of this Order articles and animals (whether or not attached to a parachute) shall not be dropped or permitted to drop, to the surface from an aircraft flying over Hong Kong:

Provided that this paragraph shall not apply to the dropping of articles by, or with the

authority of, the commander of the aircraft in any of the following circumstances:

- (a) the dropping of articles for the purpose of saving life;
- (b) the jettisoning, in case of emergency, of fuel or other articles in the aircraft;
- (c) the dropping of ballast in the form of fine sand or water;
- (d) the dropping of articles solely for the purpose of navigating the aircraft in accordance with ordinary practice or with the provisions of this Order;
- (e) the dropping at an aerodrome of tow ropes, banners, or similar articles towed by aircraft;
- (f) the dropping of articles for the purposes of public health or as a measure against weather conditions, surface icing or oil pollution, or for training for the dropping of articles for any such purposes, if the articles are dropped with the permission of the Chief Executive and in accordance with any conditions subject to which that permission may have been given; (36 of 1999 s. 3)
- (g) the dropping of wind drift indicators for the purpose of enabling parachute descents to be made if the wind drift indicators are dropped with the permission of the Chief Executive and in accordance with any conditions subject to which that permission may have been given. (36 of 1999 s. 3)

(3) For the purposes of this Article dropping includes projecting and lowering.

(4) Nothing in this Article shall prohibit the lowering of any animal or article from a helicopter to the surface, if the certificate of airworthiness issued or rendered valid in respect of the helicopter under the law of the country in which it is registered includes an express provision that it may be used for that purpose.

| | | | | |
|----------|----|---------------------|------------|------------|
| Section: | 41 | Dropping of persons | 36 of 1999 | 01/07/1997 |
|----------|----|---------------------|------------|------------|

Remarks:

Adaptation amendments retroactively made - see 36 of 1999 s. 3

(1) A person shall not drop, be dropped or permitted to drop to the surface or jump from an aircraft flying over Hong Kong except under and in accordance with the terms of a written permission granted by the Chief Executive under this Article. (36 of 1999 s. 3)

(2) For the purpose of this Article dropping includes projecting and lowering.

(3) Notwithstanding the grant of a permission under paragraph (1) of this Article, a person shall not drop, be dropped or be permitted to drop from an aircraft in flight so as to endanger persons or property.

(4) An aircraft shall not be used for the purpose of dropping persons unless the certificate of airworthiness issued or rendered valid in respect of that aircraft under the law of the country in which the aircraft is registered includes an express provision that it may be used for that purpose and the aircraft is operated in accordance with the written permission granted by the Chief Executive under this Article. (36 of 1999 s. 3)

(5) Every applicant for and every holder of a permission shall make available to the Chief Executive if requested to do so a parachuting manual and shall make such amendments or additions to such manual as the Chief Executive may require. The holder of a permission shall make available to every employee or person who is engaged or may engage in parachuting activities conducted by him the manual which shall contain all such information and instructions as may be necessary to enable such employees or persons to perform their duties. (36 of 1999 s. 3)

(6) Nothing in this Article shall apply to the descent of persons by parachute from an aircraft in an emergency.

(7) Nothing in this Article shall prohibit the lowering of any person in an emergency or for the purpose of saving life.

(8) Nothing in this Article shall prohibit the lowering of any person from a helicopter to the surface, if the certificate of airworthiness issued or rendered valid in respect of the helicopter under the law of the country in which it is registered includes an express provision that it may be

used for that purpose.

| | | | | |
|----------|----|---|------------|------------|
| Section: | 43 | Carriage of weapons and of munitions of war | 36 of 1999 | 01/07/1997 |
|----------|----|---|------------|------------|

Remarks:

Adaptation amendments retroactively made - see 36 of 1999 s. 3

- (1) An aircraft shall not carry any munition of war unless:
 - (a) such munition of war is carried with the written permission of the Chief Executive and in accordance with any conditions relating thereto; and
 - (b) the commander of the aircraft is informed in writing by the operator before the flight commences of the type, weight or quantity and location of any such munition of war on board or suspended beneath the aircraft and any conditions of the permission of the Chief Executive. (36 of 1999 s. 3)
- (2) Notwithstanding paragraph (1) of this Article it shall be unlawful for an aircraft to carry any weapon or munition of war in any compartment or apparatus to which passengers have access.
- (3) It shall be unlawful for a person to carry or have in his possession or take or cause to be taken on board an aircraft, to suspend or cause to be suspended beneath an aircraft or to deliver or cause to be delivered for carriage thereon any weapon or munition of war unless-
 - (a) the weapon or munition of war:
 - (i) is either part of the baggage of a passenger on the aircraft or consigned as cargo to be carried thereby;
 - (ii) is carried in a part of the aircraft, or in any apparatus attached to the aircraft inaccessible to passengers; and
 - (iii) in case of a firearm, is unloaded;
 - (b) particulars of the weapon or munition of war have been furnished by that passenger or by the consignor to the operator before the flight commences; and
 - (c) without prejudice to paragraph (1) of this Article the operator consents to the carriage of such weapon or munition of war by the aircraft.
- (4) Nothing in this Article shall apply to any weapon or munition of war taken or carried on board an aircraft registered in a country other than Hong Kong, if the weapon or munition of war, as the case may be, may under the law of the country in which the aircraft is registered be lawfully taken or carried on board for the purpose of ensuring the safety of the aircraft or of persons on board.
- (5) For the purposes of this Article a "munition of war" means any weapon, ammunition or article containing an explosive or any noxious liquid, gas or other thing which is designed or made for use in warfare or against persons, including parts, whether components or accessories, for such weapon, ammunition or article.

| | | | | |
|----------|----|-----------------------------|-----------------|------------|
| Section: | 46 | Exits and break-in markings | L.N. 72 of 2000 | 01/09/2000 |
|----------|----|-----------------------------|-----------------|------------|

- (1) This Article shall apply to every public transport aircraft registered in Hong Kong.
- (2) Whenever an aircraft to which this Article applies is carrying passengers, every exit therefrom and every internal door in the aircraft shall be in working order, and during take-off and landing and during any emergency, every such exit and door shall be kept free of obstruction and shall not be fastened by locking or otherwise so as to prevent, hinder or delay its use by passengers:
Provided that-
 - (a) an exit may be obstructed by cargo if it is an exit which, in accordance with arrangements approved by the Chief Executive either generally or in relation to a class of aircraft or a particular aircraft, is not required for use by passengers; (36

of 1999 s. 3)

- (b) a door between the flight crew compartment and any adjacent compartment to which passengers have access may be locked or bolted if the commander of the aircraft so determines, for the purpose of preventing access by passengers to the flight crew compartment; and
 - (c) nothing in this paragraph shall apply to any internal door which is so placed that it cannot prevent, hinder or delay the exit of passengers from the aircraft in an emergency if it is not in working order.
- (3) Every exit from the aircraft shall be marked with the words "Exit" or "Emergency Exit" in English in capital letters and "出口" or "緊急出口" (as the case may be) in Chinese. (36 of 1999 s. 3)
- (4) (a) Every exit from the aircraft shall be marked with instructions in English and Chinese and with diagrams, to indicate the correct method of opening the exit; (36 of 1999 s. 3)
 - (b) The markings shall be placed on or near the inside surface of the door or other closure of the exit and, if it is openable from the outside of the aircraft, on or near the exterior surface.
- (5) (a) Every aircraft to which this Article applies, being an aircraft of which the maximum total weight authorized exceeds 3600 kg, shall be marked upon the exterior surface of its fuselage with markings to show the areas (in this paragraph referred to as "break-in areas") which can, for purposes of rescue in an emergency, be most readily and effectively broken into by persons outside the aircraft.
- (b) The break-in areas shall be rectangular in shape and shall be marked by right-angled corner markings, each arm of which shall be 10 centimetres in length along its outer edge and 2.5 centimetres in width.
 - (c) The words "Cut Here in Emergency" in English in capital letters and "緊急切破處" in Chinese shall be marked across the centre of each break-in area: (36 of 1999 s. 3)

Provided that this paragraph shall not apply to helicopters.

(6) On every flight by an aircraft to which this Article applies, being an aircraft of which the maximum total weight authorised exceeds 5700 kg, every exit from such an aircraft intended to be used by passengers in an emergency shall be marked upon the exterior of the aircraft by a band not less than 5 centimetres in width outlining the exit.

(7) The markings required by this Article shall-

- (a) be painted, or affixed by other equally permanent means;
- (b) except in the case of the markings required by paragraph (6) of this Article, be red in colour, and in any case in which the colour of the adjacent background is such as to render red markings not readily visible, be outlined in white or some other contrasting colour in such a manner as to render them readily visible;
- (c) in the case of the markings required by paragraph (6) of this Article, be of a colour clearly contrasting with the background on which it appears; and
- (d) be kept at all times clean and unobscured.

(8) If one, but not more than one, exit from an aircraft becomes inoperative at a place where it is not reasonably practicable for it to be repaired or replaced, nothing in this Article shall prevent that aircraft from carrying passengers until it next lands at a place where the exit can be repaired or replaced:

Provided that-

- (a) the number of passengers carried and the position of the seats which they occupy is in accordance with arrangements approved by the Chief Executive either in relation to the particular aircraft or to a class of aircraft; and (36 of 1999 s. 3)
- (b) in accordance with arrangements so approved, the exit is fastened by locking or otherwise, the words "Exit" and "出口" or "Emergency Exit" and "緊急出口" are covered, and the exit is marked by a red disc at least 23 centimetres in diameter with a horizontal white bar across it bearing the words "No exit" in red letters and "

非供出口用" in red characters. (36 of 1999 s. 3)

| | | | |
|----------|----|--------------------------------|------------|
| Section: | 47 | Imperilling safety of aircraft | 30/06/1997 |
|----------|----|--------------------------------|------------|

A person shall not recklessly or negligently act in a manner likely to endanger an aircraft, or any person therein.

| | | | |
|----------|----|--|------------|
| Section: | 48 | Imperilling safety of any person or property | 30/06/1997 |
|----------|----|--|------------|

A person shall not recklessly or negligently cause or permit an aircraft to endanger any person or property.

| | | | |
|----------|----|-------------------------|------------|
| Section: | 49 | Drunkenness in aircraft | 30/06/1997 |
|----------|----|-------------------------|------------|

- (1) A person shall not enter any aircraft when drunk, or be drunk in any aircraft.
- (2) A person shall not, when acting as a member of the crew of any aircraft or being carried in any aircraft for the purpose of so acting, be under the influence of drink or a drug to such an extent as to impair his capacity so to act.

| | | | |
|----------|----|---------------------|------------|
| Section: | 50 | Smoking in aircraft | 30/06/1997 |
|----------|----|---------------------|------------|

- (1) Notices indicating when smoking is prohibited shall be exhibited in every aircraft registered in Hong Kong so as to be visible from each passenger seat therein.
- (2) A person shall not smoke in any compartment of an aircraft registered in Hong Kong at a time when smoking is prohibited in that compartment by a notice to that effect exhibited by or on behalf of the commander of the aircraft.

| | | | |
|----------|----|------------------------------------|------------|
| Section: | 51 | Authority of commander of aircraft | 30/06/1997 |
|----------|----|------------------------------------|------------|

Every person in an aircraft registered in Hong Kong shall obey all lawful commands which the commander of that aircraft may give for the purpose of securing the safety of the aircraft and of persons or property carried therein, or the safety, efficiency or regularity of air navigation.

| | | | |
|----------|----|-----------|------------|
| Section: | 52 | Stowaways | 30/06/1997 |
|----------|----|-----------|------------|

A person shall not secrete himself for the purpose of being carried in an aircraft without the consent of either the operator or the commander thereof or of any other person entitled to give consent to his being carried in the aircraft.

| | | | |
|----------|----|--|------------|
| Section: | 55 | Fatigue of crew-responsibilities of crew | 30/06/1997 |
|----------|----|--|------------|

(1) A person shall not act as a member of the crew of an aircraft to which this Article applies if he knows or suspects that he is suffering from, or, having regard to the circumstances of the flight to be undertaken, is likely to suffer from, such fatigue as may endanger the safety of the aircraft or of its occupants.

(2) A person shall not act as a member of the flight crew of an aircraft to which this Article applies unless he has ensured that the operator of the aircraft is aware of his flight times during the period of 28 days preceding the flight.

| | | | |
|----------|----|--------------------|------------|
| Section: | 58 | Records to be kept | 30/06/1997 |
|----------|----|--------------------|------------|

The operator of a public transport aircraft registered in Hong Kong shall, in respect of any flight by that aircraft during which it may fly at an altitude of more than 49000 feet, keep a record in a manner prescribed of the total dose of cosmic radiation to which the aircraft is exposed during the flight together with the names of the members of the crew of the aircraft during the flight.

| | | | |
|----------|----|-------------------------------------|------------|
| Section: | 59 | Production of documents and records | 30/06/1997 |
|----------|----|-------------------------------------|------------|

(1) The commander of an aircraft shall, within a reasonable time after being requested to do so by an authorized person, cause to be produced to that person-

- (a) the certificates of registration and airworthiness in force in respect of the aircraft;
- (b) the licences of its flight crew;
- (c) such other documents as the aircraft is required by Article 57 of this Order to carry when in flight.

(2) The operator of an aircraft registered in Hong Kong shall, within a reasonable time after being requested to do so by an authorized person, cause to be produced to that person such of the following documents or records as may have been requested by that person being documents or records which are required, by or under this Order, to be in force or to be carried, preserved or made available:

- (a) the documents referred to in Schedule 12 to this Order as Documents A, B and G;
- (b) the aircraft log book, engine log books and variable pitch propeller log books required under this Order to be kept;
- (c) the weight schedule, if any, required to be preserved under Article 16 of this Order;
- (d) in the case of a public transport aircraft or aerial work aircraft, the documents referred to in Schedule 12 to this Order as Documents D, E, F and H;
- (e) any records of flight times, duty periods and rest periods which he is required by Article 54(4) of this Order to preserve, and such other documents and information in the possession or control of the operator, as the authorized person may require for the purpose of determining whether those records are complete and accurate;
- (f) any such operations manuals as are required to be made available under Article 25(2)(a)(i) of this Order;
- (g) the record made by any flight data recorder required to be carried by or under this Order;
- (h) the record made from any cosmic radiation detection equipment together with the record of the names of the members of the crew of the aircraft which are required to be kept under Article 58 of this Order.

(3) (a) The holder of a licence granted or rendered valid under this Order shall, within a reasonable time after being requested to do so by an authorized person, cause to be produced to that person his licence, including any certificate of validation. The

requirements of this paragraph shall be deemed to have been complied with, except in relation to licences required by Article 57 of this Order to be carried in the aircraft or kept at an aerodrome, if the licence requested is produced within five days after the request has been made at a police station in Hong Kong specified, at the time of the request, by the person to whom the request is made.

- (b) The foregoing provisions of this paragraph shall apply to a medical certificate issued pursuant to Article 19(1)(b)(ii) as they apply to a licence granted or rendered valid under this Order.

(4) Every person required by Article 22 of this Order to keep a personal flying log book shall cause it to be produced within a reasonable time to an authorized person after being requested to do so by him within two years after the date of the last entry therein.

| | | | | |
|----------|----|---------------------------------|--|------------|
| Section: | 61 | Preservation of documents, etc. | | 30/06/1997 |
|----------|----|---------------------------------|--|------------|

A person required by this Order to preserve any document or record by reason of his being the operator of an aircraft shall, if he ceases to be the operator of the aircraft, continue to preserve the document or record as if he had not ceased to be the operator, and in the event of his death the duty to preserve the document or record shall fall upon his personal representative:

Provided that if-

- (a) another person becomes the operator of the aircraft he or his personal representative shall deliver to that person upon demand the certificates of maintenance review and release to service, the log books and the weight schedule and any record made by a flight data recorder and preserved in accordance with Article 37(2) of this Order which are in force or required to be preserved in respect of that aircraft;
- (b) an engine or variable pitch propeller is removed from the aircraft and installed in another aircraft operated by another person he or his personal representative shall deliver to that person upon demand the log book relating to that engine or propeller; or
- (c) any person in respect of whom a record has been kept by him in accordance with Article 54(4) of this Order becomes a member of the flight crew of a public transport aircraft registered in Hong Kong and operated by another person he or his personal representative shall deliver those records to that other person upon demand,

and it shall be the duty of that other person to deal with the document or record delivered to him as if he were the first-mentioned operator.

| | | | | |
|----------|----|--|------------|------------|
| Section: | 62 | Revocation, suspension and variation of certificates, licences and other documents | 36 of 1999 | 01/07/1997 |
|----------|----|--|------------|------------|

Remarks:

Adaptation amendments retroactively made - see 36 of 1999 s. 3

(1) Subject to paragraph (4) of this Article, the Chief Executive may, if he thinks fit, provisionally suspend or vary any certificate, licence, approval, permission, exemption, authorization or other document issued, granted or having effect under this Order, pending inquiry into or consideration of the case. The Chief Executive may, on sufficient ground being shown to his satisfaction after due inquiry, revoke, suspend or vary any such certificate, licence approval, permission, exemption, authorisation or other document.

(2) The holder or any person having the possession or custody of any certificate, licence, approval, permission, exemption or other document which has been revoked, suspended or varied

under this Order shall surrender it to the Chief Executive within a reasonable time after being required to do so by him.

(3) The breach of any condition subject to which any certificate, licence, approval, permission, exemption or other document, other than a licence issued in respect of an aerodrome, has been granted or issued, or which has effect under this Order shall, in the absence of provision to the contrary in the document, render the document invalid during the continuance of the breach.

(4) Notwithstanding paragraph (1) of this Article, a flight manual, performance schedule or other document incorporated by reference in the certificate of airworthiness may be varied on sufficient ground being shown to the satisfaction of the Chief Executive, whether or not after due inquiry.

(36 of 1999 s. 3)

| | | | | |
|----------|----|------------------|------------|------------|
| Section: | 64 | Rules of the air | 36 of 1999 | 01/07/1997 |
|----------|----|------------------|------------|------------|

Remarks:

Adaptation amendments retroactively made - see 36 of 1999 s. 3

PART VIII

CONTROL OF AIR TRAFFIC

(1) The Chief Executive may make rules of the air supplementary to, but not inconsistent with, the Rules of the Air contained in Schedule 14 to this Order. (36 of 1999 s. 3)

(2) Subject to the provisions of paragraph (3) of this Article, it shall be an offence to contravene, to permit the contravention of, or to fail to comply with, the Rules of the Air contained in Schedule 14 to this Order.

(3) It shall be lawful for the Rules of the Air to be departed from to the extent necessary-

(a) for avoiding immediate danger; or

(b) for complying with the law of any country other than Hong Kong within which the aircraft then is; or

(c) for complying with Military Flying Regulations (Joint Service Publication 318) or Flying Orders to Contractors (Aviation Publication 67) issued by the Secretary of State in relation to an aircraft of which the commander is acting as such in the course of his duty as a member of Her Majesty's naval, military or air forces.

(4) If any departure from the Rules of the Air is made for the purpose of avoiding immediate danger, the commander of the aircraft shall cause written particulars of the departure, and of the circumstances giving rise to it, to be given within 10 days thereafter to the competent authority of the country in whose territory the departure was made or if the departure was made over the high seas, to the Chief Executive. (36 of 1999 s. 3)

(5) Nothing in the Rules of the Air shall exonerate any person from the consequences of any neglect in the use of lights or signals or of the neglect of any precautions required by ordinary aviation practice or by the special circumstances of the case.

| | | | | |
|----------|-----|-----------------------------------|------------|------------|
| Section: | 64A | Provision of air traffic services | 36 of 1999 | 01/07/1997 |
|----------|-----|-----------------------------------|------------|------------|

Remarks:

Adaptation amendments retroactively made - see 36 of 1999 s. 3

(1) No person shall provide an air traffic service otherwise than under and in accordance with the terms of an approval granted to him by the Chief Executive, and the Chief Executive shall grant an approval to any person applying therefor if he is satisfied that the person is competent, having regard to his organization, staffing, equipment, maintenance and other arrangements, to

provide a service which is safe for use by aircraft.

(2) The person in charge of an aerodrome (other than a Government aerodrome) in respect of which there is equipment for providing holding aid, let-down aid or approach aid by radio or radar shall:

- (a) inform the Chief Executive in advance of periods during and times at which any such equipment is to be in operation for the purpose of providing such aid as is specified by the said person; and
- (b) during any period and at such times as so notified, cause an air traffic control service to be provided for any aircraft which is flying in, or in the vicinity of, the aerodrome traffic zone whether or not it is flying by visual reference to the surface.

(3) The Chief Executive may direct that there shall be provided in respect of any aerodrome (other than a Government aerodrome) such air traffic control service, aerodrome flight information service or means of two-way radio communication as the Chief Executive considers appropriate in respect thereof. The Chief Executive may specify in his direction the periods during and the times at which such a service or such means shall be provided and the person in charge of the aerodrome shall cause such a service or such means to be provided in accordance with any such direction.

(4) Obligations to cause an air traffic control service to be provided arising under paragraphs (2) or (3) are without prejudice to each other.

(36 of 1999 s. 3)

| | | | | |
|----------|----|---|------------|------------|
| Section: | 65 | Licensing of air traffic controllers, student air traffic controllers and aerodrome flight information service officers | 36 of 1999 | 01/07/1997 |
|----------|----|---|------------|------------|

Remarks:

Adaptation amendments retroactively made - see 36 of 1999 s. 3

(1) The Chief Executive may grant a licence subject to such conditions as he thinks fit to any person to act as an air traffic controller, as a student air traffic controller or as an aerodrome flight information service officer upon his being satisfied that the applicant is a fit person to hold the licence and is qualified by reason of his knowledge, experience, competence, skill, physical and mental fitness so to act, and for that purpose the applicant shall furnish such evidence and undergo such examinations and tests (including in particular medical examinations) as the Chief Executive may require of him:

Provided that the Chief Executive shall not grant-

- (a) a student air traffic controller's licence or an aerodrome flight information service officer's licence to a person under the age of 18 years; or
- (b) an air traffic controller's licence which includes an Aerodrome Control Rating, an Approach Control Rating or an Area Control Rating, to a person under the age of 20 years; or
- (c) an air traffic controller's licence which includes any other rating, to a person under the age of 21 years.

(2) Every licence to act as an air traffic controller shall include (a) ratings of one or more of the classes set forth in Schedule 10 to this Order specifying the type of air traffic control service which the holder of the licence is competent to provide, (b) a list of the places at which, and (c) the type of radar equipment, if any, with the aid of which he may provide the service. If throughout any period of 90 days the holder of the licence has not at any time provided at a particular place the type of air traffic control service specified in the rating, the rating shall, without prejudice to the Chief Executive's powers under Article 62 of this Order, cease to be valid for that place at the end of that period, and upon a rating ceasing to be valid for a place the holder of the licence shall forthwith inform the Chief Executive to that effect and shall forward the licence to the Chief Executive to enable it to be endorsed accordingly.

(3) Every licence to act as a student air traffic controller shall be valid only for the purpose

of authorizing the holder to provide air traffic control service under the supervision of another person who is present at the time and is the holder of a valid air traffic controller's licence which includes a rating specifying the type of air traffic control service which is being provided by the student air traffic controller and valid at the place in question.

(4) Every licence to act as an aerodrome flight information service officer shall be valid only for the purpose of authorizing the holder to provide an aerodrome flight information service at an aerodrome specified in the licence. If throughout any period of 180 days, the holder of the licence has not at any time provided such a service at a particular aerodrome, the licence shall cease to be valid for that aerodrome at the end of that period.

(5) A licence to act as an air traffic controller, as a student air traffic controller or as an aerodrome flight information service officer shall not be valid unless the holder of the licence has signed his name thereon in ink with his ordinary signature.

(6) Subject to the provisions of Article 62 of this Order, a licence to act as an air traffic controller, as a student air traffic controller or as an aerodrome flight information service officer shall remain in force for the period indicated in the licence and may be renewed by the Chief Executive from time to time, upon his being satisfied that the applicant is a fit person and is qualified as aforesaid. If no period is indicated in the licence, it shall remain in force, subject as aforesaid, for the lifetime of the holder.

(7) Every applicant for and holder of an air traffic controller's licence or a student air traffic controller's licence shall upon such occasions as the Chief Executive may require-

- (a) submit himself to medical examination by a person approved by the Chief Executive either generally or in a particular case who shall make a report to the Chief Executive in such form as the Chief Executive may require; and
- (b) submit himself to such examinations and tests and furnish such evidence as to his knowledge, experience, competence and skill, as the Chief Executive may require, and such examinations and tests may be conducted by the Chief Executive or by a person approved by the Chief Executive.

(8) Every applicant for and holder of an aerodrome flight information service officer's licence shall, upon such occasions as the Chief Executive may require, subject himself to such examinations and tests and furnish such evidence as to his knowledge, experience, competence and skill as the Chief Executive may require, and such examinations and tests may be conducted by the Chief Executive or by a person approved by the Chief Executive.

(9) On the basis of the medical examination referred to in paragraph (7) of this Article, the Chief Executive or any person approved by him as competent to do so may issue a medical certificate subject to such conditions as he thinks fit to the effect that the holder of the licence has been assessed as fit to perform the functions to which the licence relates. The certificate shall, without prejudice to Article 68 of this Order, be valid for such period as is therein specified, and shall be deemed to form part of the licence.

(10) The holder of an air traffic controller's licence or student air traffic controller's licence shall not provide any type of air traffic control service at any such aerodrome or place as is referred to in Article 66(1) of this Order unless his licence includes a medical certificate issued and in force under paragraph (9) of this Article.

(36 of 1999 s. 3)

| | | | |
|----------|----|--|------------|
| Section: | 66 | Prohibition of unlicensed air traffic controllers, student air traffic controllers and aerodrome flight information service officers | 30/06/1997 |
|----------|----|--|------------|

(1) A person shall not provide at any place any type of air traffic control service or an aerodrome flight information service or hold himself out, whether by use of a radio call sign or in any other way, as a person who may provide any type of air traffic service or an aerodrome flight information service unless:

- (a) in the case of an air traffic control service, he is the holder, and complies with the

terms of:

- (i) a valid student air traffic controller's licence granted under this Order and he is supervised in accordance with Article 65(3) of this Order; or
 - (ii) a valid air traffic controller's licence so granted authorizing him to provide that type of service at that place; or
 - (iii) a valid air traffic controller's licence so granted which does not authorise him to provide that type of service at that place, but he is supervised by a person who is present at the time and who is the holder of a valid air traffic controller's licence so granted which authorises him to provide at that place the type of air traffic control service which is being provided; or
- (b) in the case of an aerodrome flight information service, he is the holder and complies with the terms of an aerodrome flight information service officer's licence granted under this Order authorising him to provide such a service at that place:

Provided that a licence shall not be required by any person who acts in the course of his duty as a member of any of Her Majesty's naval, military or air forces or a visiting force.

(2) The holder of an air traffic controller's licence shall not be entitled to perform any of the functions specified in Schedule 10 to this Order in respect of a rating at any place unless:

- (a) his licence includes that rating and the rating is valid for the place at which, and the type of radar equipment, if any, with the aid of which, the functions are performed; or
- (b) he is supervised by a person who is present at the time and who is the holder of a valid air traffic controller's licence granted under this Order which authorizes him to provide at that place the type of air traffic control service which is being provided.

(3) A person shall not provide any type of air traffic control service or an aerodrome flight information service unless he identifies himself in such a manner as may be notified.

(4) Nothing in a licence granted under Article 65 of this Order shall permit any person to operate manually any direction-finding equipment for the purpose of providing air traffic control service to an aircraft at a time when he is providing air traffic control service or making signals to that aircraft or to another aircraft.

(5) Nothing in this Article shall prohibit the holder of a valid air traffic controller's licence from providing at any place for which the licence includes a valid rating, information to aircraft in flight in the interests of safety.

| | | | | |
|----------|----|-----------------------------------|------------|------------|
| Section: | 67 | Flight Information Service Manual | 36 of 1999 | 01/07/1997 |
|----------|----|-----------------------------------|------------|------------|

Remarks:

Adaptation amendments retroactively made - see 36 of 1999 s. 3

A person shall not provide an aerodrome flight information service at any aerodrome unless:-

- (a) the service is provided in accordance with the standards and procedures specified in an aerodrome flight information service manual in respect of that aerodrome;
- (b) the manual is produced to the Chief Executive within a reasonable time after a request for its production is made by the Chief Executive;
- (c) such amendments or additions as the Chief Executive may from time to time require have been made to the manual.

(36 of 1999 s. 3)

| | | | | |
|----------|----|---------------------------------------|------------|------------|
| Section: | 68 | Incapacity of air traffic controllers | 36 of 1999 | 01/07/1997 |
|----------|----|---------------------------------------|------------|------------|

Remarks:

Adaptation amendments retroactively made - see 36 of 1999 s. 3

(1) Every holder of an air traffic controller's licence granted under Article 65 of this Order who-

- (a) suffers any personal injury or illness involving incapacity to undertake the functions to which his licence relates throughout a period of 20 consecutive days; or

(b) in the case of a woman, who has reason to believe that she is pregnant, shall inform the Chief Executive in writing of such injury, illness or pregnancy as soon as possible.

(2) An air traffic controller's licence shall be deemed to be suspended upon the elapse of such period of injury or illness as is referred to in paragraph (1)(a) of this Article. The suspension of the licence shall cease:

- (a) upon the holder being medically examined under arrangements made by the Chief Executive and pronounced fit to resume his functions under the licence; or
- (b) upon the Chief Executive exempting the holder from the requirement of a medical examination subject to such condition as the Chief Executive may think fit.

(3) Upon the pregnancy of the holder of an air traffic controller's licence being confirmed, the licence shall be deemed to be suspended and such suspension may be lifted by the Chief Executive subject to such conditions as he thinks fit, and shall cease upon the holder being medically examined under arrangements made by the Chief Executive after the pregnancy has ended and pronounced fit to resume her functions under the licence.

(36 of 1999 s. 3)

| | | | | |
|----------|----|--------------------------------------|------------|------------|
| Section: | 69 | Power to prohibit or restrict flying | 36 of 1999 | 01/07/1997 |
|----------|----|--------------------------------------|------------|------------|

Remarks:

Adaptation amendments retroactively made - see 36 of 1999 s. 3

(1) (a) Subject to paragraphs (4) and (5) of this Article, where the Chief Executive deems it necessary in the public interest to restrict or prohibit by reason of- (66 of 1997 s. 13)

- (i) the intended gathering or movement of a large number of persons; or
- (ii) the intended holding of an aircraft race or contest or of an exhibition of flying; or

(iii) any other reason affecting the public interest, (66 of 1997 s. 13) the Chief Executive may make regulations prohibiting, restricting or imposing conditions on flight-

(aa) by any aircraft, whether or not registered in Hong Kong, in any airspace over Hong Kong;

(bb) by aircraft registered in Hong Kong, in any other airspace, being airspace in respect of which the Government of the Hong Kong Special Administrative Region has in pursuance of international arrangements undertaken to provide navigation services for aircraft.

(b) Regulations made under this Article may apply either generally or in relation to any class of aircraft. (36 of 1999 s. 3)

(2) If the commander of an aircraft becomes aware that the aircraft is flying in contravention of any regulations which have been made for any of the reasons referred to in paragraph (1)(a)(iii) of this Article he shall unless otherwise instructed pursuant to paragraph (3) of this Article cause the aircraft to leave the area to which the regulations relate by flying to the least possible extent over such area and the aircraft shall not begin to descend while over such an area.

(3) The commander of an aircraft flying either within an area for which regulations have

been made for any of the reasons referred to in paragraph (1)(a)(iii) of this Article or within airspace notified as a Danger Area shall forthwith comply with instructions given by radio or by one of the prescribed visual signals by the appropriate air traffic control unit or by, or on behalf of, the person responsible for safety within the relevant airspace.

(4) No regulations may be made under paragraph (1)(a) of this Article prohibiting flight by any aircraft in any airspace over Hong Kong-

- (a) by reason of national defence; or
- (b) during a state of emergency or state of war,

except on an instruction of a Secretary of State issued as described in paragraph (5) of this Article. (66 of 1997 s. 13)

(5) Where a Secretary of State, by reason of national defence, or at any time during a state of emergency or state of war, issues an instruction to the Governor-

- (a) that regulations be made under paragraph (1)(a) of this Article in accordance with the instruction; or
- (b) that regulations made under paragraph (1)(a) of this Article be repealed or amended in accordance with the instruction,

then the Governor shall comply with that instruction. (66 of 1997 s. 13)

| | | | | |
|----------|----|--|------------|------------|
| Section: | 70 | Balloons, kites, airships, gliders and parascending parachutes | 36 of 1999 | 01/07/1997 |
|----------|----|--|------------|------------|

Remarks:

Adaptation amendments retroactively made - see 36 of 1999 s. 3

(1) Within Hong Kong-

- (a) a captive balloon or kite shall not be flown at a height of more than 60 metres above the ground level or within 60 metres of any vessel, vehicle or structure;
- (b) a captive balloon shall not be flown within five kilometres of an aerodrome;
- (c) a balloon exceeding two metres in any linear dimension at any stage of its flight, including any basket or other equipment attached to the balloon, shall not be flown in controlled airspace;
- (d) a kite shall not be flown within five kilometres of an aerodrome;
- (e) an airship shall not be moored;
- (f) a glider or parascending parachute shall not be launched by which and cable or by ground or sea tow to a height of more than 60 metres above ground or sea level;
- (g) a parascending parachute shall not be launched within five kilometres of an airfield;

without the permission in writing of the Chief Executive and in accordance with any conditions subject to which that permission may be granted. (36 of 1999 s. 3)

(2) A captive balloon when not in flight shall be securely moored, shall not be left unattended and shall be fitted with a device which ensures its automatic deflation if it breaks free of its moorings.

| | | | | |
|----------|----|--|--|------------|
| Section: | 71 | Aerodromes: public transport of passengers and instruction in flying | | 30/06/1997 |
|----------|----|--|--|------------|

PART IX

**AERODROMES, AERONAUTICAL LIGHTS
AND DANGEROUS LIGHTS**

(1) An aircraft to which this paragraph applies shall not take-off or land at a place in Hong

Kong other than-

- (a) an aerodrome licensed under this Order for the take-off and landing of such aircraft; or
 - (b) a government aerodrome notified as available for the take-off and landing of such aircraft, or in respect of which the person in charge of the aerodrome has given his permission for the particular aircraft to take-off or land as the case may be,
- and in accordance with any condition subject to which the aerodrome may have been so licensed or notified, or subject to which such permission may have been given.

(2) Paragraph (1) of this Article applies to-

- (a) aeroplanes of which the maximum total weight authorised exceeds 2730 kg and which are flying-
 - (i) for the purpose of the public transport of passengers; or
 - (ii) for the purpose of instruction in flying given to any person for the purpose of becoming qualified for the grant of a pilot's licence or the inclusion of an aircraft rating or a night rating in a licence; or
 - (iii) for the purpose of carrying out flying tests in respect of the grant of a pilot's licence or the inclusion of an aircraft rating or a night rating in a licence;
 - (b) aeroplanes of which the maximum total weight authorized does not exceed 2730 kg engaged on either-
 - (i) scheduled journeys for the purpose of the public transport of passengers; or
 - (ii) flights for the purpose of the public transport of passengers beginning and ending at the same aerodrome; or
 - (iii) flights for the purpose of-
 - (aa) instruction in flying given to any person for the purpose of becoming qualified for the grant of a pilot's licence or the inclusion of an aircraft rating or a night rating in a licence; or
 - (bb) a flying test in respect of the grant of a pilot's licence or the inclusion of an aircraft rating or a night rating in a licence; or
 - (iv) flights for the purpose of the public transport of passengers at night;
 - (c) helicopters and gyroplanes engaged on such flights as are specified in sub-paragraphs (b)(i), (ii) and (iii) above;
 - (d) gliders (other than gliders being flown under arrangements made by a flying club and carrying no person other than a member of the club) which are flying for the purpose of the public transport of passengers or for the purpose of instruction in flying.
- (3) (a) The person in charge of any area in Hong Kong intended to be used for the taking-off or landing of helicopters at night other than such a place as is specified in paragraph (1) of this Article shall cause to be in operation, whenever a helicopter flying for the purpose of public transport of passengers is taking-off or landing at that area by night, such lighting as will enable the pilot of the helicopter-
- (i) in the case of landing, to identify the landing area in flight, to determine the landing direction and to make a safe approach and landing;
 - (ii) in the case of taking-off, to make a safe take-off.
- (b) A helicopter flying for the purpose of the public transport of passengers at night shall not take-off or land at a place to which sub-paragraph (a) of this paragraph applies unless there is in operation such lighting.

| | | | | |
|----------|----|-----------------------------|------------|------------|
| Section: | 74 | Aeronautical radio stations | 36 of 1999 | 01/07/1997 |
|----------|----|-----------------------------|------------|------------|

Remarks:

Adaptation amendments retroactively made - see 36 of 1999 s. 3

- (1) A person shall not cause or permit any aeronautical radio station to be established or

used unless its purpose has been approved by the Chief Executive and the equipment thereof is of a type the specification of which is approved by the Chief Executive in relation to the purpose for which it is to be used.

(2) The person in charge of an aeronautical radio station the purpose of which is to provide navigational aid by radio or radar to an aircraft making an approach to land or landing at an aerodrome shall not cause or permit that aeronautical radio station to provide such navigational aid unless all aeronautical radio stations operated by that person at that aerodrome are:

- (a) installed, modified and maintained in a manner approved by the Chief Executive; and
- (b) flight checked by the Chief Executive or by a person approved by the Chief Executive for that purpose on such occasions as the Chief Executive may require:

Provided that the provisions of this paragraph shall not apply to any aeronautical radio station which is used solely for the purpose of enabling communications to be made by or on behalf of the operator of an aircraft and the commander thereof.

(3) The person in charge of an aeronautical radio station at an aerodrome for which a licence for public use has been granted shall cause to be notified in relation to that aeronautical radio station the type and hours of operation of any service which is available for use by any aircraft, and in approving the purpose for which an aeronautical radio station is to be used at any other aerodrome the Chief Executive may if he thinks fit require the person in charge of the aeronautical radio station to cause such information as aforesaid to be notified.

(4) The provisions of this Article shall not apply in respect of any aeronautical radio station of which the person in charge is the Chief Executive.

(36 of 1999 s. 3)

| | | | | |
|----------|----|------------------------------------|------------|------------|
| Section: | 75 | Aeronautical radio station records | 36 of 1999 | 01/07/1997 |
|----------|----|------------------------------------|------------|------------|

Remarks:

Adaptation amendments retroactively made - see 36 of 1999 s. 3

(1) The person in charge of any aeronautical radio station the purpose of which is to provide navigational aid by radio or radar to an aircraft making an approach to land or landing at an aerodrome shall in respect of all aeronautical radio stations operated by him at that aerodrome:

- (a) keep a written record of functional tests, flight checks and particulars of any overhaul, repair, replacement or modification thereof; and
- (b) preserve the written record for a period of one year or such longer periods as the Chief Executive may in a particular case direct and shall within a reasonable time after being requested to do so by an authorised person produce such record to that person. (36 of 1999 s. 3)

(2) The person in charge of an aeronautical radio station which is used for the provision of an air traffic control service by an air traffic control unit shall provide apparatus which is capable of recording the terms of content of any radio message or signal transmitted to any aircraft either alone or in common with other aircraft or received from any aircraft by the air traffic control unit.

(3) The apparatus provided in compliance with paragraph (2) of this Article shall be:

- (a) of a type the specification of which is approved by the Chief Executive in relation to the particular aeronautical radio station; and
- (b) installed, modified and maintained in a manner approved by the Chief Executive; and
- (c) in operation at all times when the aeronautical radio station is in operation for providing an air traffic control service. (36 of 1999 s. 3)

(4) The person in charge of an aeronautical radio station shall ensure that each record made by the apparatus provided in compliance with paragraph (2) of this Article includes:

- (a) the identification of the aeronautical radio station; and
- (b) the date or dates on which the record was made; and

- (c) a means of determining the time at which each message or signal was transmitted; and
- (d) the identity of the aircraft to or from which and the radio frequency on which the message or signal was transmitted or received; and
- (e) the time at which the record started and finished.

(5) If at any time the apparatus provided in compliance with paragraph (2) of this Article ceases to be capable of recording the matters required by this Article to be included in the record the person in charge of the aeronautical station shall ensure that a written record is kept in which the particulars specified in paragraph (4) of this Article are recorded together with a summary of communications exchanged between the aeronautical radio station and aircraft.

(6) The person in charge of the aeronautical radio station shall preserve any record made in compliance with paragraphs (2) and (5) of this Article for a period of 30 days from the date on which the message or signal was recorded or for such longer period as the Chief Executive may in a particular case direct, and shall, within a reasonable time after being requested to do so by an authorized person, produce such record to that person. (36 of 1999 s. 3)

(7) A person required by this Article to preserve any record by reason of his being the person in charge of the aeronautical radio station shall, if he ceases to be such person, continue to preserve the record as if he had not ceased to be such person, and in the event of his death the duty to preserve the record shall fall upon his personal representative:

Provided that if another person becomes the person in charge of the aeronautical radio station the previous person in charge or his personal representative shall deliver the record to that other person on demand, and it shall be the duty of that other person to deal with the record delivered to him as if he were that previous person in charge.

(8) The provisions of this Article shall not apply in respect of any aeronautical radio station of which the person in charge is the Chief Executive. (36 of 1999 s. 3)

| | | | | |
|----------|----|---------------------|------------|------------|
| Section: | 79 | Aeronautical lights | 36 of 1999 | 01/07/1997 |
|----------|----|---------------------|------------|------------|

Remarks:

Adaptation amendments retroactively made - see 36 of 1999 s. 3

(1) Except with the permission of the Chief Executive and in accordance with any conditions subject to which the permission may be granted, a person shall not establish, maintain or alter the character of;

- (a) an aeronautical beacon within Hong Kong:

Provided that, in the case of an aeronautical beacon which is or may be visible from the waters within an area of a lighthouse authority, the Chief Executive shall not give permission for the purpose of this Article except with the consent of that authority, or

- (b) any aeronautical ground light (other than an aeronautical beacon) at an aerodrome licensed under this Order, or which forms part of the lighting system for use by aircraft taking off from or landing at such an aerodrome.

(2) A person shall not intentionally or negligently damage or interfere with any aeronautical ground light established by or with the permission of the Chief Executive.

(36 of 1999 s. 3)

| | | | | |
|----------|----|--|------------|------------|
| Section: | 85 | Flights over any place outside Hong Kong | 23 of 1998 | 01/07/1997 |
|----------|----|--|------------|------------|

Remarks:

Adaptation amendments retroactively made - see 23 of 1998 s. 2

- (1) The operator or commander of an aircraft registered in Hong Kong (or, if the operator's

principal place of business or permanent residence is in Hong Kong, any other aircraft) which is being flown over any place outside Hong Kong shall not allow that aircraft to be used for a purpose which is prejudicial to the security, public order or public health of, or to the safety of air navigation in relation to, that place. (23 of 1998 s. 2)

(2) A person does not contravene paragraph (1) of this Article if he neither knew nor suspected that the aircraft was being or was to be used for a purpose referred to in paragraph (1).

(3) The operator or commander of an aircraft registered in Hong Kong (or, if the operator's principal place of business or permanent residence is in Hong Kong, any other aircraft) which is being flown over any place outside Hong Kong shall comply with any directions given by the appropriate aeronautical authorities of that place whenever-

- (a) the flight has not been duly authorized; or
- (b) there are reasonable grounds for the appropriate aeronautical authorities to believe that the aircraft is being or will be used for a purpose which is prejudicial to the security, public order or public health of, or to the safety of air navigation in relation to, that place;

unless the lives of person on board or the safety of the aircraft would thereby be endangered. (23 of 1998 s. 2)

(4) A person does not contravene paragraph (3) of this Article if he neither knew nor suspected that directions were being given by the appropriate aeronautical authorities.

(5) The requirements in paragraph (3) of this Article is without prejudice to any other requirement to comply with directions of an aeronautical authority.

(6) In this Article "appropriate aeronautical authorities" includes any person, whether a member of military or civil authorities of a place outside Hong Kong, authorized under the law of that place to issue directions to aircraft flying over that place. (23 of 1998 s. 2)

| | | | | |
|----------|----|---------------------|------------|------------|
| Section: | 86 | Mandatory reporting | 36 of 1999 | 01/07/1997 |
|----------|----|---------------------|------------|------------|

Remarks:

Adaptation amendments retroactively made - see 36 of 1999 s. 3

- (1) Subject to the provisions of this Article, every person who-
- (a) is the operator or the commander of a public transport aircraft which is registered in Hong Kong and has a maximum total weight authorized of more than 2300 kg; or
 - (b) carries on the business of manufacturing, repairing or overhauling such an aircraft, or any equipment or part thereof; or
 - (c) signs a certificate of maintenance review, or of release to service in respect of such an aircraft, part or equipment; or
 - (d) performs a function for which he requires an air traffic controller's licence; or
 - (e) is the licensee or manager of a licensed aerodrome,
- shall-
- (i) make a report to the Chief Executive of any reportable occurrence of which he knows and which is of such a description as is specified in Regulation 16 in Schedule 15 to this Order. The report shall be made within such time, by such means, and shall contain such information as is so specified and it shall be presented in such form as the Chief Executive may in any particular case approve, and
 - (ii) make a report to the Chief Executive, within such time, by such means, and containing such information as the Chief Executive may specify in a notice in writing served upon him, being information which is in his possession or control and which relates to a reportable occurrence which has been reported by him or by another person to the Chief Executive in accordance with this Article.
- (2) In this Article "reportable occurrence" means-

- (a) any incident relating to such an aircraft or any defect in or malfunctioning of such an aircraft or any part or equipment of such an aircraft, being an incident, malfunctioning or defect endangering, or which if not corrected would endanger, the aircraft, its occupants, or any other person; and
- (b) any defect in or malfunctioning of any facility on the ground used or intended to be used for purposes of or in connection with the operation of such an aircraft, being a defect or malfunctioning endangering, or which if not corrected would endanger, such an aircraft or its occupants:

Provided that any accident notified to the Chief Executive in pursuance of regulations made under the Hong Kong Civil Aviation (Investigation of Accidents) Regulations 1983, as amended, shall not constitute a reportable occurrence for the purposes of this Article.

(3) Subject to paragraph (1)(ii) of this Article, nothing in this Article shall require a person to report any occurrence which he has reason to believe has been or will be reported by another person to the Chief Executive in accordance with this Article.

(4) A person shall not make any report under this Article if he knows or has reason to believe that the report is false in any particular.

(5) Without prejudice to Article 37(2), (4) and (5) and subject to the provisions of Article 61 of this Order, the operator of an aircraft shall, if he has reason to believe that a report has been or will be made in pursuance of this Article, preserve any data from a flight data recorder or a combined cockpit voice recorder/flight data recorder relevant to the reportable occurrence for fourteen days from the date on which a report of that occurrence is made to the Chief Executive or for such longer period as the Chief Executive may in a particular case direct:

Provided that the record may be erased if the aircraft is outside Hong Kong and it is not reasonably practicable to preserve the record until the aircraft reaches Hong Kong.

(36 of 1999 s. 3)

| | | | | |
|----------|----|----------------------------------|------------|------------|
| Section: | 87 | Power to prevent aircraft flying | 36 of 1999 | 01/07/1997 |
|----------|----|----------------------------------|------------|------------|

Remarks:

Adaptation amendments retroactively made - see 36 of 1999 s. 3

(1) If it appears to the Chief Executive or an authorized person that any aircraft is intended or likely to be flown-

- (a) in such circumstances that any provision of Article 3, 5, 6, 7, 18, 19, 28, 37, 43 or 44 of this Order would be contravened in relation to the flight; or
- (b) in such circumstances that the flight would be in contravention of any other provision of this Order or any regulations made thereunder and be a cause of danger to any person or property whether or not in the aircraft; or
- (c) while in a condition unfit for the flight, whether or not the flight would otherwise be in contravention of any provision of this Order or of any regulation made thereunder,

the Chief Executive or that authorized person may direct the operator or the commander of the aircraft that he is not to permit the aircraft to make the particular flight or any other flight of such description as may be specified in the direction, until the direction has been revoked by the Chief Executive or by an authorized person, and the Chief Executive or that authorized person may take such steps as are necessary to detain the aircraft.

(2) For the purposes of paragraph (1) of this Article the Chief Executive or any authorized person may enter upon and inspect any aircraft.

(3) If it appears to the Chief Executive or an authorized person that any aircraft is intended or likely to be flown in such circumstances that any provision of Article 84 or 85 of this Order or any provision relating to the licensing of air transport in Hong Kong would be contravened in relation to the flight, the Chief Executive or that authorized person may direct the operator or the commander of the aircraft that he is not to permit the aircraft to make the particular flight or any

other flight of such description as may be specified in the direction until the direction has been revoked by the Chief Executive or by an authorized person, and the Chief Executive or any authorized person may take such steps as are necessary to detain the aircraft.

(4) For the purposes of paragraph (3) of this Article the Chief Executive or any authorized person may enter upon any aerodrome and may enter upon and inspect any aircraft.

(36 of 1999 s. 3)

| | | | | |
|----------|----|-----------|--|------------|
| Section: | 91 | Penalties | | 30/06/1997 |
|----------|----|-----------|--|------------|

(1) If any provision of this Order or of any regulations made thereunder is contravened in relation to an aircraft, the operator of that aircraft and the commander thereof shall (without prejudice to the liability of any other person under this Order for that contravention) be deemed for the purposes of the following provisions to have contravened that provision unless he proves that the contravention occurred without his consent or connivance and that he exercised all due diligence to prevent the contravention.

(2) If it is proved that an act or omission of any person which would otherwise have been a contravention by that person of a provision of this Order or of any regulations made thereunder was due to any cause not avoidable by the exercise of reasonable care by that person the act or omission shall be deemed not to be a contravention by that person of that provision.

(3) Where a person is charged with contravening a provision of this Order or of any regulations made thereunder by reason of his having been a member of the flight crew of an aircraft on a flight for the purpose of public transport or aerial work the flight shall be treated (without prejudice to the liability of any other person under this Order) as not having been for that purpose if he proves that he neither knew nor suspected that the flight was for that purpose.

(4) If any person contravenes any provision of this Order, or of any regulations made thereunder, not being a provision referred to in paragraphs (5) or (6) of this Article, he shall be guilty of an offence and liable on summary conviction to a fine not exceeding \$2500.

(5) If any person contravenes any provision specified in Part A of Schedule 13 to this Order he shall be guilty of an offence and liable on summary conviction to a fine not exceeding \$5000.

(6) If any person contravenes any provision specified in Part B of the said Schedule he shall be guilty of an offence and liable on summary conviction to a fine not exceeding \$5000 and on conviction on indictment to a fine or imprisonment for a term not exceeding two years or both.

| | | | | |
|----------|----|---|------------|------------|
| Section: | 93 | Application of Order to Chinese controlled aircraft not registered in Hong Kong | 36 of 1999 | 01/07/1997 |
|----------|----|---|------------|------------|

Remarks:

Adaptation amendments retroactively made - see 36 of 1999 s. 3

The Chief Executive may direct that such of the provisions of this Order and of any regulations made or having effect thereunder as may be specified in the direction shall have effect as if reference in those provisions to aircraft registered in Hong Kong included references to the aircraft specified in the direction, being an aircraft not so registered but for the time being under the management of a person who, or of persons each of whom, is qualified to hold a legal or beneficial interest by way of ownership in an aircraft registered in Hong Kong.

(36 of 1999 s. 3)

| | | | | |
|----------|----|----------------------|--|------------|
| Section: | 96 | Appeal to High Court | L.N. 362 of 1997; 25 of 1998; 36 of 1999 | 01/07/1997 |
|----------|----|----------------------|--|------------|

Remarks:

Adaptation amendments retroactively made - see 25 of 1998 s. 2; 36 of 1999 s. 3

(1) An appeal shall lie to the Court of First Instance of Hong Kong from any decision of the Chief Executive that a person is not a fit person to hold a licence to act as an aircraft maintenance engineer, member of the flight crew of an aircraft, air traffic controller, student air traffic controller or aerodrome flight information service officer, and if the court is satisfied that on the evidence submitted to the Chief Executive he was wrong in so deciding, the court may reverse the Chief Executive's decision and the Chief Executive shall give effect to the court's determination: (25 of 1998 s. 2)

Provided that an appeal shall not lie from a decision of the Chief Executive that a person is not qualified to hold the licence by reason of a deficiency in his knowledge, experience, competence, skill, physical or mental fitness.

(2) The respondent to any appeal under this Article shall be the Secretary for Justice of Hong Kong. (L.N. 362 of 1997)

(3) For the purposes of any provision relating to the time within which an appeal may be brought, the Chief Executive's decision shall be deemed to have been taken on the date on which the Chief Executive furnished a statement of his reasons for the decision to the applicant for the licence, or as the case may be, the holder or former holder of it.

(36 of 1999 s. 3)

| | | | | |
|----------|----|----------------|------------------------|------------|
| Section: | 98 | Interpretation | 28 of 1998; 36 of 1999 | 01/07/1997 |
|----------|----|----------------|------------------------|------------|

Remarks:

Adaptation amendments retroactively made - see 28 of 1998 s. 2; 36 of 1999 s. 3

(1) In this Order, unless the context otherwise requires-

"Aerial work" means any purpose (other than public transport) for which an aircraft is flown if hire or reward is given or promised in respect of the flight or the purpose of the flight;

"Aerial work aircraft" means an aircraft (other than a public transport aircraft) flying, or intended by the operator to fly, for the purpose of aerial work;

"Aerial work undertaking" means an undertaking whose business includes the performance of aerial work;

"Aerobatic manoeuvres" includes loops, spins, rolls, bunts, stall turns, inverted flying and any other similar manoeuvre;

"Aerodrome flight information unit" means a person appointed by the Chief Executive or by any other person maintaining an aerodrome to give information by means of radio signals to aircraft flying or intending to fly within the aerodrome traffic zone of that aerodrome and "aerodrome flight information service" shall be construed accordingly; (36 of 1999 s. 3)

"Aerodrome operating minima" in relation to the operation of an aircraft at an aerodrome means the cloud ceiling and runway visual range for take-off, and the decision height or minimum descent height, runway visual range and visual reference for landing, which are the minima for the operation of that aircraft at that aerodrome;

"Aerodrome traffic zone" means the airspace:

(a) which is in the vicinity of an aerodrome which is notified for the purposes of Rule 35 of Schedule 14 to this Order; and

(b) which in relation to such an aerodrome:

(i) at which the length of the longest runway is notified as 1850 metres or less, extends from the surface to a height of 2000 feet above the level of the aerodrome within the area bounded by the circle centred on the notified mid-point of the longest runway and having a radius of 2 nautical miles:

Provided that where such an aerodrome traffic zone would extend less than 1 1/2 nautical miles beyond the end of any runway at the aerodrome and

this proviso is notified as being applicable, sub-paragraph (ii) hereof shall apply as though the length of the longest runway is notified as greater than 1850 metres;

- (ii) at which the length of the longest runway is notified as greater than 1850 metres, the airspace extends from the surface to a height of 2000 feet above the level of the aerodrome within the area bounded by a circle centred on the notified mid-point of the longest runway and having a radius of 2 1/2 nautical miles;

except any part of that airspace which is within the aerodrome traffic zone of another aerodrome which is notified for the purposes of this Order as being the controlling aerodrome;

"Aeronautical beacon" means an aeronautical ground light which is visible either continuously or intermittently to designate a particular point on the surface of the earth;

"Aeronautical ground light" means any light specifically provided as an aid to air navigation, other than a light displayed on an aircraft;

"Aeronautical radio station" means a radio station on the surface, which transmits or receives signals for the purpose of assisting aircraft;

"Air traffic control unit" means a person appointed by the Chief Executive or by any other person maintaining an aerodrome or place to give instructions or advice or both instructions and advice by means of radio signals to aircraft in the interests of safety but does not include a person so appointed solely to give information to aircraft, and "Air traffic control service" shall be construed accordingly; (36 of 1999 s. 3)

"Air traffic service" shall include an air traffic control service and flight information service;

"Air transport undertaking" means an undertaking whose business includes the carriage by air of passengers or cargo for hire or reward;

"Approach to landing" means that portion of the flight of the aircraft, when approaching to land, in which it is descending below a height of 1000 feet above the relevant specified decision height or minimum descent height;

"Appropriate aeronautical radio station" means in relation to an aircraft an aeronautical radio station serving the area in which the aircraft is for the time being;

"Appropriate air traffic control unit" means in relation to an aircraft the air traffic control unit serving the area in which the aircraft is for the time being or the air traffic control unit serving the area in which the aircraft intends to enter and with which unit the aircraft is required to communicate prior to entering that area, as the case may be;

"Authorized person" means any person authorized by the Chief Executive either generally or in relation to a particular case or class of cases, and references to a person authorized by the Chief Executive include references to the holder for the time being of any office designated by the Chief Executive; (36 of 1999 s. 3)

"Beneficial interest" has the same meaning as in section 53 of the Merchant Shipping (Registration) Ordinance (Cap 415); (36 of 1999 s. 3)

"Cargo" includes mail and animals;

"Certificate of airworthiness" includes any validation thereof and any flight manual, performance schedule or other document, whatever its title, incorporated by reference in that certificate relating to the certificate of airworthiness;

"Certificate of maintenance review" and "certificate of release to service" have the meanings respectively assigned to them by Articles 9(1) and 11(5) of this Order;

"Chief Executive" means-

- (a) the Chief Executive of the Hong Kong Special Administrative Region;
- (b) a person for the time being assuming the duties of the Chief Executive according to the provisions of Article 53 of the Basic Law; and
- (c) in relation to any purpose of this Order, other than the purposes of Article 97 thereof, any person authorized by the Chief Executive for that purpose; (36 of 1999 s. 3)

"Class A Airspace", "Class B Airspace", "Class C Airspace", "Class D Airspace", and "Class E Airspace" means airspace respectively notified as such;

- "Cloud ceiling" in relation to an aerodrome means the vertical distance from the elevation of the aerodrome to the lowest part of any cloud visible from the aerodrome which is sufficient to obscure more than one-half of the sky so visible;
- "Commander" in relation to an aircraft means the member of the flight crew designated as commander of that aircraft by the operator thereof, or, failing such a person, the person who is for the time being the pilot in command of the aircraft;
- "Competent authority" means in relation to Hong Kong, the Chief Executive, and in relation to any other country the authority responsible under the law of that country for promoting the safety of civil aviation; (36 of 1999 s. 3)
- "Conditional sale agreement" means an agreement for the sale of goods under which the purchase price or part of it is payable by instalments, and the property in the goods is to remain in the seller (notwithstanding that the buyer is to be in possession of the goods) until such conditions as to the payment of instalments or otherwise as may be specified in the agreement are fulfilled;
- "Congested area" in relation to a city, town or settlement, means any area which is substantially used for residential, industrial, commercial or recreational purposes;
- "Contracting State" means any State (including the People's Republic of China and Hong Kong, being a part thereof) which is a party to the Convention on International Civil Aviation which, on 7 December 1944, was opened for signature at the International Civil Aviation Conference held at Chicago; (36 of 1999 s. 3)
- "Controlled airspace" means airspace which has been notified as Class A, Class B, Class C, Class D or Class E airspace;
- "Control area" means airspace which has been notified as such and which extends upwards from a notified altitude or flight level;
- "Control zone" means airspace which has been notified as such and which extends upwards from the surface;
- "Co-pilot" in relation to an aircraft means a pilot who in performing his duties as such is subject to the direction of another pilot carried in the aircraft;
- "Country" includes a territory or place, except in paragraph (2) of this Article; (36 of 1999 s. 3)
- "Crew" has the meaning assigned to it by paragraph (4) of this Article;
- "Danger Area" shall mean airspace which has been notified as such within which activities dangerous to the flight or aircraft may take place or exist at such times as may be notified;
- "Decision height" in relation to the operation of an aircraft at an aerodrome means the height in a precision approach at which a missed approach must be initiated if the required visual reference to continue that approach has not been established;
- "Flight" and "to fly" have the meanings respectively assigned to them by paragraph (3) of this Article;
- "Flight crew" in relation to an aircraft means those members of the crew of the aircraft who respectively undertake to act as pilot, flight navigator, flight engineer and flight radio operator of the aircraft;
- "Flight level" means one of a series of levels of equal atmospheric pressure, separated by notified intervals and each expressed as the number of hundreds of feet which would be indicated at that level on a pressure altimeter calibrated in accordance with the International Standard Atmosphere and set to 1013.2 millibars;
- "Flight recording systems" means a system comprising either a flight data recorder or a cockpit voice recorder or both;
- "Flight simulator" means apparatus by means of which flight conditions in an aircraft are simulated on the ground;
- "Flight visibility" means the visibility forward from the flight deck of an aircraft in flight;
- "Government aerodrome" means any aerodrome in Hong Kong which is under the control of the Chief Executive or is in the occupation of any department of the Government of the Hong Kong Special Administrative Region, or of Her Majesty's naval, military or air forces, or of any visiting force; (36 of 1999 s. 3)
- "Hong Kong" includes-
- (a) all waters, whether navigable or not, included in Hong Kong; and

(b) (Repealed 36 of 1999 s. 3)

"hire-purchase agreement" means an agreement for the bailment of goods under which the bailee may buy the goods, or under which the property in the goods will or may pass to the bailee;

"Instrument Flight Rules" means Instrument Flight Rules contained in the Rules of the Air;

"Instrument Meteorological Conditions" means weather precluding flight in compliance with the Visual Flight Rules;

"To land" in relation to aircraft includes alighting on the water;

"Legal personal representative" means the person constituted executor, administrator, or other representative, of a deceased person; (36 of 1999 s. 3)

"Licence" includes any certificate of competency or certificate of validity issued with the licence or required to be held in connection with the licence by the law of the country in which the licence is granted;

"Licence for public use" has the meaning assigned to it by Article 73(3) of this Order;

"Licensed aerodrome" means an aerodrome licensed under this Order;

"Lifejacket" includes any device designed to support a person individually in or on the water;

"Log Book" in the case of an aircraft log book, engine log book variable pitch propeller log book or personal flying log book, includes a record kept either in a book, or by any other means approved by the Chief Executive in the particular case; (36 of 1999 s. 3)

"Maximum total weight authorized" in relation to an aircraft means the maximum total weight of the aircraft and its contents at which the aircraft may take off anywhere in the world, in the most favourable circumstances in accordance with the certificate of airworthiness in force in respect of the aircraft;

"Military aircraft" includes the naval, military or air force aircraft of any country and-

(a) any aircraft being constructed for the naval, military or air forces of any country under a contract entered into by the Secretary of State; and

(b) any aircraft in respect of which there is in force a certificate issued by the Secretary of State that the aircraft is to be treated for the purposes of this Order as a military aircraft;

"Minimum descent height" in relation to the operation of an aircraft at an aerodrome means the height in a non-precision approach below which descent may not be made without the required visual reference;

"Nautical mile" means the International Nautical Mile, that is to say, a distance of 1852 metres;

"Night" means the time between half an hour after sunset and half an hour before sunrise, sunset and sunrise being determined at surface level;

"Non-precision approach" means an instrument approach using non-visual aids for guidance in azimuth or elevation but which is not a precision approach;

"Notified" means shown in any of the following publications for the time being in force and issued in Hong Kong whether before or after the coming into operation of this Order, that is to say "Notams (Notices to Airmen)", "Aeronautical Information Publications (AIP)", or such other official publications so issued for the purpose of enabling any of the provisions of this Order to be complied with;

"Operator" has the meaning assigned to it by paragraph (5) of this Article;

"Parascending parachute" means a parachute which is towed by cable in such a manner as to cause it to ascend;

"Passenger" means a person other than a member of the crew;

"Pilot in command" in relation to an aircraft means a person who for the time being is in charge of the piloting of the aircraft without being under the direction of any other pilot in the aircraft;

"Precision approach" means an instrument approach using Instrument Landing System, Microwave Landing System or Precision Approach Radar for guidance in both azimuth and elevation;

"Prescribed" means prescribed by regulations made by the Chief Executive under this Order, and the expression "prescribe" shall be construed accordingly; (36 of 1999 s. 3)

"Pressurised aircraft" means an aircraft provided with means of maintaining in any compartment a pressure greater than that of the surrounding atmosphere;

"Public transport" has the meaning assigned to it by paragraph (6) of this Article;

"Public transport aircraft" means an aircraft flying, or intended by the operator of the aircraft to fly, for the purpose of public transport;

"Record" includes, in addition to a record in writing-

- (a) any disc, tape, sound-track or other device in which sounds or signals are embodied so as to be capable (with or without the aid of some other instrument) of being reproduced therefrom;
- (b) any film, tape or other device in which visual images are embodied so as to be capable (as aforesaid) of being reproduced therefrom; and
- (c) any photograph;

and any reference to a copy of a record includes, in the case of a record falling within paragraph (a) only of this definition, a transcript of the sounds or signals embodied therein, in the case of a record falling within paragraph (b) only of this definition, a still reproduction of the images embodied therein, and in the case of a record falling within both those paragraphs; such a transcript together with such a still reproduction;

"Replacement" in relation to any part of an aircraft or its equipment includes the removal and replacement of that part whether or not by the same part, and whether or not any work is done on it, but does not include the removal and replacement of a part which is designed to be removable solely for the purpose of enabling another part to be inspected, repaired, removed or replaced or cargo to be loaded;

"Rules of the Air" means the Rules contained in Schedule 14 to this Order and any supplementary rules made by the Chief Executive under Article 64(1) of this Order; (36 of 1999 s. 3)

"Runway visual range" in relation to a runway means the distance in the direction of take-off or landing over which the runway lights or surface marking may be seen from the touchdown zone as calculated by either human observation or instruments in the vicinity of the touchdown zone or where this is not reasonably practicable in the vicinity of the midpoint of the runway; and the distance, if any, communicated to the commander of an aircraft by or on behalf of the person in charge of the aerodrome as being the runway visual range shall be taken to be the runway visual range for the time being;

"Scheduled journey" means one of a series of journeys which are undertaken between the same two places and which together amount to a systematic service;

"Seaplane" includes a flying boat and any other aircraft designed to manoeuvre on water;

"Special VFR flight" means a flight made in Instrument Meteorological Conditions or at night in a control zone or in a control zone notified for the purposes of Rule 22 of the Rules of the Air in respect of which the appropriate air traffic control unit has given permission for the flight to be made in accordance with special instructions by that unit instead of in accordance with the Instrument Flight Rules;

"Specified minimum weather provisions" has the meaning assigned to it by paragraph (7) of this Article;

"Visual Flight Rules" means Visual Flight Rules contained in the Rules of the Air;

"Visual Meteorological Conditions" means weather permitting flight in accordance with the Visual Flight Rules.

(66 of 1997 s. 15; 28 of 1998 s. 2; 36 of 1999 s. 3)

(2) In relation to Hong Kong the expression "visiting force" in this Order means any such body, contingent or detachment of the forces of any country as is a visiting force for the purposes of any of the provisions of the Visiting Forces Act 1952^(a), which extend to that territory, in respect of that country, by virtue of any Order in Council made under subsection (2) of section 1 or under section 15 of that Act.

(3) An aircraft shall be deemed to be in flight-

- (a) in the case of a piloted flying machine from the moment when, after the embarkation of its crew for the purpose of taking off, it first moves under its own power, until the moment when it next comes to rest after landing;
- (b) in the case of a pilotless flying machine, or a glider, from the moment when it first moves for the purpose of taking off until the moment when it next comes to rest after landing;

- (c) in the case of an airship or free balloon, from the moment when it first becomes detached from the surface until the moment when it next becomes attached thereto or comes to rest thereon;

and the expressions "a flight" and "to fly" shall be construed accordingly.

(4) Every person employed or engaged in an aircraft in flight on the business of the aircraft shall be deemed to be a member of the crew thereof.

(5) References in this Order to the operator of an aircraft are, for the purpose of the application of any provision of this Order in relation to any particular aircraft, references to the person who at the relevant time has the management of that aircraft, and cognate expressions shall be construed accordingly:

Provided that for the purposes of the application of any provision in Part III of this Order, when by virtue of any charter or other agreement for the hire or loan of an aircraft a person other than an air transport undertaking or an aerial work undertaking has the management of that aircraft for a period not exceeding 14 days, the foregoing provisions of this paragraph shall have effect as if that agreement had not been entered into.

(6) (a) Subject to the provisions of this paragraph, an aircraft in flight shall for the purposes of this Order be deemed to fly for the purpose of public transport-

(i) if hire or reward is given or promised for the carriage of passengers or cargo in the aircraft on that flight; or

(ii) if any passengers or cargo are carried gratuitously in the aircraft on that flight by an air transport undertaking, not being persons in the employment of the undertaking (including, in the case of a body corporate, its directors), persons with the authority of the Chief Executive either making any inspection or witnessing any training, practice or test for the purposes of this Order, or cargo intended to be used by any such passengers as aforesaid, or by the undertaking; or (36 of 1999 s. 3)

(iii) for the purposes of Part III of this Order, if hire or reward is given or promised for the right to fly the aircraft on that flight (not being a single seater aircraft of which the maximum total weight authorized does not exceed 910 kilograms and in respect of which a certificate of airworthiness of the Special Category is in force) otherwise than under a hire-purchase or conditional sale agreement,

and the expression "public transport of Passengers" shall be construed accordingly:

Provided that, notwithstanding that an aircraft may be flying for the purpose of public transport by reason of sub-paragraph (a)(iii) of this paragraph, it shall not be deemed to be flying for the purpose of the public transport of passengers unless hire or reward is given for the carriage of those passengers.

Provided that, notwithstanding that an aircraft may be flying for the purpose of public transport for the purposes of Part III of this Order by virtue of sub-paragraph (a)(iii) of this paragraph if the hire or reward given or promised for the primary purpose of conferring on a particular person the right to fly the glider on that flight is given or promised by a member of a flying club and the glider is owned or operated by that flying club.

(b) Where under a transaction effected by or on behalf of a member of an association of persons on the one hand and the association of persons or any member thereof on the other hand, a person is carried in, or is given the right to fly, an aircraft in such circumstances that hire or reward would be given or promised if the transaction were effected otherwise than aforesaid, hire or reward shall, for the purposes of this Order, be deemed to have been given or promised, notwithstanding any rule of law as to such transactions.

(7) The specified minimum weather provisions shall be as follows-

(a) Outside airspace notified for the purposes of Schedule 8 to this Order:

(i) an aircraft flying above 3000 feet above mean sea level shall remain at least 1800 metres horizontally and 1000 feet vertically away from cloud and in a flight visibility of at least 10 km:

(ii) an aircraft other than a helicopter flying at or below 3000 feet above mean

sea level shall remain at least 1800 metres horizontally and 1000 feet vertically away from cloud and in a flight visibility of at least 5 km:

Provided that this sub-paragraph shall be deemed to be complied with if the aircraft is flown at a speed which according to its airspeed indicator is 140 knots or less and remains clear of cloud, in sight of the surface and in a flight visibility of at least 1800 metres;

(iii) a helicopter flying at or below 3000 feet above mean sea level shall remain clear of cloud and in sight of the surface or at least 1800 metres horizontally and 1000 feet vertically away from cloud and in a flight visibility of at least 5 km;

(b) within airspace notified for the purposes of Schedule 8 to this Order an aircraft shall remain at least 1800 metres horizontally and 1000 feet vertically away from cloud and in a flight visibility of at least 10 km:

Provided that in a control zone within such airspace, in the case of a special VFR flight the aircraft shall be flown in accordance with any instructions given by the appropriate air traffic control unit.

(8) The expressions appearing in the "General Classification of Aircraft" set forth in Part A of Schedule 1 to this Order shall have the meanings thereby assigned to them.

(9) (Repealed 36 of 1999 s. 3)

(10) A power to make regulations under this Order shall include the power to make different provisions with respect to different circumstances and with respect to different parts of Hong Kong and to make such incidental and supplementary provisions as are necessary or expedient for carrying out the purposes of the Order.

(11) (a) Any power conferred by this Order to issue, make, serve or grant any instrument shall be construed as including a power exercisable, in the like manner and subject to the like conditions, if any, to vary, revoke, cancel or otherwise terminate the instrument.

(b) In this paragraph "instrument" includes any regulations, direction, instruction, rule or other requirement, any notice and any certificate, licence, approval, permission, exemption, authorization, log book record or other document.

(12) The Chief Executive may delegate any person or body or the person holding any office designated by him to exercise or perform on his behalf any of his powers or duties under this Order other than the power to make regulations under Article 97 and thereupon, or from the date specified by the Chief Executive, the person so delegated shall have and may exercise such powers and shall perform such duties, other than the power to make regulations under Article 97. (36 of 1999 s. 3)

Note:

(a) 1952 c. 67.

| | | | |
|-----------|---|------------------|------------|
| Schedule: | 1 | L.N. 560 of 1997 | 01/01/1998 |
|-----------|---|------------------|------------|

Article 4(6), 23(2) and 99(8)

PART A

TABLE OF GENERAL CLASSIFICATION OF AIRCRAFT

| Column 1 | Column 2 | Column 3 | Column 4 | |
|----------|-----------------------------------|--|---|-------------------------|
| Aircraft | { Lighter than air aircraft | { Non-power driven | { Free balloon Captive balloon | |
| | | | | Power driven |
| | { Heavier than air aircraft | { Non-power driven | { Aeroplane (Landplane) Aeroplane (Seaplane) Aeroplane (Amphibian) | Glider |
| | | | | Kite |
| | | { Power driven (flying machines) | { Aeroplane (Self- launching motor glider) | Rotorcraft (Helicopter) |
| | | | | Rotorcraft (Gyroplane) |

PART B

Article 5(2)

NATIONALITY AND REGISTRATION MARKS OF
AIRCRAFT REGISTERED IN HONG KONG

1. The nationality mark of the aircraft shall be the capital letter "B" in Roman character and the registration mark shall be a group of three capital letters in Roman character assigned by the Chief Executive on the registration of the aircraft. The letters shall be without ornamentation and a hyphen shall be placed between the nationality mark and the registration mark. (66 of 1997 s. 16; L.N. 560 of 1997)
2. The nationality and registration marks shall be displayed to the best advantage, taking into consideration the constructional features of the aircraft and shall always be kept clean and visible.
3. The letters constituting each group of marks shall be of equal height and they, and the hyphen, shall all be of the same single colour which shall clearly contrast with the background on which they appear.
4. The nationality and registration marks shall also be inscribed, together with the name and address of the registered owner of the aircraft, on a fireproof metal plate affixed in a prominent position-
 - (a) in the case of an aeroplane having an empty weight not exceeding 150 kg either in accordance with paragraph (c) or on the wing;
 - (b) in the case of a balloon, on the basket or envelope; or
 - (c) in the case of any other aircraft on the fuselage or car, as the case may be.
5. The nationality and registration marks shall be painted on the aircraft or shall be affixed thereto by any other means ensuring a similar degree of permanence in the following manner:
 - I. Position of marks
 - (a) Flying Machines and Gliders
 - (i) Horizontal Surfaces of the Wings or Fuselage (or equivalent structure).
 - (aa) On aircraft having a fixed wing surface, the marks shall appear on the

lower surface of the wing structure, and shall be on the left half of the lower surface of the wing structure unless they extend across the whole surface of both wings. So far as is possible the marks shall be located equidistant from the leading and trailing edges of the wings. The tops of the letters shall be towards the leading edge of the wing.

- (bb) On aircraft having no fixed wing surface and when owing to the structure of the aircraft the greatest height reasonably practicable for the marks on the vertical surface of the fuselage (or equivalent structure) is less than 15 centimetres the marks shall also appear on the lower surface of the fuselage on the line of symmetry and shall be placed with the tops of the letters towards the nose.
- (ii) Vertical Surfaces of the Tail or Fuselage (or equivalent structure): The marks shall also be on each side of the aircraft either on the fuselage or on the upper halves of the vertical tail surfaces. On aircraft having a fixed wing surface, the marks, if placed on the fuselage (or equivalent structure), shall be between the horizontal tail surfaces and the wing. When on a single vertical tail surface, the marks shall be on both sides. When there is more than one vertical tail surface, the marks shall be on the outer sides of the outboard vertical tail surfaces.
- (b) Airships and Free Balloons
 - (i) Airships: The marks shall be on each side of the airship. They shall be placed horizontally either on the hull near the maximum cross-section of the airship or on the lower vertical stabiliser.
 - (ii) Free Balloons: The marks shall be in two places diametrically opposite.
 - (iii) In the case of all airships and free balloons the side marks shall be so placed as to be visible both from the sides and from the ground.

II. Size of marks

- (a) Flying Machines and Gliders
 - (i) Wings: The letters constituting each group of marks shall be of equal height. The height of the letters shall be at least 50 centimetres.
 - (ii) Fuselage (or equivalent structure) or Vertical Tail Surfaces: The marks on the fuselage (or equivalent structure) shall not interfere with the visible outlines of the fuselage (or equivalent structure). The marks on the vertical tail surfaces shall be such as to leave a margin of at least 5 centimetres along each side of the vertical tail surface. The letters shall be of equal height. The height of the letters constituting each group of marks shall be at least 30 centimetres. Where marks are required to be carried out on the lower surface of aircraft having no fixed wing surface, the height of the marks shall be at least 50 centimetres:

Provided that where owing to the structure of the aircraft the appropriate height specified in this sub-paragraph (ii) is not reasonably practicable, the height of the marks shall be the greatest height reasonably practicable in the circumstances consistent with compliance with Section III of this Part of this Schedule.

- (b) Airships and Free Balloons
 - The letters constituting each group of marks shall be of equal height. The height of the letters shall be at least 50 centimetres.

III. Width and spacing of marks

- (a) The width of each letter (except the letter I) and the length of the hyphen between the nationality mark and registration mark shall be two-thirds of the height of a letter.

- (b) The letters and hyphen shall be formed by solid lines and shall be of a colour clearly contrasting with the background on which they appear. The thickness of the lines shall be one-sixth of the height of a letter.
- (c) Each letter shall be separated from the letter which it immediately precedes or follows by a space equal to half the width of a letter. A hyphen shall be regarded as a letter for this purpose.

PART C

Article 4(8)

AIRCRAFT DEALER'S CERTIFICATE-CONDITIONS

- (1) The operator of the aircraft shall be the registered owner of the aircraft, who shall be the holder of an aircraft dealer's certificate granted under this Order.
- (2) The aircraft shall fly only for the purpose of-
 - (a) testing the aircraft; or
 - (b) demonstrating the aircraft with a view to the sale of that aircraft or of other similar aircraft; or
 - (c) proceeding to or from a place at which the aircraft is to be tested or demonstrated as aforesaid, or overhauled, repaired or modified; or
 - (d) delivering the aircraft to a person who has agreed to buy, lease or sell it; or
 - (e) proceeding to or from a place for the purpose of storage.
- (3) Without prejudice to the provisions of Article 32 of this Order the operator of the aircraft shall satisfy himself before the aircraft takes off that the aircraft is in every way fit for the intended flight.
- (4) The aircraft shall fly only within Hong Kong.

| | | | | |
|-----------|---|--------------------|------------|------------|
| Schedule: | 2 | A AND B CONDITIONS | 36 of 1999 | 01/07/1997 |
|-----------|---|--------------------|------------|------------|

Remarks:

Adaptation amendments retroactively made - see 36 of 1999 s. 3

Articles 3(1), 7(1) and 39(7)

The A Conditions and B Conditions referred to in Article 3(1), 7(1) and 39(7) of this Order are as follows-

A Conditions

- (1) The aircraft shall be either an aircraft in respect of which a certificate of airworthiness or validation has previously been in force under this Order, or an aircraft identical in design with an aircraft in respect of which such a certificate is or has been in force.
- (2) The aircraft shall fly only for the purpose of enabling it to-
 - (a) qualify for the issue or renewal of a certificate of airworthiness or of the validation thereof or the approval of a modification of the aircraft, after an application has been made for each issue, renewal, validation or approval as the case may be;
 - (b) proceed to or from a place at which any inspection, approval, test or weighing of, or the installation of equipment in, the aircraft is to take place for a purpose referred to in sub-paragraph (a), after such an application has been made, or at which the installation of furnishings in, or the painting of, the aircraft is to be undertaken; or
 - (c) proceed to or from a place at which the aircraft is to be or has been stored.
- (3) The aircraft and its engines shall be certified as fit for flight by the holder of an aircraft

maintenance engineer's licence granted under this Order, being a licence which entitles him to issue that certificate or by a person approved by the Chief Executive for the purpose of issuing certificates under this condition, and in accordance with that approval. (36 of 1999 s. 3)

(4) The aircraft shall carry the minimum flight crew specified in any certificate of airworthiness or validation, which has previously been in force under this Order in respect of the aircraft, or is or has previously been in force in respect of any other aircraft of identical design.

(5) The aircraft shall not carry any persons or cargo except persons performing duties in the aircraft in connection with the flight or persons who are carried in the aircraft to perform duties in connection with a purpose referred to in paragraph (2) of these Conditions.

(6) The aircraft shall not fly over any congested area of a city, town or settlement except to the extent that it is necessary to do so in order to take off from or land at a Government aerodrome or a licensed aerodrome, in accordance with normal aviation practice.

(7) Without prejudice to the provisions of Article 18(2) of this Order, the aircraft shall carry such flight crew as may be necessary to ensure the safety of the aircraft.

B Conditions

(1) The flight shall be made under the supervision of a person approved by the Chief Executive for the purpose of these Conditions, and subject to any additional conditions which may be specified in such approval. (36 of 1999 s. 3)

(2) If it is not registered in Hong Kong or under the law of any country referred to in Article 3 of this Order, the aircraft shall be marked in a manner approved by the Chief Executive for the purposes of these Conditions, and the provisions of Articles 14, 15, 19, 32, 35, 57 and 59 of this Order shall be complied with in relation to the aircraft as if it was registered in Hong Kong so far as such provisions are applicable to the aircraft in the circumstances. (36 of 1999 s. 3)

(3) The aircraft shall fly only for the purpose of-

- (a) experimenting with or testing the aircraft (including in particular its engines) and its equipment;
- (b) enabling it to qualify for the issue of a certificate of airworthiness or the validation thereof, or the approval of a modification of the aircraft;
- (c) proceeding to or from a place at which any experiment, inspection, approval, test or weighing of, or the installation of equipment in, the aircraft is to take place for a purpose referred to in sub-paragraph (a) or (b), or at which the installation of furnishings in, or the painting of, the aircraft is to be undertaken; or
- (d) demonstrating the aircraft with a view to the sale of that aircraft or of other similar aircraft.

(4) Without prejudice to the provisions of Article 18(2) of this Order, the aircraft shall carry such flight crew as may be necessary to ensure the safety of the aircraft.

(5) The aircraft shall not carry any cargo, or any persons other than the flight crew except the following-

- (a) persons employed by the operator who carry out during the flight duties in connection with the purposes specified in paragraph (3) of these Conditions;
- (b) persons employed by manufacturers of component parts of the aircraft (including its engines) who carry out during the flight duties in connection with the purposes so specified;
- (c) persons approved by the Chief Executive under Article 101 of this Order as qualified to furnish reports for the purposes of Article 8 of this Order; (36 of 1999 s. 3)
- (d) persons, other than those carried under the preceding provisions of this paragraph, who are carried in the aircraft in order to carry out a technical evaluation of the aircraft or its operation.

(6) The aircraft shall not fly, except in accordance with procedures which have been approved by the Chief Executive in relation to that flight, over any congested area of a city, town or settlement. (36 of 1999 s. 3)

| | | | |
|-----------|---|------------------------|------------|
| Schedule: | 3 | CATEGORIES OF AIRCRAFT | 30/06/1997 |
|-----------|---|------------------------|------------|

Article 3

Transport Category (Passenger).
 Transport Category (Cargo).
 Aerial Work Category.
 Private Category.
 Special Category.

The purposes for which the aircraft may fly are as follows:

- Transport Category (Passenger): Any purpose.
- Transport Category (Cargo): Any purpose other than the public transport of passengers.
- Aerial Work Category: Any purpose other than public transport.
- Private Category: Any purpose other than public transport or aerial work.
- Special Category: Any purpose, other than public transport, specified in the certificate of airworthiness but not including the carriage of passengers unless expressly permitted.

| | | | |
|-----------|---|------------------|------------|
| Schedule: | 4 | AERODROME MANUAL | 30/06/1997 |
|-----------|---|------------------|------------|

Article 73

Information and instructions relating to the following matters shall be included in the aerodrome manual referred to in Article 73 of this Order:

- (i) the name and status of the official in charge of day to day operation of the aerodrome together with the names and status of other senior aerodrome operating staff and instructions as to the order and circumstances in which they may be required to act as the official in charge;
- (ii) the system of aeronautical information service available;
- (iii) procedures for promulgating information concerning the aerodrome's state;
- (iv) procedures for the control of access, vehicles and work in relation to the aerodrome manoeuvring area and apron;
- (v) procedures for complying with Article 86 of this Order and for the removal of disabled aircraft;
- (vi) in the case of an aerodrome which has facilities for fuel storage, procedures for complying with Article 82 of this Order;
- (vii) plans to a scale of 1:2500 depicting the layout of runways, taxiways and aprons, aerodrome markings, aerodrome lighting if such lighting is provided, and the siting of any navigational aids within the runway strip:

Provided that in the case of copies of the manual or extracts thereof provided or made available to a member of the aerodrome operating staff, the plans shall be of a scale reasonably appropriate for the purposes of Article 73(10) of this Order;

- (viii) in respect of an aerodrome in relation to which there is a notified instrument approach procedure, survey information sufficient to provide data for the production of aeronautical charts relating to that aerodrome;
- (ix) description, height and location of obstacles which infringe standard obstacle limitation surfaces, and whether they are lit;
- (x) data for and method of calculation of declared distances and elevations at the

- beginning and end of each declared distance;
- (xi) method of calculating reduced declared distances and the procedure for their promulgation;
- (xii) details of surfaces and bearing strengths of runways, taxiways and aprons;
- (xiii) the system of the management of air traffic in the airspace associated with the aerodrome, including procedures for the coordination of traffic with adjacent aerodromes, except any such information or procedures already published in any manual of air traffic services;
- (xiv) operational procedures for the routine and special inspection of the aerodrome manoeuvring area and aprons;
- (xv) if operations are permitted during periods of low visibility, procedures for the protection of the runways during such periods;
- (xvi) procedures for the safe integration of all aviation activities undertaken at the aerodrome;
- (xvii) procedures for the control of bird hazards;
- (xviii) procedures for the use and inspection of the aerodrome lighting system, if such a system is provided; and
- (xix) the scale of rescue, first aid and fire service facilities, the aerodrome emergency procedures and procedures to be adopted in the event of temporary depletion of the rescue and fire service facilities.

| | | | | |
|-----------|---|--------------------|------------|------------|
| Schedule: | 5 | AIRCRAFT EQUIPMENT | 36 of 1999 | 01/07/1997 |
|-----------|---|--------------------|------------|------------|

Remarks:

Adaptation amendments retroactively made - see 36 of 1999 s. 3

Articles 11(4) and 13(2)

1. Every aircraft of a description specified in the first column of the Table set forth in paragraph 4 of this Schedule and which is registered in Hong Kong shall be provided, when flying in the circumstances specified in the second column of the said Table, with adequate equipment, and for the purpose of this paragraph the expression "adequate equipment" shall mean the scales of equipment respectively indicated in that Table:

Provided that, if the aircraft is flying in a combination of such circumstances, the scales of equipment shall not on that account be required to be duplicated.

2. The equipment carried in an aircraft as being necessary for the airworthiness of the aircraft shall be taken into account in determining whether this Schedule is complied with in respect of that aircraft.

3. The following items of equipment shall not be required to be of a type approved by the Chief Executive: (36 of 1999 s. 3)

- (a) The equipment referred to in Scale A(ii).
- (b) First aid equipment and handbook, referred to in Scale A.
- (c) Time-pieces, referred to in Scale F.
- (d) Torches, referred to in Scales G, H, K and Z.
- (e) Whistles, referred to in Scale H.
- (f) Sea anchors, referred to in Scales J and K.
- (g) Rocket signals, referred to in Scale J.
- (h) Equipment for mooring, anchoring or manoeuvring aircraft on the water, referred to in Scale J.
- (i) Paddles, referred to in Scale K.
- (j) Food and water, referred to in Scales K, U and V.

- (k) First aid equipment, referred to in Scales K, U and V.
- (l) Stoves, cooking utensils, snow shovels, ice saws, sleeping bags and Arctic suits, referred to in Scale V.
- (m) Megaphones, referred to in Scale Y1 and Y2.

4.

TABLE

| Description of Aircraft | Circumstances of Flight | Scale of Equipment Required |
|-------------------------|---|---|
| (1) Gliders | (a) flying for purposes other than public transport or aerial work: and when flying by night; | A(ii) |
| | (b) flying for the purpose of public transport or aerial work: and (i) when flying by night (ii) when carrying out aerobatic manoeuvres | A, B(i) and (ii), D and F(i) C and G B(iii) |
| (2) Aeroplanes | (a) flying for purposes other than public transport; and (i) when flying by night (ii) when flying under Instrument Flight Rules (aa) outside controlled airspace (bb) within controlled airspace | A(i) and (ii) and B(i) C and D D E with E(iv) duplicated and F |
| | (iii) when carrying out aerobatic manoeuvres | B(iii) |
| | (b) flying for the purpose of public transport; and (i) when flying under Instrument Flight Rules except flights outside controlled airspace by aeroplanes having a maximum total weight authorized not exceeding 1150 kg. | A, B(i) and (ii), D and F(i) E with E(iv) duplicated and F |
| | (ii) when flying by night; and in the case of aeroplanes of which the maximum total weight authorized exceeds 1150 kg. | C and G, E with E(iv) duplicated and F |
| | (iii) when flying over water beyond gliding distance from land | H |
| | (iv) on all flights on which in the event of any emergency occurring during the take-off or during the landing at the intended destination or any likely alternate destination it is reasonably | |

possible that the aeroplane
would be

forced to land onto water H

(v) when flying over water:

(aa) in the case of an
aeroplane:

(aaa) classified in its
certificate of
airworthiness
as being of
performance
group A, C or
X; or

(bbb) having no
performance
group
classification
in its
certificate of
airworthiness
and of such a
weight and
performance
that with any
one of its
power units
inoperative
and the
remaining
power unit or
units operating
within the
maximum
continuous
power
conditions
specified in
the certificate
of
airworthiness,
performance
schedule or
flight manual
relating to the
aeroplane
issued or
rendered valid
by the Chief
Executive it is
capable of a
gradient of
climb of at
least 1 in 200
at an altitude
of 5000 ft in

- the
International
Standard
Atmosphere
specified in or
ascertainable
by reference to
the certificate
of
airworthiness
in force in
respect of that
aircraft, when
either more
than 400
nautical miles
or more than
90 minutes
flying time*
from the
nearest
aerodrome at
which an
emergency
landing can be
made. (36 of
1993 s. 3) H and K
- (bb) in the case of all
other aeroplanes,
when more than 30
minutes flying time*
from
such an aerodrome. H and K
- (vi) on all flights which involve
manoeuvres on water. H, J and K
- (vii) when flying at a height of
10000 ft or more above
mean sea level:
- (aa) having a certificate of
airworthiness first
issued (whether in
Hong Kong or
elsewhere) before 1
January 1989. L1 or L2
- (bb) having a certificate of
airworthiness first
issued (whether in
Hong Kong or
elsewhere) on or after
1 January 1989. L2
- (viii) on flights when the weather
reports or forecasts
available at the aerodrome
at the time of departure
indicate that conditions

- favouring ice formation are likely to be met. M
- (ix) when carrying out aerobatic manoeuvres. B(iii)
- (x) on all flights on which the aircraft carries a flight crew of more than one person. N
- (xi) on all flights for the purpose of the public transport of passengers. Q and Y2(i), (ii) and (iii)
- (xii) on all flights by a pressurised aircraft. R2
- (xiii) when flying over substantially uninhabited land areas where, in the event of an emergency landing, tropical conditions are likely to be met. U
- (xiv) when flying over substantially uninhabited land or other areas where, in the event of any emergency landing, polar conditions are likely to be met. V
- (xv) when flying at an altitude of more than 49000 ft. W

(3) Turbine-jet aeroplanes having a maximum total weight authorized exceeding 5700 kg or pressurised aircraft having a maximum total weight authorized exceeding 11400 kg.

when flying for the purpose of public transport. O

(4) Turbine-engined aeroplanes having a maximum total weight authorized exceeding 5700 kg and piston-engined aeroplanes having a maximum total weight authorized exceeding 27000 kg

- (a) which are operated by an air transport undertaking under a certificate of airworthiness in the Transport Category (Passenger) or the Transport Category (Cargo); or
- (b) in respect of which application has been made and not withdrawn or refused for such a certificate, and which fly under the "A Conditions" or under a certificate of airworthiness in the Special Category:

when flying on any flight P

Provided that this paragraph shall not apply to aeroplanes falling

when flying on any flight P

within paragraphs (5) or (6) hereof.

(5) Aeroplanes in respect of which there is in force a certificate of airworthiness in the Transport Category (Passenger) or Transport Category (Cargo) and aeroplanes in respect of which application has been made, and not withdrawn or refused, for such a certificate of airworthiness and which fly under the "A Conditions" or in respect of which there is in force a certificate of airworthiness in the Special Category:

- | | | |
|--|---------------------------|--------|
| (a) which conform to a type first issued with a type certificate (whether in Hong Kong or elsewhere) on or after 1 April 1971 and which have a maximum total weight authorized exceeding 5700 kg but not exceeding 11400 kg; or | when flying on any flight | S(i) |
| (b) which conform to a type first issued with a type certificate (whether in Hong Kong or elsewhere) on or after 1 April 1971 and which have a maximum total weight authorized exceeding 11400 kg but not exceeding 27000 kg; or | when flying on any flight | S(ii) |
| (c) which conform to a type first issued with a type certificate (whether in Hong Kong or elsewhere) on or after 1 April 1971 and which have a maximum total weight authorized exceeding 27000 kg but not exceeding 230000 kg; or | when flying on any flight | S(iii) |
| (d) which conform to a type first issued with a type certificate in Hong Kong on or after 1 January 1970 and which have a maximum total weight authorized exceeding 230000 kg; | when flying on any flight | S(iii) |

Provided that this paragraph shall not apply to aeroplanes falling within paragraph (6) hereof.

(6) Aeroplanes in respect of which there is in force a certificate of airworthiness in the Transport Category (Passenger) or Transport

Category (Cargo) and aeroplanes in respect of which application has been made, and not withdrawn or refused, for such a certificate of airworthiness and which fly under "A Conditions" or in respect of which there is in force a certificate of airworthiness in the Special Category:

(a) for which an individual certificate of airworthiness was first issued (whether in Hong Kong or elsewhere) on or after 1 June 1990 and which have a maximum total weight authorized not exceeding 5700 kg, are powered by 2 or more turbine engines and are certified to carry more than 9 passengers; or when flying on any flight S(iv)

(b) for which an individual certificate of airworthiness was first issued (whether in Hong Kong or elsewhere) on or after 1 June 1990 and which have a maximum total weight authorized exceeding 5700 kg, but not exceeding 27000 kg; or when flying on any flight S(v)

(c) for which an individual certificate of airworthiness was first issued (whether in Hong Kong or elsewhere) on or after 1 June 1990 and which have a maximum total weight authorized exceeding 27000 kg when flying on any flight S(vi)

(7) Aeroplanes in respect of which there is in force a certificate of airworthiness in the Aerial Work or Private Category and for which an individual certificate of airworthiness was first issued (whether in Hong Kong or elsewhere) on or after 1 June 1990 and which have a maximum total weight authorized exceeding 27000 kg. when flying on any flight S(vi)

(8) Aeroplanes:
 (a) which conform to a type first issued with a type certificate (whether in Hong Kong or elsewhere) on or after 1 April 1971 and having a maximum

- total weight authorized exceeding 27000 kg and in respect of which there is in force a certificate of airworthiness in the Transport Category (Passenger) or the Transport Category (Cargo); or
- (b) which conform to a type first issued with a type certificate in Hong Kong on or after 1 January 1970 and which have a maximum total weight authorized exceeding 230000 kg and in respect of which there is in force such a certificate of airworthiness; or
- (c) having a maximum total weight authorized exceeding 27000 kg which conform to a type first issued with a type certificate on or after 1 April 1971 (or 1 January 1970 in the case of an aeroplane having a maximum total weight authorized exceeding 230000 kg) in respect of which an application has been made, and not withdrawn or refused for such a certificate of airworthiness and which fly under the "A Conditions" or in respect of which there is in force a certificate of airworthiness in the Special Category.
- (9) Aeroplanes which have a maximum total weight authorized exceeding 15000 kg or which in accordance with the certificate of airworthiness in force in respect thereof may carry more than 30 passengers.
- (10) Aeroplanes:
- (a) which are turbo-jets and which have a maximum total weight authorized exceeding 22700 kg; or
- (b) having a maximum total weight authorized exceeding 5700 kg and which conform to a type for which a certificate of airworthiness was first applied for (whether in Hong Kong or elsewhere) after 30
- when flying on any flight
- when flying on any flight
- when flying on any flight
- when flying on any flight
- on all flights for the purpose of public transport.
- when flying by night for the purpose of the public transport of passengers.
- T
- T
- T
- T
- X
- Z(i) and (ii)

| | | |
|-----|--|---------------|
| | | |
| (c) | <p>April 1972 but not including any aeroplane which in the opinion of the Chief Executive is identical in all matters affecting the provision of emergency evacuation facilities to an aeroplane for which a certificate of airworthiness was first applied for before that date; or (36 of 1999 s. 3)</p> <p>when flying by night for the purpose of the public transport of passengers</p> | Z(i) and (ii) |
| (d) | <p>which in accordance with the certificate of airworthiness in force in respect thereof may carry more than 19 passengers; or</p> <p>having a maximum total weight authorized exceeding 5700 kg and which conform to a type for which a certificate of airworthiness was first applied for (whether in Hong Kong or elsewhere) after 30 April 1972 but not including any aeroplane which in the opinion of the Chief Executive is identical in all matters affecting the provision of emergency evacuation facilities to an aeroplane for which a certificate of airworthiness was first applied for before that date; or (36 of 1999 s. 3)</p> <p>when flying by night for the purpose of the public transport of passengers</p> | Z(i) |
| (e) | <p>which are turbo-jets and which have a maximum total weight authorized exceeding 22700 kg; or</p> <p>when flying for the purpose of the public transport of passengers</p> | Z(iii) |
| (f) | <p>first issued with a type certificate (whether in Hong Kong or elsewhere) on or after 1 January 1958 and which in accordance with the certificate of airworthiness in force in respect thereof may carry more than 19 passengers.</p> <p>when flying for the purpose of the public transport of passengers</p> | Z(iii) |
| (a) | <p>(11) Aeroplanes:</p> <p>powered by one or more turbine jets and first issued with a certificate of airworthiness in Hong Kong on or after 1 April 1989;</p> <p>when flying on any flight</p> | Z(iii) |
| (b) | <p>powered by one or more turbine jets and first issued with a certificate of</p> | AA |

| | | |
|---|---|---|
| <p>airworthiness in Hong Kong prior to 1 April 1989;</p> <p>(c) powered by one or more turbine propeller engines and having a maximum total weight authorized exceeding 5700 kg and first issued with a certificate of airworthiness in Hong Kong on or after 1 April 1989.</p> | <p>when flying on any flight</p> <p>when flying on any flight</p> | <p>AA</p> <p>AA</p> |
| <p>(12) Aeroplanes:</p> | | |
| <p>(a) which conform to a type first issued with a type certificate (whether in Hong Kong or elsewhere) on or after 1 April 1978 and in respect of which there is in force a certificate of airworthiness in the Transport Category (Passenger);</p> | <p>on all flights for the purpose of the public transport of passengers</p> | <p>Y2(iv)</p> |
| <p>(b) which conform to a type first issued with a type certificate (whether in Hong Kong or elsewhere) on or after 1 April 1968 and before 1 April 1978 and in respect of which there is in force a certificate of airworthiness in the Transport Category (Passenger);</p> | <p>on all flights for the purpose of the public transport of passengers</p> | <p>Y2(iv)</p> |
| <p>(c) which conform to a type first issued with a type certificate (whether in Hong Kong or elsewhere) before 1 April 1968 and in respect of which there is in force a certificate of airworthiness in the Transport Category (Passenger).</p> | <p>on all flights for the purpose of the public transport of passengers</p> | <p>Y2(iv)</p> |
| <p>(13) Helicopters and Gyroplanes</p> | <p>(a) flying for purposes other than public transport:</p> | <p>A(i) and (ii) and B(i)</p> |
| | <p>and</p> | |
| | <p>(i) when flying by day under Visual Flight Rules with visual ground reference</p> | <p>D</p> |
| | <p>(ii) when flying by day under instrument Flight Rules or without visual ground reference</p> | |
| | <p>(aa) outside controlled airspace</p> | <p>E with E(ii) duplicated</p> |
| | <p>(bb) within controlled airspace</p> | <p>E with E(ii) and E(iv) duplicated and F with F(iv) for all weights</p> |
| | <p>(iii) when flying by night</p> | |
| | <p>(aa) with visual ground reference</p> | <p>C, E, G(iii) and G(v)</p> |

- (bb) without visual ground reference
 - (aaa) outside controlled airspace C, E, with E(ii) duplicated, G(iii) and G(v)
 - (bbb) within controlled airspace C, E with both E(ii) and E(iv) duplicated, F with F(iv) for all weights, G(iii) and G(v)
- (b) flying for the purpose of public transport; and
 - (i) when flying by day under Visual Flight Rules with visual ground reference D
 - (ii) when flying by day under Instrument Flight Rules or without visual ground reference E with both E(ii) and E(iv) duplicated, F(ii), F(iii) and F(v)
 - (iii) when flying by night with visual ground reference
 - (aa) in the case of a helicopter or gyroplane having a maximum total weight authorized not exceeding 2000 kg C, E and G
 - (bb) in the case of a helicopter or gyroplane having a maximum total weight authorized exceeding 2000 kg C, E with E(ii) duplicated and either E(iv) duplicated or a radio altimeter, F(ii), F(iii), F(v) and G
 - (iv) when flying by night without visual ground reference C, E with both E(ii) and E(iv) duplicated, F(ii), F(iii), F(v) and G
 - (v) when flying over water
 - (aa) in the case of a helicopter or gyroplane classified in its certificate of airworthiness as being of performance group A2 or B when beyond auto-rotational gliding distance from land suitable for an emergency landing E and H
 - (bb) on all flights on which in the event of

- any emergency occurring during the take-off or during the landing at the intended destination or any likely alternate destination it is reasonably possible that the helicopter or gyroplane would be forced to land onto water
- (cc) in the case of a helicopter or gyroplane classified in its certificate of airworthiness as being of performance group A2 when beyond 10 minutes flying time* from land
- (dd) for more than a total of 3 minutes in any flight
- (ee) in the case of a helicopter or gyroplane classified in its certificate of airworthiness as being of performance group A2 which is intended to fly beyond 10 minutes flying time from land, on a flight in support of or in connection with the offshore exploitation, or exploration of mineral resources (including gas) when the weather report or forecasts available to the commander of the aircraft indicate that the sea temperature will be less than plus 10°C during the flight or when any part of the flight is at night
- (vi) on all flights which involve manoeuvres on water
- H
- E, H, K and T
- EE
- I
- H, J and K

- (vii) when flying at a height of 10000 ft or more above mean sea level:
 - (aa) having a certificate of airworthiness first issued (whether in Hong Kong or elsewhere) before 1 January 1989 L1 or L2
 - (bb) having a certificate of airworthiness first issued (whether in Hong Kong or elsewhere) on or after 1 January 1989 L2
- (viii) on flights when the weather reports or forecasts available at the aerodrome at the time of departure indicate that conditions favouring ice formation are likely to be met M
- (ix) on all flights on which the aircraft carries a flight crew of more than one person N
- (x) on all flights for the purpose of the public transport of passengers Y2(i), (ii) and (iii)
- (xi) when flying over substantially uninhabited land areas where, in the event of an emergency landing, tropical conditions are likely to be met U
- (xii) when flying over substantially uninhabited land or other areas where, in the event of any emergency landing, polar conditions are likely to be met V

(14) Helicopters & Gyroplanes

- (a) having a maximum total weight authorized exceeding 5700 kg and which conform to a type for which a certificate of airworthiness was first applied for (whether in Hong Kong or elsewhere) after 30 April 1972 but not including any helicopter or gyroplane which in the opinion of the Chief Executive is identical in all matters affecting the

| | | |
|---|--|-----------------|
| provision of emergency evacuation facilities to a helicopter or gyroplane for which a certificate of airworthiness was first applied for before that date; or (36 of 1999 s. 3) | when flying by night for the purpose of the public transport of passengers | Z(i) and (ii) |
| (b) which, in accordance with the certificate of airworthiness in force in respect thereof may carry more than 19 passengers; or | when flying by night for the purpose of the public transport of passengers | Z(i) |
| (c) which have a certificate of airworthiness issued in the Transport Category (Passenger or Cargo) and which have either a maximum total weight authorized exceeding 2730 kg or which may carry more than 9 passengers; or | when flying on any flight | S(vii) |
| (d) which have a certificate of airworthiness issued in the Transport Category (Passenger or Cargo) and helicopters and gyroplanes in respect of which application has been made and not withdrawn or refused for such a certificate of airworthiness and which fly under the "A Conditions" or which have a certificate of airworthiness in the Special Category and | | |
| (i) which have a maximum total weight authorized exceeding 2730 kg but not exceeding 7000 kg or which in accordance with the certificate of airworthiness in force in respect thereof may carry more than 9 passengers, or both | when flying on any flight | SS(i) or (iii) |
| (ii) which have a maximum total weight authorized exceeding 7000 kg | when flying on any flight | SS(ii) or (iii) |

* For the purposes of this Table, flying time shall be calculated on the assumption that the aircraft is flying in still air at the speed specified in the relevant certificate of airworthiness as the speed for compliance with regulations governing flights over water.

5. The scales of equipment indicated in the foregoing Table shall be as follows:

Scale A

- (i) Spare fuses for all electrical circuits the fuses of which can be replaced in flight, consisting of 10 per cent of the number of each rating or three of each rating, whichever is the greater.
- (ii) Maps, charts, codes and other documents and navigational equipment necessary, in addition to any other equipment required under this Order, for the intended flight of the aircraft including any diversion which may reasonably be expected.
- (iii) First aid equipment of good quality, sufficient in quantity, having regard to the number of persons on board the aircraft, and including the following:
 - Roller bandages, triangular bandages, adhesive plaster, absorbent gauze, cotton wool (or wound dressings in place of the absorbent gauze and cotton wool), burn dressings, safety pins; Haemostatic bandages or tourniquets, scissors;
 - Antiseptic, analgesic and stimulant drugs;
 - Splints, in the case of aeroplanes the maximum total weight authorized of which exceeds 5700 kg;
 - A handbook on first aid.
- (iv) In the case of a flying machine used for the public transport of passengers in which, while the flying machine is at rest on the ground, the sill of any external door intended for the disembarkation of passengers, whether normally or in an emergency:
 - (a) is more than 1.82 metres from the ground when the undercarriage of the machine is in the normal position for taxiing; or
 - (b) would be more than 1.82 metres from the ground if the undercarriage or any part thereof should collapse, break or fail to function;apparatus readily available for use at each door consisting of a device or devices which will enable passengers to reach the ground safely in an emergency while the flying machine is on the ground, and can be readily fixed in position for use.

Scale AA

An altitude alerting system capable of alerting the pilot upon approaching a preselected altitude in either ascent or descent, by a sequence of visual and aural signals in sufficient time to establish level flight at that preselected altitude, and when deviating above or below that preselected altitude, by a visual and an aural signal:

Provided that if the system becomes unserviceable, the aircraft may fly or continue to fly, until it first lands at a place at which it is reasonably practicable for the system to be repaired or replaced.

Scale B

- (i) (a) If the maximum total weight authorized of the aircraft is 2730 kg or less, for every pilot's seat and for any seat situated alongside a pilot's seat, a safety belt with one diagonal shoulder strap or a safety harness:
 - Provided that the Chief Executive may permit a safety belt without a diagonal shoulder strap to be fitted if he is satisfied that it is not reasonably practicable to fit a safety belt with one diagonal shoulder strap or a safety harness. (36 of 1999 s. 3)
- (b) If the maximum total weight authorized of the aircraft exceeds 2730 kg, a safety harness for every pilot's seat and for any seat situated alongside a pilot's seat, in place of the safety belt with one diagonal shoulder strap referred to under sub-paragraph (a):
 - Provided that the Chief Executive may permit a safety belt with one diagonal shoulder strap to be fitted if he is satisfied that it is not reasonably practicable to fit a safety harness. (36 of 1999 s. 3)
- (c) For every seat in use (not being a seat referred to in sub-paragraphs (a), (b), (e) and (f)) a safety belt with or without one diagonal shoulder strap or a safety harness.
- (d) In addition and to be attached to or secured by the equipment required in sub-paragraph (c) above, a child restraint device for every child under the age of 2 years on board.

- (e) On all flights for the public transport of passengers by aircraft, for each seat for use by cabin attendants who are required to be carried under this Order, a safety harness.
- (f) On all flights in aeroplanes the maximum total weight authorized of which does not exceed 5700 kg which in accordance with the certificate of airworthiness in force thereof is not capable of seating more than 9 passengers (otherwise than in seats referred to under sub-paragraphs (a) and (b)), a safety belt with one diagonal shoulder strap or a safety harness for each seat intended for use by a passenger:

Provided that the provisions of this sub-paragraph shall not apply to aeroplanes in respect of which a certificate of airworthiness was first issued (whether in Hong Kong or elsewhere) before 1 February 1989.

- (ii) If the commander cannot, from his own seat, see all the passengers' seats in the aircraft, a means of indicating to the passengers that seat belts should be fastened.
- (iii) A safety harness for every seat in use:

Provided that in the case of an aircraft carrying out aerobatic manoeuvres consisting only of erect spinning, the Chief Executive may permit a safety belt with one diagonal shoulder strap to be fitted if he is satisfied that such restraint is sufficient for the carrying out of erect spinning in that aircraft and that it is not reasonably practicable to fit a safety harness in that aircraft. (36 of 1999 s. 3)

Scale C

- (i) Equipment for displaying the lights required by the Rules of the Air;
- (ii) Electrical equipment, supplied from the main source of supply in the aircraft, to provide sufficient illumination to enable the flight crew properly to carry out their duties during flight;
- (iii) Unless the aircraft is equipped with radio, devices for making the visual signal specified in the Rules of the Air as indicating a request for permission to land.

Scale D

- (i) (a) In the case of a helicopter or gyroplane, a slip indicator;
- (b) In the case of any other flying machine either:
 - (aa) a turn indicator and a slip indicator; or
 - (bb) a gyroscopic bank and pitch indicator and a gyroscopic direction indicator;
- (ii) A sensitive pressure altimeter adjustable for any sea level barometric pressure which the weather report or forecasts available to the commander of the aircraft indicate is likely to be encountered during the intended flight.

Scale E

- (i) (a) In the case of a helicopter or gyroplane, a slip indicator;
- (b) In the case of any other flying machine, a turn indicator and a slip indicator;
- (ii) A gyroscopic bank and pitch indicator;
- (iii) A gyroscopic direction indicator;
- (iv) A sensitive pressure altimeter adjustable for any sea level barometric pressure which the weather report or forecasts available to the commander of the aircraft indicate is likely to be encountered during the intended flight:

Provided that any aircraft may, at the option of the operator, be equipped with an additional gyroscopic bank and pitch indicator in lieu of the turn indicator referred to in (i) of this Scale.

Scale EE

A radio altimeter with an audio voice warning operating below a preset height and a visual warning capable of operating at a height selectable by the pilot.

Scale F

- (i) A timepiece indicating the time in hours, minutes and seconds;
- (ii) A means of indicating whether the power supply to the gyroscopic instrument is adequate;
- (iii) A rate of climb and descent indicator;
- (iv) If the maximum total weight authorized of the aircraft exceeds 5700 kg a means of indicating outside air temperature;
- (v) If the maximum total weight authorized of the aircraft exceeds 5700 kg two air speed indicators.

Scale G

- (i) In the case of an aircraft other than a helicopter or gyroplane landing lights consisting of two single filament lamps, or one dual filament lamp with separately energised filaments;
- (ii) An electrical lighting system to provide illumination in every passenger compartment;
- (iii) (a) One electric torch for each member of the crew of the aircraft; or
(b) (aa) one electric torch for each member of the flight crew of the aircraft; and
(bb) at least one electric torch affixed adjacent to each floor level exit intended for the disembarkation of passengers whether normally or in an emergency, provided that such torches shall:
 - (aaa) be readily accessible for use by the crew of the aircraft at all times; and
 - (bbb) number in total not less than the minimum number of cabin attendants required to be carried with a full passenger complement;
- (iv) In the case of an aircraft other than a helicopter or gyroplane of which the maximum total weight authorized exceeds 5700 kg, means of observing the existence and build up of ice on the aircraft;
- (v) (a) In the case of a helicopter or gyroplane in respect of which there is in force a certificate of airworthiness designating the helicopter or gyroplane as being of performance group A, either:
 - (aa) two landing lights both of which are adjustable so as to illuminate the ground in front of and below the helicopter or gyroplane and one of which is adjustable so as to illuminate the ground on either side of the helicopter or gyroplane; or
 - (bb) one landing light or, if the maximum total weight authorized of the helicopter or gyroplane exceeds 5700 kg, one dual filament landing light with separately energised filaments, or two single filament lights, each of which is adjustable so as to illuminate the ground in front of and below the helicopter or gyroplane, and two parachute flares;
- (b) In the case of a helicopter or gyroplane in respect of which there is in force a certificate of airworthiness designating the helicopter or gyroplane as being of performance group B, either:
 - (aa) one landing light and 2 parachute flares; or
 - (bb) if the maximum total weight authorized of the helicopter or gyroplane exceeds 5700 kg, either one dual filament landing light with separately energised filaments or 2 single filament landing lights, and 2 parachute flares.

Scale H

For each person on board, a lifejacket equipped with a whistle and waterproof torch:
Provided that lifejackets constructed and carried solely for use by children under three years of age need not be equipped with a whistle.

Scale I

A survival suit for each member of the crew.

Scale J

- (i) Additional flotation equipment, capable of supporting one-fifth of the number of persons on board, and provided in a place of stowage accessible from outside the flying machine;
- (ii) Parachute distress rocket signals capable of making, from the surface of the water, the pyrotechnical signal of distress specified in the Rules of the Air and complying with Part I of Schedule 8 to the Merchant Shipping (Safety) (Life-Saving Appliances) (Ships Built on or after 1 July 1986) Regulations 1991, made under the Merchant Shipping (Safety) Ordinance (Cap 369);
- (iii) A sea anchor and other equipment necessary to facilitate mooring, anchoring or manoeuvring the flying machine on water, appropriate to its size, weight and handling characteristics.

Scale K

- (i) (a) In the case of a flying machine, other than a helicopter or gyroplane carrying 20 or more persons, liferafts sufficient to accommodate all persons on board;
- (b) In the case of a helicopter or gyroplane carrying 20 or more persons, a minimum of 2 liferafts sufficient together to accommodate all persons on board.

Each liferaft shall contain the following equipment:

- (a) means for maintaining buoyancy;
- (b) a sea anchor;
- (c) life-lines, and means of attaching one liferaft to another;
- (d) paddles or other means of propulsion;
- (e) means of protecting the occupants from the elements;
- (f) a waterproof torch;
- (g) marine type pyrotechnical distress signals;
- (h) means of making sea water drinkable, unless the full quantity of fresh water is carried as specified in sub-paragraph (i);
- (i) for each 4 or proportion of 4 persons the liferaft is designed to carry:
100 grammes of glucose toffee tablets;
1/2 litre of fresh water in durable containers:

Provided that in any case in which it is not reasonably practicable to carry the quantity of water above specified as large a quantity of fresh water as is reasonably practicable in the circumstances may be substituted. In no case however shall the quantity of water carried be less than is sufficient, when added to the amount of fresh water capable of being produced by means of the equipment specified in sub-paragraph (h) to provide 1/2 litre of water for each 4 or proportion of 4 persons the liferaft is designed to carry.

- (j) first aid equipment;

Items (f) to (j) inclusive shall be contained in a pack.

- (ii) The number of survival beacon radio apparatus carried when the aircraft is carrying the number of liferafts specified in column 1 of the following Table shall be not less than the number specified in, or calculated in accordance with column 2.

TABLE

| Column 1 | Column 2 |
|--|---|
| Not more than 8 liferafts. | 2 survival beacon radio apparatus. |
| For every additional 4 or proportion of 4 liferafts. | 1 additional survival beacon radio apparatus. |

- (iii) In the case of a helicopter or gyroplane, an emergency beacon which is automatically deployed and activated in the event of a crash.

Scale L1

Part I

- (i) In every flying machine which is provided with means for maintaining a pressure greater than 700 millibars throughout the flight in the flight crew compartment and in the compartments in which the passengers are carried:
- (a) a supply of oxygen sufficient, in the event of failure to maintain such pressure, occurring in the circumstances specified in columns 1 and 2 of the Table set out in Part II of this Scale, for continuous use, during the periods specified in column 3 of the said Table, by the persons for whom oxygen is to be provided in accordance with column 4 of that Table; and
 - (b) in addition, in every case where the flying machine flies above flight level 350, a supply of oxygen in a portable container sufficient for the simultaneous first aid treatment of 2 passengers, together with suitable and sufficient apparatus to enable such persons to use the oxygen.
- (ii) In any other flying machine:
- (a) a supply of oxygen sufficient for continuous use by all the crew other than the flight crew, and if passengers are carried, by 10% of the number of passengers, for any period exceeding 30 minutes during which the flying machine flies above flight level 100 but not above flight level 130 and the flight crew shall be supplied with oxygen sufficient for continuous use for any period during which the flying machine flies above flight level 100; and
 - (b) a supply of oxygen sufficient for continuous use by all persons on board for the whole time during which the flying machine flies above flight level 130, together with suitable and sufficient apparatus to enable such persons to use the oxygen.
- (iii) The quantity of oxygen required for the purpose of complying with paragraphs (i) and (ii) of this Part of this Scale shall be computed in accordance with the information and instructions relating thereto specified in the operations manual relating to the aircraft pursuant to Item (vi) of Part A of Schedule 11 to this Order.

Part II

| Column 1 | Column 2 | Column 3 | Column 4 |
|--|--|--|--|
| Vertical displacement of the flying machine in relation to flight levels | Capability of flying machine to descend (where relevant) | Period of supply of oxygen | Persons for whom oxygen is to be provided |
| Above flight level 100 | - | 30 minutes or the period specified at A hereunder whichever is greater | In addition to any passengers for whom oxygen is provided as specified below, all the crew |
| Above flight level 100 but not above flight | { Flying machine is either flying at or below flight level 150 or is capable of descending and continuing to destination as specified at X | 30 minutes or the period specified at A hereunder whichever is the greater | 10 per cent of number of passengers |
| | | 10 minutes or the | All passengers |

| | | | |
|---|---|---|--|
| level 300 | { hereunder { Flying machine is flying above flight level 150 and is not so capable | { period specified at B hereunder { whichever is the greater { and in addition { 30 minutes or the { period specified at C hereunder { whichever is the greater | { 10 per cent of number { of passengers |
| Above flight level 300 but not above flight level 350 | { Flying machine is capable of descending and continuing to destination as specified at Y hereunder { Flying machine is not so capable | { 30 minutes or the { period specified at A hereunder { whichever is the greater { 10 minutes or the { period specified at B hereunder { whichever is the greater { and in addition { 30 minutes or the { period specified at C hereunder { whichever is the greater { 10 minutes or the { period specified at B hereunder { whichever is the greater | { 15 per cent of number { of passengers { All passengers { 15 per cent of number { of passengers { All passengers |
| Above flight level 350 | - | { and in addition { 30 minutes or the { period specified at C hereunder { whichever is the greater | { 15 per cent of number { of passengers |

A The whole period during which, after a failure to maintain a pressure greater than 700 millibars in the control compartment and in the compartments in which passengers are carried has occurred, the flying machine flies above flight level 100.

- B The whole period during which, after a failure to maintain such pressure has occurred, the flying machine flies above flight level 150.
- C The whole period during which, after a failure to maintain such pressure has occurred, the flying machine flies above flight level 100, but not above flight level 150.
- X The flying machine is capable, at the time when a failure to maintain such pressure occurs, of descending in accordance with the emergency descent procedure specified in the relevant flight manual and without flying below the minimum altitudes for safe flight specified in the operations manual relating to the aircraft, to flight level 150 within 6 minutes, and of continuing at or below that flight level to its place of intended destination or any other place at which a safe landing can be made.
- Y The flying machine is capable, at the time when a failure to maintain such pressure occurs, of descending in accordance with the emergency descent procedure specified in the relevant flight manual and without flying below the minimum altitudes for safe flight specified in the operations manual relating to the aircraft, to flight level 150 within 4 minutes, and of continuing at or below that flight level to its place of intended destination or any other place at which a safe landing can be made.

Scale L2

A supply of oxygen and the associated equipment to meet the requirements set out in Parts I and II of this scale. The duration for the purposes of this scale shall be:

- (i) that calculated in accordance with the operations manual prior to the commencement of the flight, being the period or periods which it is reasonably anticipated that the aircraft will be flown in the circumstances of the intended flight at a height where the said requirements apply and in calculating the said duration account shall be taken of:
 - (a) in the case of pressurised aircraft, the possibility of depressurisation when flying above flight level 100;
 - (b) the possibility of failure of one or more of the aircraft engines;
 - (c) restrictions due to required minimum safe altitude;
 - (d) fuel requirement; and
 - (e) the performance of the aircraft; or
- (ii) the period or periods during which the aircraft is actually flown in the circumstances specified in the said Parts;

whichever is the greater.

Part I

Unpressurised aircraft

- (i) When flying at or below flight level 100:
Nil
- (ii) When flying above flight level 100 but not exceeding flight level 120:

| | Supply for | Duration |
|-----|--|---|
| (a) | Members of the flight crew | Any period during which the aircraft flies above flight level 100. |
| (b) | Cabin attendants and 10 per cent of passengers | For any continuous period exceeding 30 minutes during which the aircraft flies above flight level 100 but not exceeding flight level 120, the duration shall be the period by which 30 minutes is exceeded. |

(iii) When flying above flight level 120:

| | Supply for | Duration |
|-----|-------------------------------------|--|
| (a) | Members of the flight crew | Any period during which the aircraft flies above flight level 120. |
| (b) | Cabin attendants and all passengers | Any period during which the aircraft flies above flight level 120. |

Part II

Pressurised aircraft

- (i) When flying at or below flight level 100-
Nil
- (ii) When flying above flight level 100 but not exceeding flight level 250-

| | Supply for | Duration |
|-----|--|--|
| (a) | Members of the flight crew | 30 minutes or whenever the cabin pressure altitude exceeds 10000 ft, whichever is the greater |
| (b) | Cabin attendants and 10 per cent of passengers | (aa) When the aircraft is capable of descending and continuing to its destination as specified at A hereunder, 30 minutes or whenever the cabin pressure altitude exceeds 10000 ft, whichever is the greater (bb) When the aircraft is not so capable, whenever the cabin pressure altitude is greater than 10000 ft, but does not exceed 12000 ft |
| (c) | Cabin attendants and passengers | (aa) When the aircraft is capable of descending and continuing to its destination as specified at A hereunder, no requirement other than that at (ii)(b)(aa) of this part of this scale (bb) When the aircraft is not so capable and the cabin pressure altitude exceeds 12000 ft, the duration shall be the period when the cabin pressure altitude exceeds 12000 ft or 10 minutes, whichever is the greater |

(iii) When flying above flight level 250-

| | Supply for | Duration |
|-----|----------------------------|--|
| (a) | Members of the flight crew | 2 hours or whenever the cabin pressure altitude exceeds 10000 ft, whichever is the greater |
| (b) | Cabin attendants | Whenever the cabin pressure altitude exceeds 10000 ft, and a portable supply |

- | | | |
|-----|--|---|
| | | for 15 minutes |
| (c) | 10 per cent of passengers | Whenever the cabin pressure altitude exceeds 10000 ft but does not exceed 12000 ft |
| (d) | 30 per cent of passengers | Whenever the cabin pressure altitude exceeds 12000 ft but does not exceed 15000 ft |
| (e) | All passengers | If the cabin pressure altitude exceeds 15000 ft, the duration shall be the period when the cabin pressure altitude exceeds 15000 ft or 10 minutes, whichever is the greater |
| (f) | 2 per cent of passengers or 2 passengers, whichever is the greater, being a supply of first aide oxygen which must be available for simultaneous first aid treatment of 2 per cent or 2 passengers wherever they are seated in the aircraft. | Whenever, after decompression, the cabin pressure altitude exceeds 8000 ft |

A The flying machine is capable, at the time when a failure to maintain cabin pressurisation occurs of descending in accordance with the emergency descent procedure specified in the relevant flight manual and without flying below the minimum altitudes for safe flight specified in the operations manual relating to the aircraft, to flight level 120 within 5 minutes and of continuing at or below that flight level to its place of intended destination or any other place at which a safe landing can be made.

Scale M

Equipment to prevent the impairment through ice formation of the functioning of the controls, means of propulsion, lifting surfaces, windows or equipment of the aircraft so as to endanger the safety of the aircraft.

Scale N

An intercommunication system for use by all members of the flight crew and including microphones, not of a hand-held type, for use by the pilot and flight engineer (if any).

Scale O

A radar set capable of giving warning to the pilot in command of the aircraft and to the co-pilot of the presence of cumulo-nimbus clouds and other potentially hazardous weather conditions:

Provided that a flight may commence if the set is unserviceable or continue if the set becomes unserviceable thereafter:

- (a) so as to give the warning only to one pilot, so long as the aircraft is flying only to the place at which it first becomes reasonably practicable for the set to be repaired; or
- (b) when the weather report or forecasts available to the commander of the aircraft indicate that cumulo-nimbus clouds or other potentially hazardous weather conditions, which can be detected by the set when in working order, are unlikely to be encountered on the intended route or any planned diversion therefrom or the commander has satisfied himself that any such weather conditions will be encountered in daylight and can be seen and avoided, and the aircraft is in either case operated throughout the flight in accordance with any relevant instructions given in the operations manual.

Scale P

A flight data recorder which is capable of recording, by reference to a time-scale, the following data:

- (a) indicated airspeed;
- (b) indicated altitude;
- (c) vertical acceleration;
- (d) magnetic heading;
- (e) pitch attitude, if the equipment provided in the aeroplane is of such a nature as to enable this item to be recorded;
- (f) engine power, if the equipment provided in the aeroplane is of such a nature as to enable this item to be recorded;
- (g) flap position;
- (h) roll attitude, if the equipment provided in the aeroplane is of such a nature as to enable this item to be recorded:

Provided that any aeroplane having a maximum total weight authorized not exceeding 11400 kg may be provided with:

- (i) a flight data recorder capable of recording the data described in sub-paragraphs (a) to (h) of this Scale; or
- (ii) a 4 channel cockpit voice recorder.

In addition, on all flights by turbine-powered aeroplanes having a maximum total weight authorized exceeding 11400 kg, a 4 channel cockpit voice recorder.

The flight data recorder and cockpit voice recorder referred to above shall be so constructed that the record would be likely to be preserved in the event of an accident to the aeroplane:

Provided that an aeroplane shall not be required to carry the said equipment, if before take-off the equipment is found to be unserviceable and the aircraft flies in accordance with arrangements approved by the Chief Executive. (36 of 1999 s. 3)

Scale Q

If the maximum total weight authorized of the aeroplane exceeds 5700 kg and it was first registered, whether in Hong Kong or elsewhere, on or after 1 June 1965, a door between the flight crew compartment and any adjacent compartment to which passengers have access, which door shall be fitted with a lock or bolt capable of being worked from the flight crew compartment.

Scale R1

- (i) Equipment sufficient to protect the eyes, nose and mouth of the pilot in command of the aircraft from the effects of smoke and noxious gases for a period of not less than 15 minutes;
- (ii) Portable equipment sufficient to protect the eyes, nose and mouth of one other member of the crew of the aircraft from the effects of smoke and noxious gases for a period of not less than 8 minutes; and
- (iii) Equipment sufficient to protect from the effects of smoke and noxious gases the eyes of all members of the flight crew of the aircraft whose eyes are not adequately protected by other equipment.

Scale R2

- (i) (a) In respect of aeroplanes having a maximum total weight authorized exceeding 5700 kg, equipment sufficient to protect the eyes, nose and mouth of all members of the flight crew required to be carried by virtue of Article 18 of this Order for a period of not less than 15 minutes and, in addition, where the minimum flight crew required as aforesaid is more than one and a cabin attendant is not required to be carried by virtue of Article 18 of this Order, portable equipment sufficient to protect the eyes,

nose and mouth of one member of the flight crew for a period of not less than 15 minutes;

- (b) In respect of aeroplanes having a maximum total weight authorized not exceeding 5700 kg, the equipment specified in (i)(a) of this Scale:

Provided that in the case of such aeroplanes restricted by virtue of the operator's operations manual to flight at or below flight level 250 and capable of descending as specified at A hereunder such equipment shall be sufficient to protect the eyes only.

- (ii) (a) In respect of aeroplanes having a maximum total weight authorized exceeding 5700 kg, portable equipment to protect the eyes, nose and mouth of all cabin attendants required to be carried by virtue of Article 18 of this Order for a period of not less than 15 minutes;

- (b) In respect of aeroplanes having a maximum total weight authorized not exceeding 5700 kg, the equipment specified in (ii)(a) of this Scale:

Provided that this requirement shall not apply to such aeroplanes restricted by virtue of the operator's operations manual to flight at or below flight level 250 and capable of descending as specified at A hereunder.

- A The aeroplane is capable of descending in accordance with the emergency descent procedure specified in the relevant flight manual and without flying below the minimum altitudes for safe flight specified in the operations manual relating to the aeroplane, to flight level 100 within 4 minutes and of continuing at or below that flight level to its place of intended destination or any other place at which a safe landing can be made.

Scale S

A flight recording system comprising:

- (i) either a 4 channel cockpit voice recorder or a flight data recorder capable of recording by reference to a time scale the data required to determine the following matters accurately in respect of the aeroplane: the flight path, altitude and the basic lift, thrust and drag forces acting upon it;
- (ii) a 4 channel cockpit voice recorder and a flight data recorder capable of recording by reference to a time scale the data required to determine the following matters accurately in respect of the aeroplane the information specified in paragraph (i) of this Scale together with use of VHF transmitters;
- (iii) a 4 channel cockpit voice recorder and a flight data recorder capable of recording by reference to a time scale the data required to determine the following matters accurately in respect of the aeroplane: the flight path, attitude, the basic lift, thrust and drag forces acting upon it, the selection of high lift devices (if any) and airbrakes (if any), the position of primary flying control and pitch trim surfaces, outside air temperature, instrument landing system deviations, use of automatic flight control systems, use of VHF transmitters, radio altitude (if any), the level or availability of essential AC electricity supply and cockpit warnings relating to engine fire and engine shut-down, cabin pressurisation, presence of smoke and hydraulic/ pneumatic power supply;
- (iv) either a cockpit voice recorder and a flight data recorder or a combined cockpit voice recorder/flight data recorder capable in either case of recording by reference to a time scale the data required to determine the following matters accurately in respect of the aeroplane: the flight path, speed, altitude, engine power, outside air temperature, configuration of lift and drag devices, use of VHF transmitters and use of automatic flight control systems;
- (v) a cockpit voice recorder and a flight data recorder capable of recording by reference to a time scale the data required to determine the following matters accurately in respect of the aeroplane: the flight path, speed, altitude, engine power, outside air temperature, configuration of lift and drag devices, use of VHF transmitters and use of automatic flight control systems;

- (vi) a cockpit voice recorder and a flight data recorder capable of recording by reference to a time scale the data required to determine the following matters accurately in respect of the aeroplane: the flight path, speed, altitude, engine power, outside air temperature, instrument landing system deviations, marker beacon passage, radio altitude, configuration of the landing gear and lift and drag devices, position of primary flying control and pitch trim surfaces, use of automatic flight control systems, use of VHF transmitters, ground speed/drift angle or latitude/longitude if the navigational equipment provided in the aeroplane is of such a nature as to enable this information to be recorded with reasonable practicability, cockpit warnings relating to engine fire, engine shut-down, cabin pressurisation, presence of smoke, essential AC electricity supply, hydraulic/pneumatic power supply, ground proximity and stalling;
- (vii) in respect of helicopters having a maximum total weight authorized exceeding 2730 kg or a seating capacity exceeding 9 passengers, a 4 channel cockpit voice recorder which has attached to it an under-water sonar location device.

The cockpit voice recorder or flight data recorder or combined cockpit voice recorder/flight data recorder, as the case may be, shall be so constructed that the record would be likely to be preserved in the event of an accident:

Provided that an aircraft shall not be required to carry the said equipment, if before take-off the equipment is found to be unserviceable and the aircraft flies in accordance with arrangements approved by the Chief Executive. (36 of 1999 s. 3)

Scale SS

- (i) A 4 channel cockpit voice recorder capable of recording and retaining the data recorded during at least the last 30 minutes of its operation and a flight data recorder capable of recording and retaining the data recorded during at least the last 8 hours of its operation being the data required to determine by reference to a time scale the following matters accurately in respect of the helicopter or gyroplane:
 - (a) flight path;
 - (b) speed;
 - (c) altitude;
 - (d) engine power;
 - (e) main rotor speed;
 - (f) outside air temperature;
 - (g) position of pilot's primary flight controls;
 - (h) use of VHF transmitters;
 - (i) use of automatic flight controls (if any);
 - (j) use of stability augmentation system (if any);
 - (k) cockpit warnings relating to the master warning system; and
 - (l) selection of hydraulic system and cockpit warnings of failure of essential hydraulic systems.
- (ii) A 4 channel cockpit voice recorder capable of recording and retaining the data recorded during at least the last 30 minutes of its operation and a flight data recorder capable of recording and retaining the data recorded during at least the last 8 hours of its operation being the data required to determine by reference to a time scale the information specified in paragraph (i) of this Scale together with the following matters accurately in respect of the helicopter or gyroplane:
 - (m) landing gear configuration;
 - (n) indicated sling load force if an indicator is provided in the helicopter or gyroplane of such a nature as to enable this information to be recorded with reasonable practicability;
 - (o) radio altitude;
 - (p) instrument landing system deviations;
 - (q) marker beacon passage;
 - (r) ground speed/drift angle or latitude/longitude if the navigational equipment

provided in the helicopter or gyroplane is of such a nature as to enable this information to be recorded with reasonable practicability; and

- (s) main gear box oil temperature and pressure.
- (iii) (a) A combined cockpit voice recorder/flight data recorder which meets the following requirements:
 - (aa) in the case of a helicopter or gyroplane which is otherwise required to carry a flight data recorder specified at paragraph (i) of this Scale the flight data recorder shall be capable of recording the data specified therein and retaining it for the duration therein specified;
 - (bb) in the case of a helicopter or gyroplane which is otherwise required to carry a flight data recorder specified at paragraph (ii) of this Scale, the flight data recorder shall be capable of recording the data specified therein and retaining it for the duration therein specified;
 - (cc) the cockpit voice recorder shall be capable of recording and retaining at least the last hour of cockpit voice recording information on not less than three separate channels.
- (b) In any case when a combined cockpit voice recorder/flight data recorder specified at paragraph (iii)(a) of this Scale is required to be carried by or under this Order, the flight data recorder shall be capable of retaining as protected data the data recorded during at least the last 5 hours of its operation or the maximum duration of the flight, whichever is the greater. It shall also be capable of retaining additional data as unprotected data for a period which together with the period for which protected data is required to be retained amounts to a total of 8 hours:

Provided that the flight data recorder need not be capable of retaining the said additional data if additional data is retained which relates to the period immediately preceding the period to which the required protected data relates or for such other period or periods that the Chief Executive may permit pursuant to Article 37 of this Order and the additional data is retained in accordance with arrangements approved by the Chief Executive. (36 of 1999 s. 3)

With the exception of flight data which it is expressly stated above may be unprotected, the cockpit voice recorder, flight data recorder or combined cockpit voice recorder and flight data recorder, as the case may be, shall be so constructed and installed that the record (herein referred to as "protected data") would be likely to be preserved in the event of an accident and each cockpit voice recorder, flight data recorder or combined cockpit voice recorder/flight data recorder required to be carried on the helicopter or gyroplane shall have attached an automatically activated underwater sonar location device or an emergency locator radio transmitter as appropriate:

Provided that a helicopter or gyroplane shall not be required to carry the said equipment if, before take-off, the equipment is found to be unserviceable and the aircraft flies in accordance with arrangements approved by the Chief Executive. (36 of 1999 s. 3)

Scale T

An underwater sonar location device except in respect of those helicopters or gyroplanes which have a device attached to a cockpit voice recorder in accordance with Scale S or are required to carry equipment in accordance with Scale SS.

Scale U

- (a) 1 survival beacon radio apparatus;
- (b) marine type pyrotechnical distress signals;
- (c) for each 4 or proportion of 4 persons on board, 100 grammes of glucose toffee tablets;
- (d) for each 4 or proportion of 4 persons on board, 1/2 litre of fresh water in durable containers;

- (e) first aid equipment.

Scale V

- (a) 1 survival beacon radio apparatus;
- (b) marine type pyrotechnical distress signals;
- (c) for each 4 or proportion of 4 persons on board, 100 grammes of glucose toffee tablets;
- (d) for each 4 or proportion of 4 persons on board, 1/2 litre of fresh water in durable containers;
- (e) first aid equipment;
- (f) for every 75 or proportion of 75 persons on board, 1 stove suitable for use with aircraft fuel;
- (g) 1 cooking utensil, in which snow or ice can be melted;
- (h) 2 snow shovels;
- (i) 2 ice saws;
- (j) single or multiple sleeping-bags, sufficient for the use of one-third of all persons on board;
- (k) 1 Arctic suit for each member of the crew of the aircraft.

Scale W

Cosmic radiation detection equipment calibrated in millirems per hour and capable of indicating the action and alert levels of radiation does rate:

Provided that an aircraft shall not be required to carry the said equipment if before take-off the equipment is found to be unserviceable and it is not reasonably practicable to repair or replace it at the aerodrome of departure and the radiation forecast available to the commander of the aircraft indicates that hazardous radiation conditions are unlikely to be encountered by the aircraft on its intended route or any planned diversion therefrom.

Scale X

Equipment capable of giving warning to the pilot of the potentially hazardous proximity of ground or water:

Provided that if the equipment becomes unserviceable, the aircraft may fly or continue to fly until it first lands at a place at which it is reasonably practicable for the equipment to be repaired or replaced.

Scale Y1

- (i) If the aircraft has a total seating capacity of not less than 60 and not exceeding 149 passengers, one portable battery-powered megaphone capable of conveying instructions to all persons in the passenger compartment and readily available for use by a member of the crew.
- (ii) If the aircraft has a total seating capacity exceeding 149 passengers, 2 portable battery-powered megaphones together capable of conveying instructions to all persons in the passenger compartments and readily available for use by a member of the crew.

Scale Y2

- (i) If the aircraft may in accordance with its certificate of airworthiness carry more than 19 and less than 100 passengers, one portable battery-powered megaphone capable of conveying instructions to all persons in the passenger compartment and readily available for use by a member of the crew.
- (ii) If the aircraft may in accordance with its certificate of airworthiness carry more than 99

and less than 200 passengers, 2 portable battery-powered megaphones together capable of conveying instructions to all persons in the passenger compartment and each readily available for use by a member of the crew.

- (iii) If the aircraft may in accordance with its certificate of airworthiness carry more than 199 passengers, 3 portable battery-powered megaphones together capable of conveying instructions to all persons in the passenger compartment and each readily available for use by a member of the crew.
- (iv) If the aircraft may in accordance with its certificate of airworthiness carry more than 19 passengers:
 - (a) a public address system; and
 - (b) an interphone system of communication between members of the flight crew and the cabin attendants.

Scale Z

- (i) An emergency lighting system to provide illumination in the passenger compartment sufficient to facilitate the evacuation of the aircraft notwithstanding the failure of the lighting systems specified in paragraph (ii) of Scale G.
- (ii) An emergency lighting system to provide illumination outside the aircraft sufficient to facilitate the evacuation of the aircraft.
- (iii) An emergency floor path lighting system in the passenger compartment sufficient to facilitate the evacuation of the aircraft notwithstanding the failure of the lighting systems specified in paragraph (ii) of Scale G:

Provided that if the equipment specified in this sub-paragraph (iii) becomes unserviceable the aircraft may fly or continue to fly in accordance with arrangements approved by the Chief Executive. (36 of 1999 s. 3)

| | | | |
|-----------|---|------------|------------|
| Schedule: | 6 | 36 of 1999 | 01/07/1997 |
|-----------|---|------------|------------|

Remarks:

Adaptation amendments retroactively made - see 36 of 1999 s. 3

Article 14

Radio and Radio Navigation Equipment to be carried in Aircraft

1. Every aircraft shall be provided, when flying in the circumstances specified in the first column of the Table set forth in paragraph 2 of this Schedule, with the scales of equipment respectively indicated in that Table:

Provided that, if the aircraft is flying in a combination of such circumstances, the scales of equipment shall not on that account be required to be duplicated.

2.

TABLE

| Aircraft and Circumstances of Flight | Scale of Equipment Required | | | | | | | |
|---|--------------------------------|---|---|---|---|---|---|---|
| | A | B | C | D | E | F | G | H |
| (1) All aircraft within Hong Kong: | | | | | | | | |
| (a) when flying under Instrument Flight Rules within controlled airspace | A | | | | E | F | | |

| | | | | | |
|--|--------|-----|--|------------|--------|
| | | | | | * * |
| (b) when flying within any airspace in respect of which special rules are prescribed by the Rules of the Air in relation to a particular aerodrome, so as to require two-way radio communication with that aerodrome | A * | | | | |
| (c) when making an approach to landing at an aerodrome notified for the purpose of this sub-paragraph. | | | | | G * |
| (2) All aircraft (other than gliders) within Hong Kong: | | | | | |
| (a) when flying at or above flight level 245 | A * | | | E F * * | |
| (b) when flying within such airspace as may be notified for the purposes of this sub-paragraph, being airspace in respect of which special rules are prescribed by the said Rules | A * | | | E * | |
| (c) when flying at or above flight level 100 | | | | E * | |
| (3) All aircraft registered in Hong Kong, wherever they may be: | | | | | |
| (a) when flying for the purpose of public transport under Instrument Flight Rules: | | | | | |
| (i) while making an approach to landing | A | C D | | | H |
| (ii) on all other occasions | A | C | | | H |
| (b) multi-engined aircraft when flying for the purpose of public transport under Visual Flight Rules | A | | | | H |
| (c) single-engined aircraft when flying for the purpose of public transport under Visual Flight Rules: | | | | | |
| (i) over a route on which navigation is effected solely by visual reference to landmarks. | A | | | | |
| (ii) on all other occasions. | A | B | | | |
| Provided that aircraft which come within paragraphs (3)(b) and 3(c) above solely by virtue of the provisions of Article 98(6)(a)(iii) may carry instead of the requirements of the said paragraphs (3)(b) and 3(c): | | | | | |
| (aa) over a route on which navigation is not effected solely by visual reference to landmarks | A | B | | | |
| (bb) over water, beyond gliding distance from any land | A | | | | |
| (d) when flying under Instrument Flight Rules within controlled airspace and not required to comply with paragraph (3)(a) above | A * | | | | |

* Unless the appropriate air traffic control unit otherwise permits in relation to the particular flight and provided that the aircraft complies with any instructions which the air traffic control unit may give in the particular case.

3. The scales of radio and radio navigation equipment indicated in the foregoing Table shall be as follows:

Scale A

Radio equipment capable of maintaining direct two-way communication with the appropriate aeronautical radio stations.

Scale B

Radio navigation equipment capable of enabling the aircraft to be navigated on the intended route including such equipment as may be prescribed.

Scale C

Radio equipment capable of receiving from the appropriate aeronautical radio stations meteorological broadcasts relevant to the intended flight.

Scale D

Radio navigation equipment capable of receiving signals from one or more aeronautical radio stations on the surface to enable the aircraft to be guided to a point from which a visual landing can be made at the aerodrome at which the aircraft is to land.

Scale E

Secondary surveillance radar equipment.

Scale F

Radio and radio navigation equipment capable of enabling the aircraft to be navigated along the intended route including:

- (i) automatic direction finding equipment;
- (ii) distance measuring equipment; and
- (iii) VHF omni-range equipment.

Scale G

Radio navigation equipment capable of enabling the aircraft to make an approach to landing using the Instrument Landing System.

Scale H

Radio navigation equipment capable of enabling the aircraft to be navigated on the intended route including:

- (a) automatic direction finding equipment;
- (b) distance measuring equipment;
- (c) duplicated VHF omni-range equipment; and
- (d) a 75 MHz marker beacon receiver.

Except that an aircraft may fly notwithstanding that it does not carry the equipment specified in this Scale if it carries alternate radio navigation equipment or navigational equipment approved by the Chief Executive in writing in accordance with the provisions of Article 13(7) of this Order. (36 of 1999 s. 3)

Where not more than one item of equipment specified in this Scale is unserviceable when the aircraft is about to begin a flight, the aircraft may nevertheless take off on that flight if:

- (i) it is not reasonably practicable for the repair or replacement of that item to be carried out before the beginning of the flight;
- (ii) the aircraft has not made more than one flight since the item was last serviceable; and
- (iii) the commander of the aircraft has satisfied himself that, taking into account the latest information available as to the route and aerodrome to be used (including any planned diversion) and the weather conditions likely to be encountered, the flight can be made

safely and in accordance with any relevant requirements of the appropriate air traffic control unit.

4. In this Schedule-

(1) "automatic direction finding equipment" means radio navigation equipment which automatically indicates the bearing of any radio station transmitting the signals received by such equipment;

(2) "VHF omni-range equipment" means radio navigation equipment capable of giving visual indications of bearings of the aircraft by means of signals received from very high frequency omni-directional radio ranges;

(3) "distance measuring equipment" means radio navigation equipment capable of providing a continuous indication of the aircraft's distance from the appropriate aeronautical radio stations; and

(4) "secondary surveillance radar equipment" means such type of radio navigation equipment as may be notified as being capable of (a) replying to an interrogation from secondary surveillance radar units on the surface and (b) being operated in accordance with such instructions as may be given to the aircraft by the appropriate air traffic control unit.

| | | | | |
|-----------|------|--|-------------------|-----------------|
| Chapter: | 448C | AIR NAVIGATION (HONG KONG) ORDER 1995 | Gazette Number | Version Date |
| Schedule: | 8 | AREAS SPECIFIED IN CONNECTION WITH THE CARRIAGE OF FLIGHT NAVIGATORS AS MEMBERS OF THE FLIGHT CREWS OR APPROVED NAVIGATIONAL EQUIPMENT ON PUBLIC TRANSPORT AIRCRAFT | | 30/06/1997 |

Article 18(4)

The following areas are hereby specified for the purposes of Article 18(4) of this Order:

Area A-Arctic

All that area north of latitude 68° north, but excluding any part thereof within the area enclosed by rhumb lines joining successively the following points:

- 68° north latitude 00° east/west longitude
- 73° north latitude 15° east longitude
- 73° north latitude 30° east longitude
- 68° north latitude 45° east longitude
- 68° north latitude 00° east/west longitude

Area B-Antarctic

All that area south of latitude 55° south.

Area C-Sahara

All that area enclosed by rhumb lines joining successively the following points:

- 30° north latitude 05° west longitude
- 24° north latitude 11° west longitude
- 14° north latitude 11° west longitude
- 14° north latitude 28° east longitude
- 24° north latitude 28° east longitude
- 28° north latitude 23° east longitude
- 30° north latitude 15° east longitude
- 30° north latitude 05° west longitude

Area D-(deleted)

Area E-South America

All that area enclosed by rhumb lines joining successively the following points:

- 04° north latitude 72° west longitude
- 04° north latitude 60° west longitude
- 08° south latitude 42° west longitude
- 18° south latitude 54° west longitude

18° south latitude 60° west longitude
14° south latitude 72° west longitude
05° south latitude 76° west longitude
04° north latitude 72° west longitude

Area F-Pacific Ocean

All that area enclosed by rhumb lines joining successively the following points:

60° north latitude 180° east/west longitude
20° north latitude 128° east longitude
04° north latitude 128° east longitude
04° north latitude 180° east/west longitude
55° south latitude 180° east/west longitude
55° south latitude 82° west longitude
25° south latitude 82° west longitude
60° north latitude 155° west longitude
60° north latitude 180° east/west longitude

Area G-Australia

All that area enclosed by rhumb lines joining successively the following points:

18° south latitude 123° east longitude
30° south latitude 118° east longitude
30° south latitude 135° east longitude
18° south latitude 123° east longitude

Area H-Indian Ocean

All that area enclosed by rhumb lines joining successively the following points:

35° south latitude 110° east longitude
55° south latitude 180° east/west longitude
55° south latitude 10° east longitude
40° south latitude 10° east longitude
25° south latitude 60° east longitude
20° south latitude 60° east longitude
05° south latitude 43° east longitude
10° north latitude 55° east longitude
10° north latitude 73° east longitude
04° north latitude 77° east longitude
04° north latitude 92° east longitude
10° south latitude 100° east longitude
10° south latitude 110° east longitude
35° south latitude 110° east longitude

Area I-North Atlantic Ocean

All that area enclosed by rhumb lines joining successively the following points:

55° north latitude 15° west longitude
68° north latitude 28° west longitude
68° north latitude 60° west longitude
45° north latitude 45° west longitude
40° north latitude 60° west longitude
40° north latitude 19° west longitude
55° north latitude 15° west longitude

Area J-South Atlantic Ocean

All that area enclosed by rhumb lines joining successively the following points:

40° north latitude 60° west longitude
18° north latitude 60° west longitude
05° south latitude 30° west longitude
55° south latitude 55° west longitude
55° south latitude 10° east longitude
40° south latitude 10° east longitude
02° north latitude 05° east longitude
02° north latitude 10° west longitude
15° north latitude 25° west longitude
40° north latitude 19° west longitude
40° north latitude 60° west longitude

Area K-Northern Canada

All that area enclosed by rhumb lines joining successively the following points:

68° north latitude 130° west longitude
55° north latitude 115° west longitude
55° north latitude 70° west longitude
68° north latitude 60° west longitude
68° north latitude 130° west longitude

Area L-Northern Asia

All that area enclosed by rhumb lines joining successively the following points:

68° north latitude 56° east longitude
68° north latitude 160° east longitude
50° north latitude 125° east longitude
50° north latitude 56° east longitude
68° north latitude 56° east longitude

Area M-Southern Asia

All that area enclosed by rhumb lines joining successively the following points:

50° north latitude 56° east longitude
50° north latitude 125° east longitude
40° north latitude 110° east longitude

30° north latitude 110° east longitude
30° north latitude 80° east longitude
35° north latitude 80° east longitude
35° north latitude 56° east longitude
50° north latitude 56° east longitude

Note:

The Former Area D was an area in the Arabian Desert.

| | | | | |
|-----------|---|--|------------|------------|
| Schedule: | 9 | FLIGHT CREW OF AIRCRAFT, LICENCES AND RATINGS | 36 of 1999 | 01/07/1997 |
|-----------|---|--|------------|------------|

Remarks:

Adaptation amendments retroactively made - see 36 of 1999 s. 3

Article 20

PART A-LICENCES

Minimum Age, Period of Validity, Privileges

I. Aeroplane Pilots

Private Pilot's Licence (Aeroplanes)

Minimum age-17 years

No Maximum Period of Validity

Privileges: The holder of the licence shall be entitled to fly as pilot in command or co-pilot of an aeroplane of any of the types specified or otherwise falling within the aircraft rating included in the licence:

Provided that:

- (a) he shall not fly such an aeroplane for the purpose of public transport or aerial work save as hereinafter provided-
 - (i) he may fly such an aeroplane for the purpose of aerial work which consists of:
 - (aa) the giving of instruction in flying, if his licence includes a flying instructor's rating or an assistant flying instructor's rating; or
 - (bb) the conducting of flying tests for the purposes of this Order, in either case in an aeroplane owned, or operated under arrangements entered into, by a flying club of which the person giving the instruction or conducting the test and the person receiving the instruction or undergoing the test are both members;
 - (ii) he may fly such an aeroplane for the purpose of aerial work which consists of:
 - (aa) towing a glider in flights; or
 - (bb) a flight for the purpose of dropping of persons by parachute, in either case in an aeroplane owned, or operated under arrangements entered into by a club of which the holder of the licence and any person carried in the aircraft or in any glider towed by the aircraft are members;
- (b) he shall not receive any remuneration for his services as a pilot, other than remuneration for the giving of such instruction or the conducting of such flying tests as are specified in sub-paragraph (a)(i) of this proviso;
- (c) he shall not, unless his licence includes an instrument rating (aeroplanes), fly as pilot in command of such an aeroplane-
 - (i) on a flight outside controlled airspace-

- (aa) when the flight visibility is less than 1 1/2 nautical miles; or
- (bb) when any passenger is carried and the aeroplane is flying either above 3000 feet above mean sea level in Instrument Meteorological Conditions or at or below 3000 feet above mean sea level in a flight visibility of less than 3 nautical miles;
- (ii) on a special VFR flight in a control zone in a flight visibility of less than 5 nautical miles except on a route or in an aerodrome traffic zone notified for the purposes of this sub-paragraph;
- (iii) out of sight of the surface; and
- (d) he shall not fly as pilot in command of such an aeroplane at night unless-
 - (i) his licence includes a night rating (aeroplanes), and
 - (ii) his licence includes an instrument rating (aeroplanes) or he has within the immediately preceding 13 months carried out as pilot in command not less than 5 take-offs and 5 landings at a time when the depression of the centre of the sun was not less than 12° below the horizon.

Commercial Pilot's Licence (Aeroplanes)

Minimum Age-18 years

Maximum Period of Validity-10 years

Privileges:

(1) The holder of the licence shall be entitled to exercise the privileges of a Private Pilot's Licence (Aeroplanes) which includes a night rating (aeroplanes) and shall be entitled to fly as pilot in command of an aeroplane-

- (a) on a special VFR flight notwithstanding that the flight visibility is less than 1 1/2 nautical miles;
- (b) when the aeroplane is taking off or landing at any place notwithstanding that the flight visibility below cloud is less than 1 nautical mile.

(2) He shall be entitled to fly as pilot in command of an aeroplane of a type specified in Part I of the aircraft rating included in the licence when the aeroplane is engaged on a flight for any purpose whatsoever:

Provided that-

- (a) he shall not, unless his licence includes an instrument rating (aeroplanes), fly such an aeroplane on any scheduled journey;
- (b) he shall not fly such an aeroplane at night unless his licence includes an instrument rating (aeroplanes) or he has within the immediately preceding 13 months carried out as pilot in command not less than five take-offs and five landings at a time when the depression of the centre of the sun was not less than 12° below the horizon;
- (c) he shall not, unless his licence includes an instrument rating (aeroplanes), fly any such aeroplane of which the maximum total weight authorized exceeds 2300 kg on any flight for the purpose of public transport, except a flight beginning and ending at the same aerodrome and not extending beyond 25 nautical miles from that aerodrome;
- (d) he shall not fly such an aeroplane on a flight for the purpose of public transport unless it is certified for single pilot operation;
- (e) he shall not fly such an aeroplane on any flight for the purpose of public transport after he attains the age of 60 years unless the aeroplane is fitted with dual controls and carries a second pilot who has not attained the age of 60 years and who holds an appropriate licence under this Order entitling him to act as pilot in command or co-pilot of that aeroplane.

(3) He shall be entitled to fly as co-pilot of any aeroplane of a type specified in the aircraft rating included in the licence when the aeroplane is engaged on a flight for any purpose whatsoever:

Provided that he shall not act as co-pilot of any aeroplane whose maximum total weight authorized exceeds 20000 kg on any flight for the purpose of public transport after he attains the age of 60 years.

(4) He shall not at any time after he attains the age of 65 years act as pilot in command or co-pilot of any aeroplane on a flight for the purpose of public transport.

Airline Transport Pilot's Licence (Aeroplanes)

Minimum Age-21 years

Maximum Period of Validity-10 years

Privileges: The holder of the licence shall be entitled to exercise the privileges of a Commercial Pilot's Licence (Aeroplanes) except the proviso (d) to paragraph (2) of those privileges shall not apply and the holder of the licence shall not at any time after he attains the age of 60 years act as pilot in command or co-pilot of any aeroplane for the purpose of public transport if its maximum total weight authorized exceeds 20000 kg.

2. Helicopter and Gyroplane Pilots

Private Pilot's Licence (Helicopters and Gyroplanes)

Minimum Age-17 years

No Maximum Period of Validity

Privileges: The holder of the licence shall be entitled to fly as pilot in command or co-pilot of a helicopter or gyroplane of any of the types specified in the aircraft rating included in the licence:

Provided that-

- (a) he shall not fly such a helicopter or gyroplane for the purpose of public transport or aerial work other than aerial work which consists of-
 - (i) the giving of instruction in flying if his licence includes a flying instructor's rating or an assistant flying instructor's rating;
 - (ii) the conducting of flying tests for the purposes of this Order;
in either case in a helicopter or gyroplane owned, or operated under arrangements entered into, by a flying club of which the person giving the instruction or conducting the test and the person receiving the instruction or undergoing the test are both members;
- (b) he shall not receive any remuneration for his services as a pilot on a flight other than remuneration for the giving of such instruction or the conducting of such flying tests as are specified in paragraph (a) of this proviso;
- (c) he shall not fly as pilot in command of such a gyroplane at night unless his licence includes a night rating (helicopters and gyroplanes) and he has within the immediately preceding 13 months carried out as pilot in command not less than 5 take-offs and 5 landings at a time when the depression of the centre of the sun was not less than 12° below the horizon;
- (d) he shall not fly as pilot in command of such a helicopter at night unless-
 - (i) his licence includes a night rating (helicopters and gyroplanes); and
 - (ii) his licence includes an instrument rating (helicopters) or he has within the immediately preceding 13 months carried out as pilot in command not less than 5 flights, each consisting of a take-off, a transition from hover to forward flight, a climb to at least 500 feet and a landing, at a time when the depression of the centre of the sun was not less than 12° below the horizon;
- (e) he shall not unless his licence includes an instrument rating (helicopters) fly as pilot in command or co-pilot of such a helicopter flying in airspace notified for the purposes of this Schedule:
 - (i) in conditions such that he cannot comply with the specified minimum weather

- provisions; or
(ii) in circumstances which require compliance with Instrument Flight Rules.

Commercial Pilot's Licence (Helicopters and Gyroplanes)

Minimum Age-18 years

Maximum Period of Validity-10 years

Privileges:

(1) The holder of the licence shall be entitled to exercise the privileges of a Private Pilot's Licence (Helicopters and Gyroplanes) which includes a night rating (helicopters and gyroplanes).

(2) He shall be entitled to fly as pilot in command of any helicopter or gyroplane specified in Part I of the aircraft rating included in the licence when the helicopter or gyroplane is engaged on a flight for any purpose whatsoever:

Provided that-

- (a) he shall not, unless his licence includes an instrument rating (helicopters), fly such a helicopter on any scheduled journey or on any flight for the purpose of public transport in Instrument Meteorological Conditions;
- (b) he shall not fly such a helicopter or gyroplane on a flight for the purpose of public transport unless it is certificated for single pilot operation;
- (c) he shall not fly such a gyroplane at night unless he has within the immediately preceding 13 months carried out as a pilot in command not less than 5 take-offs and 5 landings at a time when the depression of the centre of the sun was not less than 12° below the horizon;
- (d) he shall not fly such a helicopter at night unless his licence includes an instrument rating (helicopters) or he has within the immediately preceding 13 months carried out as pilot in command not less than 5 flights, each consisting of a take-off, a transition from hover to forward flight, a climb to at least 500 feet and a landing, at a time when the depression of the centre of the sun was not less than 12° below the horizon;
- (e) he shall not fly such a helicopter or gyroplane on any flight for the purpose of public transport after he attains the age of 60 years unless the helicopter or gyroplane is fitted with dual controls and carries a second pilot who has not attained the age of 60 years and who holds an appropriate licence under this Order entitling him to act as pilot in command or co-pilot of that helicopter or gyroplane;
- (f) he shall not unless his licence includes an instrument rating (helicopters) fly as pilot in command or co-pilot of such a helicopter flying in airspace notified for the purposes of this Schedule:
 - (i) in conditions such that he cannot comply with the specified minimum weather provisions; or
 - (ii) in circumstances which require compliance with the Instrument Flight Rules.

(3) He shall be entitled to fly as co-pilot of any helicopter or gyroplane specified in the aircraft rating included in the licence when the helicopter or gyroplane is engaged on a flight for any purpose whatsoever:

Provided that he shall not act as co-pilot of any helicopter or gyroplane whose maximum total weight authorized exceeds 20000 kg on any flight for the purpose of public transport after he attains the age of 60 years.

(4) He shall not at any time after he attains the age of 65 years act as pilot in command or co-pilot of any helicopter or gyroplane on a flight for the purpose of public transport.

Airline Transport Pilot's Licence (Helicopters and Gyroplanes)

Minimum Age-21 years

Maximum Period of Validity-10 years

Privileges: The holder of the licence shall be entitled to exercise the privileges of a

Commercial Pilot's Licence (Helicopters and Gyroplanes) except that proviso (b) to paragraph (2) of those privileges shall not apply and the holder of the licence shall not at any time after he attains the age of 60 years act as pilot in command or co-pilot of any helicopter or gyroplane for the purpose of public transport if its maximum total weight authorized exceeds 20000 kg.

3. Balloon and Airship Pilots

Private Pilot's Licence (Balloons and Airships)

Minimum Age-17 years

No Maximum Period of Validity

Privileges: The holder of the licence shall be entitled to fly as pilot in command of any type of balloon or airship specified in Part 1 of the aircraft rating included in the licence and co-pilot of any type of balloon or airship specified in such aircraft rating:

Provided that-

- (a) he shall not fly such balloon or airship for the purpose of public transport or aerial work, other than aerial work which consists of the giving of instruction in flying or the conducting of flying tests in either case in a balloon or airship owned, or operated under arrangements entered into, by a flying club of which the person giving the instruction or conducting the test and the person receiving the instruction or undergoing the test are both members;
- (b) he shall not receive any remuneration for his services as pilot on a flight other than remuneration for the giving of such instruction or the conducting of such flying tests as are specified in paragraph (a) of this proviso;
- (c) he shall not fly such a balloon unless he has within the immediately preceding 13 months carried out as pilot in command in a free balloon 5 flights each of not less than 5 minutes duration.

Commercial Pilot's Licence (Balloons)

Minimum Age-18 years

Maximum Period of Validity-6 months*

Privileges:

(1) The holder of the licence shall be entitled to exercise the privileges of a Private Pilot's Licence (Balloons and Airships).

(2) He shall be entitled to fly, when the balloon is flying for any purpose whatsoever, as pilot in command or co-pilot of any type of balloon specified in the aircraft rating included in the licence:

Provided that he shall not act as pilot in command on a flight for the purpose of the public transport of passengers unless he has within the immediately preceding 90 days carried out as pilot in command in a free balloon 3 flights each of not less than 5 minutes duration.

Commercial Pilot's Licence (Airships)

Minimum Age-17 years

Maximum Period of Validity-10 years

Privileges:

(1) The holder of the licence shall be entitled to exercise the privileges of a Private Pilot's Licence (Balloons and Airships).

(2) He shall be entitled to fly, when the airship is flying for any purpose whatsoever, as pilot in command of any type of airship specified in Part 1 of the aircraft rating included in the licence and as co-pilot of any type of airship specified in such aircraft rating.

4. Glider Pilots

Private Pilot's Licence (Gliders)

Minimum Age-17 years
No Maximum Period of Validity

Privileges: The holder of the licence shall be entitled to fly as pilot in command or co-pilot of a glider of any of the types specified in the aircraft rating included in the licence:

Provided that:

- (a) he shall not fly such a glider for the purpose of public transport or aerial work other than aerial work which consists of:
 - (i) the giving of instruction in gliding if his licence includes a flying instructor's rating or an assistant instructor's rating; or
 - (ii) the conducting of flying tests for the purposes of this Order; in either case in a glider owned, or operated under arrangements entered into, by a flying club of which the person giving the instruction or conducting the test and the person receiving the instruction or undergoing the test are both members.
- (b) he shall not receive any remuneration for his services as a pilot on a flight other than remuneration for the giving of such instruction or the conducting of such flying tests as are specified in paragraph (a) of this proviso.

Commercial Pilot's Licence (Glanders)

Minimum Age-18 years
Maximum Period of Validity-10 years

Privileges: The holder of the licence shall be entitled to fly for any purpose as pilot in command or co-pilot of-

- (a) any glider of which the maximum total weight authorized does not exceed 680 kg;
- (b) any glider of which the maximum total weight authorized exceeds 680 kg and which is of a type specified in the rating included in the licence.

5. Other Flight Crew

Flight Navigator's Licence

Minimum Age-21 years
Maximum Period of Validity-10 years

Privileges: The holder of the licence shall be entitled to act as flight navigator in any aircraft.

Flight Engineer's Licence

Minimum Age-21 years
Maximum Period of Validity-10 years

Privileges: The holder of the licence shall be entitled to act as flight engineer in any type of aircraft specified in the aircraft rating included in the licence.

Flight Radiotelephony Operator's General Licence

Minimum Age-18 years
Maximum Period of Validity-10 years

Privileges: The holder of the licence shall be entitled to operate radiotelephony apparatus in any aircraft.

Flight Radiotelephony Operator's Restricted Licence

Minimum Age-17 years
Maximum Period of Validity-10 years

Privileges: The holder of the licence shall be entitled to operate radiotelephony apparatus in any aircraft if the stability of the frequency radiated by the transmitter is maintained automatically but shall not be entitled to operate the transmitter, or to adjust its frequency, except by the use of external switching devices.

Flight Radiotelephony Operator's Licence
Minimum Age-20 years
Maximum Period of Validity-12 months

Privileges: The holder of the licence shall be entitled to operate radiotelegraphy and radiotelephony apparatus in any aircraft.

Flight Radiotelegraphy Operator's Temporary Licence
Minimum Age-18 years
Maximum Period of Validity-12 months

Privileges: The holder of the licence shall be entitled to operate radiotelegraphy and radiotelephony apparatus in any aircraft under the supervision of a person who is the holder of a flight radiotelegraphy operator's licence.

PART B-RATINGS

1. The following ratings may be included in a pilot's licence granted under Part IV of this Order, and subject to the provisions of this Order and of the licence, the inclusion of a rating in a licence shall have the consequences respectively specified as follows-

Aircraft Ratings: The licence shall entitle the holder to act as pilot of aircraft of the types specified in the aircraft rating and different types of aircraft may be specified in respect of different privileges of a licence.

Instrument Rating (Aeroplanes) shall entitle the holder of the licence to act as pilot in command or co-pilot of an aeroplane flying in airspace notified for the purpose of this Schedule either in conditions such that he cannot comply with the specified minimum weather provisions or in circumstances which require compliance with the Instrument Flight Rules.

Instrument Rating (Helicopters) shall entitle the holder of the licence to act as pilot in command or co-pilot of a helicopter flying in airspace notified for the purpose of this Schedule either in conditions such that he cannot comply with the specified minimum weather provisions or in circumstances which require compliance with the Instrument Flight Rules.

Night Rating (Aeroplanes) shall entitle the holder of a private pilot's licence (aeroplanes) to act as pilot in command of an aeroplane at night.

Night Rating (Helicopters and Gyroplanes) shall entitle the holder of a private pilot's licence (helicopters and gyroplanes) to act as pilot in command of a helicopter or gyroplane at night.

Towing Rating (Flying Machines) shall entitle the holder of the licence to act as pilot of a flying machine while towing a glider in flight for the purposes of public transport or aerial work.

Flying Instructor's Rating shall entitle the holder of the licence to give instruction in flying aircraft of such types as may be specified in the rating for that purpose.

Assistant Flying Instructor's Rating shall entitle the holder of the licence to give instruction in flying aircraft of such types as may be specified in the rating for that purpose:

Provided that-

- (a) such instruction shall only be given under the supervision of a person present during the take-off and landing at the aerodrome at which the instruction is to begin and end and holding a pilot's licence endorsed with a flying instructor's rating; and
- (b) an assistant flying instructor's rating shall not entitle the holder of the licence to give directions to the person undergoing instruction in respect of the performance by that person of:
 - (i) his first solo flight;
 - (ii) his first solo flight by night;

- (iii) his first solo cross-country flight otherwise than by night; or
- (iv) his first solo cross-country flight by night.

2. An aircraft rating included in a flight engineer's licence shall entitle the holder of the licence to act as flight engineer only of aircraft of a type specified in the aircraft rating.

3. For the purposes of this Schedule-

"Solo flight" means a flight on which the pilot of the aircraft is not accompanied by a person holding a pilot's licence granted or rendered valid under this Order.

"Cross-country flight" means any flight during the course of which the aircraft is more than 3 nautical miles from the aerodrome of departure.

PART C-CERTIFICATE OF TEST OR EXPERIENCE

1. (a) A certificate of test or certificate of experience required by Article 20(4) of this Order shall not be appropriate to the functions to be performed on a flight unless it is a certificate appropriate to the description of the flight according to the following Table:

| Case | Class of Licence | Description of Flight | Certificate Required |
|------|---|--|--|
| A. | Private Pilot's Licence (Aeroplanes) Private Pilot's Licence (Helicopters and Gyroplanes) | Any flight within the privileges of the licence | Certificate of test or certificate of experience |
| B. | Commercial Pilot's Licence (Aeroplanes) Commercial Pilot's Licence (Helicopters and Gyroplanes) Commercial Pilot's Licence (Gliders) Commercial Pilot's Licence (Airships) Airline Transport Pilot's Licence (Aeroplanes) Airline Transport Pilot's Licence (Helicopters and Gyroplanes) | Carriage of passengers on a flight in respect of which the holder of the licence receives remuneration | Certificate of test |
| C. | Commercial Pilot's Licence (Aeroplanes) Commercial Pilot's Licence (Helicopters and Gyroplanes) Commercial Pilot's Licence (Gliders) Commercial Pilot's Licence (Airships) Airline Transport Pilot's Licence (Aeroplanes) Airline Transport Pilot's Licence (Helicopters and Gyroplanes) | For public transport | Certificate of test |
| D. | Commercial Pilot's Licence (Aeroplanes) Commercial Pilot's Licence (Helicopters and Gyroplanes) Commercial Pilot's Licence (Gliders) Commercial Pilot's Licence (Airships) Airline Transport Pilot's Licence (Aeroplanes) Airline Transport Pilot's Licence (Helicopters and Gyroplanes) | For aerial work | Certificate of test or certificate of experience |
| E. | Commercial Pilot's Licence (Aeroplanes) Commercial Pilot's Licence (Helicopters and Gyroplanes) Commercial Pilot's Licence (Gliders) | Any flight within the privileges of a Private Pilot's Licence | Certificate of test or certificate of experience |

| | | | |
|----|--|--|--|
| | Commercial Pilot's Licence (Airships) | | |
| | Airline Transport Pilot's Licence (Aeroplanes) | | |
| | Airline Transport Pilot's Licence (Helicopters and Gyroplanes) | | |
| F. | Flight Navigator's Licence | Flights to which Article 18(4) of this Order applies | Certificate of experience |
| G. | Flight Engineer's Licence | For public transport | Certificate of test |
| H. | Flight Engineer's Licence | Any flight other than for public transport | Certificate of test or certificate of experience |

(b) For the purposes of this Part of this Schedule references to Cases are references to the cases indicated in the first Column of the Table in paragraph 1(a) of this Part of this Schedule.

2. Certificate of test

A certificate of test required by Article 20(4) or 20(5) of this Order shall be signed by a person authorized by the Chief Executive to sign certificates of this kind and shall certify the following particulars- (36 of 1999 s. 3)

- (a) the functions to which the certificate relates;
- (b) that the person signing the certificate is satisfied that on a date specified in the certificate the holder of the licence or personal flying logbook of which the certificate forms part, as the case may be, passed an appropriate test of his ability to perform the functions to which the certificate relates;
- (c) the type of aircraft or flight simulator in or by means of which the test was conducted; and
- (d) the date on which it was signed.

3. Nature of test

The appropriate test referred to in paragraph 2 of this Part of this Schedule shall be:

- (a) in the case of a test which entitles the holder of the licence of which the certificate forms part to act as pilot in command and/or co-pilot of aircraft of the type specified in the certificate, a test of the pilot's competence to fly the aircraft as pilot in command and/or co-pilot and shall where the Chief Executive so specifies in respect of the whole or part of a test be conducted in an aircraft in flight or by means of a flight simulator approved by the Chief Executive;
- (b) in the case of a test which entitles the holder of the licence of which the certificate forms part to act as flight engineer of aircraft of the type specified in the certificate, a test of the flight engineer's competence to perform the duties of a flight engineer in the type of aircraft to be used on the flight and shall, where the Chief Executive so specifies in respect of the whole or part of a test, be conducted in an aircraft in flight or by means of a flight simulator approved by the Chief Executive;
- (c) in the case of a test which entitles the holder of the licence of which the certificate forms part to perform the functions to which an Instrument Rating relates a test of his ability to perform the functions to which the rating relates and shall, where the Chief Executive so specifies in respect of the whole or part of the test, be conducted in an aircraft in flight or by means of a flight simulator approved by the Chief Executive;
- (d) in the case of a test which entitles the holder of the licence of which the certificate

forms part to perform the functions to which a flying instructor's rating or an assistant flying instructor's rating relates, a test of his ability to perform the functions to which the rating relates and shall where the Chief Executive so specifies in respect of the whole or part of the test be conducted in an aircraft in flight.

(36 of 1999 s. 3)

4. Period of Validity of Certificate of Test

- (a) A certificate of test required by Article 20(4) of this Order in respect of a Commercial Pilot's Licence (Balloons) shall not be valid in relation to a flight made more than 13 months after the date of the test which it certifies and in respect of any other licence shall not be valid in relation to a flight made more than 13 months in Cases A, B, E and H, or more than 6 months in Cases C, D and G, after the date of the test which it certifies:

Provided that in the case of Cases C, D and G two certificates of test shall together be deemed to constitute a valid certificate of test if they certify flying tests conducted on two occasions within the period of 13 months preceding the flight on which the functions are to be performed, such occasions being separated by an interval of not less than 4 months, and if both certificates are appropriate to those functions.

- (b) A certificate of test required by Article 20(5) of this Order shall not be valid in relation to a flight made more than 13 months in the case of an instrument rating (aeroplanes) and an assistant flying instructor's rating or more than 25 months in the case of a flying instructor's rating, after the date of the test which it certifies.

5. Certificate of experience

A certificate of experience required by Article 20(4) of this Order shall be signed by a person authorized by the Chief Executive to sign such a certificate and shall certify the following particulars: (36 of 1999 s. 3)

- (a) the functions to which the certificate relates;
- (b) in the case of a pilot or flight engineer, that on the date on which the certificate was signed the holder of the licence or personal flying logbook of which it forms part, as the case may be, produced his personal flying logbook to the person signing the certificate and satisfied him that he had appropriate experience in the capacity to which his licence relates within the appropriate period specified in paragraph 6 of this Part of this Schedule;
- (c) in the case of a flight navigator, that on the date on which the certificate was signed the holder of the licence of which it forms part produced his navigation logs, charts and workings of astronomical observations to the person signing the certificate and satisfied him that he had appropriate experience in the capacity to which the licence relates within the appropriate period specified in paragraph 6 of this Part of this Schedule;
- (d) in the case of a pilot or flight engineer, the type or types of aircraft in which the experience was gained;
- (e) the date on which it was signed.

6. Period of experience

A certificate of experience shall not be valid unless the experience certified was gained within the period of 13 months preceding the signing of the certificate in the case of Cases A, E, F and H, or 6 months preceding the signing of the certificate in the case of Case D.

7. Period of Validity of Certificate of Experience

A certificate of experience in respect of a Commercial Pilot's Licence (Balloons) shall not be valid more than 13 months after it was signed and in respect of any other licence shall not be valid more than 6 months after it was signed for Case D, nor more than 13 months after it was signed for any other Case.

Note:

* In respect of the privileges of a Private Pilot's Licence the maximum period of validity shall be as given for that licence.

| | | | |
|-----------|----|-------------------------------------|------------|
| Schedule: | 10 | AIR TRAFFIC CONTROLLERS: RATINGS | 30/06/1997 |
|-----------|----|-------------------------------------|------------|

Article 66(2)

1. The holder of a licence which includes ratings of two or more of the classes specified in paragraph 2 of this Schedule shall not at any one time perform the functions specified in respect of more than one of those ratings:

Provided that the functions of any one of the following groups of ratings may be exercised at the same time-

- (a) The aerodrome control rating and the approach control rating;
- (b) The approach control rating and the approach radar control rating; except that the functions of the approach control rating shall not be exercised at the same time as the functions of the approach radar control rating if the service being provided under the latter is a surveillance radar approach terminating at a point less than 2 nautical miles from the point of intersection of the glide path with the runway;
- (c) The area control rating and the area radar control rating.

2. Ratings of the following classes may be included in an air traffic controller's licence (other than a student air traffic controller's licence) granted under Article 65 of this Order and, subject to the provisions of this Order and of the licence, the inclusion of a rating in a licence shall have the consequences respectively specified as follows-

(1) Aerodrome Control Rating shall entitle the holder of the licence for which the rating is valid, to provide air traffic control service (but not with any type of radar equipment for which a radar control rating is required under this paragraph) for any aircraft on the manoeuvring area or apron of that aerodrome or which is flying in the vicinity of the aerodrome traffic zone by visual reference to the surface.

(2) Approach Control Rating shall entitle the holder of the licence, at any aerodrome for which the rating is valid, to provide air traffic control service (but not with any type of radar equipment for which a radar control rating is required under this paragraph) for any aircraft which is flying in the vicinity of the aerodrome traffic zone whether or not it is flying by visual reference to the surface.

(3) Approach Radar Control Rating shall entitle the holder of the licence, at any aerodrome for which the rating is valid, to provide air traffic control service with the aid of any type of surveillance radar equipment for which the rating is valid for any aircraft which is flying within 40 nautical miles of the aerodrome traffic zone whether or not it is flying by visual reference to the surface.

(4) Precision Approach Radar Control Rating shall entitle the holder of the licence, at any aerodrome or which the rating is valid, to provide air traffic control service with the aid of any type of precision approach radar equipment for which the rating is valid.

(5) Area Control Rating shall entitle the holder of the licence at any place for which the rating is valid, to provide an air traffic control service without the aid of any surveillance radar equipment.

(6) Area Radar Control Rating shall entitle the holder of the licence, at any place for which

the rating is valid, to provide air traffic control service with the aid of any type of surveillance radar equipment for which the rating is valid.

(7) Area Radar Control (Aerodrome) Rating shall entitle the holder of the licence, at any aerodrome for which the rating is valid, to provide air traffic control service with the aid of any type of surveillance radar equipment for which the rating is valid.

| | | | | |
|-----------|----|---|------------|------------|
| Schedule: | 11 | PUBLIC TRANSPORT- OPERATIONAL REQUIREMENTS | 36 of 1999 | 01/07/1997 |
|-----------|----|---|------------|------------|

Remarks:

Adaptation amendments retroactively made - see 36 of 1999 s. 3

PART A-OPERATIONS MANUAL

Article 25

Information and instructions relating to the following matters shall be included in the operations manual referred to in Article 25(2) of this Order:

- (i) the number of the crew to be carried in the aircraft, on each stage of any route to be flown, and the respective capacities in which they are to act, and instructions as to the order and circumstances in which command is to be assumed by members of the crew;
- (ii) the respective duties of each member of the crew and the other members of the operating staff;
- (iii) the scheme referred to in Article 54(1)(c)(i) of this Order;
- (iv) such technical particulars concerning the aircraft, its engines and equipment and concerning the performance of the aircraft as may be necessary to enable the flight crew of the aircraft to perform their respective duties;
- (v) the manner in which the quantities of fuel and oil to be carried by the aircraft are to be computed and records of fuel and oil carried and consumed on each stage of the route to be flown are to be maintained; the instructions shall take account of all circumstances likely to be encountered on the flight including the possibility of failure of one or more of the aircraft engines;
- (vi) the manner in which the quantity, if any, of oxygen equipment to be carried in the aircraft for the purpose of complying with Scales L1 and L2 in Schedule 5 to this Order is to be computed;
- (vii) the check system to be followed by the crew of the aircraft prior to and on take-off, on landing and in an emergency, so as to ensure that the operating procedures contained in the operations manual and in the flight manual or performance schedule forming part of the relevant certificate of airworthiness are complied with;
- (viii) the circumstances in which a radio watch is to be maintained;
- (ix) the circumstances in which oxygen is to be used by the crew of the aircraft, and by passengers;
- (x) communication, navigational aids, aerodromes, local regulations, in-flight procedures, approach and landing procedures and such other information as the operator may deem necessary for the proper conduct of flight operations; the information referred to in this paragraph shall be contained in a route guide, which may be in the form of a separate volume;
- (xi) the reporting in flight to the notified authorities of meteorological observations;
- (xii) the minimum altitudes for safe flight on each stage of the route to be flown and any planned diversion therefrom, such minimum altitudes being not lower than

any which may be applicable under the law of Hong Kong or of the countries whose territory is to be flown over;

- (xiii) the particulars referred to in Article 30 of this Order;
- (xiv) emergency flight procedures, including procedures for the instruction of passengers in the position and use of emergency equipment and procedures to be adopted when the commander of the aircraft becomes aware that another aircraft or vessel is in distress and needs assistance;
- (xv) in the case of aircraft intended to fly at an altitude of more than 49000 feet the procedures for the use of cosmic radiation detection equipment;
- (xvi) the labelling and marking of dangerous goods, the manner in which they must be loaded on an aircraft and the responsibilities of members of the crew in respect of the carriage of dangerous goods:

Provided that in relation to any flight which is not one of a series of flights between the same two places it shall be sufficient if, to the extent that it is not practicable to comply with paragraphs (x) and (xii), the manual contains such information and instructions as will enable the equivalent data to be ascertained before take-off.

PART B-CREW TRAINING AND TESTS

Article 27

1. The training, experience, practice and periodical tests required under Article 27(2) of this Order in the case of members of the crew of an aircraft engaged on a flight for the purpose of public transport shall be as follows-

(1) The Crew

Every member of the crew shall-

- (a) have been tested within the relevant period by or on behalf of the operator as to his knowledge of the use of the emergency and life saving equipment required to be carried in the aircraft on the flight; and
- (b) have practised within the relevant period under the supervision of the operator or of a person appointed by him for the purpose, the carrying out of the duties required of him in case of an emergency occurring to the aircraft, either in an aircraft of the type to be used on the flight or in apparatus approved by the Chief Executive for the purpose and controlled by persons to approved. (36 of 1999 s. 3)

(2) Pilots

- (a) Every pilot included in the flight crew who is intended by the operator to fly as pilot in circumstances requiring compliance with the Instrument Flight Rules shall within the relevant period have been tested by or on behalf of the operator-
 - (i) as to his competence to perform his duties while executing normal manoeuvres and procedures in flight, in an aircraft of the type to be used on the flight including the use of the instruments and equipment provided in the aircraft;
 - (ii) as to his competence to perform his duties in instrument flight conditions while executing emergency manoeuvres and procedures in flight, in an aircraft of the type to be used on the flight, including the use of the instruments and equipment provided in the aircraft.

A pilot's ability to carry out normal manoeuvres and procedures shall be tested in the aircraft in flight.

The other tests required by this sub-paragraph may be conducted either in the aircraft in flight, or under the supervision of a person approved by the Chief Executive for the purpose by means of a flight simulator approved by the Chief Executive under Article 20(10) of this Order. The tests specified in sub-paragraph (2)(a)(i) of this paragraph when conducted in the aircraft

in flight shall be carried out either in actual instrument flight conditions or in instrument flight conditions simulated by means approved by the Chief Executive.

- (b) Every pilot included in the flight crew whose licence does not include an instrument rating or who, notwithstanding the inclusion of such a rating in his licence, is not intended by the operator to fly in circumstances requiring compliance with the Instrument Flight Rules, shall within the relevant period have been tested, by or on behalf of the operator, in flight in an aircraft of the type to be used on the flight-
 - (i) as to his competence to act as pilot thereof, while executing normal manoeuvres procedures, and
 - (ii) as to his competence to act as pilot thereof while executing emergency manoeuvres and procedures.
- (c) Every pilot included in the flight crew who is seated at the flying controls during take-off or landing shall within the relevant period-
 - (i) have been tested as to his proficiency using instrument approach-to-land systems of the type in use at the aerodromes of intended landing and any alternative aerodromes, such test being carried out either in flight in instrument flight conditions or in instrument flight conditions simulated by means approved by the Chief Executive or under the supervision of a person approved by the Chief Executive for the purpose by means of a flight simulator approved by the Chief Executive, and
 - (ii) have carried out when seated at the flying controls not less than three take-offs and three landings in aircraft of the type to be used on the flight. (36 of 1999 s. 3)

(3) Flight Engineers

Every flight engineer included in the flight crew shall within the relevant period have been tested by or on behalf of the operator-

- (a) as to his competence to perform his duties while executing normal procedures in flight, in an aircraft of the type to be used on the flight.
- (b) as to his competence to perform his duties while executing emergency procedures in flight, in an aircraft of the type to be used on the flight.

A flight engineer's ability to carry out normal procedures shall be tested in an aircraft in flight. The other tests required by this sub-paragraph may be conducted either in the aircraft in flight, or under supervision of a person approved by the Chief Executive for the purpose by means of a flight simulator approved by the Chief Executive. (36 of 1999 s. 3)

(4) Flight Navigators and Flight Radio Operators

Every flight navigator and flight radio operator whose inclusion in the flight crew is required under Article 18(4) and (5) respectively of this Order shall within the relevant period have been tested by or on behalf of the operator as to his competence to perform his duties in conditions corresponding to those likely to be encountered on the flight-

- (a) in the case of a flight navigator, using equipment of the type to be used in the aircraft on the flight for purposes of navigation;
- (b) in the case of a flight radio operator, using radio equipment of the type installed in the aircraft to be used on the flight, and including a test of his ability to carry out emergency procedures.

(5) Aircraft Commanders

- (a) The pilot designated as commander of the aircraft for the flight shall within the relevant period have demonstrated to the satisfaction of the operator that he has adequate knowledge of the route to be taken, the aerodromes of take-off and landing, and any alternate aerodromes, including in particular his knowledge of-
 - (i) the terrain;

- (ii) the seasonal meteorological conditions;
 - (iii) the meteorological communications, and air traffic facilities, services and procedures; and
 - (iv) the search and rescue procedures, and the navigational facilities, relevant to the route.
- (b) In determining whether a pilot's knowledge of the matters referred to in sub-paragraph (a) is sufficient to render him competent to perform the duties of aircraft commander on the flight, the operator shall take into account the pilot's flying experience in conjunction with the following-
- (i) the experience of other members of the intended flight crew;
 - (ii) the influence of terrain and obstructions on departure and approach procedures at the aerodromes of take-off and intended landing and at alternate aerodromes;
 - (iii) the similarity of the instrument approach procedures and let-down aids to those with which the pilot is familiar;
 - (iv) the dimensions of runways which may be used in the course of the flight in relation to the performance limits of aircraft of the type to be used on the flight;
 - (v) the reliability of meteorological forecasts and the probability of difficult meteorological conditions in the areas to be traversed;
 - (vi) the adequacy of the information available regarding the aerodrome of intended landing and any alternate aerodromes;
 - (vii) the nature of air traffic control procedures and familiarity of the pilot with such procedures;
 - (viii) the influence of terrain on route conditions and the extent of the assistance obtainable enroute from navigational aids and air-to-ground communication facilities; and
 - (ix) the extent to which it is possible for the pilot to become familiar with unusual aerodrome procedures and features of the route by means of ground instruction and training devices.

(6) For the purposes of this paragraph-

"instrument flight conditions" means weather conditions such that the pilot is unable to fly by visual reference to objects outside the aircraft;

"relevant period" means a period which immediately precedes the commencement of the flight, being a period-

- (a) in the case of sub-paragraph (2)(c)(ii) of this paragraph, of 3 months;
- (b) in the case of sub-paragraphs (2)(a)(ii), (2)(b)(ii), 2(c)(i) and (3)(b) of this paragraph, of 6 months;
- (c) in the case of sub-paragraphs (1), (2)(a)(i), (2)(b)(i), (3)(a), (4) and (5)(a) of this paragraph, of 13 months:

Provided that-

- (i) any pilot of the aircraft to whom the provisions of sub-paragraphs (2)(a)(ii), (2)(b)(ii) or (2)(c)(i) and any flight engineer of the aircraft to whom the provisions of sub-paragraph (3)(b) of this paragraph apply shall for the purposes of the flight be deemed to have complied with such requirement respectively within the relevant period if he has qualified to perform his duties in accordance therewith on two occasions within the period of 13 months immediately preceding the flight, such occasions being separated by an interval of not less than 4 months;
- (ii) the requirements of sub-paragraph (5)(a) shall be deemed to have been complied with within the relevant period by a pilot designated as commander of the aircraft for the flight if, having become qualified so to act on flights between the same places over the same route more than 13 months before commencement of the flight, he has within the period of 13 months immediately preceding the flight flown as pilot of an aircraft between those places over the route.

2. (1) The records required to be maintained by an operator under Article 27(2) of this Order shall be accurate and up-to-date records so kept as to show, on any date, in relation to each person who has during the period of two years immediately preceding that date flown as a member of the crew of any public transport aircraft operated by that operator-

- (a) the date and particulars of each test required by this Schedule undergone by that person during the said period including the name and qualifications of the examiner;
- (b) the date upon which the person last practised the carrying out of duties referred to in paragraph 1(1)(b) of this Schedule;
- (c) the operator's conclusions based on each such test and practice as to that person's competence to perform his duties;
- (d) the date and particulars of any decision taken by the operator during the said period in pursuance of paragraph 1(5)(a) of this Schedule including particulars of the evidence upon which that decision was based.

(2) The operator shall whenever called upon to do so by any authorized person produce for the inspection of any person so authorized all records referred to in the preceding sub-paragraphs and furnish to any such person all such information as he may require in connection with any such records and produce for his inspection all log books, certificates, papers and other documents, whatsoever which he may reasonably require to see for the purpose of determining whether such records are complete or of verifying the accuracy of their contents.

(3) The operator shall at the request of any person in respect of whom he is required to keep records as aforesaid furnish to that person, or to any operator of aircraft for the purpose of public transport by whom that person may subsequently be employed, particulars of any qualifications in accordance with this Schedule obtained by such person whilst in his service.

PART C-TRAINING MANUAL

The following information and instructions in relation to the training, experience, practice and periodical tests required under Article 27(2) of this Order shall be included in the training manual referred to in Article 26(2) of this Order-

- (i) the manner in which the training, practice and periodical tests required under Article 27(2) and specified in Part B of Schedule 11 to this Order are to be carried out;
- (ii) (a) the minimum qualifications and experience which the operator requires of persons appointed by him to give or to supervise the said training, practice and periodical tests; and
 - (b) the type of training, practice and periodical tests which each such person is appointed to give or to supervise; and
 - (c) the type of aircraft in respect of which each such person is appointed to give or to supervise the said training, practice and periodical tests;
- (iii) the minimum qualifications and experience required of each member of the crew undergoing the said training, practice and periodical tests;
- (iv) the syllabus for, and specimen forms for recording, the said training, practice and periodical tests;
- (v) the manner in which instrument flight conditions and engine failure are to be simulated in the aircraft in flight;
- (vi) the extent to which the said training and testing is permitted in the course of flights for the purpose of public transport;
- (vii) the use to be made in the said training and testing of apparatus approved for the purpose by the Chief Executive. (36 of 1999 s. 3)

| | | | | |
|-----------|----|---|------------|------------|
| Schedule: | 12 | DOCUMENTS TO BE CARRIED BY AIRCRAFT REGISTERED IN HONG KONG | 36 of 2000 | 16/06/2000 |
|-----------|----|---|------------|------------|

Articles 57 and 59

On a flight for the purpose of public transport:

Documents A, B, C, D, E, F, H and, if the flight is external air navigation, Document G.

On a flight for the purpose of aerial work:

Documents A, B, C, E, F and, if the flight is external air navigation, Document G.

On a flight, being external air navigation for a purpose other than public transport of aerial work:

Documents A, B, C and G.

For the purposes of this Schedule:

"A" means the licence in force in respect of the aircraft radio station installed in the aircraft, and the current telecommunications log book required by this Order; (36 of 2000 s. 28)

"B" means the certificate of airworthiness in force in respect of the aircraft:

Provided that, with the permission in writing of the Chief Executive, an aircraft to which Article 25 of this Order applies need not carry the flight manual as part of this document if it carries an operations manual which includes-

- (i) the information shown in the Limitations and Emergency Procedures section of the flight manual; and
- (ii) performance instructions which are derived from the material contained in the performance section of the flight manual.

"C" means the licences of the members of the flight crew of the aircraft;

"D" means one copy of the load sheet, if any, required by Article 28 of this Order in respect of the flight;

"E" means one copy of each certificate of maintenance review, if any, in force in respect of the aircraft;

"External air navigation" means any flight which includes passage over the territory of any country other than Hong Kong.

"F" means the technical log, if any, in which entries are required to be made under Article 10;

"G" means the certificate of registration in force in respect of the aircraft;

"H" means the operations manual, if any, required by Article 25(2)(a)(iii) of this Order to be carried out on the flight;

(36 of 1999 s. 3)

| | | | | |
|-----------|----|--|------------------------|------------|
| Schedule: | 13 | | 23 of 1998; 36 of 1999 | 01/07/1997 |
|-----------|----|--|------------------------|------------|

Remarks:

Adaptation amendments retroactively made - see 23 of 1998 s. 2; 36 of 1999 s. 3

Article 91

PART A-PROVISIONS REFERRED TO IN ARTICLE 91(5)

| Article of Order | Subject Matter |
|------------------|--|
| 3 | Aircraft flying unregistered |
| 5 | Aircraft flying with false or incorrect markings |
| 9(1)(a) | Flight without appropriate maintenance |

| | |
|-----------------|--|
| 9(1)(b) | Flight without a certificate of maintenance review |
| 10 | Failure to keep technical log |
| 11 | Flight without a certificate of release to service |
| 13 | Flight without required equipment |
| 14 | Flight without required radio equipment |
| 15 | Failure to keep log book |
| 16 | Requirement to weigh aircraft and keep weight schedule |
| 18 | Crew requirement |
| 19 | Requirement for appropriate licence |
| 20(4) and (5) | Requirement for appropriate certificates |
| 20(6) | Prohibition of flight after failure of test |
| 20(7)(a) | Flight without valid medical certificate |
| 20(8) | Flight in unfit condition |
| 23 | Instruction in flying without appropriate licence and rating |
| 25 | Operations manual requirement |
| 26 | Training manual requirement |
| 27 | Operator's responsibilities in connection with crew |
| 28 | Requirements for loading aircraft |
| 29 | Operational restrictions on aircraft |
| 30 | Aerodrome operating minima-aircraft registered in Hong Kong |
| 31 | Aerodrome operating minima-aircraft registered outside Hong Kong |
| 31A | Non-public transport aircraft-aerodrome operating minima |
| 32 | Pre-flight action by commander of aircraft |
| 33 | Requirement for pilot to remain at controls |
| 34 | Duties of commander on flight for public transport of passengers |
| 35 | Requirements for radio station in aircraft to be licensed and for operation of same |
| 36 | Requirements for minimum navigation performance system |
| 37 | Use of flight recorders and preservation of records |
| 38 | Towing of gliders |
| 39 | Towing, picking-up and raising of persons and articles by aircraft |
| 40 and 41 | Dropping of persons, animals and articles from aircraft |
| 42 | Requirement for aerial application certificate |
| 45 | Carriage of persons in or on any part of an aircraft not designed for that purpose |
| 46 | Requirement for exits and break-in markings |
| 50 | Prohibition of smoking in aircraft |
| 51 | Requirement to obey lawful commands of aircraft commander |
| 52 | Prohibition of stowaways |
| 54(3) | Operator's obligation to obtain flight time records of flight crew |
| 55(2) | Flight crew member's obligation to inform operator of flight times |
| 56 | Flight time limitations |
| 64(2) | Breach of Rules of the Air |
| 66 (except (4)) | Requirement for licensing of air traffic controllers and aerodrome flight information service officers |
| 67 | Requirement for aerodrome information service manual |
| 69 | Flight in contravention of restriction of flying regulations |
| 70 | Flight by balloons, kites, airships, gliders and parascending parachutes |
| 71 | Requirement for licensed aerodrome |

| | |
|-----------------|--|
| 73(5) | Contravention of condition of aerodrome licence |
| 74 | Use of radio equipment at aerodromes |
| 75 | Requirement to keep records at aerodrome |
| 79 | Use of aeronautical lights |
| 80(1) | Prohibition of dangerous lights |
| 80(2) | Failure to extinguish or screen dangerous lights |
| 82(1) and (2) | Management of aviation fuel at aerodromes |
| 86 (except (4)) | Requirement to report occurrences |
| 89 | Obstruction of persons performing duties under Order |

PART B-PROVISIONS REFERRED TO IN ARTICLE 91(6)

| Article of Order | Subject Matter |
|------------------|---|
| 6 | Flight for the purpose of public transport without an air operator's certificate |
| 7 | Flight without a certificate of airworthiness |
| 43 | Prohibition of carriage of weapons and munitions of war |
| 44 | Prohibition of carriage of dangerous goods |
| 47 | Endangering safety of aircraft |
| 48 | Endangering safety of persons or property |
| 49 | Prohibition of drunkenness in aircraft |
| 54(1) | Operator's obligations to regulate flight times of flight crew |
| 54(2) | Operator's obligations not to allow flight by crew in dangerous state of fatigue |
| 55(1) | Crew's obligation not to fly in dangerous state of fatigue |
| 63 (except (3)) | Use of false or unauthorized documents and records |
| 82(3) | Use of aviation fuel which is unfit for use in aircraft |
| 84 | Restriction of flights for aerial photography and survey by aircraft registered outside Hong Kong |
| 85 | Operator's or commanders' obligations in respect of flights over any place outside Hong Kong |
| 86(4) | Making false reports |
| 87 | Flight in contravention of direction not to fly |

(23 of 1998 s. 2; 36 of 1999 s. 3)

| | | | | |
|-----------|----|------------------|------------|------------|
| Schedule: | 14 | RULES OF THE AIR | 36 of 1999 | 01/07/1997 |
|-----------|----|------------------|------------|------------|

Remarks:

Adaptation amendments retroactively made - see 36 of 1999 s. 3

Article 64

SECTION I

INTERPRETATION

1. In these Rules, unless the context otherwise requires-
"Air traffic control clearance" means authorization by an air traffic control unit for an aircraft to proceed under conditions specified by that unit.

"Anti-collision light" means-

- (a) in relation to rotorcraft a flashing red light;
- (b) in relation to any other aircraft a flashing red or flashing white lights;

and in either case showing in all directions for the purpose of enabling the aircraft to be more readily detected by the pilots of distant aircraft.

"Apron" means the part of an aerodrome provided for the stationing of aircraft for the embarkation and disembarkation of passengers, the loading and unloading of cargo and parking.

"Ground visibility" means the horizontal visibility at ground level.

"IFR flight" means a flight conducted in accordance with the Instrument Flight Rules in Section VI of these Rules.

"Manoeuvring area" means the part of an aerodrome provided for the take-off and landing of aircraft and the movement of aircraft on the surface, excluding the apron and any part of the aerodrome provided for the maintenance of aircraft.

"Runway" means an area, whether or not paved, which is provided for the take-off or landing run of aircraft.

"VFR Flight" means a flight conducted in accordance with the Visual Flight Rules in Section V of these Rules.

SECTION II

GENERAL

2. Application of Rules to Aircraft

These Rules, in so far as they are applicable in relation to aircraft, shall, subject to the provisions of Rule 29 of these Rules, apply in relation to-

- (a) all aircraft within Hong Kong; and
- (b) all aircraft registered in Hong Kong wherever they may be.

3. Misuse of Signals and Markings

(1) A signal or marking to which a meaning is given by these Rules, or which is required by these Rules to be used in circumstances or for a purpose therein specified, shall not be used except with that meaning, or for that purpose.

(2) A person in an aircraft or on an aerodrome or at any place at which an aircraft is taking off or landing shall not make any signal which may be confused with a signal specified in the Rules and, except with lawful authority, shall not make any signal which he knows or ought reasonably to know to be a signal in use for signalling to or from any of Her Majesty's naval, military or air force aircraft.

4. Reporting hazardous conditions

The commander of an aircraft shall, on meeting with hazardous conditions in the course of a flight, or as soon as possible thereafter, send to the appropriate air traffic control unit by the quickest means available information containing such particulars of the hazardous conditions as may be pertinent to the safety of other aircraft.

5. Low flying

(1) Subject to the provisions of paragraph (2) and (3) of this Rule:

- (a) An aircraft other than a helicopter shall not fly over any congested area of a city, town or settlement below-
 - (i) such height as would enable the aircraft to alight clear of the area and without danger to persons or property on the surface, in the event of failure of a power unit and if such an aircraft is towing a banner such height shall be

calculated on the basis that the banner shall not be dropped within the congested area; or

- (ii) a height of 1500 feet above the highest fixed object within 2000 feet of the aircraft, whichever is the higher.
 - (b) A helicopter shall not fly below such height as would enable it to alight without danger to persons or property on the surface, in the event of failure of a power unit.
 - (c) Except with the permission in writing of the Chief Executive and in accordance with any conditions therein specified a helicopter should not fly over a congested area of a city, town or settlement below a height of 1500 feet above the highest fixed object within 2000 feet of the helicopter. (36 of 1999 s. 3)
 - (d) An aircraft shall not fly-
 - (i) over, or within 3000 feet of, any assembly in the open air of more than 1000 persons assembled for the purpose of witnessing or participating in any organised event, except with the permission in writing of the Chief Executive and in accordance with any conditions therein specified and with the consent in writing of the organisers of the event; or (36 of 1999 s. 3)
 - (ii) below such height as would enable it to alight clear of the assembly in the event of the failure of a power unit and if such an aircraft is towing a banner such height shall be calculated on the basis that the banner shall not be dropped within 3000 feet of the assembly:

Provided that, where a person is charged with an offence under this Order by reason of a contravention of this sub-paragraph, it shall be a good defence to prove that the flight of the aircraft over, or within 3000 feet of, the assembly was made at a reasonable height and for a reason not connected with the assembly or with the event which was the occasion for the assembly.
 - (e) An aircraft shall not fly closer than 500 feet to any person, vessel, vehicle or structure.
- (2) (a) The provisions of paragraphs (1)(a)(ii) and (1)(c) of this Rule shall not apply to an aircraft flying-
- (i) on a route notified for the purposes of this Rule, or
 - (ii) on a special VFR flight as defined in Rule 23 of these Rules in accordance with instructions given for the purposes of that Rule by the appropriate air traffic control unit.
- (b) Paragraphs (1)(d) and (e) of this Rule shall not apply to an aircraft which is being used for police purposes.
- (c) Paragraphs (1)(d) and (e) of this Rule shall not apply to the flight of an aircraft over or within 3000 feet of an assembly of persons gathered for the purpose of witnessing an event which consists wholly or principally of an aircraft race or contest or an exhibition of flying, if the aircraft is taking part in such race, contest or exhibition or is engaged on a flight arranged by, or made with the consent in writing of, the organisers of the event.
- (d) Paragraph (1)(e) of this Rule shall not apply to-
- (i) any aircraft while it is landing or taking off in accordance with normal aviation practice;
 - (ii) any glider while it is hill-soaring;
 - (iii) any aircraft while it is flying in accordance with proviso (f) of Article 40(2) of this Order;
 - (iv) any aircraft while it is flying in accordance with the terms of an aerial application certificate granted to the operator thereof under Article 42 of this Order;
 - (v) any aircraft while it is flying for the purpose of picking up or dropping tow ropes, banners or similar articles at an aerodrome in accordance with Articles 39(2) or proviso (e) of Article 40(2) of this Order.

(3) Nothing in this Rule shall prohibit an aircraft from flying in such a manner as is necessary for the purpose of saving life.

(4) Nothing in this Rule shall prohibit any aircraft from flying in accordance with normal aviation practice, for the purpose of taking off from, landing at or practising approaches to landing at, or checking navigational aids or procedures at, a Government aerodrome or a licensed aerodrome in Hong Kong or at any aerodrome elsewhere:

Provided that the practising of approaches to landing shall be confined to the airspace customarily used by aircraft when landing or taking off in accordance with normal aviation practice at the aerodrome concerned.

(5) Nothing in this Rule shall apply to any captive balloon or kite.

Simulated instrument flight

- (6) An aircraft shall not be flown in simulated instrument flight conditions unless-
- (a) the aircraft is fitted with dual controls, which are functioning properly;
 - (b) an additional pilot (in this Rule called "a safety pilot") is carried in a second control seat of the aircraft for the purpose of rendering such assistance as may be necessary to the pilot of the aircraft; and
 - (c) if the safety pilot's field of vision is not adequate both forward and to each side of the aircraft, a third person, being a competent observer, occupies a position in the aircraft which from his field of vision makes good the deficiencies in that of the safety pilot, and from which he can readily communicate with the safety pilot.

For the purposes of this Rule the expression "simulated instrument flight" means a flight during which mechanical or optical devices are used in order to reduce the field of vision or the range or visibility from the cockpit of the aircraft.

Practice Instrument Approaches

(7) Within Hong Kong an aircraft shall not carry out instrument approach practice when flying in Visual Meteorological Conditions unless-

- (a) the appropriate air traffic control unit has previously been informed that the flight is to be made for the purpose of instrument approach practice; and
- (b) if the flight is not being carried out in simulated instrument flight conditions, a competent observer is carried in such a position in the aircraft that he has an adequate field of vision and can readily communicate with the pilot flying the aircraft.

SECTION III

LIGHTS AND OTHER SIGNALS TO BE SHOWN OR MADE BY AIRCRAFT GENERAL

8. (1) For the purposes of this Section of these Rules the horizontal plane of light shown in an aircraft means the plane which would be the horizontal plane passing through the source of that light, if the aircraft were in level flight.

(2) Where by reason of the physical construction of an aircraft it is necessary to fit more than one lamp in order to show a light required by this Section of these Rules, the lamps shall be so fitted and constructed that, so far as is reasonably practicable, not more than one such lamp is visible from any one point outside the aircraft.

(3) Where in these Rules a light is required to show through specified angles in the horizontal plane, the lamps giving such light shall be so constructed and fitted that the light is visible from any point in any vertical plane within those angles throughout angles of 90 degrees above and below the horizontal plane, but, so far as is reasonably practicable, through no greater angle, either in the horizontal plane or the vertical plane.

(4) Where in these Rules a light is required to show in all directions, the lamps giving such light shall be so constructed and fitted that, so far as is reasonably practicable, the light is visible

from any point in the horizontal plane and on any vertical plane passing through the source of that light.

9. Display of lights by aircraft

- (1) (a) By night an aircraft shall display such of the lights specified in these Rules as may be appropriate to the circumstances of the case, and shall not display any other lights which might obscure or otherwise impair the visibility of, or be mistaken for, such lights.
- (b) By day an aircraft fitted with an anti-collision light shall display such a light in flight.
- (2) A flying machine on an aerodrome in Hong Kong shall:
 - (a) display by night either the lights which it would be required to display when flying or the lights specified in Rule 11(2)(c) of these Rules unless it is stationary on the apron or part of the aerodrome provided for the maintenance of aircraft;
 - (b) display when stationary on the apron by day or night with engines running a red anti-collision light, if fitted:

Provided that a helicopter to which Article 25 of the Order applies may, when stationary on an offshore installation, switch off such an anti-collision light in accordance with a procedure contained in the operations manual of the helicopter as a signal to ground personnel that it is safe to approach the helicopter for the purpose of embarkation or disembarkation of passengers or the loading or unloading of cargo.

(3) Notwithstanding the provisions of this section of the Rules the commander of an aircraft may switch off or reduce the intensity of any flashing light fitted to the aircraft if such a light does or is likely to:

- (a) adversely affect the performance of the duties of any member of the flight crew; or
- (b) subject an outside observer to unreasonable dazzle.

10. Failure of navigation and anti-collision lights

(1) In Hong Kong, in the event of the failure of any light which is required by these Rules to be displayed at night, if the light cannot be immediately repaired or replaced the aircraft shall not depart from the aerodrome and, if in flight, shall land as soon as in the opinion of the commander of the aircraft it can safely do so, unless authorized by the appropriate air traffic control unit to continue its flight.

(2) In Hong Kong, in the event of a failure of an anti-collision light when flying by day, an aircraft may continue to fly by day provided that the light is repaired at the earliest practicable opportunity.

11. Flying Machines

- (1) A flying machine when flying at night shall display light as follows-
 - (a) in the case of a flying machine registered in Hong Kong having a maximum total weight authorized of more than 5700 kg or any other flying machine registered in Hong Kong which conforms to a type first issued with a type certificate on or after 1st January 1991 the system of lights in paragraph (2)(b) of this Rule;
 - (b) in the case of a flying machine registered in Hong Kong which conforms to a type first issued with a type certificate before 1st January 1991 having a maximum total weight authorized of 5700 kg or less, any one of the following systems of lights:-
 - (i) that specified in paragraph (2)(a) of this Rule, or that specified in paragraph (2)(b); or
 - (ii) that specified in paragraph (2)(d), excluding sub-paragraph (ii);
 - (c) in the case of any other flying machines one of the systems of lights specified in paragraph (2) of this Rule.
- (2) The systems of lights referred to in paragraph (1) of this Rule are as follows:-

- (a) (i) a steady green light of at least five candela showing to the starboard side through an angle of 100 degrees from dead ahead in the horizontal plane; and
- (ii) a steady red light of at least five candela showing to the port side through an angle of 100 degrees from dead ahead in the horizontal plane; and
- (iii) a steady white light of at least three candela showing through angles of 70 degrees from dead astern to each side in the horizontal plane;
- (b) (i) the lights specified in sub-paragraph (a) of this paragraph; and
- (ii) an anti-collision light;
- (c) the lights specified in sub-paragraph (a) of this paragraph, but all being flashing lights flashing together;
- (d) the lights specified in sub-paragraph (a), but all being flashing lights flashing together in alternation with one or both of the following:
 - (i) a flashing white light of at least twenty candela showing in all directions;
 - (ii) a flashing red light of at least twenty candela showing through angles of 70 degrees from dead astern to each side in the horizontal plane.

(3) If the lamp showing either the red or green light specified in paragraph (2)(a) of this Rule is fitted more than 2 metres from the wing tip, a lamp may, notwithstanding the provisions of Rule 9(1) of these Rules, be fitted at the wing tip to indicate its position showing a steady light of the same colour through the same angle.

12. Gliders

A glider while flying at night shall display either a steady red light of at least five candela showing in all directions, or lights in accordance with Rule 11(2) and (3) of these Rules.

13. Free Balloons

A free balloon while flying at night shall display a steady red light of at least five candela showing in all directions, suspended not less than 5 metres and not more than 10 metres below the basket, or if there is no basket, below the lowest part of the balloon.

14. Captive balloons and kites

(1) A captive balloon or kite while flying at night at a height exceeding 60 metres above the surface shall display lights as follows:-

- (a) a group of two steady lights consisting of a white light placed 4 metres above a red light, both being of at least five candela and showing in all directions, the white light being placed not less than 5 metres or more than 10 metres below the basket, or if there is no basket, below the lowest part of the balloon or kite;
- (b) on the mooring cable, at intervals of not more than 300 metres measured from the group of lights referred to in sub-paragraph (a) of this paragraph, groups of two lights of the colour and power and in the relative positions specified in that sub-paragraph, and, if the lowest group of lights is obscured by cloud, an additional group below the cloud base; and
- (c) on the surface, a group of three flashing lights arranged in a horizontal plane at the apexes of a triangle, approximately equilateral, each side of which measures at least 25 metres; one side of the triangle shall be approximately at right angles to the horizontal projection of the cable and shall be delimited by two red lights; the third light shall be a green light so placed that the triangle enclose the object on the surface to which the balloon or kite is moored.

(2) A captive balloon while flying by day at a height exceeding 60 metres above the surface shall have attached to its mooring cable at intervals of not more than 200 metres measured from the basket, or, if there is no basket, from the lowest part of the balloon, tubular streamers not less than 40 centimetres in diameter and 2 metres in length, and marked with alternative bands of red and white 50 centimetres wide.

(3) A kite flown in the circumstances referred to in paragraph (2) of this Rule shall have attached to its mooring cable either:-

- (a) tubular streamers as specified in paragraph (2) of this Rule; or
- (b) at intervals of not more than 100 metres measured from the lowest part of the kite, streamers of not less than 80 centimetres long and 30 centimetres wide at their widest point and marked with alternate bands of red and white 10 centimetres wide.

15. Airships

(1) Except as provided in paragraph (2) of this Rule, an airship while flying at night shall display the following:-

- (a) a steady white light of at least five candela showing through angles of 110 degrees from dead ahead to each side in the horizontal plane;
- (b) a steady green light of at least five candela showing to the starboard side through an angle of 110 degrees from dead ahead in the horizontal plane;
- (c) a steady red light of at least five candela showing to the port side through an angle of 110 degrees from dead ahead in the horizontal plane;
- (d) a steady white light of at least five candela showing through angles of 70 degrees from dead astern to each side in the horizontal plane; and
- (e) an anti-collision light.

(2) An airship while flying at night shall display, if it is not under command, or has voluntarily stopped its engines, or is being towed, the following steady lights:-

- (a) the white lights referred to in paragraph (1)(a) and (d) of this Rule;
- (b) two red lights, each of at least five candela and showing in all directions suspended below the control car so that one is at least 4 metres above the other and at least 8 metres below the control car; and
- (c) if the airship is making way but not otherwise, the green and red lights referred to in paragraph (1)(b) and (c) of this Rule:

Provided that an airship while picking up its moorings, notwithstanding that this is not under command, shall display only the lights specified in paragraph (1) of this Rule.

(3) An airship, while moored within Hong Kong by night, shall display the following steady lights:

- (a) when moored to a mooring mast, at or near a white light of at least five candela showing in all directions;
- (b) when moored otherwise than to a mooring mast:-
 - (i) a white light of at least five candela showing through angles of 110 degrees from dead ahead to each side in the horizontal plane;
 - (ii) a white light of at least five candela showing through angles of 70 degrees from dead astern to each side in the horizontal plane.

(4) An airship while flying by day, if it is not under command, or has voluntarily stopped its engines, or is being towed, shall display two black balls suspended below the control car so that one is at least 4 metres above the other and at least 8 metres below the control car.

(5) For the purposes of this Rule:-

- (a) an airship shall be deemed not to be under command when it is unable to execute a manoeuvre which it may be required to execute by or under these Rules;
- (b) an airship shall be deemed to be making way when it is not moored and is in motion relative to the air.

SECTION IV

GENERAL FLIGHT RULES

16. Weather reports and forecasts

(1) Immediately before an aircraft flies the commander of the aircraft shall examine the current reports and forecasts of the weather conditions on the proposed flight path, being reports and forecasts which it is reasonably practicable for him to obtain, in order to determine whether Instrument Meteorological Conditions prevail or are likely to prevail during any part of the flight.

(2) An aircraft which is unable to communicate by radio with an air traffic control unit at the aerodrome of destination shall not begin a flight to an aerodrome within a control zone if the information which it is reasonably practicable for the commander of the aircraft to obtain indicates that it will arrive at that aerodrome when the ground visibility is less than 5 nautical miles or the cloud ceiling is less than 1500 feet, unless the commander of the aircraft has obtained from an air traffic control unit at that aerodrome permission to enter the aerodrome traffic zone.

17. Rules for avoiding aerial collisions

(1) General

- (a) Notwithstanding that the flight is being made with air traffic control clearance it shall remain the duty of the commander of an aircraft to take all possible measures to ensure that his aircraft does not collide with any other aircraft.
- (b) An aircraft shall not be flown in such proximity to other aircraft as to create a danger of collision.
- (c) Aircraft shall not fly in formation unless the commanders of the aircraft have agreed to do so.
- (d) An aircraft which is obliged by these Rules to give way to another aircraft shall avoid passing over or under the other aircraft, or crossing ahead of it, unless passing well clear of it.
- (e) An aircraft which has the right-of-way under this Rule shall maintain its course and speed.
- (f) For the purposes of this Rule a glider and a flying machine which is towing it shall be considered to be a single aircraft under the command of the commander of the towing flying machine.

(2) Converging

- (a) Subject to the provision of paragraphs (3) and (4) of this Rule, an aircraft in the air shall give way to other converging aircraft as follows:-
 - (i) flying machines shall give way to airships, gliders and balloons;
 - (ii) airships shall give way to gliders and balloons;
 - (iii) gliders shall give way to balloons.
- (b) Subject to the provisions of sub-paragraph (a) of this paragraph, when two aircraft are converging in the air at approximately the same altitude, the aircraft which has the other on its right shall give way:

Provided that mechanically driven aircraft shall give way to aircraft which are towing other aircraft or objects.

(3) Approaching head-on

When two aircraft are approaching head-on or approximately so in the air and there is danger of collision, each shall alter its course to the right.

(4) Overtaking

An aircraft which is being overtaken in the air shall have the right-of-way and the overtaking aircraft, whether climbing, descending or in horizontal flight, shall keep out of the way of the other aircraft by altering course to the right, and shall not cease to keep out of the way of the other aircraft until that other aircraft has been passed and is clear, notwithstanding any change in the relative positions of the two aircraft:

Provided that a glider overtaking another glider in Hong Kong may alter its course to the right or to the left.

(5) Flight in the vicinity of an aerodrome

Without prejudice to the provision of Rule 35, a flying machine, glider or airship while flying in the vicinity of what the commander of the aircraft knows or ought reasonably to know to be an aerodrome or moving on an aerodrome shall unless, in the case of an aerodrome having an air traffic control unit, that unit otherwise authorizes:-

- (a) conform to the pattern of traffic formed by other aircraft intending to land at that aerodrome, or keep clear of the airspace in which the pattern is formed; and
- (b) make all turns to the left unless ground signals otherwise indicate.

(6) Order of landing

- (a) An aircraft while landing or on final approach to land shall have the right-of-way over other aircraft in flight or on the ground or water;
- (b) In the case of two or more flying machines, gliders or airships approaching any place for the purpose of landing, the aircraft at the lower altitude shall have the right-of-way, but it shall not cut in front of another aircraft which is in the final approach to land or overtake that aircraft:

Provided that-

- (i) when an air traffic control unit has communicated to any aircraft an order of priority for landing, the aircraft shall approach to land in that order; and
- (ii) when the commander of an aircraft is aware that another aircraft is making an emergency landing, he shall give way to that aircraft, and at night, notwithstanding that he may have received permission to land, shall not attempt to land until he has received further permission to do so.

(7) Landing and take-off

- (a) A flying machine, glider or airship shall take-off and land in the direction indicated by the ground signals or, if no such signals are displayed, into the wind, unless good aviation practice demands otherwise.
- (b) A flying machine or glider shall not land on a runway at an aerodrome if the runway is not clear of other aircraft unless, in the case of an aerodrome having an air traffic control unit, that unit otherwise authorizes.
- (c) Where take-offs and landings are not confined to a runway-
 - (i) a flying machine or glider when landing shall leave clear on its left any aircraft which has landed or is already landing or about to take-off; if such a flying machine or glider is about to turn it shall turn to the left after the commander of the aircraft has satisfied himself that such action will not interfere with other traffic movements; and
 - (ii) a flying machine about to take-off shall take up position and manoeuvre in such a way as to leave clear on its left any aircraft which has already taken-off or is about to take-off.
- (d) A flying machine after landing shall move clear of the landing area as soon as it is possible to do so unless in the case of an aerodrome having an air traffic control unit, that unit otherwise authorizes.

18. Aerobatic manoeuvres

An aircraft shall not carry out any aerobatic manoeuvre:

- (a) over a congested area of any city, town or settlement; or
- (b) within controlled airspace except with the consent of the appropriate air traffic control unit.

19. Right-hand traffic rule

An aircraft which is flying within Hong Kong in sight of the ground and following a road, railway, canal or coastline, or any other line of landmarks, shall keep such line of landmarks on its

left:

Provided that this rule shall not apply to an aircraft flying within controlled airspace notified for the purposes of Rule 21 of these Rules in accordance with instructions given by the appropriate air traffic control unit.

20. Notification of arrival and departure

(1) The commander of an aircraft who has caused notice of its intended arrival at any aerodrome to be given to the air traffic control unit or other authority at that aerodrome shall ensure that the air traffic control unit or other authority at that aerodrome is informed as quickly as possible of any change of intended destination and any estimated delay in arrival of 45 minutes or more.

(2) The commander of an aircraft arriving at or departing from an aerodrome in Hong Kong shall take all reasonable steps to ensure upon landing or prior to departure, as the case may be, that notice of that event be given to the person in charge of the aerodrome, or to the air traffic control unit or aerodrome flight information service unit at the aerodrome.

(3) Without prejudice to the provisions of Rule 27 to these Rules, before taking off on any flight from an aerodrome in Hong Kong, being a flight whose intended destination is more than 40 kilometres from the aerodrome of departure, the commander of an aircraft of which the maximum total weight authorized exceeds 5700 kg shall cause a flight plan containing such particulars of the intended flight as may be necessary for search and rescue purposes to be communicated to the air traffic control unit notified for the purpose of this Rule.

21. Flight in Class A airspace

In relation to flights in Visual Meteorological Conditions in Class A airspace, the commander of an aircraft shall comply with Rules 27 and 28 of these Rules as if the flights were IFR flights:

Provided that the commander of the aircraft shall not elect to continue the flight in compliance with the Visual Flight Rules for the purposes of Rule 27(3).

22. Choice of VFR or IFR

Subject to the provisions of Rule 21 of these Rules an aircraft shall always be flown in accordance with the Visual Flight Rules or the Instrument Flight Rules:

Provided that in Hong Kong an aircraft flying at night:

- (a) outside a control zone shall be flown in accordance with the Instrument Flight Rules; or
- (b) in a control zone shall be flown in accordance with the Instrument Flight Rules unless it is on a Special VFR flight.

22A. Speed Limitations

(1) Subject to paragraph (3) an aircraft shall not fly below flight level 100 at a speed which according to its air speed indicator is more than 250 knots unless it is flying in accordance with the terms of a written permission of the Chief Executive. (36 of 1999 s. 3)

(2) The Chief Executive may grant a permission for the purpose of this Rule subject to such conditions as he thinks fit and either generally or in respect of any aircraft or class of aircraft.

- (3) Paragraph (1) shall not apply to: (36 of 1999 s. 3)
- (a) flight in Class A airspace;
 - (b) flight in Class B airspace;
 - (c) IFR flight in Class C airspace;
 - (d) VFR flight in Class C airspace or VFR flight or IFR flight in Class D airspace when authorized by the appropriate air traffic control unit;
 - (e) the flight of an aircraft flying in accordance with the "A Conditions" or the "B Conditions" set forth in Schedule 2 to the Ordinance, when authorised by the

appropriate air traffic control unit.

SECTION V

VISUAL FLIGHT RULES

23. The Visual Flight Rules

The Visual Flight Rules shall be as follows:

- (a) Within Class B airspace:
 - (i) an aircraft flying within Class B airspace at or above flight level 100 shall remain clear of cloud and in a flight visibility of at least 8 kilometres;
 - (ii) an aircraft flying within Class B airspace below flight level 100 shall remain clear of cloud and in a flight visibility of at least 5 kilometres;
- (b) Within Class C, Class D or Class E airspace:
 - (i) an aircraft flying within Class C, Class D or Class E airspace at or above flight level 100 shall remain at least 1500 metres horizontally and 1000 feet vertically away from cloud and in a flight visibility of at least 8 kilometres;
 - (ii) an aircraft flying within Class C, Class D or Class E airspace below flight level 100 shall remain at least 1500 metres horizontally and 1000 feet vertically away from cloud and in a flight visibility of at least 5 kilometres;
- (c) an aircraft flying outside controlled airspace at or above flight level 100 shall remain at least 1500 metres horizontally and 1000 feet vertically away from cloud and in a flight visibility of at least 8 kilometres;
- (d) an aircraft flying outside controlled airspace below flight level 100 shall remain at least 1500 metres horizontally and 1000 feet vertically away from cloud and in a flight visibility of at least 5 kilometres;

Provided that this sub-paragraph shall be deemed to be complied with if:

- (i) the aircraft is flying at or below 3000 feet above mean sea level and remains clear of cloud and in sight of the surface and in a flight visibility of at least 5 kilometres;
- (ii) the aircraft, other than a helicopter, is flying at or below 3000 feet above mean sea level at a speed which according to its air speed indicator is 140 knots or less and remains clear of cloud and in a flight visibility of at least 1500 metres; or
- (iii) in the case of a helicopter, the helicopter is flying at or below 3000 feet above mean sea level flying at a speed, which, having regard to the visibility, is reasonable, and remains clear of cloud and in sight of the surface.

For the purposes of this Rule "Special VFR flight" means a flight made in Instrument Meteorological Conditions or at night in a control zone notified for the purposes of Rule 21 of these Rules in respect of which the appropriate air traffic control unit has given permission for the flight to be made in accordance with special instructions given by that unit instead of in accordance with the Instrument Flight Rules.

23A. VFR Plans and air traffic control clearance

(1) Unless otherwise specified by the appropriate air traffic control unit before an aircraft flies within Class B, Class C or Class D airspace during the notified hours of watch of the appropriate air traffic control unit, the commander of the aircraft shall cause a flight plan to be communicated to the appropriate air traffic control unit and shall obtain an air traffic control clearance to fly within the said airspace.

(2) The flight plan shall contain such particulars of the flight as may be necessary to enable the air traffic control unit to issue a clearance and for search and rescue purposes.

(3) Whilst flying within the said airspace during the notified hours of watch of the appropriate air traffic control unit the commander of the aircraft shall:

- (a) cause a continuous watch to be maintained on the notified radio frequency appropriate

- to the circumstances; and
- (b) comply with any instructions which the appropriate air traffic control unit may give in a particular case.

SECTION VI

INSTRUMENT FLIGHT RULES

24. The Instrument Flight Rules shall be as follows:

- (a) Within controlled airspace:
In relation to flights within controlled airspace Rules 25, 27 and 28 shall apply.
- (b) Outside controlled airspace:
In relation to flights outside controlled airspace Rules 25 and 26 shall apply.

25. Minimum height

Without prejudice to the provisions of Rule 5, in order to comply with the Instrument Flight Rules an aircraft shall not fly at a height of less than 1000 feet above the highest obstacle within a distance of 5 nautical miles of the aircraft unless:

- (a) it is necessary for the aircraft to do so in order to land; or
- (b) the aircraft is flying on a route notified for the purpose of this Rule; or
- (c) the aircraft has been otherwise authorised by the competent authority; or
- (d) the aircraft is flying at an altitude not exceeding 3000 feet above mean sea level and remains clear of cloud and in sight of the surface.

26. Semi-circular Rule

In order to comply with the Instrument Flight Rules, an aircraft when in level flight above 3000 feet above mean sea level or above the appropriate transition altitude, whichever is the higher, shall be flown at a level appropriate to its magnetic track, in accordance with the appropriate Table set forth in this Rule. The level of flight shall be measured by an altimeter set according to the system published by the competent authority in relation to the area over which the aircraft is flying:

Provided that an aircraft may be flown at a level other than the level required by this Rule if it is flying in conformity with instructions given by an air traffic control unit or in accordance with notified en-route holding patterns or in accordance with holding procedures notified in relation to an aerodrome.

For the purposes of this Rule "transition altitude" means the altitude so notified in relation to flight over such area or areas as may be notified.

TABLE I-Flights at levels at or below 24500 feet

| Magnetic Track | Cruising Level |
|---------------------------------------|------------------------|
| Less than 180 degrees | Odd thousands of feet |
| 180 degrees but less than 360 degrees | Even thousands of feet |

TABLE II-Flights at levels above 24500 feet

| Magnetic Track | Cruising Level |
|-----------------------|----------------------------|
| Less than 180 degrees | 25000 feet. 27000 feet. |

180 degrees but less than
360 degrees

29000 feet or higher levels at intervals of
4000 feet.
26000 feet.
28000 feet.
31000 feet or higher levels at intervals of
4000 feet.

27. Flight plan and air traffic control clearance

(1) In order to comply with the Instrument Flight Rules, before an aircraft either takes off from a point within any controlled airspace or otherwise flies within any controlled airspace the commander of the aircraft shall cause a flight plan to be communicated to the appropriate air traffic control unit and shall obtain an air traffic control clearance based on such flight plan.

(2) The flight plan shall contain such particulars of the intended flight as may be necessary to enable the air traffic control unit to issue an air traffic control clearance, or for search and rescue purposes.

(3) The commander of the aircraft shall fly in conformity with-

- (a) the air traffic control clearance issued for the flight, as amended by any further instructions given by an air traffic control unit; and
- (b) the holding and instrument approach procedures notified in relation to the aerodrome of destination, unless he is otherwise authorised by the air traffic control unit there:

Provided that he shall not be required to comply with the foregoing provisions of this paragraph if-

- (i) he is able to fly in uninterrupted Visual Meteorological Conditions for so long as he remains in controlled airspace, and
- (ii) he has informed the appropriate air traffic control unit of his intention to continue the flight in compliance with Visual Flight Rules and has requested that unit to cancel his flight plan.

(4) If for the purpose of avoiding immediate danger any departure is made from the provisions of paragraph (3) of this Rule (as is permitted by Article 64(3) of this Order) the commander of the aircraft shall, in addition to causing particulars to be given in accordance with Article 64(4) of this Order, as soon as possible inform the appropriate air traffic control unit of the deviation.

(5) The commander of the aircraft after he has flown in controlled airspace shall, unless he has requested the appropriate air traffic control unit to cancel his flight plan, forthwith inform that unit when the aircraft lands or leaves the controlled airspace.

28. Position reports

In order to comply with the Instrument Flight Rules the commander of an aircraft in IFR flight who flies in or is intending to enter controlled airspace shall report to the appropriate air traffic control unit the time, and the position and level of the aircraft at such reporting points or at such intervals of time as may be notified for this purpose or as may be directed by the air traffic control unit.

SECTION VII

AERODROME TRAFFIC RULES

29. Application of aerodrome traffic rules

The Rules in this Section of these Rules which are expressed to apply to flying machines shall also be observed, so far as is practicable, in relation to all other aircraft.

30. Visual signals

The commander of a flying machine on, or in the pattern of traffic at, an aerodrome shall observe such visual signals as may be displayed at, or directed to him from, the aerodrome by the authority of the person in charge of the aerodrome and shall obey any instructions which may be given to him by means of such signals:

Provided that he shall not be required to obey the signals referred to in Rule 43 of these Rules (Marshalling Signals) if in his opinion it is inadvisable to do so in the interests of safety.

31. Movement of aircraft on aerodromes

An aircraft shall not taxi on the apron or the manoeuvring area of an aerodrome without the permission of the person in charge of the aerodrome or, where the aerodrome has an air traffic control unit for the time being notified as being on watch, without the permission of that unit.

32. Access to and movement of persons and vehicles on the aerodrome

(1) A person or vehicle shall not go on to any part of an aerodrome (not being a part of the aerodrome which is a public right of way) without the permission of the person in charge of that part of the aerodrome, and except in accordance with any conditions subject to which that permission may have been granted.

(2) A vehicle or person shall not go on to or move on the manoeuvring area of an aerodrome having an air traffic control unit without the permission of that unit, and except in accordance with any conditions subject to which that permission may have been granted.

(3) Any permission granted for the purposes of this Rule may be granted whether in respect of persons or vehicles generally, or in respect of any particular person or vehicle or any class of person or vehicle.

33. Right of way on the ground

- (1) This Rule shall apply to:
- (a) flying machines; and
 - (b) vehicles;

on any part of a land aerodrome provided for the use of aircraft and under the control of the persons in charge of the aerodrome.

(2) Notwithstanding any air traffic control clearance it shall remain the duty of the commander of an aircraft to take all possible measures to ensure that his aircraft does not collide with any other aircraft or with any vehicle.

- (3) (a) Flying machines and vehicles shall give way to aircraft which are taking off or landing.
- (b) Vehicles, and flying machines which are not taking off or landing, shall give way to vehicles towing aircraft.
- (c) Vehicles which are not towing aircraft shall give way to aircraft.

(4) Subject to the provisions of paragraph (3) of this Rule and of Rule 17(7)(c) of these Rules, in case of danger of collision between two flying machines:-

- (a) when the two flying machines are approaching head-on or approximately so, each shall alter its course to the right;
- (b) when the two flying machines are on converging courses, the one which has the other on its right shall give way to the other and shall avoid crossing ahead of the other unless passing well clear of it;
- (c) a flying machine which is being overtaken shall have the right-of-way, and the overtaking flying machine shall keep out of the way of the other flying machine by altering its course to the left until that other machine has been passed and is clear, notwithstanding any change in the relative positions of the two flying machines.

- (5) Subject to the provisions of paragraph (3)(b) of this Rule a vehicle shall-

- (a) overtake another vehicle so that the other vehicle is on the left of the overtaking vehicle;
- (b) keep to the left when passing another vehicle which is approaching head-on or approximately so.

34. Launching, picking up and dropping of tow ropes etc.

(1) Tow ropes, banners or similar articles towed by aircraft shall not be launched at an aerodrome except in accordance with arrangement made with an air traffic control unit at the aerodrome or, if there is not such unit, with person in charge of the aerodrome.

(2) Tow ropes, banners or similar articles towed by aircraft shall not be picked up by or dropped from aircraft at an aerodrome except:-

- (a) in accordance with arrangements with an air traffic control unit at the aerodrome or, if there is no such unit, with the person in charge of the aerodrome; or
- (b) in the area designated by the marking described in Rule 40(7) of these Rules, and the ropes, banners or similar articles shall be picked up and dropped when the aircraft is flying in the direction appropriate for landing.

35. Flight within aerodrome traffic zones

(1) Paragraphs (2) and (3) of this Rule shall apply only in relation to such of the aerodromes described in Column 1 of the following Tables as are notified for the purposes of this Rule and at such times as are specified in Column 2 thereof.

TABLE

| Column 1 | Column 2 |
|---|---|
| (a) A Government aerodrome | at such times as are notified |
| (b) An aerodrome having an air traffic control unit or an aerodrome flight information unit | during the notified hours of watch of the air traffic control unit or the aerodrome flight information unit |
| (c) A licensed aerodrome having a means of two-way radio communication with aircraft | during the notified hours of watch of the air/ground radio |

(2) An aircraft shall not fly, take off or land, within the aerodrome traffic zone of an aerodrome to which this paragraph applies unless the commander of the aircraft has obtained the permission of the air traffic control unit at the aerodrome or, where there is no air traffic control unit, has obtained from the aerodrome flight information unit at that aerodrome information to enable the flight within the zone to be conducted with safety or, where there is no air traffic control unit nor aerodrome flight information unit, has obtained information from the air/ground radio station at that aerodrome to enable the flight to be conducted with safety.

(3) The commander of an aircraft flying within the aerodrome traffic zone of an aerodrome to which this paragraph applies shall:

- (a) cause a continuous watch to be maintained on the appropriate radio frequency notified for communications at the aerodrome or, if this is not possible, cause a watch to be kept for such instructions as may be issued by visual means;
- (b) where the aircraft is fitted with means of communication by radio with the ground, communicate his position and height to the air traffic control unit, the aerodrome flight information unit or the air/ground radio station at the aerodrome (as the case may be), on entering the zone and immediately prior to leaving it.

36. Use of radio navigation aid

The commander of an aircraft shall not make use of any radio navigation aid without complying with such restrictions and appropriate procedures as may be notified in relation to that aid unless authorised by the appropriate air traffic control unit :

Provided that he shall not be required to comply with this Rule if he is required to comply with rule 27 of these Rules.

SECTION VIII

AERODROME SIGNALS AND MARKINGS: VISUAL AND AURAL SIGNALS

37. General

(1) Whenever any signal specified in this Section of these Rules is given or displayed, or whenever any marking so specified is displayed, by any person in an aircraft, or at an aerodrome, or any other place which is being used by aircraft for landing or take-off, it shall, when given or displayed in Hong Kong, have the meaning assigned to it in this Section.

(2) All dimensions specified in this Section of these Rules shall be subject to a tolerance of 10 per cent, plus or minus.

38. Signals in the signals area

(1) When any signal specified in the following paragraphs of this Rule is displayed it shall be placed in a signals area, which shall be a square visible in all directions bordered by a white stripe 30 centimetres wide the internal sides measuring 12 metres.

(2) A white landing T, as illustrated in this paragraph,

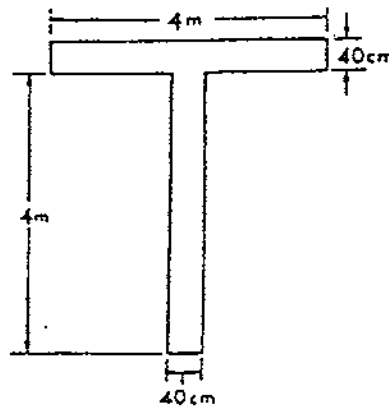

Fig. 1

signifies that aeroplanes and gliders taking off or landing shall do so in a direction parallel with the shaft of the T and towards the cross arm, unless otherwise authorised by the appropriate air traffic control unit.

(3) A white disc 60 centimetres in diameter displayed alongside the cross arm of the T and in line with the shaft of the T, as illustrated in this paragraph,

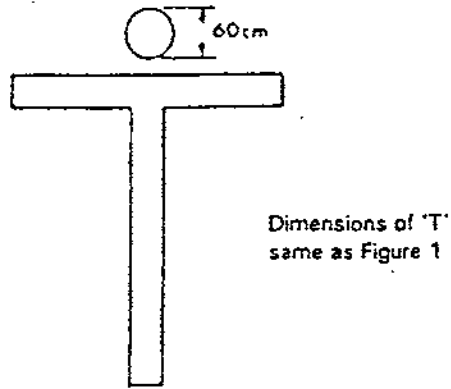

Fig. 2

signifies that the direction of landing and take-off do not necessarily coincide.

(4) A white dumb-bell, as illustrated in this paragraph,

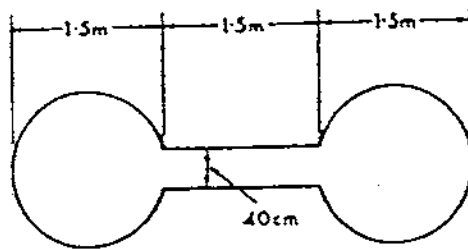

Fig. 3

signifies that movements of aeroplanes and gliders on the ground shall be confined to paved, metallised or similar hard surfaces.

(5) A white dumb-bell as described in (4) above but with a black stripe 60 centimetres wide across each disc at right angles to the shaft of the dumb-bell, as illustrated in this paragraph,

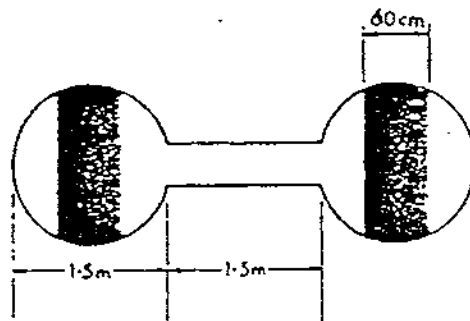

Fig. 4

signifies that aeroplanes and gliders taking off or landing shall do so on a runway but that movement on the ground is not confined to paved, metallised or similar hard surfaces.

(6) A red and yellow striped arrow, as illustrated in this paragraph,

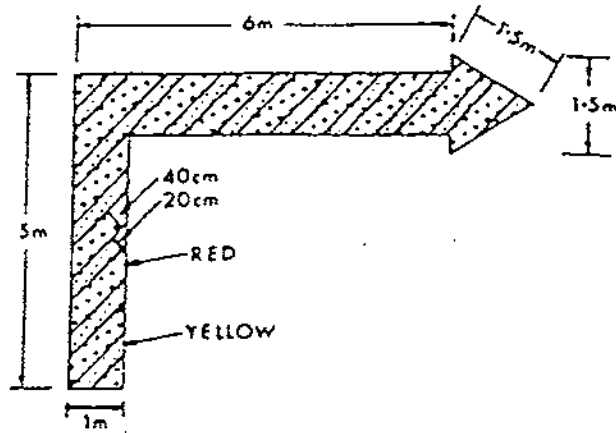

Fig. 5

the shaft of which is at least one metre wide placed along the whole or not less than a total of 11 metres of two adjacent sides of the signals area and pointing in a clockwise direction signifies that a right-hand circuit is in force.

(7) A red panel 3 metres square with a yellow stripe along one diagonal at least 50 centimetres wide, as illustrated in this paragraph,

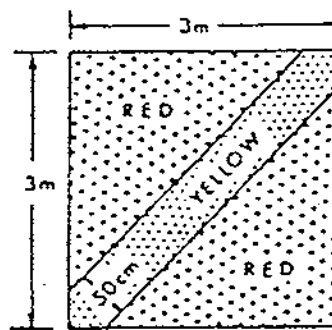
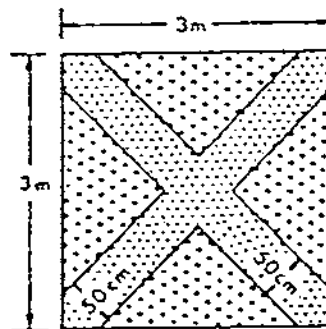

Fig. 6

signifies that the state of the manoeuvring area is poor and pilots must exercise special care when landing.

(8) A red panel 3 metres square with a yellow stripe, at least 50 centimetres wide, along each diagonal, as illustrated in this paragraph,



YELLOW STRIPES ON RED BACKGROUND

Fig. 7

signifies that the aerodrome is unsafe for the movement of aircraft and that landing on the aerodrome is prohibited.

(9) A white letter H, as illustrated in this paragraph,

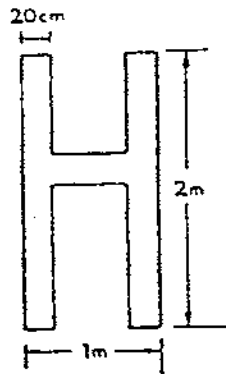

Fig. 8

signifies that helicopters shall take off and land only within the area designated by the marking specified in Rule 40(5) of these Rules.

(10) A red letter L displayed on the dumb-bell specified in paragraphs (4) and (5) of this Rule, as illustrated in this paragraph,

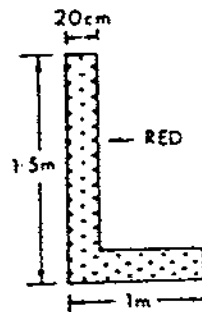

Fig. 9

signifies that light aircraft are permitted to take off and land either on a runway or on the area designated by the marking specified in Rule 40(6) of these Rules.

(11) A white double cross, as illustrated in this paragraph,

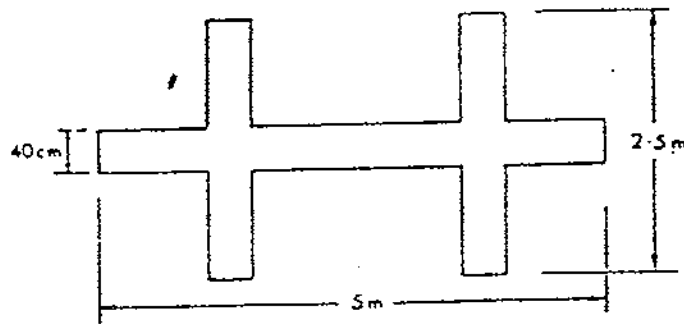

Fig. 10

signifies that glider flying is in progress.

39. Markings for Paved Runways and Taxiways

(1) Two or more white crosses, as illustrated in this paragraph,

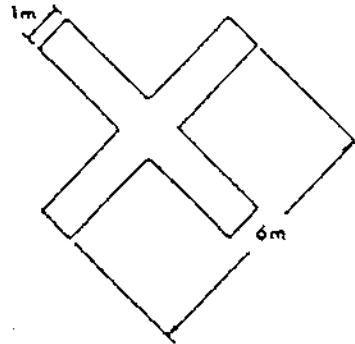

Fig. 11

displayed on a runway or taxiway, with the arms of the crosses at an angle of 45° to the centre line of the runway, at intervals of not more than 300 metres signify that the section of the runway or taxiway marked by them is unfit for the movement of aircraft.

(2) Two white continuous lines or two white broken lines and two continuous lines, as illustrated in this paragraph,

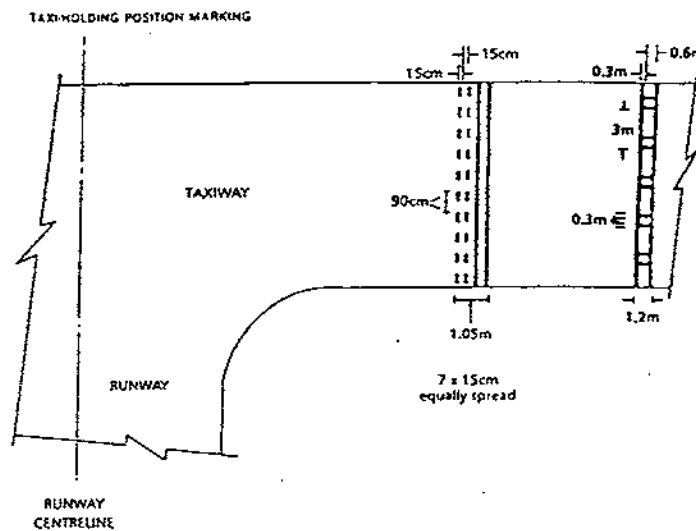

Fig. 12

signify a holding position beyond which no part of an aircraft or vehicle shall project in the direction of the runway without permission from an air traffic control unit.

(3) Orange and white markers, as illustrated in this paragraph,

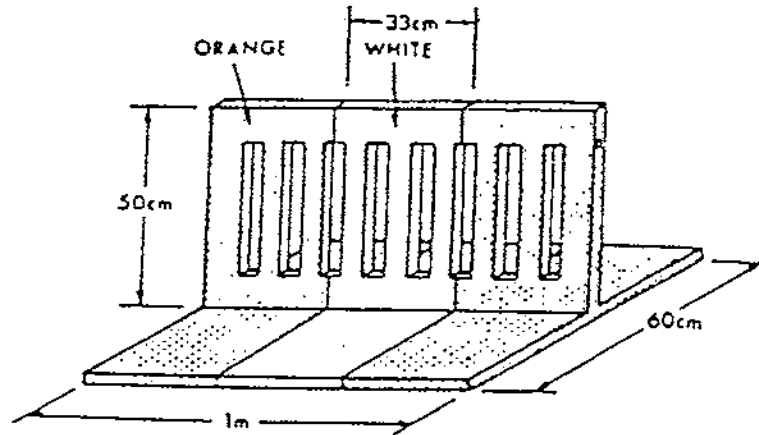

Fig. 13

spaced not more than 15 metres apart, signify the boundary of that part of a paved runway, taxiway or apron which is unfit for the movement of aircraft.

40. Markings on unpaved manoeuvring areas

(1) Markers with orange and white stripes of an equal width of not less than 50 centimetres, with an orange stripe at each end, as illustrated in this paragraph,

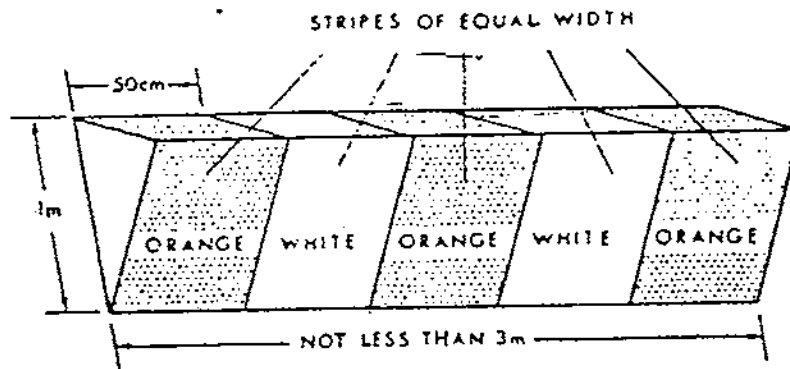

Fig. 14

alternating with flags not less than 60 centimetres square showing equal orange and white triangular areas, indicate the boundary of an area unfit for the movement of aircraft and one or more white crosses as specified in Rule 39(1) of these Rules indicate the said area. The distance between any two successive orange and white flags shall not exceed 90 metres.

(2) Striped markers, as specified in paragraph (1) of this Rule, spaced not more than 45 metres apart, indicate the boundary of an aerodrome.

(3) On structures, markers with orange and white vertical stripes, of an equal width of not less than 50 centimetres, with an orange stripe at each end, as illustrated in this paragraph,

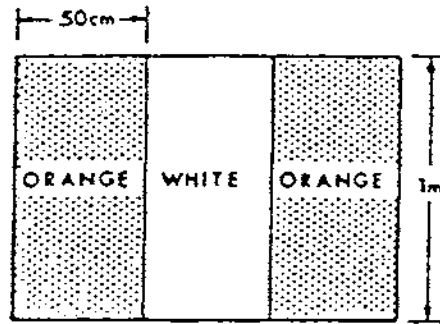

Fig. 15

spaced not more than 45 metres apart, indicate the boundary of an aerodrome. The pattern of the marker shall be visible from inside and outside the aerodrome and the marker shall be affixed not more than 15 centimetres from the top of the structure.

(4) White flat rectangular markers 3 metres long and 1 metres wide at intervals not exceeding 90 metres, flush with the surface of the unpaved runway or stopway, as the case may be, indicate the boundary on an unpaved runway or of a stopway.

(5) A white letter H, as illustrated in this paragraph,

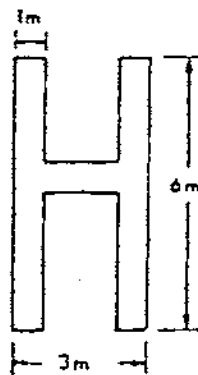

Fig. 16

indicates an area which shall be used only for the taking off and landing of helicopters.

(6) A white letter L, as illustrated in this paragraph,

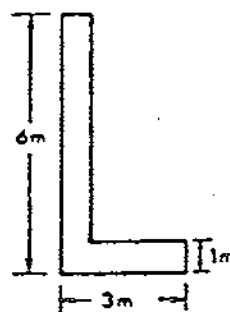

Fig. 17

indicates a part of the manoeuvring area which shall be used only for the taking off and landing of

light aircraft.

(7) A yellow cross with two arms 6 metres long by 1 metre wide at right angles, indicates that tow ropes and similar articles towed by aircraft shall only be picked up and dropped in the area in which the cross is placed.

(8) A white double cross, as illustrated in this paragraph,

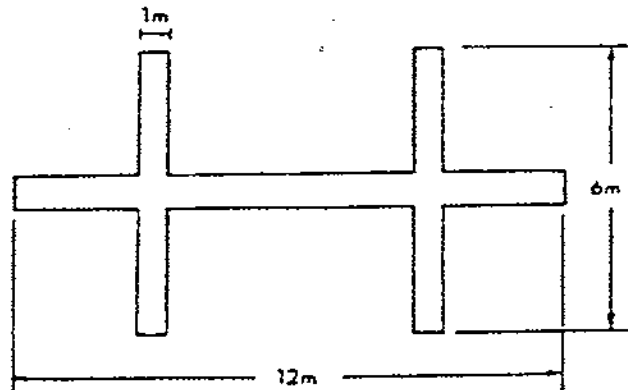

Fig. 18

indicates an area which shall be used only for the taking off and landing of gliders.

(9) A white landing T as specified in Rule 38(2) of these Rules placed at the left hand side of the runway when viewed from the direction of landing indicates the runway to be used, and at an aerodrome with no runway it indicates the direction for take-off and landing.

41. Signals visible from the ground

(1) A black ball 60 centimetres in diameter suspended from a mast signifies that the directions of take-off and landing are not necessarily the same.

(2) A checkered flag or board, 1.2 metres by 90 centimetres containing twelve equal squares, 4 horizontally and 3 vertically, coloured red and yellow alternately, signifies that aircraft may move on the manoeuvring area and apron only in accordance with the permission of the air traffic control unit at the aerodrome.

(3) Two red balls 60 centimetres in diameter, disposed vertically one above the other, 60 centimetres apart and suspended from a mast, signify that glider flying is in progress at the aerodrome.

(4) Black arabic numerals in two-figure groups and, where parallel runways are provided the letter or letters L (left), LC (left centre), C (centre), RC (right centre) and R (right), placed against a yellow background, indicate the direction for take-off for the runway in use.

(5) A black letter C against a yellow background, as illustrated in this paragraph,

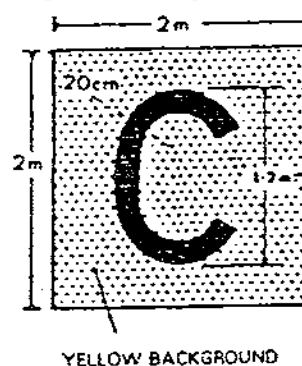

Fig. 19

indicates the position at which a pilot can report to the air traffic control unit or to the person in charge of the aerodrome.

(6) A rectangular green flag of not less than 60 centimetres square flown from a mast indicates that a right hand circuit is in force.

42. Lights and pyrotechnic signals for control of aerodrome traffic

Each signal described in the first column of Table A, when directed from an aerodrome to an aircraft or to a vehicle, or from an aircraft, shall have the meanings respectively appearing in the second, third and fourth columns of that Table opposite the description of the signal.

TABLE A
MEANING OF LIGHTS AND PYROTECHNIC SIGNALS

| | Characteristic and colour of light beam or pyrotechnic | From an aerodrome | | From an aircraft in flight to an aerodrome | | | |
|-----|--|---|--|---|-----------------------------|--------------------|----------------|
| | | to an aircraft in flight | to an aircraft or vehicle on the aerodrome | | | | |
| (a) | Continuous red light | Give way to other aircraft and continue circling. | Stop | - | | | |
| (b) | Red pyrotechnic light, or red flare | Do not land; wait for permission. | - | Immediate assistance is requested. | | | |
| (c) | Red flashes | | Do not land; aerodrome not available for landing. | | Move clear of landing area. | | |
| (d) | Green flashes | Return to aerodrome; wait for permission to land. | To an aircraft: You may move on the manoeuvring area and apron; To a vehicle: You may move on the manoeuvring area. | - | | | |
| (e) | Continuous green light | You may land. | You may take off (not applicable to a vehicle). | - | | | |
| (f) | Continuous green light, or green flashes, or green pyrotechnic light | | | { By night: May I land? { By day: May I land in direction different from that indicated by landing T? { | | | |
| (g) | White flashes | | | | Land at this | Return to starting | I am compelled |



| | | | | |
|-----|---|--|-------------------------|-------------------------|
| | | aerodrome after receiving continuous green light, and then, after receiving green flashes, proceed to the apron. | point on the aerodrome. | to land. |
| (h) | White pyrotechnic lights Switching on and off the navigation lights Switching on and off the landing lights | } } } | | I am compelled to land. |





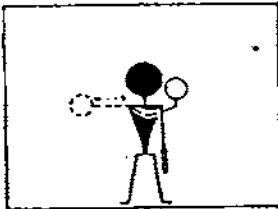
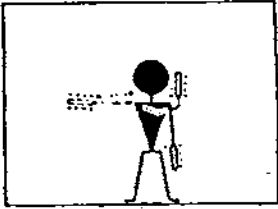
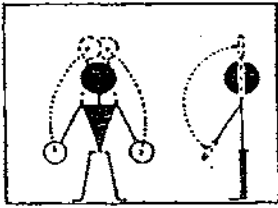
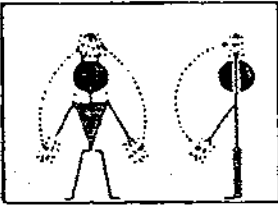
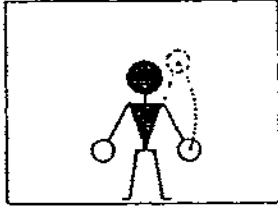

43. Marshalling signals (from a marshaller to an aircraft).

Each of the signals for the guidance of aircraft manoeuvring on or off the ground, described in the first column of Table B, paragraphs (a) to (x) shall, in Hong Kong have the meanings set forth in the second column of that Table opposite the description of the signal. By day any such signals shall be given by hand or by circular bats and by night by torches or illuminated wands.

Table B

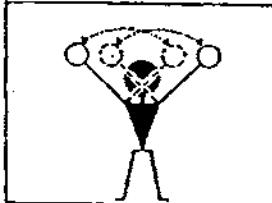
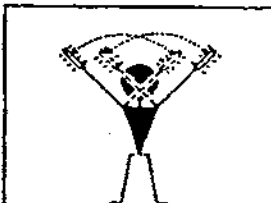
Meaning of marshalling signals (Rule 43)

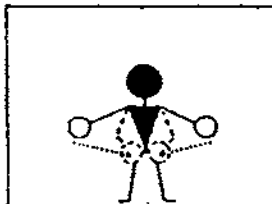
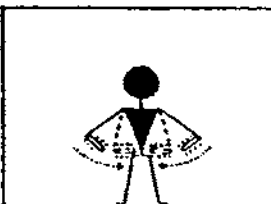
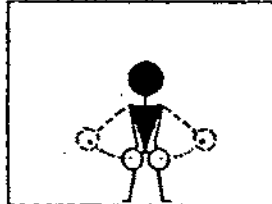
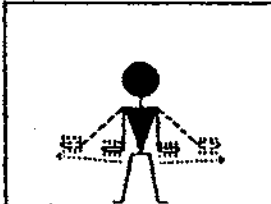
| | Description of signal | Meaning of signal | In daylight | By night |
|-----|--|---|--|---|
| (a) | Right or left arm down, the other arm moved across body and extended to indicate position of the other marshaller. | Proceed under guidance of another marshaller. |  |  |
| (b) | Arms repeatedly moved upward and backward, beckoning onward. | Move ahead. |  |  |
| (c) | Right arm down, left arm repeatedly moved upward and backward. The speed of arm movement | Open up starboard engine or turn to port. |  |  |

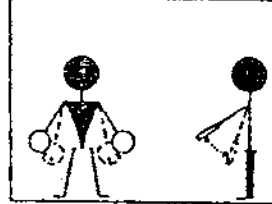
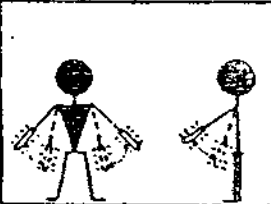
| | | | | |
|-----|--|---|--|---|
| | indicates the rate of turn. | | | |
| (d) | Left arm down, the right arm repeatedly moved upward and backward. The speed of arm movement indicates the rate of turn. | Open up port engine or turn to starboard. |  |  |
| (e) | Arms repeatedly crossed above the head. The speed of arm movement indicates the urgency of the stop. | Stop. |  |  |
| (f) | A circular motion of the right hand at head level, with the left arm pointing to the appropriate engine. | Start engines. |  |  |
| (g) | Arms extended, the palms facing inwards, then swung from the extended position inwards. | Chocks inserted. |  |  |
| (h) | Arms down, the palms facing outwards, then swung outwards. | Chocks away. |  |  |
| (j) | Either arm and hand placed level with the chest, then moved laterally with the palm downwards. | Cut engines. |  |  |
| (k) | Arms placed down, with the palms towards the ground, then moved up and down several times. | Slow down. |  |  |

- (l) Arms placed down, with the palms towards the ground, then either the right or left arm moved, up and down indicating that the motors on the left or right side, as the case may be, should be slowed down.

Slow down engines on indicated side.

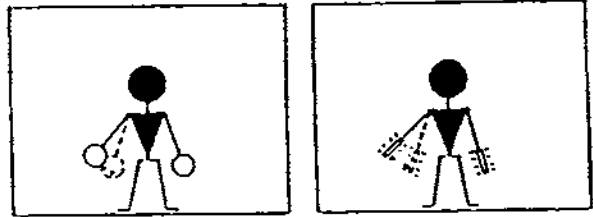

- (m) Arms placed above the head in a vertical position.

This bay.

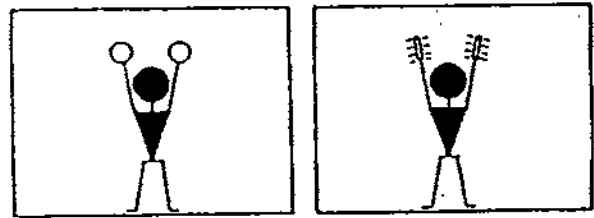

- (n) The right arm raised at the elbow, with the arm facing forward.

All clear: marshalling finished.

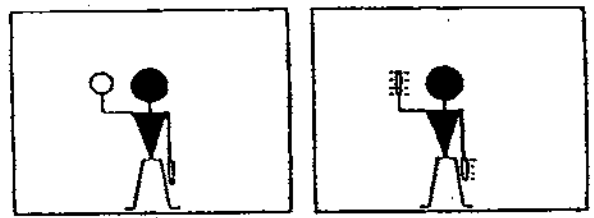

- (o) Arms placed horizontally sideways.

Hover.

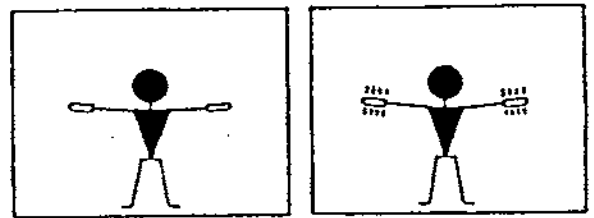

- (p) Arms placed down and crossed in front of the body.

Land.

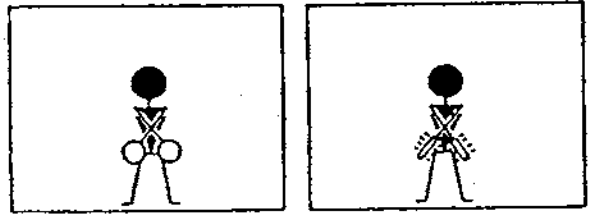

- (q) Arms placed horizontally sideways with the palms up beckoning upwards. The speed of arm movement indicates the rate of ascent.

Move upwards.

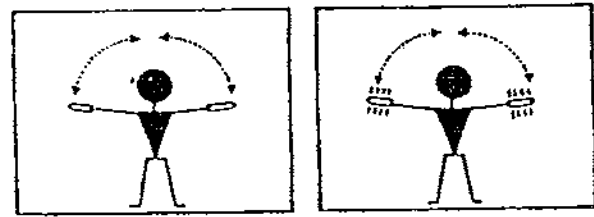

(r) Arms placed horizontally sideways with the palms towards the ground beckoning downwards. The speed of arm movement indicates the rate of descent.

Move downwards.

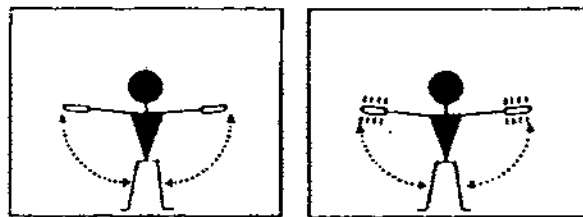

(s) Either arm placed horizontally sideways, then the other arm moved in front of the body to that side, in the direction of the movement, indicating that the helicopter should move horizontally to the left or right side, as the case may be: repeated several times.

Move horizontally.

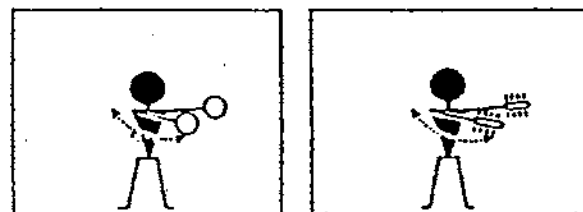
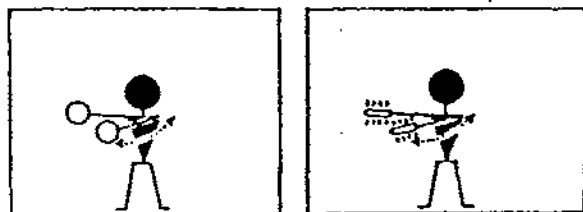

(t) Arms placed down, the palms facing forward, then repeatedly swept up and down to shoulder level.

Move back.

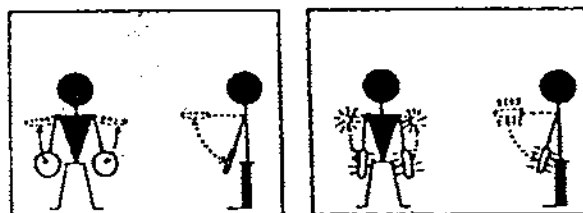

(u) Left arm extended horizontally forward, then right arm making a horizontal slicing movement below left arm.

Release load.



(v) Raise arm, with first clenched, horizontally in front of body, then extend fingers. Release brakes.

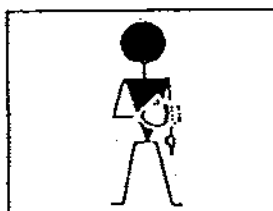

Raise arm and hand, with fingers extended, horizontally in front of body, then clench fist. Engage brakes.



(w) Left hand overhead with the number of fingers extended, to indicate the number of the engine to be started, and circular motion of right hand at head level. Start engine(s).



(x) Point left arm down, move right arm down from overhead, vertical position to horizontal forward position, repeating right arm movement. Back aircraft's tail to starboard.
Point right arm down, move left arm down from overhead, vertical position to horizontal forward position, repeating left arm movement. Back aircraft's tail to port.

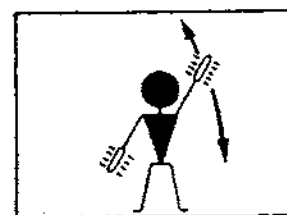
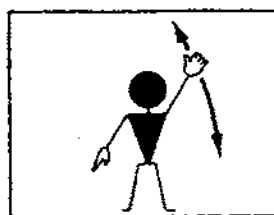

44. Marshalling signals (from a pilot of an aircraft to a marshaller)

The following signals made by a pilot in an aircraft to a marshaller on the ground shall respectively have the following meanings-

| | Description of Signal | Meaning of Signal |
|-----|---|-------------------|
| (a) | Raise arm and hand with fingers extended horizontally in front of face, then clench fist. | Brakes engaged |
| (b) | Raise arm with fist clenched | Brakes released |

- | | | |
|-----|---|------------------------|
| | horizontally in front of face, then extend fingers. | |
| (c) | Arms extended palms facing outwards, move hands inwards to cross in front of face. | Insert chocks |
| (d) | Hands crossed in front of face, palms facing outwards, move arms outwards. | Remove chocks |
| (e) | Raise the number of fingers on one hand indicating the number of the engine to be started. For this purpose the aircraft engines shall be numbered in relation to the marshaller facing the aircraft, from his right to his left for example, No. 1 engine shall be the port outer engine, No. 2 engine shall be the port inner engine, No. 3 engine shall be the starboard inner engine, and No. 4 engine shall be the starboard outer engine. | Ready to start engines |

45. Distress, urgency and safety signals

(1) The following signals, given either together or separately before the sending of a message, signify that an aircraft is threatened by grave and imminent danger and requests immediate assistance-

- (a) by radiotelephony-
the spoken word "MAYDAY";
- (b) visual signalling-
 - (i) the signal SOS (...---...);
 - (ii) a succession of pyrotechnic lights fired at short intervals each showing a single red light;
 - (iii) a parachute flare showing a red light;
- (c) by sound signalling other than radiotelephony-
 - (i) the signal SOS (...---...);
 - (ii) a continuous sounding with any sound apparatus.

(2) The following signals, given either together or separately, before the sending of a message signify that the commander of the aircraft wishes to give notice of difficulties which compel it to land but that he does not require immediate assistance-

- (a) a succession of white pyrotechnic lights;
- (b) the repeated switching on and off of the aircraft landing lights;
- (c) the repeated switching on and off of its navigation lights, in such a manner as to be clearly distinguishable from the flashing navigation lights described in Rule 11 of these Rules.

(3) The following signals, given either together or separately, indicate that the commander of the aircraft has an urgent message to transmit concerning the safety of a ship, aircraft, vehicle or other property or of a person on board or within sight of the aircraft from which the signal is given-

- (a) by radiotelephony-the spoken words "PAN PAN";
- (b) by visual signalling-the signal XXX (-...-...-...-);
- (c) the sound signalling other than radiotelephony-the signal XXX (-...-...-...-).

46. Warning signals to aircraft in flight

In Hong Kong by day or by night, a series of projectiles discharged from the ground at intervals of 10

seconds, each showing, on bursting, red and green lights or stars, shall indicate to the commander of an aircraft that his aircraft is flying in or about to enter an active danger area or an area to which regulations made pursuant to Article 69(1)(a)(iii) of this Order relate and that he is required to take such action as may be necessary to leave the area or change course to avoid the area.

| | | | | |
|-----------|----|---|------------|------------|
| Schedule: | 15 | AIR NAVIGATION (GENERAL) REGULATIONS | 36 of 1999 | 09/07/1999 |
|-----------|----|---|------------|------------|

Remarks:

Adaptation amendments retroactively made - see 36 of 1999 s. 3

Article 9(3)(a)(iii),
11(3) and (6)(a)(iii),
14, 27(1)(c), 28(4),
29(1), 36, 78 and 86(1)

1. Load Sheets

(1) Every load sheet required by Article 28(4) of this Order shall contain the following particulars-

- (a) the nationality and registration mark of the aircraft to which the load sheet relates;
- (b) particulars of the flight to which the load sheet relates;
- (c) the total weight of the aircraft as loaded for that flight;
- (d) the weights of the several items from which the total weight of the aircraft, as so loaded, has been calculated including in particular the weight of the aircraft prepared for service and the respective total weights of the crew (unless included in the weight of the aircraft prepared for service), passengers, baggage and cargo intended to be carried on the flight;
- (e) the manner in which the load is distributed and the resulting position of the centre of gravity of the aircraft which may be given approximately if and to the extent that the relevant certificate of airworthiness so permits,

and shall include a certificate, signed by the person referred in Article 28(1) of this Order as responsible for the loading of the aircraft, that the aircraft has been loaded in accordance with the written instructions furnished to him by the operator of the aircraft pursuant to the said Article 28(1).

- (2) (a) For the purpose of calculating the total weight of the aircraft the respective total weights of the passengers and crew entered in the load sheet shall be computed from the actual weight of each person and for that purpose each person shall be separately weighed;

Provided that, in the case of an aircraft of which the maximum total weight authorised exceeds 5700 kg or which has a total seating capacity authorised by the certificate of airworthiness in force in respect of that aircraft of 12 or more persons, the total weights of the passengers and crew may, subject to the provisions of sub-paragraph (b) of this paragraph and of paragraph (4) of this regulation, be calculated at not less than the appropriate weights shown in Table 1 and the load sheet shall bear a notation to that effect-

Table 1

Males over 12 years of age 75 kg.

Save that on journeys by helicopters in support of or in connection with the exploitation of or exploration for mineral resources (including gas) and-

- (i) between Hong Kong and any vessel or structure located at sea, or
- (ii) between any two such vessels or structures where the last preceding journey from

land or the next subsequent journey to land was from or is intended to be, as the case may be, Hong Kong:

| | |
|---|--------|
| the appropriate weight for male passengers over 12 years shall be | 83 kg. |
| Females over 12 years of age | 65 kg. |
| Children aged 2 years or more, but not over 12 years of age | 39 kg. |
| Infants under 2 years of age | 8 kg. |

- (b) The actual weight of any immersion suit worn or carried by a passenger or crew member shall be added to the appropriate weight shown in Table 1 in each case.
- (c) For the purposes of this regulation, "sea" includes any estuary or arm of the sea.
- (3) (a) For the purpose of calculating the total weight of the aircraft the respective total weights of the baggage and cargo entered in the load sheet shall be computed from the actual weight of each piece of baggage, cargo or cargo container and for that purpose each piece or container shall be separately weighed;

Provided that, in the case of an aeroplane of which the maximum total weight authorised exceeds 5700 kg, or which has a total seating capacity of 12 or more persons, the total weight of the baggage may, subject to the provisions of paragraph (4) of this Regulation, be calculated at not less than the weights shown in Table 2 and the load sheet shall bear a notation to that effect;

| | |
|---------------------------------|------------------------|
| Table 2 | |
| 1 | 2 |
| Cabin baggage per passenger* | Hold baggage per piece |
| 3 kg | 16 kg |

* Not infants under 2 years of age.

- (a) If Table 2 has been used, subject to the provision of paragraph (4) for determining the weight of hold baggage, it shall also be used, subject as aforesaid, for determining the weight of the cabin baggage.
- (4) (a) If it appears to the person supervising the loading of the aircraft that any passenger or baggage to be carried exceeds the weights set out in Table 1 or Table 2 of this Regulation he shall, if he considers it necessary in the interests of the safety of the aircraft, or if the Chief Executive has so directed in the particular case, require any such person or baggage to be weighed for the purpose of the entry to be made in the load sheet. (36 of 1999 s. 3)
- (b) If any person or baggage has been weighed pursuant to sub-paragraph (a) of this paragraph, the weights entered in the load sheet shall take account of the actual weight of that person or baggage, or of the weight determined in accordance with the respective provisos to paragraph (2) or (3), whichever weight shall be the greater.

2. Weight and Performance: General provisions

(1) The assessment of the ability of an aeroplane to comply with the requirement of Regulations 3 to 8 inclusive and of a helicopter to comply with the requirements of Regulations 9 to 11 inclusive (relating, in either case to weight, performance and flights in specified meteorological conditions or at night) shall be based on the specified information as to its performance;

Provided that, in the case of an aeroplane in respect of which there is in force under this Order a certificate of airworthiness which does not include a performance group classification, the assessment may be based on the best information available to the commander of the aircraft, in so far as the relevant information is not specified.

(2) In assessing the ability of an aeroplane to comply with condition (7) in the Annex hereto, conditions (4) and (5) of Regulation 4, and conditions (2)(i)(b) and (2)(ii) of Regulation 8, account may be taken of any reduction of the weight of the aeroplane which may be achieved after the failure of a power unit by such jettisoning of fuel as is feasible and prudent in the circumstances of the flight and in accordance with the flight manual included in the certificate of airworthiness relating to the aircraft.

(3) In Regulations 2 to 11 inclusive, and in the Annex hereto, unless the context otherwise requires-

"specified" in relation to an aircraft means specified in, or ascertainable by reference to-

(a) the certificate of airworthiness in force under this Order in respect of that aircraft; or

(b) the flight manual or performance schedule included in that certificate, or other document, whatever its title, incorporated by reference in that certificate;

"the emergency distance available" means the distance from the point on the surface of the aerodrome at which the aeroplane can commence its take-off run to the nearest point in the direction of take-off at which the aeroplane cannot roll over the surface of the aerodrome and be brought to rest in an emergency without risk of accident;

"the landing distance available" means the distance from the point on the surface of the aerodrome above which the aeroplane can commence its landing, having regard to the obstruction in its approach path, to the nearest point in the direction of landing at which the surface of the aerodrome is incapable of bearing the weight of the aeroplane under normal operating conditions or at which there is an obstacle capable of affecting the safety of the aeroplane;

"the take-off distance available" means either the distance from the point on the surface of the aerodrome at which the aeroplane can commence its take-off run to the nearest obstacle in the direction of take-off projecting above the surface of the aerodrome and capable of affecting the safety of the aeroplane or one and one half times the take-off run available whichever is the less;

"the take-off run available" means the distance from the point on the surface of the aerodrome at which the aeroplane can commence its take-off run to the nearest point in the direction of take-off at which the surface of the aerodrome is incapable of bearing the weight of the aeroplane under normal operating conditions.

(4) For the purposes of Regulations 2 to 8 inclusive, and of the Annex hereto:

(a) the weight of the aeroplane at the commencement of the take-off run shall be taken to be its gross weight including everything and everyone carried in or on it at the commencement of the take-off run;

(b) the landing weight of the aeroplane shall be taken to be the weight of the aeroplane at the estimated time of landing allowing for the weight of the fuel and oil expected to be used on the flight to the aerodrome at which it is intended to land or alternate aerodrome, as the case may be;

(c) where any distance referred to in paragraph (3) of this Regulation has been declared in respect of any aerodrome by the authority responsible for regulating air navigation over the territory of the Contracting State in which the aerodrome is situated and in the case of an aerodrome in Hong Kong notified, that distance shall be deemed to be the relevant distance.

(5) Nothing in Regulations 2 to 11 inclusive shall apply to any aircraft flying solely for the purpose of training persons to perform duties in aircraft.

3. Weight and Performance of Public Transport Aeroplanes having no Performance Group Classification in their Certificates of Airworthiness

With reference to Article 29(1) of this Order an aeroplane registered in Hong Kong in respect of which there is in force under this Order a certificate of airworthiness which does not include a performance group classification shall not fly for the purpose of public transport unless

the weight of the aeroplane at the commencement of the take-off run is such that such of the conditions in the Annex hereto as apply to that aircraft are satisfied.

4. Weight and Performance of Public Transport Aeroplanes
classified as Aeroplanes of Performance Group A in their
Certificates of Airworthiness

With reference to Article 29(1) of this Order an aeroplane registered in Hong Kong in respect of which there is in force under this Order a certificate of airworthiness in which the aeroplane is designated as being of performance group A shall not fly for the purpose of public transport unless the weight of the aeroplane at the commencement of the take-off run is such that the following conditions are satisfied:

(1) That weight does not exceed the maximum take-off weight for altitude and temperature specified for the altitude and the air temperature at the aerodrome at which the take-off is to be made.

(2) The take-off run, take-off distance and the emergency distance respectively required for take-off, specified as being appropriate to-

- (a) the weight of the aeroplane at the commencement of the take-off run;
- (b) the altitude at the aerodrome;
- (c) the air temperature at the aerodrome;
- (d) the condition of the surface of the runway from which the take-off will be made;
- (e) the slope of the surface of the aerodrome in the direction of take-off over the take-off run available, the take-off distance available and the emergency distance available, respectively; and
- (f) not more than 50 per cent of the reported wind component opposite to the direction of take-off or not less than 150 per cent of the reported wind component in the direction of take-off,

do not exceed the take-off run, the take-off distance and the emergency distance available, respectively, at the aerodrome at which the take-off is to be made; in ascertaining the emergency distance required, the point at which the pilot is assumed to decide to discontinue the take-off shall not be nearer to the start of the take-off run than the point at which, in ascertaining the take-off run required and the take-off distance required, he is assumed to decide to continue the take-off, in the event of power unit failure.

(3) (a) The net take-off flight path with one power unit inoperative, specified as being appropriate to:

- (i) the weight of the aeroplane at the commencement of the take-off run;
- (ii) the altitude at the aerodrome;
- (iii) the air temperature at the aerodrome; and
- (iv) not more than 50 per cent of the reported wind component opposite to the direction of take-off or not less than 150 per cent of the reported wind component in the direction of take-off.

and plotted from a point 35 feet or 50 feet, as appropriate, above the end of the take-off distance required at the aerodrome at which the take-off is to be made to a height of 1500 feet above the aerodrome, shows that the aeroplane will clear any obstacle in its path by a vertical interval of at least 35 feet; and if it is intended that the aeroplane shall change its direction of flight by more than 15° the vertical interval shall not be less than 50 feet during the change of direction.

(b) For the purpose of sub-paragraph (a) hereof an obstacle shall be deemed to be in the path of the aeroplane if the distance from the obstacle to the nearest point on the ground below the intended line of flight of the aeroplane does not exceed-

- (i) a distance of 60 metres plus half the wing span of the aeroplane plus one eighth of the distance from such point to the end of the take-off distance available measured along the intended line of flight of the aeroplane; or
- (ii) 900 metres,

whichever is the less.

- (c) In assessing the ability of the aeroplane to satisfy this condition, it shall not be assumed to make a change of direction of a radius less than the specified radius of steady turn.

(4) The aeroplane will, in the meteorological conditions expected for the flight, in the event of any one power unit becoming inoperative at any point on its route or on any planned diversion therefrom and with the other power unit or units operating within the maximum continuous power conditions specified be capable of continuing the flight, clearing by a vertical interval of at least 2000 feet obstacles within 10 nautical miles either side of the intended track to an aerodrome at which it can comply with condition (7) in this Regulation relating to an alternate aerodrome and on arrival over such aerodrome the gradient of the specified net flight path with one power unit inoperative shall not be less than zero at 1500 feet above the aerodrome, and in assessing the ability of the aeroplane to satisfy this condition it shall not be assumed to be capable of flying at an altitude exceeding the specified maximum permissible altitude for power unit restarting:

Provided that where the operator of the aeroplane is satisfied, taking into account the navigation aids which can be made use of by the aeroplane on the route, that the commander of the aeroplane will be able to maintain his intended track on that route within a margin of 5 nautical miles, the foregoing provisions of this paragraph shall have effect as if 5 nautical miles were substituted for 10 nautical miles.

(5) In the case of an aeroplane having three or more power units, it will, in the meteorological conditions expected for the flight, in the event of any two power units becoming inoperative at any point along the route or on any planned diversion therefrom more than 90 minutes flying time in still air at the all power units operating economical cruising speed from the nearest aerodrome at which it can comply with condition (7) in this Regulation, relating to an alternate aerodrome, be capable of continuing the flight with all other power units operating within the specified maximum continuous power conditions, clearing by a vertical interval of at least 2000 feet obstacles within 10 nautical miles either side of the intended track to such an aerodrome, and on arrival over such an aerodrome the gradient of the specified net flight path with two power units inoperative shall not be less than zero at 1500 feet above the aerodrome; and in assessing the ability of the aeroplane to satisfy this condition it shall not be assumed to be capable of flying at an altitude exceeding the specified maximum permissible altitude for power unit restarting:

Provided that where the operator of the aeroplane is satisfied taking into account the navigation aids which can be made use of by the aeroplane on the route, that the commander of the aeroplane will be able to maintain his intended track on the route within a margin of five nautical miles, the foregoing provisions of this paragraph shall have effect as if five nautical miles were substituted for 10 nautical miles; or

In the case of an aeroplane having two power units and a maximum total weight authorized which exceeds 5700 kg, and which is not limited by its certificate of airworthiness to the carriage of less than 20 passengers, it will, in the meteorological conditions expected for the flight, at any point along the route or on any planned diversion therefrom, not be more than 60 minutes flying time at the normal one engine inoperative cruise speed in still air from the nearest aerodrome at which it can comply with condition (7) in this Regulation, relating to an alternate aerodrome, unless it is flying under and in accordance with the terms of any written permission granted by the Chief Executive to the operator under this regulation; or (36 of 1999 s. 3)

In the case of an aeroplane having two power units and a maximum total weight authorized 5700 kg, or less or in the case of an aeroplane having two power units and a maximum total weight authorized of more than 5700 kg, but which is limited by its certificate of airworthiness to the carriage of less than 20 passengers the aeroplane will, in the meteorological conditions expected for the flight, not be more than 90 minutes flying time in still air at the all power units operating economical cruising speed from the nearest aerodrome at which it can comply with condition (7) in this regulation, relating to an alternate aerodrome.

(6) The landing weight of the aeroplane will not exceed the maximum landing weight specified for the altitude and the expected air temperature for the estimated time of landing at the aerodrome at which it is intended to land and at any alternate aerodrome.

- (7) (a) (i) In the case of a turbine-jet powered aeroplane, the landing distance required does not exceed at the aerodrome at which it is intended to land or at any

alternate aerodrome, as the case may be, the landing distance available on-

- (aa) the most suitable runway for a landing in still air conditions; and
- (bb) the runway that may be required for landing because of the forecast wind conditions.

(ii) In the case of an aeroplane powered by turbine propeller or piston engines, the landing distances required, respectively specified as being appropriate to aerodromes of destination and alternate aerodromes, do not exceed at the aerodrome at which it is intended to land or at any alternate aerodrome, as the case may be, the landing distance available on-

- (aa) the most suitable runway for a landing in still air conditions; and
- (bb) the runway that may be required for landing because of the forecast wind conditions:

Provided that if an alternate aerodrome is designated in the flight plan, the specified landing distance required may be that appropriate to an alternate aerodrome when assessing the ability of the aeroplane to satisfy this condition at the aerodrome of destination.

- (b) For the purposes of sub-paragraph (a) hereof the landing distance required shall be that specified as being appropriate to-
- (i) the landing weight;
 - (ii) the altitude at the aerodrome;
 - (iii) the temperature in the specified international standard atmosphere appropriate to the altitude at the aerodrome;
 - (iv) (aa) a level surface in the case of runways usable in both directions;
(bb) the average slope of the runway in the case of runways usable in only one direction; and
 - (v) (aa) still air conditions in the case of the most suitable runway for a landing in still air conditions;
(bb) not more than 50 per cent of the forecast wind component opposite to the direction of landing in the case of the runway that may be required for landing because of the forecast wind conditions.

5. Weight and Performance of Public Transport Aeroplanes
classified as Aeroplanes of Performance Group C
in their Certificate of Airworthiness

With reference to Article 29(1) of this Order an aeroplane registered in Hong Kong in respect of which there is in force under this Order a certificate of airworthiness in which the aeroplane is designated as being of performance group C shall not fly for the purpose of public transport unless the weight of the aeroplane at the commencement of the take-off run is such that the following conditions are satisfied-

(1) That weight does not exceed the maximum take-off weight specified for the altitude and the air temperature at the aerodrome at which the take-off is to be made.

(2) The take-off run required and the take-off distance required, specified as being appropriate to-

- (a) the weight of the aeroplane at the commencement of the take-off run;
- (b) the altitude of the aerodrome;
- (c) the air temperature at the aerodrome;
- (d) the average slope of the surface of the aerodrome in the direction of take-off over the emergency distance available; and
- (e) not more than 50 per cent of the reported wind component opposite to the direction of take-off or not less than 150 per cent of the reported wind component in the direction of take-off, do not exceed the take-off run available and the emergency distance available, respectively, at the aerodrome at which the take-off is to be made.

(3) (a) Subject to condition (4) of this Regulation, the net take-off flight path with all

power units operating specified as being appropriate to-

- (i) the weight of the aeroplane at the commencement of the take-off run;
- (ii) the altitude at the aerodrome;
- (iii) the air temperature at the aerodrome;
- (iv) not more than 50 per cent of the reported wind component opposite to the direction of take-off or not less than 150 per cent of the reported wind component in the direction of take-off;

and plotted from a point 50 feet above the end of the take-off distance required at the aerodrome at which the take-off is to be made to a height of 1500 feet above the aerodrome shows that the aeroplane will clear any obstacle in its path by a vertical interval of not less than 35 feet; and if it is intended that the aeroplane shall change its direction of flight by more than 15° before reaching 1500 feet the vertical interval shall be not less than 50 feet while the aircraft is changing direction.

- (b) For the purpose of sub-paragraph (a) hereof an obstacle shall be deemed to be in the path of the aeroplane if the distance from the obstacle to the nearest point on the ground below the intended line of flight of the aeroplane does not exceed 75 metres.
 - (c) In assessing the ability of the aeroplane to satisfy this condition, it shall not be assumed to make a change of direction of a radius less than the specified radius of steady turn.
- (4) (a) In the case of an aeroplane which is intended to be flown for any period before reaching a height of 1500 feet above the aerodrome from which the take-off is to be made in conditions which will not ensure that any obstacles can be located by means of visual observation, the net take-off flight path with one power unit inoperative specified as being appropriate to the factors contained in sub-paragraphs (i) to (iv) of condition 3(a) in this Regulation and plotted from the point on the net take-off flight path with all power units operating specified as being appropriate to those factors at which in the meteorological conditions expected for the flight the loss of visual reference would occur, shows that the aeroplane will clear by a vertical interval of not less than 35 feet any obstacle in its path; and if it is intended that the aeroplane shall change its direction of flight by more than 15° the vertical interval shall not be less than 50 feet during the change of direction.
- (b) For the purpose of sub-paragraph (a) hereof an obstacle shall be deemed to be in the path of the aeroplane if the distance from the obstacle to the nearest point on the ground below the intended line of flight of the aeroplane does not exceed-
 - (i) 75 metres plus one eighth of the distance from such point to the end of the emergency distance available measured along the intended line of flight of the aeroplane; or
 - (ii) 900 metres,

whichever is the less.

- (c) In assessing the ability of the aerodrome to satisfy this condition it shall not be assumed to make a change of direction of a radius less than the specified radius of steady turn.

(5) The aeroplane at any time after it reaches a height of 1500 feet above the aerodrome from which the take-off is made will, in the meteorological conditions expected for the flight, in the event of any one power unit becoming inoperative at any point on its route or on any planned diversion therefrom, and with the other power unit or power units operating within the specified maximum continuous power conditions, be capable of continuing the flight at altitudes not less than the relevant minimum altitude for safe flight stated in, or calculated from the information contained in, the operations manual relating to the aeroplane to a point 1500 feet above an aerodrome at which a safe landing can be made and after arrival at that point be capable of maintaining that height:

Provided that in assessing the ability of the aeroplane to satisfy this condition it shall not be assumed to be capable of flying at any point on its route at an altitude exceeding the performance ceiling, with all power units operating, specified as being appropriate to its estimated weight at that point.

(6) The landing weight of the aeroplane will not exceed the maximum landing weight specified for the altitude and the expected air temperature for the estimated time of landing at the aerodrome at which it is intended to land and at any alternate aerodrome.

(7) Subject to condition (8) of this Regulation, the distance required by the aeroplane to land from a height of 50 feet otherwise than in accordance with specified data for short field landing does not, at the aerodrome at which it is intended to land and at any alternate aerodrome, exceed 70 per cent of the landing distance available on the most suitable runway for a landing in still air conditions, and on the runway that may be required for landing because of the forecast wind conditions; and for the purposes of this condition the distance required to land from a height of 50 feet shall be taken to be that specified as being appropriate to-

- (a) the landing weight;
- (b) the altitude at the aerodrome;
- (c) the temperature in the specified international standard atmosphere appropriate to the altitude at the aerodrome;
- (d) (i) a level surface in the case of runways usable in both directions;
(ii) the average slope of the runway in the case of runways usable in only one direction; and
- (e) (i) still air conditions in the case of the most suitable runway for landing in still air conditions;
(ii) not more than 50 per cent of the forecast wind component opposite to the direction of landing or not less than 150 per cent of the forecast wind component in the direction of landing in the case of the runway that may be required for landing because of the forecast wind conditions.

(8) As an alternative to condition (7) of this Regulation, the distance required by the aeroplane, with all power units operating and with one power unit inoperative, to land in accordance with specified data for short field landing, does not at the aerodrome of intended destination and at any alternate aerodrome exceed the landing distance available on the most suitable runway for a landing in still air conditions and on the runway that may be required for landing because of the forecast wind conditions; and for the purpose of this condition the distance required to land from the appropriate heights shall be taken to be that specified as being appropriate to the factors set forth in sub-paragraphs (a) to (e) of condition (7) of this Regulation and the appropriate height shall be-

- (a) for a landing with all power units operating-any height between 30 and 50 feet in Hong Kong and 50 feet elsewhere; and
- (b) for a landing with one power unit inoperative-50 feet in Hong Kong and elsewhere:
Provided that-
 - (i) if the specified distance required to land with one power unit inoperative from a height of 50 feet at the aerodrome of intended destination exceeds the landing distance available, it shall be sufficient compliance with sub-paragraph (b) of this condition if an alternate aerodrome which has available the specified landing distance required to land with one power unit inoperative from such a height, is designated in the flight plan;
 - (ii) the distance required by the aeroplane to land shall be determined in accordance with condition (7) and not in accordance with this condition if it is intended to land at night, or when the cloud ceiling or ground visibility forecast for the estimated time of landing at the aerodrome of intended destination and at any alternate aerodrome at which it is intended to land in accordance with specified data for short field landing with all power units operating are less than 500 feet and one nautical mile respectively.

6. Weight and Performance of Public Transport Aeroplanes
classified as Aeroplanes of Performance Group D
in their Certificate of Airworthiness

With reference to Article 29(1) of this Order an aeroplane registered in Hong Kong in respect

of which there is in force under this Order a certificate of airworthiness in which the aeroplane is designated as being of performance group D shall not fly for the purpose of public transport at night or when the cloud ceiling or visibility prevailing at the aerodrome of departure and forecast for the estimated time of landing at the aerodrome at which it is intended to land and at any alternate aerodrome are less than 1000 feet and one nautical mile respectively and shall not fly for the purpose of public transport at any other time unless the weight of the aeroplane at the commencement of the take-off run is such that the following conditions are satisfied-

(1) That weight does not exceed the maximum take-off weight specified for the altitude and air temperature at the aerodrome at which the take-off is to be made.

(2) The take-off run required and the take-off distance required specified as being appropriate to-

- (a) the weight of the aeroplane at the commencement of the take-off run;
- (b) the altitude at the aerodrome;
- (c) the air temperature at the aerodrome;
- (d) the average slope of the surface of the aerodrome in the direction of take-off over the emergency distance available; and
- (e) not more than 50 per cent of the reported wind component opposite to the direction of take-off or not less than 150 per cent of the reported wind component in the direction of take-off.

(3) (a) The net take-off flight path with all power units operating, specified as being appropriate to-

- (i) the weight of the aeroplane at the commencement of the take-off run;
- (ii) the altitude at the aerodrome;
- (iii) the air temperature at the aerodrome; and
- (iv) not more than 50 per cent of the reported wind component opposite to the direction of take-off or not less than 150 per cent of the reported wind component in the direction of take-off, and plotted from a point 50 feet above the end of the take-off distance required at the aerodrome at which the take-off is to be made to the point at which the aeroplane reaches a height of 1000 feet above the aerodrome shows that the aeroplane will clear any obstacle in its path by a vertical interval of not less than 35 feet except that if it is intended that the aeroplane shall change its direction of flight by more than 15° before reaching 1000 feet the vertical interval shall be not less than 50 feet while the aircraft is changing direction.

(b) For the purpose of sub-paragraph (a) hereof an obstacle shall be deemed to be in the path of the aeroplane if the distance from the obstacle to the nearest point on the ground below the intended line of flight of the aeroplane does not exceed 75 metres.

(c) In assessing the ability of the aeroplane to satisfy this condition it shall not be assumed to make a change of direction of a radius less than the specified radius of steady turn.

(4) The aeroplane, at any time after it reaches a height of 1000 feet above the aerodrome from which take-off is to be made, will, in the meteorological conditions expected for the flight, in the event of any one power unit becoming inoperative at any point on its route or on any planned diversion therefrom, and with the other power unit or power units, if any, operating within the maximum specified continuous power conditions, be capable of continuing the flight at altitudes not less than the relevant minimum altitudes for safe flight stated in, or calculated from the information contained in, the operations manual relating to the aeroplane to a point 1000 feet above a place at which a safe landing can be made:

Provided that in assessing the ability of the aeroplane to satisfy this condition it shall not be assumed to be capable of flying at any point on its route at an altitude exceeding the performance ceiling with all power units operating specified as being appropriate to its estimated weight at that point.

(5) The landing weight of the aeroplane will not exceed the maximum landing weight specified for the altitude and the expected air temperature for the estimated time of landing at the

aerodrome at which it is intended to land and at any alternate aerodrome.

(6) The distance required by the aeroplane to land from a height of 50 feet does not, at the aerodrome at which it is intended to land and at any alternate aerodrome, exceed 70 per cent of the landing distance available on the most suitable runway for a landing in still air conditions, and on the runway that may be required for landing because of the forecast wind conditions; and for the purposes of a runway that may be required for this condition the distance required to land from a height of 50 feet shall be taken to be that specified as being appropriate to-

- (a) the landing weight;
- (b) the altitude at the aerodrome;
- (c) the temperature in the specified international standard atmosphere appropriate to the altitude at the aerodrome;
- (d) (i) a level surface in the case of runways usable in both directions;
(ii) the average slope of the runway in the case of runways usable in only one direction; and
- (e) (i) still air conditions in the case of the most suitable runway for a landing in still air conditions;

(ii) not more than 50 per cent of the forecast wind component opposite to the direction of landing or not less than 150 per cent of the forecast wind component in the direction of landing in the case of the runway that may be required for landing because of the forecast wind conditions.

7. Weight and Performance of Public Transport Aeroplanes
classified as Aeroplanes of Performance Group E
in their Certificates of Airworthiness

(1) With reference to Article 29(1) of this Order an aeroplane registered in Hong Kong in respect of which there is in force under this Order a certificate of airworthiness in which the aeroplane is designated as being of performance group E shall not fly for the purpose of public transport unless the weight of the aeroplane at the commencement of the take-off run is such that the following conditions are satisfied-

- (a) that weight for the altitude and the air temperature at the aerodrome at which the take-off is to be made does not exceed the maximum take-off weight specified as being appropriate to-
 - (i) the weight at which the aeroplane is capable in the en-route configuration and with all power units operating within the specified maximum continuous power conditions of a rate of climb of 700 feet per minute if it has retractable landing gear and of 500 feet per minute if it has fixed landing gear; and
 - (ii) the weight at which the aeroplane is capable, in the en-route configuration and if it is necessary for it to be flown solely by reference to instruments for any period before reaching the minimum altitude for safe flight on the first stage of the route to be flown, stated in, or calculated from the information contained in, the operations manual relating to the aeroplane and, with one power unit inoperative, of a rate of climb of 150 feet per minute.
- (b) The distance required by the aeroplane to attain a height of 50 feet, with all power units operating within the maximum take-off power conditions specified, when multiplied by a factor of 1.33 does not exceed the emergency distance available at the aerodrome at which the take-off is to be made. The distance required by the aeroplane to attain a height of 50 feet shall be that appropriate to-
 - (i) the weight of the aeroplane at the commencement of the take-off run;
 - (ii) the altitude at the aerodrome;
 - (iii) the air temperature at the aerodrome; and
 - (iv) not more than 50 per cent of the reported wind component opposite to the direction of take-off or not less than 150 per cent of the reported wind component in the direction of take-off.
- (c) The aeroplane will, in the meteorological conditions expected for the flight, in the

event of any one power unit becoming inoperative at any point on its route or on any planned diversion therefrom, and with the other power unit or power units, if any, operating within the specified maximum continuous power conditions, be capable of continuing the flight at altitudes not less than the relevant minimum altitude for safe flight stated in, or calculated from the information contained in, the operations manual to a point 1000 feet above a place at which a safe landing can be made:

Provided that in assessing the ability of the aeroplane to satisfy this condition it shall not be assumed to be capable of flying at any point on its route or on any planned diversion therefrom at an altitude exceeding that at which it is capable of a rate of climb with all power units operating within the maximum continuous power conditions specified of 150 feet per minute and if it is necessary for it to be flown solely by reference to instruments, be capable with one power unit inoperative, of a rate of climb of 100 feet per minute.

- (d) The landing weight of the aeroplane for the altitude and the expected air temperature for the estimated time of landing at the aerodrome at which it is intended to land and at any alternate aerodrome will not exceed the maximum landing weight specified-
 - (i) at which the aeroplane is capable, in the en-route configuration and with all power units operating within the specified maximum continuous power conditions of a rate of climb of 700 feet per minute if it has retractable landing gear and of 500 feet per minute if it has fixed landing gear; and
 - (ii) at which the aeroplane is capable in the en-route configuration and if it is necessary for it to be flown solely by reference to instruments for any period after leaving the minimum altitude for safe flight on the last stage of the route to be flown, stated in, or calculated from the information contained in, the operations manual relating to the aeroplane and with one power unit inoperative, of a rate of climb of 150 feet per minute.

(2) An aeroplane designated as aforesaid as an aeroplane of performance group E shall not fly for the purpose of public transport at night or when the cloud ceiling or visibility prevailing at the aerodrome of departure and forecast for the estimated time of landing at the aerodrome at which it is intended to land and at any alternate aerodrome are less than 1000 feet and one nautical mile respectively:

Provided that the foregoing prohibition shall not apply if the aeroplane is capable, in the en-route configuration and with one power unit inoperative, of a rate of climb of 150 feet per minute.

8. Weight and Performance of Public Transport Aeroplanes classified as Aeroplanes of Performance Group X in their Certificates of Airworthiness

With reference to Article 29(1) of this Order an aeroplane in respect of which there is in force under this Order a certificate of airworthiness designating the aeroplane as being of performance group X shall not fly for the purpose of public transport unless the weight of the aeroplane at the commencement of the take-off run is such that the following conditions are satisfied:

- (1) (i) That weight does not exceed the maximum take-off weight specified for the altitude at the aerodrome at which the take-off is to be made, or for the altitude and the air temperature at such aerodrome, as the case may be.
- (ii) The minimum effective take-off runway length required specified as being appropriate to-
 - (a) the weight of the aeroplane at the commencement of the take-off run;
 - (b) the altitude at the aerodrome;
 - (c) the air temperature at the time of take-off;
 - (d) the condition of the surface of the runway from which the take-off will be made;
 - (e) the overall slope of the take-off run available; and

- (f) not more than 50 per cent of the reported wind component opposite to the direction of take-off or not less than 150 per cent of the reported wind component in the direction of take-off,
does not exceed the take-off run available at the aerodrome at which the take-off is to be made.
- (iii) (a) The take-off flight path with one power unit inoperative, specified as being appropriate to-
- (aa) the weight of the aeroplane at the commencement of the take-off run;
 - (bb) the altitude at the aerodrome; and
 - (cc) not more than 50 per cent of the reported wind component opposite to the direction of take-off or not less than 150 per cent of the reported wind component in the direction of take-off,
- and plotted from a point 50 feet above the end of the minimum effective take-off runway length required at the aerodrome at which the take-off is to be made, shows that the aeroplane will thereafter clear any obstacle in its path by a vertical interval of not less than the greater of 50 feet or 35 feet plus one-hundredth of the distance from the point on the ground below the intended line of flight of the aeroplane nearest to the obstacle to the end of the take-off distance available, measured along the intended line of flight of the aeroplane.
- (b) For the purpose of sub-paragraph (a) an obstacle shall be deemed to be in the path of the aeroplane if the distance from the obstacle to the nearest point on the ground below the intended line of flight does not exceed-
- (aa) a distance of 60 metres plus half the wing span of the aeroplane plus one-eighth of the distance from such point to the end of the take-off distance available measured along the intended line of flight; or
 - (bb) 900 metres,
- whichever is the less.
- (c) In assessing the ability of the aeroplane to satisfy this condition, insofar as it relates to flight path, it shall not be assumed to make a change of direction of a radius less than the radius of steady turn corresponding to an angle of bank of 15°.
- (2) (i) (a) Subject to sub-paragraph (b), the weight of the aeroplane at any point on the route or any planned diversion therefrom, having regard to the fuel and oil expected to be consumed up to that point, shall be such that the aeroplane with one power unit inoperative and the other power unit or units operating within the maximum continuous power conditions specified, will be capable of a rate of climb of at least $K(V_{so}/100)^2$ feet per minute at an altitude not less than the minimum altitude for safe flight stated in or calculated from the information contained in the operations manual where V_{so} is in knots and K has the value of $797-1060/N$, N being the number of power units installed.
- (b) As an alternative to (a) the aeroplane may be flown at an altitude from which, in the event of failure of one power unit, it is capable of reaching an aerodrome where a landing can be made in accordance with condition (3)(ii) in this Regulation relating to an alternate aerodrome. In that case the weight of the aeroplane shall be such that, with the remaining power unit or units operating within the maximum continuous power conditions specified, it is capable of maintaining a minimum altitude on the route to such aerodrome of 2000 feet above all obstacles within 10 nautical miles on either side of the intended track:

Provided that where the operator of the aeroplane is satisfied, taking into account the navigation aids which can be made use of by aeroplane on the route that the commander of the aeroplane will be able to maintain his intended track on that route within a margin of 5 nautical miles, the foregoing provisions of this sub-paragraph shall have effect as if 5 nautical miles were

substituted therein for 10 nautical miles and

- (aa) the rate of climb, specified for the appropriate weight and altitude, used in calculating the flight path shall be reduced by an amount equal to $K(V_{so}/100)^2$ feet per minute;
 - (bb) the aeroplane shall with the climb requirements of condition (2)(i)(a) at 1000 feet above the chosen aerodrome;
 - (cc) account shall be taken of the effect of wind and temperature on the flight path; and
 - (dd) the weight of the aeroplane may be assumed to be progressively reduced by normal consumption of fuel and oil.
- (ii) An aeroplane having four power units shall, if any two power units become inoperative at any point along the route or any planned diversion therefrom, being a point more than 90 minutes flying time (assuming all power units to be operating) from the nearest aerodrome at which a landing can be made in compliance with condition (3)(ii) of this Regulation relating to an alternate aerodrome be capable of continuing the flight at an altitude of not less than 1000 feet above ground level to a point above that aerodrome. In assessing the ability of the aeroplane to satisfy this condition, it shall be assumed that the remaining power units will operate within the specified maximum continuous power conditions, and account shall be taken of the temperature and wind conditions expected for the flight.
- (3) (i) The landing weight of the aeroplane will not exceed the maximum landing weight specified for the altitude at the aerodrome at which it is intended to land and at any alternate aerodrome.
- (ii) The required landing runway lengths respectively specified as being appropriate to the aerodromes of intended destination and the alternate aerodromes do not exceed at the aerodrome at which it is intended to land or at any alternate aerodrome, as the case may be, the landing distance available on-
- (a) the most suitable runway for landing in still air conditions; and
 - (b) the runway that may be required for landing because of the forecast wind conditions,
- the required landing runway lengths being taken to be those specified as being appropriate to-
- (aa) the landing weight;
 - (bb) the altitude at the aerodrome;
 - (cc) still air conditions in the case of the most suitable runway for a landing in still air conditions; and
 - (dd) not more than 50 per cent of the forecast wind component opposite to the direction of landing or not less than 150 per cent of the forecast wind component in the direction of landing in the case of the runway that may be required for landing because of the forecast wind conditions.

9. Weight and Performance of Public Transport Helicopter classified as Helicopters of Performance Group A in their Certificate of Airworthiness

With reference to Article 29(1) of this Order a helicopter registered in Hong Kong in respect of which there is in force under the Order a Certificate of Airworthiness in which the helicopter is designated as being of performance Group A shall not fly for the purpose of public transport unless the weight of the helicopter at the commencement of take-off is such that the following conditions are satisfied:

(1) The weight does not exceed the maximum take-off weight specified for the altitude and the air temperature at the site from which the take-off is to be made.

(2) The landing weight of the helicopter will not exceed the maximum landing weight specified for the altitude and the expected air temperature for the estimated time of landing at the

site at which it is intended to land and at any alternate site.

10. Weight and Performance of Public Transport Helicopter classified as helicopters of Performance Group A (Restricted) in their Certificate of Airworthiness

With reference to Article 29(1), a helicopter registered in Hong Kong in respect of which there is in force under the Order a certificate of airworthiness in which the helicopter is designated as being of performance group A (restricted) shall not fly for the purpose of public transport when the cloud ceiling or visibility prevailing at the departure site and forecast for the estimated time of landing at the site at which it is intended to land and at any alternate site are less than 500 feet and 1000 metres respectively and shall not fly for the purpose of public transport at any other time unless the weight of the helicopter at the commencement of take off is such that the following conditions are satisfied:

(1) The weight does not exceed the maximum take-off weight specified for the altitude and the air temperature at the site from which the take-off is to be made.

(2) The landing weight of the helicopter will not exceed the maximum landing weight specified for the altitude and the expected air temperature for the estimated time of landing at the site at which it is intended to land and at any alternate site.

11. Weight and Performance of Public Transport Helicopters classified as Helicopters of Performance Group B in their Certificate of Airworthiness

With reference to Article 29(1) of this Order a helicopter registered in Hong Kong in respect of which there is in force under this Order a Certificate of Airworthiness in which the helicopter is designated as being of performance Group B shall not fly for the purpose of public transport at night or out of sight of the surface or when the cloud ceiling or visibility prevailing at the departure site and forecast for the estimated time of landing at the site at which it is intended to land are less than 600 feet and 1000 metres respectively and shall not fly for the purpose of public transport at any other time unless the weight of the helicopter at the commencement of take-off is such that the following conditions are satisfied:

(1) The weight does not exceed the maximum take-off weight specified for the altitude and the air temperature at the site at which the take-off is to be made.

(2) The landing weight of the helicopter will not exceed the maximum landing weight specified for the altitude and the expected air temperature for the estimated time of landing at the site at which it is intended to land and at any alternate site.

12. Noise and Vibration caused by Aircraft on Aerodromes

With reference to Article 78 of this Order, the conditions under which noise and vibration may be caused by aircraft (including military aircraft) on Government aerodromes, licensed aerodromes or on aerodromes at which the manufacture, repair or maintenance of aircraft is carried out by persons carrying on business as manufacturers or repairers of aircraft, shall be as follows, that is to say, that, whether in the course of the manufacture of the aircraft or otherwise-

- (a) the aircraft is taking off or landing; or
- (b) the aircraft is moving on the ground or water; or
- (c) the engines are being operated in the aircraft-
 - (i) for the purpose of ensuring their satisfactory performance;
 - (ii) for the purpose of bringing them to a proper temperature in preparation for, or at the end of, a flight; or
 - (iii) for the purpose of ensuring that the instruments, accessories or other components of the aircraft are in a satisfactory condition.

13. (Repealed 36 of 1999 s. 3)

14. Aeroplanes flying for the Purpose of Public Transport of Passengers-Aerodrome Facilities for Approach to Landing and Landing

(1) This Regulation shall apply to every aeroplane registered in Hong Kong engaging on a flight for the purpose of the public transport of passengers on a scheduled journey and to every aeroplane so registered whose maximum total weight authorised exceeds 5700 kg engaging on such a flight otherwise than on a scheduled journey.

(2) For the purposes of Article 27(1)(c) of this Order, the following manning and equipment are prescribed in relation to aerodromes intended to be used for landing or as an alternate aerodrome by aircraft to which this Regulation applies-

- (a) air traffic control service or aerodrome flight information service, including the reporting to aircraft of the current meteorological conditions at the aerodrome;
- (b) very high frequency radiotelephony;
- (c) at least one of the following radio navigation aids, either at the aerodrome or elsewhere, and in either case for the purpose of assisting the pilot in locating the aerodrome and making an approach to landing there-
 - (i) radio direction finding equipment utilizing emissions in the very high frequency bands;
 - (ii) a non-directional radio beacon transmitting signals in the low or medium frequency bands;
 - (iii) very high frequency omni-directional radio range;
 - (iv) radar equipment.

It shall be sufficient if the equipment specified in sub-paragraph (c) is provided, even if for the time being it is not in operation.

(3) An aircraft to which this Regulation applies shall not land or make an approach to landing at any aerodrome unless services and equipment according with paragraph (2) of this Regulation are provided and are in operation at that aerodrome, and can be made use of by that aircraft, and, in the case of the navigation aids specified in sub-paragraph (c), items (i) to (iv), instructions and procedures for the use of the aid are included in the operations manual. A person shall be deemed not to have contravened the provisions of this paragraph if he proves that-

- (a) for the time being use could not be made of the radio navigation aids provided under paragraph (2)(c) whether by reason of those aids not being in operation or of the unserviceability of equipment in the aircraft itself; and
- (b) the approach to landing was made in accordance with instructions and procedures appropriate to that circumstance and included in the operations manual.

(4) An aircraft to which this Regulation applies shall be equipped with the equipment necessary to enable use to be made of at least one of the navigation aids specified in paragraph 2(c) of this Regulation and in use for landing at the aerodrome. Nothing in this paragraph shall require the duplication of any equipment carried in pursuance of any other provision of this Order of any regulation made thereunder.

15. Pilot Maintenance-Prescribed Repair or Replacements

With reference to Article 11(3) of this Order the following repairs or replacements are hereby prescribed-

(1) Repairs to upholstery and decorative furnishing of the cabin or cockpit interior when repair does not require dismantling of any structure or operating system or interfere with an operating system or affect the structure of the aircraft;

(2) Replacement of seats or seat parts not involving dismantling of any structure or of any operating system.

16. Mandatory Reporting-Prescribed Reportable Occurrences, Time and Manner of Reporting and Information to be reported

(1) With reference to Article 86(1) of this Order, the following reportable occurrences are hereby prescribed, that is to say those-

- (a) involving damage to an aircraft;
 - (b) involving injury to a person;
 - (c) involving the impairment during a flight of the capacity of a member of the flight crew of an aircraft to undertake the functions to which his licence relates;
 - (d) involving the use in flight of any procedures taken for the purpose of overcoming an emergency;
 - (e) involving the failure of an aircraft system or of any equipment of an aircraft;
 - (f) arising from the control of an aircraft in flight by its flight crew;
 - (g) arising from failure or inadequacy of facilities or services on the ground used or intended to be used for purposes of or in connection with the operation of aircraft;
 - (h) arising from the loading or the carriage of passengers, cargo (including mail) or fuel;
- and those which are not referred to in sub-paragraphs (a) to (h) of this paragraph of this Regulation but which, in the opinion of a person referred to in sub-paragraphs (a) to (e) of Article 86(1) of this Order, constitute an occurrence endangering, or which if not corrected would endanger, the safety of an aircraft, its occupants or any other person.

(2) For the purposes of this Regulation, an aircraft system includes the flight control, power plant, fuel, hydraulic, pneumatic, pressurization, electrical, navigation and any other system of the aircraft.

(3) With reference to Article 86(1) of this Order, it is hereby prescribed that a report containing the information referred to in paragraph (4) of this Regulation shall be despatched in writing and by the quickest available means to the Chief Executive within 96 hours of the reportable occurrence coming to the knowledge of the person making the report:

Provided that, if at that time any of the said information is not in the possession of that person, he shall despatch that information to the Chief Executive in writing and by the quickest available means within 96 hours of it coming into his possession. (36 of 1999 s. 3)

(4) With reference to Article 86(1) of this Order, a report shall, as far as possible, contain the following information:

- (a) the type, series and registration marks of the aircraft concerned;
- (b) the name of the operator of the aircraft;
- (c) the date of the reportable occurrence;
- (d) if the person making the report has instituted an investigation into the reportable occurrence, whether or not this has been completed;
- (e) a description of the reportable occurrence, including its effects and any other relevant information;
- (f) in the case of a reportable occurrence which occurs during flight-
 - (i) the Co-ordinated Universal Time of the occurrence; (36 of 1999 s. 3)
 - (ii) the last point of departure and the next point of intended landing of the aircraft at that time;
 - (iii) the geographical position of the aircraft at that time;
- (g) in the case of a defect in or malfunctioning of an aircraft or any part or equipment of an aircraft, the name of the manufacturer of the aircraft, part or equipment, as the case may be, and, where appropriate, the part number and modification standard of the part or equipment and its location on the aircraft;
- (h) the signature and name in block capitals of the person making the report, the name of his employer and the capacity in which he acts for that employer;
- (i) in the case of a report made by the commander of an aircraft or a person referred to in sub-paragraph (c) or (d) of Article 86(1) of this Order the address or telephone number at which communications should be made to him, if different from that of his place of employment.

17. Minimum Navigation Performance Specifications-
Prescribed Airspace and Navigation
Performance Capability

(1) With reference to Article 36 of this Order the following navigation performance capability is hereby prescribed, that is to say, a capability to ensure that-

- (a) the standard deviation of lateral errors in the track of the aircraft is not more than 6.3 nautical miles; and
- (b) the proportion of the flight time of the aircraft during which the actual track of the aircraft is 30 nautical miles or more off the track along which it has been given an air traffic control clearance to fly is less than 5.3×10^{-4} ; and
- (c) the proportion of the flight time of the aircraft during which the actual track of the aircraft is between 50 and 70 nautical miles off the track along which it has been given an air traffic control clearance to fly is less than 13×10^{-5} .

(2) For the purposes of Article 36 of this Order the following airspace is hereby prescribed, that is to say, the airspace from flight level 275 to flight level 400 within the area defined by rhumb lines joining successively the following points-

| | |
|-----------------|-----------------|
| 34°10'N 17°48'W | 65°00'N 60°00'W |
| 36°30'N 15°00'W | 64°00'N 63°00'W |
| 42°00'N 15°00'W | 61°00'N 63°00'W |
| 43°00'N 13°00'W | 57°00'N 59°00'W |
| 45°00'N 13°00'W | 53°00'N 54°00'W |
| 45°00'N 08°00'W | 49°00'N 51°00'W |
| 51°00'N 08°00'W | 45°00'N 51°00'W |
| 51°00'N 15°00'W | 45°00'N 53°00'W |
| 54°00'N 15°00'W | 43°36'N 60°00'W |
| 54°34'N 10°00'W | 41°52'N 67°00'W |
| 61°00'N 10°00'W | 39°00'N 67°00'W |
| 61°00'N 00°00' | 38°35'N 68°53'W |
| 82°00'N 00°00' | 38°30'N 69°15'W |
| 82°00'N 30°00'E | 38°30'N 60°00'W |
| North Pole | 27°00'N 60°00'W |
| 82°00'N 60°00'W | 27°00'N 25°00'W |
| 78°00'N 75°00'W | 30°00'N 25°00'W |
| 76°00'N 76°00'W | 30°00'N 20°00'W |
| 65°00'N 76°45'W | 31°39'N 17°25'W |

thence by that part of the arc of a circle radius 100 nautical miles centred on 33°04'N 16°21'W to,
34°10'N 17°48'W

ANNEX TO SCHEDULE 15

Regulation 3

WEIGHT AND PERFORMANCE OF PUBLIC TRANSPORT AEROPLANES
HAVING NO PERFORMANCE GROUP CLASSIFICATION IN THEIR
CERTIFICATE OF AIRWORTHINESS

Conditions (1) and (2) apply to all aeroplanes to which Regulation 3 applies;

Conditions (3) to (10) apply to all aeroplanes to which Regulation 3 applies;

- (i) of which the specified maximum total weight authorized exceeds 5700 kg, or
- (ii) of which the specified maximum total weight authorized does not exceed 5700 kg and which comply with neither condition (1)(a) nor condition (1)(b);

Conditions (11) to (18) inclusive apply to all aeroplanes to which Regulation 3 applies of which the specified maximum total weight authorized does not exceed 5700 kg and which comply with condition (1)(a) or condition (1)(b) or with both those conditions.

All aeroplanes

- (1) Either-
 - (a) the wing loading of the aeroplane does not exceed 20 lb per square foot; or
 - (b) the stalling speed of the aeroplane in the landing configuration does not exceed 60 knots; or
 - (c) the aeroplane, with any one of its power units inoperative and the remaining power unit or units operating within the maximum continuous power conditions specified, is capable of a gradient of climb of at least 1 in 200 at an altitude of 5000 feet in the specified international standard atmosphere.

(2) The weight of the aeroplane at the commencement of the take-off run does not exceed the maximum take-off weight, if any, specified for the altitude and the air temperature at the aerodrome at which the take-off is to be made.

Aeroplanes of a specified maximum total weight authorized exceeding 5700 kg and aeroplanes of a specified maximum total weight authorized not exceeding 5700 kg which comply with neither condition (1)(a) nor condition (1)(b).

- (3) (a) The distance required by the aeroplane to attain a height of 50 feet, with all power units operating within the maximum take-off power conditions specified, does not exceed the take-off run available at the aerodrome at which the take-off is to be made.
- (b) The distance required by the aeroplane to attain a height of 50 feet with all power units operating within the maximum take-off power conditions specified, when multiplied by a factor of either 1.33 for aeroplanes having two power units or by a factor of 1.18 for aeroplanes having four power units, does not exceed the emergency distance available at the aerodrome at which the take-off is to be made.
- (c) For the purposes of sub-paragraphs (a) and (b) the distance required by the aeroplane to attain a height of 50 feet shall be that appropriate to-
 - (i) the weight of the aeroplane at the commencement of the take-off run;
 - (ii) the altitude at the aerodrome;
 - (iii) the air temperature at the aerodrome;
 - (iv) the condition of the surface of the runway from which the take-off will be made;
 - (v) the slope of the surface of the aerodrome in the direction of take-off over the take-off run available and the emergency distance available, respectively; and
 - (vi) not more than 50 per cent of the reported wind component opposite to the direction of take-off or not less than 150 per cent of the reported wind component in the direction of take-off.
- (4) (a) The take-off flight path with one power unit inoperative and the remaining power unit or units operating within the maximum take-off power conditions specified, appropriate to-
 - (i) the weight of the aeroplane at the commencement of the take-off run;
 - (ii) the altitude at the aerodrome;
 - (iii) the air temperature at the aerodrome;

- (iv) not more than 50 per cent of the reported wind component opposite to the direction of take-off or not less than 150 per cent of the reported wind component in the direction of take-off,

and plotted from a point 50 feet above the end of the appropriate factored distance required for take-off under condition (3)(b) of this Annex at the aerodrome at which the take-off is to be made, shows that the aeroplane will clear any obstacle in its path by a vertical interval of at least 35 feet except that if it is intended that an aeroplane shall change its direction by more than 15° the vertical interval shall be not less than 50 feet during the change of direction.

- (b) For the purpose of sub-paragraph (4)(a) an obstacle shall be deemed to be in the path of the aeroplane if the distance from the obstacle to the nearest point on the ground below the intended line of flight does not exceed-
 - (i) a distance of 60 metres plus half the wing span of the aeroplane, plus one-eighth of the distance from such point to the end of the take-off distance available, measured along the intended line of flight; or
 - (ii) 900 metreswhichever is the less
- (c) In assessing the ability of the aeroplane to satisfy this condition, it shall not be assumed to make a change of direction of a radius less than a radius of steady turn corresponding to an angle of bank of 15° .

(5) The aeroplane will, in the meteorological conditions expected for the flight, in the event of any one power unit becoming inoperative at any point on its route or on any planned diversion therefrom and with the other power unit or units operating within the maximum continuous power conditions specified, be capable of continuing the flight clearing obstacles within 10 nautical miles either side of the intended track by a vertical interval of at least-

- (a) 1000 feet when the gradient of the flight path is not less than zero; or

- (b) 2000 feet when the gradient of the flight path is less than zero,

to an aerodrome at which it can comply with condition (9), and on arrival over such aerodrome the flight path shall have a gradient of not less than zero at 1500 feet above the aerodrome.

For the purpose of this condition the gradient of climb of the aeroplane shall be taken to be one per cent less than that specified.

(6) The aeroplane will, in the meteorological conditions expected for the flight, at any point on its route or on any planned diversion therefrom, be capable of climbing at a gradient of at least 1 in 50, with all power units operating within the maximum continuous power conditions, specified at the following altitudes-

- (a) the minimum altitudes for safe flight on each stage of the route to be flown or of any planned diversion therefrom specified in, or calculated from the information contained in, the operations manual relating to the aeroplane; and

- (b) the minimum altitudes necessary for compliance with conditions (5) and (7), as appropriate.

(7) If, on the route to be flown or any planned diversion therefrom, the aeroplane will be engaged in a flight over water during which at any point it may be more than 90 minutes flying time in still air from the nearest shore, it will in the event of two power units becoming inoperative during such time and with the other power unit or units operating within the maximum continuous power conditions specified be capable of continuing the flight having regard to the meteorological conditions expected for the flight, clearing all obstacles within 10 nautical miles either side of the intended track by a vertical interval of at least 1000 feet, to an aerodrome at which a safe landing can be made.

(8) The landing weight of the aeroplane will not exceed the maximum landing weight, if any, specified for the altitude and the expected air temperature for the estimated time of landing at the aerodrome at which it is intended to land and at any alternate aerodrome.

(9) The distance required by the aeroplane to land from a height of 50 feet does not, at the aerodrome at which it is intended to land, exceed 60 per cent of the landing distance available on-

- (i) the most suitable runway for a landing in still air conditions; and

- (ii) the runway that may be required for landing because of the forecast wind conditions; provided that if an alternative aerodrome is designated in the flight plan the landing distance required at the aerodrome at which it is intended to land shall not exceed 70 per cent of that available on the runway.

The distance required to land from a height of 50 feet shall be taken to be that appropriate to-

- (a) the landing weight;
- (b) the altitude at the aerodrome;
- (c) the temperature in the specified international standard atmosphere appropriate to the altitude at the aerodrome;
- (d) (i) a level surface in the case of runways usable in both directions;
(ii) the average slope of the runway in the case of runways usable in only one direction; and
- (e) (i) still air conditions in the case of the most suitable runway for a landing in still air conditions; and
(ii) not more than 50 per cent of the forecast wind component opposite to the direction of landing or not less than 150 per cent of the forecast wind component in the direction of landing in the case of the runway that may be required for landing because of the forecast wind conditions.

(10) The distance required by the aeroplane to land from a height of 50 feet does not, at any alternate aerodrome, exceed 70 per cent of the landing distance available on-

- (i) the most suitable runway for a landing in still air conditions; and
- (ii) the runway that may be required for landing because of the forecast wind conditions.

For the purpose of these conditions the distance required to land from a height of 50 feet shall be determined in the manner provided in condition (9).

Aeroplanes of a specified maximum total weight authorized not exceeding 5700 kg and which comply with either condition (1)(a) or condition (1)(b), or with both these conditions.

(11) If the aeroplane is engaged in a flight at night or when the cloud ceiling or visibility prevailing at the aerodrome of departure and forecast for the estimated time of landing at the aerodrome of destination or at any alternate aerodrome are less than 1000 feet and one nautical mile respectively, it will, with any one of its power units inoperative and the remaining power unit or units operating within the maximum continuous power conditions specified, be capable of climbing at a gradient of at least 1 in 200 at an altitude of 2500 feet in the specified international standard atmosphere.

- (12) (a) The distance required by the aeroplane to attain a height of 50 feet, with all power units operating within the maximum take-off power conditions specified, does not exceed the take-off run available at the aerodrome at which the take-off is to be made;
- (b) The distance required by the aeroplane to attain a height of 50 feet, with all power units operating within the maximum take-off power conditions specified, when multiplied by a factor of 1.33 does not exceed the emergency distance available at the aerodrome at which the take-off is to be made;
- (c) For the purposes of sub-paragraphs (a) and (b) the distance required by the aeroplane to attain a height of 50 feet shall be that appropriate to-
 - (i) the weight of the aeroplane at the commencement of the take-off run;
 - (ii) the altitude at the aerodrome;
 - (iii) the temperature in the specified international standard atmosphere appropriate to the altitude at the aerodrome or, if greater, the air temperature at the aerodrome less 15° centigrade;
 - (iv) the slope of the surface of the aerodrome in the direction of take-off over the take-off run available and the emergency distance available respectively; and
 - (v) not more than 50 per cent of the reported wind component opposite to the direction of take-off or not less than 150 per cent of the reported wind

component in the direction of take-off.

(13) The take-off flight path, with all power units operating within the maximum take-off power conditions specified, appropriate to-

- (i) the weight of the aeroplane at the commencement of the take-off run;
- (ii) the altitude at the aerodrome;
- (iii) the temperature in the specified international standard atmosphere appropriate to the altitude at the aerodrome, or, if greater, the air temperature at the aerodrome less 15° centigrade; and
- (iv) not more than 50 per cent of the reported wind component opposite to the direction of take-off or not less than 150 per cent of the reported wind component in the direction of take-off, and plotted from a point 50 feet above the end of the factored distance required for take-off under condition (12)(b), at the aerodrome at which the take-off is to be made, shows that the aeroplane will clear any obstacle lying within 60 metres plus half the wing span of the aeroplane on either side of its path by a vertical interval of at least 35 feet. In assessing the ability of the aeroplane to satisfy this condition it shall not be assumed to make a change of direction of a radius less than a radius of steady turn corresponding to an angle of bank of 15°.

(14) The aeroplane will, in the meteorological conditions expected for the flight, in the event of any one power unit becoming inoperative at any point on its route or on any planned diversion therefrom and with the other power unit or units, if any, operating within the maximum continuous power conditions specified, be capable of continuing the flight so as to reach a point above a place at which a safe landing can be made at a suitable height for such landing.

(15) The aeroplane will, in the meteorological conditions expected for the flight, at any point on its route or any planned diversion therefrom, be capable of climbing at a gradient of at least 1 in 50, with all power units operating within the maximum continuous power conditions specified at the following altitudes-

- (a) the minimum altitudes for safe flight on each stage of the route to be flown or on any planned diversion therefrom specified in, or calculated from, the information contained in the operations manual relating to the aeroplane; and
- (b) the minimum altitudes necessary for compliance with condition (14).

(16) If on the route to be flown or any planned diversion therefrom the aeroplane will be engaged in a flight over water during which at any point it may be more than 30 minutes flying time in still air from the nearest shore, it will, in the event of one power unit becoming inoperative during such time and with the other power unit or units operating within the maximum continuous power conditions specified, be capable of climbing at a gradient of at least 1 in 200 at an altitude of 5000 feet in the specified international standard atmosphere.

(17) The landing weight of the aeroplane will not exceed the maximum landing weight, if any, specified for the altitude and the expected air temperature for the estimated time of landing at the aerodrome at which it is intended to land and at any alternate aerodrome.

(18) The distance required by the aeroplane to land from a height of 50 feet does not at the aerodrome at which it is intended to land and at any alternate aerodrome exceed 70 per cent, or, if a visual approach and landing will be possible in the meteorological conditions forecast for the estimated time of landing, 80 per cent of the landing distance available on-

- (i) the most suitable runway for a landing in still air conditions; and
- (ii) the runway that may be required for landing because of the forecast wind conditions.

The distance required to land from a height of 50 feet shall be taken to be that appropriate to-

- (a) the landing weight;
- (b) the altitude at the aerodrome;
- (c) the temperature in the specified international standard atmosphere appropriate to the altitude at the aerodrome;
- (d) (i) a level surface in the case of runways usable in both directions;
(ii) the average slope of the runway in the case of runways usable in only one direction; and
- (e) (i) still air conditions in the case of the most suitable runway for a landing in still

air conditions;

(ii) not more than 50 per cent of the forecast wind component opposite to the direction of landing or not less than 150 per cent of the forecast wind component in the direction of landing in the case of the runway that may be required for landing because of the forecast wind conditions.

| | | | | |
|-----------|----|--|------------------|------------|
| Schedule: | 16 | THE AIR NAVIGATION (DANGEROUS GOODS) REGULATIONS | L.N. 195 of 2007 | 01/01/2008 |
|-----------|----|--|------------------|------------|

Article 44

1. Citation

These Regulations may be cited as the Air Navigation (Dangerous Goods) Regulations.

2. Interpretation

(1) In these Regulations:-

"appropriate authority" means any authority designated, or otherwise recognized by a State concerned to perform specific functions related to provisions contained in the Technical Instructions; (L.N. 179 of 1999)

"consignment" means one or more packages of dangerous goods accepted by an operator from one shipper at one time and at one address receipted for in one lot and moving to one consignee at one destination address;

"dangerous goods" means any article or substance which-

(a) is capable of posing a risk to health, safety, property or the environment; and

(b) is-

(i) classified as dangerous goods according to Part 2 of the Technical Instructions; or

(ii) shown in the list of dangerous goods in Part 3 of the Technical Instructions; (L.N. 214 of 2003)

"dangerous goods transport document" means a document, not being an air waybill, which is required by Regulation 4 of these Regulations to accompany a consignment of dangerous goods;

"package" means the packaging and the articles and substances contained therein including one or more packages which have been consolidated by one shipper into one container or enclosure for convenience in handling;

"packing" means the art and operation whereby articles and substances are wrapped up, enclosed in containers or otherwise secured, and "packed" shall be construed accordingly;

"States concerned" has the same meaning as it has in Chapter 1.1.2 of Part 1 of the Technical Instructions; (L.N. 179 of 1999; L.N. 234 of 2001)

"Technical Instructions" means the 2007-2008 English language edition of the Technical Instructions for the Safe Transport of Dangerous Goods by Air approved and published by decision of the Council of the International Civil Aviation Organization; (L.N. 150 of 1997; L.N. 179 of 1999; L.N. 234 of 2001; L.N. 214 of 2003; L.N. 74 of 2006; L.N. 195 of 2007)

"unit load device" means any type of freight container including any container designed for loading on an aircraft.

(2) For the avoidance of doubt, any instructions or limitations contained in the Technical Instructions for the carriage of dangerous goods on passenger or cargo aircraft, as therein defined, shall for the purpose of these Regulations be interpreted as applying also to the carriage of such goods beneath passenger or cargo aircraft respectively.

3. Carriage of dangerous goods

(1) An aircraft shall not carry or have loaded therein or suspended thereunder any dangerous goods, unless such goods are carried, loaded or suspended;

- (a) with the written permission of the Chief Executive and in accordance with any conditions to which such permission may be subject; and (36 of 1999 s. 3)
- (b) in accordance with the Technical Instructions and any conditions specified therein.

(2) A person shall not-

- (a) take or cause to be taken on board,
- (b) suspend or cause to be suspended beneath, or
- (c) deliver or cause to be delivered for loading on or suspension beneath (L.N. 179 of 1999)

an aircraft any goods which he knows or ought to know or suspect to be dangerous goods, unless the provisions of these Regulations are complied with. (L.N. 214 of 2003)

(3) These Regulations shall not apply to dangerous goods carried on an aircraft where the dangerous goods are-

- (a) articles and equipment which are-
 - (i) required to be carried on the aircraft by or under this Order; or
 - (ii) otherwise intended for use on the aircraft for the purpose of the good order of the flight in accordance with normal practice, whether or not such articles and equipment are required to be carried or intended to be used on that particular flight;
- (b) solely intended for the use of, or for sale to, the passengers, flight crew members or cabin crew members of the aircraft during the flight;
- (c) subject to paragraphs (3A), (3B), (3C) and (3D), placed on board with the approval of the operator of the aircraft to provide medical aid to a patient during the flight;
- (d) subject to paragraphs (3A), (3C) and (3D), to provide veterinary aid or a humane killer for an animal during the flight;
- (e) subject to paragraphs (3A), (3C) and (3D), for dropping in connection with agricultural, horticultural, forestry or pollution control activities;
- (f) subject to paragraphs (3A), (3C) and (3D), to provide aid in connection with search and rescue operations during the flight;
- (g) subject to paragraphs (3A) and (3E), vehicles carried in an aircraft designed or modified for vehicle ferry operations;
- (h) subject to paragraph (3A), required for the operation of the specialized equipment of the aircraft during the flight;
- (i) of a type specified in Chapter 2.2.1 of Part 1 of the Technical Instructions;
- (j) of a type specified in Chapter 1.1.2 of Part 8 of the Technical Instructions. (L.N. 195 of 2007)

(3A) Dangerous goods specified in paragraph (3)(c), (d), (e), (f), (g) and (h) shall only be carried if they are under the control of trained personnel when they are in use on the aircraft. (L.N. 195 of 2007)

(3B) Dangerous goods specified in paragraph (3)(c)-

- (a) which is in the form of gas contained in a gas cylinder shall only be carried if the gas cylinder has been manufactured specifically for the purpose of containing and transporting that particular gas; or
- (b) which is an electrolyte in a wet cell battery contained in any equipment shall only be carried if the equipment is kept and, when necessary, secured in an upright position to prevent spillage of the electrolyte. (L.N. 195 of 2007)

(3C) Dangerous goods specified in paragraph (3)(c), (d), (e) and (f) shall only be carried if measures have been taken to stow and secure those goods-

- (a) during take-off and landing; and
- (b) at all times when deemed necessary by the pilot in command of the aircraft. (L.N. 195 of 2007)

(3D) Dangerous goods specified in paragraph (3)(c), (d), (e) and (f) may be carried on an aircraft

during a flight made by the same aircraft before or after the flight in which they are carried for the purposes identified in paragraph (3)(c), (d), (e) and (f) ("the second mentioned flight") if-

- (a) it is impracticable to load or unload the dangerous goods immediately before or after (as the case may be) the second mentioned flight; and
- (b) all the following conditions are met-
 - (i) the dangerous goods are capable of withstanding the normal conditions of air transport;
 - (ii) the dangerous goods have been appropriately identified;
 - (iii) the dangerous goods are carried with the approval of the operator of the aircraft;
 - (iv) the dangerous goods have been inspected for damage or leakage prior to loading;
 - (v) loading of the dangerous goods has been supervised by the operator of the aircraft;
 - (vi) the dangerous goods have been stowed and secured in the aircraft in a manner that will prevent any movement in flight which would change their orientation;
 - (vii) the pilot in command of the aircraft has been notified of the dangerous goods loaded on board the aircraft and the location where the dangerous goods have been placed after loading;
 - (viii) in the event of a crew change, the information required to be notified under sub-paragraph (vii) has been passed to the next flight crew members;
 - (ix) all personnel have received training that is commensurate with their responsibilities with regard to the handling of dangerous goods;
 - (x) the operator of the aircraft has provided the prescribed information within the meaning of paragraph (3F) in the operations manual and other appropriate manuals as will enable his flight crew members, other employees and, where applicable, handling agents to carry out their responsibilities with regard to the transport of dangerous goods;
 - (xi) the operator of the aircraft undertakes to report any accident or incident involving dangerous goods carried on board the aircraft to the appropriate authorities of the State of the operator and the State in which such accident or incident occurred in accordance with the reporting requirements of such authorities. (L.N. 195 of 2007)

(3E) Dangerous goods specified in paragraph (3)(g) shall only be carried if all the following conditions are met-

- (a) authorization has been given by the appropriate authorities of the States concerned, and such authorities have prescribed specific terms and conditions for the particular operator's operation;
- (b) the vehicles have been secured in an upright position;
- (c) fuel tanks of the vehicles have been so filled as to prevent spillage of fuel during loading, unloading and transit; and
- (d) adequate ventilation rates have been maintained in the aircraft compartment in which the vehicles are carried. (L.N. 195 of 2007)

(3F) For the purposes of paragraph (3D)(b)(x), "prescribed information" includes-

- (a) instructions as to the action to be taken in the event of emergencies involving dangerous goods;
- (b) details of the location and numbering system of cargo compartments;
- (c) information on the maximum quantity of dry ice permitted in each cargo compartment; and
- (d) if radioactive material is to be carried, instructions as to the loading of such dangerous goods in accordance with the provisions of Chapter 2.9 of Part 7 of the Technical Instructions. (L.N. 195 of 2007)

(4) Save for Regulations 3(1)(a), 7(1) but only to the extent that it refers to the provisions in Chapter 2.1 of Part 7 of the Technical Instructions and 7(2) and 8(3) of these Regulations, these Regulations shall not apply to dangerous goods of the classifications specified in Chapter 2.4 of Part 1 of the Technical Instructions provided that: (L.N. 234 of 2001)

- (a) the dangerous goods do not exceed the appropriate quantity limitations specified

therein; and

- (b) such other conditions as are specified therein are complied with.

4. Documentation

(1) An aircraft shall not carry dangerous goods as cargo unless the shipper of the goods has furnished the operator of the aircraft with a dangerous goods transport document, except that such a document shall not be required in respect of such categories of dangerous goods as may be specified in the Technical Instructions as being goods in respect of which a dangerous goods transport document is not required.

(2)-(3) (Repealed L.N. 234 of 2001)

(4) The operator of an aircraft shall preserve for not less than six months any dangerous goods transport document or other document in respect of dangerous goods which has been furnished to him in accordance with this Regulation.

5. (Repealed L.N. 234 of 2001)

6. Operator's responsibilities

(1) The operator of an aircraft in which any package or unit load device containing dangerous goods is to be carried shall satisfy himself by making an inspection:

- (a) that the package is marked and labelled in accordance with the provisions of these Regulations, such provisions of Part 4 and Chapters 2 and 4 of Part 3 as relate to marking and labelling, and Chapters 1.5, 1.6, 1.7, 2 and 3 of Part 5 of the Technical Instructions before accepting the package; (L.N. 150 of 1997; L.N. 234 of 2001; L.N. 74 of 2006)
 - (b) that the package is not leaking or damaged so that the contents may escape-
 - (i) before accepting the package;
 - (ii) before loading or causing the package to be loaded on board the aircraft or before suspending or causing the package to be suspended beneath the aircraft, as the case may be;
 - (iii) upon loading the package from or from beneath the aircraft;
 - (c) that the unit load device is free from any evidence of leakage from or damage to any dangerous goods contained therein before loading or causing the unit load device to be loaded on board the aircraft or before suspending or causing the unit load device to be suspended beneath the aircraft, as the case may be.
- (2) (a) For the purpose of each of the inspections required by paragraph (1)(a) and (1)(b)(i) of this Regulation, an acceptance check list shall be used and the results of that inspection shall be recorded in accordance with the form thereof.
- (b) The acceptance check list shall be in such form and shall provide for the entry of such details as will enable the relevant inspection to be fully and accurately made by reference to and completion of that list.
- (c) The operator of an aircraft shall preserve for not less than six months a record of any acceptance check list completed in accordance with this Regulation. The record shall be in a legible or a non-legible form so long as the recording is capable of being reproduced in legible form.

(3) The operator shall not load or cause to be loaded on an aircraft or suspend or cause to be suspended beneath an aircraft any package or unit load device containing dangerous goods which on inspection is found to be leaking or damaged so that the contents or the dangerous goods therein may escape or be damaged.

(4) The operator shall unload or cause to be unloaded any package containing dangerous goods which appears to be leaking or damaged on board or beneath an aircraft and shall ensure other cargo or baggage loaded or suspended beneath that aircraft is in a fit state for carriage by air and has not been contaminated.

(5) The operator shall after unloading inspect for signs of damage or contamination in any part of the aircraft, or any sling or other apparatus which has been used to suspend goods beneath the aircraft, in which:

- (a) a unit load device containing dangerous goods was stowed, or
- (b) any damaged or leaking package containing dangerous goods was loaded,

and the operator shall remove or repair any contamination or damage.

(6) The operator of an aircraft shall not permit it to fly for the purpose of carrying passengers or cargo if he knows or suspects radioactive materials to have leaked in or contaminated the aircraft or any sling or other apparatus attached to the aircraft unless the radiation level resulting from the fixed contamination at any accessible surface and the non-fixed contamination are not more than the values specified in Chapter 3.2 of Part 7 of the Technical Instructions. (L.N. 234 of 2001)

7. Method of loading by operator

(1) The operator shall ensure that any package containing dangerous goods is loaded, stowed and unloaded from or from beneath an aircraft in accordance with the provisions in Chapter 2 of Part 7 of the Technical Instructions which apply to that category of dangerous goods.

(2) An aircraft shall not carry any dangerous goods either in any compartment occupied by passengers or in the flight crew compartment, except in circumstances permitted by the provisions of Chapter 2.1 of Part 7 of the Technical Instructions.

(L.N. 234 of 2001)

8. Provisions of information and training programmes by operators

(1) The operator of an aircraft in which dangerous goods are to be carried shall-

- (a) as early as practicable before departure of the aircraft, provide the commander of the aircraft with accurate and legible written or printed information in respect of the dangerous goods in accordance with the provisions of Chapters 4.1.1, 4.1.2, 4.1.4, 4.1.7 and 4.1.8 of Part 7 of the Technical Instructions;
- (b) ensure that the information is readily available to the commander during the flight; and
- (c) preserve a copy of the information for not less than six months. (L.N. 214 of 2003)

(1A) The commander shall indicate on a copy of the information provided to him under paragraph (1)(a), or in some other way, that he has received the information. (L.N. 214 of 2003)

(1B) The operator shall ensure that-

- (a) a legible copy of the information which has an indication on it, or with it, that the commander has received the information is retained on the ground; and
- (b) the copy, or the information contained in it, is readily accessible to the aerodromes of last departure and next scheduled arrival point until after the flight to which the information refers. (L.N. 214 of 2003)

(2) The operator of an aerodrome and the operator of an aircraft in which passengers are to be carried or his handling agent shall ensure that passengers of the aircraft are provided with information, in accordance with paragraph (2A), as to which categories of dangerous goods may not be taken on board the aircraft (whether as checked baggage or baggage accompanying passengers). (L.N. 74 of 2006; L.N. 195 of 2007)

(2A) The information shall be provided in notices, sufficient in number and prominence for the purposes of paragraph (2), displayed at-

- (a) each of the places at the airport where-
 - (i) tickets are issued;
 - (ii) passengers are checked in; or
 - (iii) passengers assemble to board the aircraft; and
- (b) any other location where passengers are checked in. (L.N. 195 of 2007)

(2B) The operator of an aircraft shall ensure that information required to be provided under paragraph (2) shall be-

- (a) provided with the passenger tickets issued to the passengers; or
 - (b) made available to the passengers in another manner prior to the check-in process. (L.N. 195 of 2007)
- (2C) The operator of an aircraft and his handling agent shall, during the check-in process-
- (a) seek confirmation from the passengers that they are not carrying dangerous goods that may not be taken on board the aircraft; and
 - (b) where there are suspicions that any item which is in the possession or control of any such passenger may contain dangerous goods that may not be taken on board the aircraft, seek confirmation about the contents of the item from the passenger. (L.N. 195 of 2007)
- (2D) The operator of an aircraft and his handling agent shall ensure that-
- (a) cargo acceptance staff and passenger check-in staff, as may be appropriate, are provided with information as to-
 - (i) which types of items in cargo or in passengers' baggage may contain dangerous goods as listed in Chapter 6.1 of Part 7 of the Technical Instructions;
 - (ii) the indications that suggest that there may be dangerous goods in cargo or in passengers' baggage; and
 - (iii) which categories of dangerous goods may be carried by passengers as listed in Chapter 1.1.2 of Part 8 of the Technical Instructions; and
 - (b) the information specified in subparagraph (a) is readily available to such staff. (L.N. 195 of 2007)
- (3) The operator of an aircraft, his handling agent and security agent shall-
- (a) inform any of their respective employees whose duties include a function connected with the carriage of passengers, cargo, stores or baggage by air of the provisions of the Technical Instructions;
 - (b) establish and undertake training programmes required by Chapter 4 of Part 1 of the Technical Instructions which shall be-
 - (i) submitted to the Chief Executive for approval and review on such occasions as the Chief Executive may require;
 - (ii) amended as the Chief Executive may require; and
 - (iii) delivered by instructors who satisfy the requirements set out in Chapter 4.3 of Part 1 of the Technical Instructions; and
 - (c) ensure that each of their respective employees whose duties include a function specified in subparagraph (a) shall complete the training programmes specified in subparagraph (b). (L.N. 195 of 2007)

9. Production of documents and records

The operator of an aircraft shall, within a reasonable time after being requested so to do by an authorized person, cause to be produced to that person such of the following documents as may have been requested by that person-

- (a) the written permission referred to in Regulation 3(1) of these Regulations;
- (b) the dangerous goods transport document or other document in respect of any dangerous goods referred to in Regulation 4 of these Regulations;
- (c) the completed acceptance check list in a legible form in respect of any dangerous goods, referred to in Regulation 6(2) of these Regulations;
- (d) a copy of the written or printed information provided to the commander of the aircraft in respect of any dangerous goods, referred to in Regulation 8(1) of these Regulations. (L.N. 214 of 2003)

10. (Repealed L.N. 195 of 2007)