

L.N. 124 of 2008**BUILDING (PLANNING) (AMENDMENT)
REGULATION 2008****CONTENTS**

Section	Page
1. Commencement	B2157
2. Service lanes	B2157
3. Minimum requirements of window	B2157
4. Buildings to be planned for use by persons with a disability ...	B2157
5. Schedule substituted	
Third Schedule Persons with a disability	B2157

**BUILDING (PLANNING) (AMENDMENT)
REGULATION 2008**

(Made by the Secretary for Development under section 38 of the
Buildings Ordinance (Cap. 123))

1. Commencement

This Regulation shall come into operation on a day to be appointed by the Secretary for Development by notice published in the Gazette.

2. Service lanes

Regulation 28(1) of the Building (Planning) Regulations (Cap. 123 sub. leg. F) is amended, in paragraph (a) of the proviso, in the Chinese text, by repealing “不少於 3 米闊” and substituting “闊度不少於 3 米”.

3. Minimum requirements of window

(1) Regulation 31(1)(a) is amended, in the Chinese text, by repealing “不少於 4.5 米闊” and substituting “闊度不少於 4.5 米”.

(2) Regulation 31(1)(d) is amended, in the proviso, in the Chinese text, by repealing “少於 4.5 米闊” and substituting “闊度少於 4.5 米”.

(3) Regulation 31(2)(e) is amended, in the Chinese text, by repealing “少於 4.5 米闊” and substituting “闊度少於 4.5 米”.

(4) Regulation 31(2)(e) is amended, in the Chinese text, by repealing “少於 3 米闊” and substituting “闊度少於 3 米”.

**4. Buildings to be planned for use by persons
with a disability**

(1) Regulation 72(2) is amended by repealing “Part I” and substituting “Part 2”.

(2) Regulation 72(3) is amended by repealing “Part II” and substituting “Part 4”.

5. Schedule substituted

The Third Schedule is repealed and the following substituted—

“THIRD SCHEDULE

[reg. 72]

PERSONS WITH A DISABILITY

PART 1

PRELIMINARY

1. Interpretation

For the purposes of this Schedule, unless the context otherwise requires—

“access” (通道) means any means that enable persons with a disability to approach, enter and leave the building and to use the facilities in the building without assistance or undue difficulties;

“accessible” (暢通易達), in relation to a site, building or facility or a portion of it, means the site, building, facility or portion—

(a) can be approached, entered and used conveniently by persons with a disability; and

(b) complies with this Schedule;

“accessible lift” (暢通易達升降機) means a lift that complies with the requirements set out in Division 19 of Part 2;

“assistive listening system” (聆聽輔助系統) means a system that enables sound signs that are amplified in both volume and signal to be transmitted to persons with hearing impairment without interference from background noise or excessive reverberation;

“common areas” (公用地方), in relation to a building, means areas open to, and available for the common use and enjoyment of, all occupiers of the building;

“door” (門) includes one leaf of a pair of double doors;

“persons with ambulant disabilities” (行動困難的殘疾人士) means persons with ambulant impairment who require the aid of devices such as prostheses, orthoses, sticks or crutches for walking;

“required staircase” (規定的樓梯) means an access staircase in a firefighting and rescue stairway or a staircase which provides means of escape in case of fire;

“tactile guide path” (觸覺引路帶) means a standardized pattern applied to or built onto walking surfaces through the combined use of tactile directional tiles or blocks, positional tiles or blocks and tactile hazard warning tiles or blocks, as set out in Figure No. 1 and Figure No. 2 in Part 3 of this Schedule, for way finding and orientation for persons with visual impairment;

“tactile warning strip” (觸覺警示帶) means a standardized pattern applied to or built onto walking surfaces through the use of tactile hazard warning tiles or blocks, as set out in Figure No. 2 in Part 3 of this Schedule, to warn persons with visual impairment of certain construction features;

“wheelchair users” (坐輪椅人士) means persons who depend on wheelchairs for mobility.

PART 2

DESIGN REQUIREMENTS

Division 1—Auditorium and Related Facilities

2. Application: Division 1, Part 2

This Division applies to premises with auditorium, including—

- (a) theatres;
- (b) cinemas;
- (c) concert halls;
- (d) sports stadiums;
- (e) games halls;
- (f) lecture halls; and
- (g) conference halls.

3. Interpretation: Division 1, Part 2

In this Division, “relevant activity” (有關活動) means the activity for the purpose of which the audience in the premises attend the premises.

4. Wheelchair spaces

(1) Subject to subsection (2), 2 wheelchair spaces shall be provided in premises to which this Division applies for every 400 fixed seats or any part thereof.

(2) Not less than 4 wheelchair spaces shall be provided at spectator level in an auditorium.

(3) A wheelchair space shall be adjacent to at least one other wheelchair space.

(4) Wheelchair spaces shall be adjacent to fixed seats.

(5) A wheelchair space shall have unobstructed view of the spot at which the relevant activity takes place.

(6) The side of a wheelchair space facing the spot at which the relevant activity takes place shall be not less than 800 mm and the other side shall be not less than 1 300 mm.

(7) A passage leading to a wheelchair space from an accessible entrance of an auditorium shall be not less than 1 500 mm in width.

(8) Nothing in this section prohibits the installation of readily removable seats in the wheelchair spaces when the spaces are not occupied by wheelchair users.

5. Access for wheelchair users

On premises to which this Division applies—

- (a) the auditorium, the stage, backstage facilities, changing rooms, rehearsal rooms, dressing rooms, rest rooms, toilets and shower rooms shall be accessible to wheelchair users; and
- (b) an access connecting any 2 or more of them shall be an accessible route for wheelchair users.

6. Braille and tactile fire exit maps and tactile warning strips

(1) Braille and tactile fire exit maps shall be provided at all entrances to an auditorium.

(2) Tactile warning strips shall be provided at the top and bottom ends of the staircases leading to the stage.

Division 2—Hotels, Hostels and Guesthouses

7. Guest rooms

(1) For the purposes of this section, “an accessible guest room” (暢通易達客房) means a room—

- (a) that is at an accessible location; and
- (b) in which all sleeping, bathing and sanitary facilities are accessible.

(2) Two accessible guest rooms shall be provided for every 100 guest rooms or part thereof in every hotel, hostel or guesthouse.

Division 3—Carparks

8. Ratio of accessible parking spaces

- (1) Accessible parking spaces shall be provided in every carpark.
 (2) The number of accessible parking spaces provided under subsection (1) shall conform to the table below.

TABLE

Total number of parking spaces	Minimum number of accessible parking spaces
1 – 50	1
51 – 150	2
151 – 250	3
251 – 350	4
351 – 450	5
Above 450	6

9. Requirements for accessible parking spaces

(1) An accessible route between the accessible parking spaces and the lobby with an accessible lift or entrance shall be provided.

(2) Subject to subsection (3), an accessible parking space shall be not less than 3 500 mm in width.

(3) Where a loading or unloading area which complies with subsection (4) is provided between 2 accessible parking spaces, such parking spaces shall be not less than 2 500 mm in width.

(4) For the purposes of subsection (3), a loading or unloading area shall—

- (a) be not less than 1 200 mm in width; and
- (b) be marked with yellow hatched markings.

10. Marking requirements for accessible parking spaces

The floor of an accessible parking space shall be legibly marked with—

- (a) a number assigned to the parking space; and
- (b) the international symbol of accessibility as set out in Figure No. 3 in Part 3 of this Schedule, the size of which shall be not less than 1 500 mm × 1 500 mm.

Division 4—Access Route

11. Provision of access route

(1) Subject to subsection (2), an access route shall be provided from a prominent point on the lot boundary, which is accessible to a public street or pedestrian way, directly—

(a) to—

- (i) an entrance which is commonly used by the public; or
- (ii) a point adjacent to an entrance which is commonly used by the public; and

(b) to an accessible lift.

(2) Subsection (1) does not apply if providing an accessible entrance which is commonly used by the public at a prominent point on the lot boundary is impracticable because of difficult terrain or unusual characteristics of the site.

(3) Where—

- (a) subsection (1) does not apply by virtue of subsection (2); or
- (b) the main entrance is not an accessible entrance,

a vehicular access route to the building shall be provided and adequate directional signs shall be posted at a conspicuous location of the main entrance to show clearly the location of, and the route to, an accessible entrance.

12. Requirements for access route

(1) The clear width of an access route shall be not less than 1 050 mm.

(2) An access route shall be free from—

- (a) any object or feature which impedes the passage of a wheelchair; and
- (b) any other form of barrier which will prevent access by persons with a disability,

except those objects, features or forms of barrier that comply with this Schedule.

(3) The surface of an access route shall be firm.

13. Tactile guide path

(1) This section applies to access routes provided for buildings specified in items 1, 4, 5, 7, 10, 11 and 13 in the table in Division 21.

(2) An access route shall be provided with a tactile guide path arranged in conformity to Figure No. 4 in Part 3 of this Schedule.

Division 5—Ramps

14. Ramps to be provided

Ramps shall be provided at all changes in level other than those served by an accessible lift or accessible lifting mechanism accommodating the specific requirements of persons with a disability.

15. Width of ramps

Ramps shall be not less than 1 050 mm in width.

16. Landing

(1) A clear level space of not less than 1 500 mm in width and in depth shall be provided at the head and foot of every ramp.

(2) Door swings and similar objects shall not be allowed to swing into such landing space.

17. Running slope and length

No ramp shall be steeper than 1 in 12 gradient except a single minor rise that conforms to the measurements set out in the table below.

TABLE

Maximum slope	Maximum Length	Maximum rise
1:10 i.e., 10%	1 500 mm	150 mm
1:8 i.e., 12.5%	600 mm	75 mm

18. Requirements for ramps

(1) Subject to subsection (2), where the gradient of a ramp is 1 in 20 or steeper, the ramp shall be provided—

- (a) with a landing of not less than 1 200 mm in length for each 10 m length of horizontal run or part thereof;
- (b) on both sides with handrails that comply with Division 8; and
- (c) with tactile warning strips arranged in conformity to Figure No. 5 in Part 3 of this Schedule at the head, foot and landings.

(2) Subsection (1) does not apply to—

- (a) a ramp access to lift; or
- (b) a ramp less than 300 mm in length.

19. Protection and surface

- (1) Any ramp—
 - (a) with a rise greater than 200 mm; and
 - (b) leading down towards an area where there may be vehicular traffic,

shall have a railing or barrier at a distance of not less than 1 500 mm from the foot of the ramp across the full width of the lower end of the ramp.

- (2) On the surface of a ramp, raised traction strips shall be avoided.

(3) A kerb of not less than 100 mm in height, or a rail 200 mm above ramp level, shall be provided on both sides to prevent a wheelchair from slipping over the edge.

(4) There shall be no appliances, fixtures or fittings projecting beyond 90 mm from the surface of any wall adjacent to a ramp below a level of 2 000 mm above the ramp level unless such appliances, fixtures or fittings are unavoidable on reasonable ground.

(5) Appliances, fixtures and fittings that are unavoidable on reasonable ground shall be—

- (a) extended downwards to the ramp level; or
 - (b) guided by tactile flooring materials.
- (6) The floor and wall along ramps shall be in contrasting colours.

Division 6—Dropped Kerbs

20. General provision: dropped kerbs

(1) A dropped kerb in the form of a ramp shall be provided at a pedestrian crossing and at each end of a footpath of a private street or access road to accommodate the change in level towards a vehicular area.

(2) A kerb separating a footpath or ramp from a vehicular area shall also be in the form of a dropped kerb.

21. Requirements for dropped kerbs

Dropped kerbs shall be—

- (a) not less than 1 200 mm in length and 1 200 mm in width;
- (b) provided with a clearance not less than 800 mm in length at the back of the footway;
- (c) ramped at a gradient not steeper than 1 in 10;

- (d) at a level difference of not more than 15 mm with the vehicular areas;
- (e) provided with a tactile warning strip at 300 mm from the vehicular areas; and
- (f) provided with a tactile warning strip of a nominal width of 600 mm at the ramp.

22. Location of dropped kerbs

A dropped kerb shall be so located as to enable users to have an unobstructed view of traffic approaching from any direction.

23. Surface of dropped kerbs

On the surface of a dropped kerb, raised traction strips shall be avoided.

Division 7—Steps and Staircases

24. Application: Division 7, Part 2

This Division applies only to the required staircases and the main circulation staircase in the common areas of a building.

25. Dimension and orientation of staircase

- (1) A tread of a step in a staircase shall be—
 - (a) (in the case of internal staircases) not less than 225 mm in width measured from the face of one riser to the face of the next riser; or
 - (b) (in the case of external staircases) not less than 280 mm in width measured from the face of one riser to the face of the next riser.
- (2) A tread shall be provided with a non-slip nosing which is not a projecting nosing.
- (3) A nosing and the tread shall be in contrasting colours.
- (4) A tread and the adjacent wall shall be in contrasting colours.
- (5) A riser of a step in a staircase shall be—
 - (a) (in the case of internal staircases) not more than 175 mm in height; or
 - (b) (in the case of external staircases) not more than 160 mm in height.

- (6) A riser shall be built with—
- (a) a vertical face; or
 - (b) a receding face not more than 15 mm from the point perpendicular to the edge of the nosing of the next higher tread.
- (7) A staircase shall be provided on both sides with properly fitted handrails.
- (8) A flight of staircase shall have not more than 16 steps.
- (9) For the purposes of subsection (8), steps between 2 landings shall be regarded as constituting a flight of staircase.

26. Tactile warning strip for staircase

- (1) Tactile warning strips arranged in conformity to Figure No. 6 in Part 3 of this Schedule shall be provided at—
- (a) landings of a staircase; and
 - (b) both the top and bottom ends of a staircase.
- (2) Tactile warning strips provided at landings leading to a floor or landings enclosed by wall, railing or balustrade shall be 300 mm in width.
- (3) Tactile warning strips provided at landings leading to an open space or the entrance or exit of a building shall be 600 mm in width.
- (4) Where tactile warning strips are provided at landings referred to in subsection (3), Braille and tactile information signs shall be provided on the adjacent wall to indicate the presence of an opening.
- (5) Tactile warning strips provided for a staircase with intermediate steps between the two flights shall be arranged in conformity to Figure No. 6 in Part 3 of this Schedule.

27. Avoidance of projection

- (1) There shall be no appliances, fixtures or fittings projecting beyond 90 mm from the surface of any wall adjacent to a staircase below a level of 2 000 mm above the treads of the staircase unless such appliances, fixtures or fittings are unavoidable on reasonable ground.
- (2) Appliances, fixtures and fittings that are unavoidable on reasonable ground shall be extended downwards to the level of the treads.

Division 8—Handrails

28. Dimension and shape of handrail

(1) A handrail to ramps and steps shall be fixed not less than 30 mm and not more than 50 mm clear of wall and with a clear height of 70 mm from the top of the bracket to the top of the handrail.

(2) The top of a handrail shall be at a height of not less than 850 mm and not more than 950 mm above any nosing, floor or landing.

(3) A handrail shall be—

(a) tubular; or

(b) in any other shapes that can provide the user a grip similar to that provided by a tubular handrail.

(4) The external diameter of a handrail shall be not less than 32 mm and not more than 50 mm.

(5) A handrail shall—

(a) extend horizontally not less than 300 mm beyond the first and last nosing of every flight of staircase or beyond the ends of a ramp; and

(b) terminate into a closed end, which shall turn down or return fully to end post or wall face and which shall not project into a route of travel.

(6) Notwithstanding subsection (5)(a), where a door opening is in place, the horizontal extension may be shortened to not less than 100 mm.

29. Loading

(1) A handrail shall be so installed as to resist a load of not less than 1.3 kN applied vertically or horizontally.

(2) A handrail shall not be fitted in a manner that allows it to rotate within its fixing fittings.

30. Braille and tactile information

(1) Braille and tactile information on directional arrows and floor numbers shall be provided on handrails on every floor to facilitate persons with visual impairment.

(2) Where directional signs exist on handrails, Braille and tactile information shall also be provided in conformity to Figure No. 6 in Part 3 of this Schedule.

Division 9—Corridors, Lobbies and Paths

31. Manoeuvring space

(1) A corridor, lobby, path or similar space shall have a clear width of not less than 1 050 mm.

(2) A space of not less than 1 500 mm in width and in depth shall be provided within 3 500 mm of a corridor, lobby or path where the means of exit for persons with a disability is in one direction only.

(3) A lobby in a corridor shall be not less than 1 200 mm in length (excluding space for door swings).

(4) A level area extending not less than 1 200 mm beyond the swings of the doors and not less than 1 500 mm in width shall be provided on both sides of every entrance of a building.

(5) This section does not apply to lobbies which lead to staircases only.

32. Channel covers

(1) Covers to channels on footpaths shall be flush with the surface of the footpaths.

(2) The dimension of any hole in such cover or between such covers shall be not more than 20 mm.

33. Gratings

Slots of gratings shall—

- (a) have a width of not more than 13 mm; and
- (b) not be parallel to the pedestrian travel path.

34. Protrusion

(1) There shall be no appliances, fixtures or fittings projecting beyond 90 mm from the surface of any wall adjacent to corridors, lobbies or paths below a level of 2 000 mm above the finished floor level unless such appliances, fixtures or fittings are unavoidable on reasonable ground.

(2) Appliances, fixtures and fittings that are unavoidable on reasonable ground shall be—

- (a) extended downwards to the finished floor level; or
- (b) guided by tactile flooring materials.

35. Controlled passage

- (1) In this section, “controlled passage” (受管制通道) means—
 - (a) a cashier counter at a shop;
 - (b) a passage through anti-theft device installed at a shop; or
 - (c) a turnstile-controlled passage accessible to the public.
- (2) Subject to subsection (4), a path shall be provided at each controlled passage for the use by wheelchair users.
- (3) A path so provided shall be—
 - (a) not less than 800 mm in width; and
 - (b) clearly marked with the international symbol of accessibility as set out in Figure No. 3 in Part 3 of this Schedule.
- (4) Subsection (2) does not apply if an alternative passage for wheelchair users adjacent to the controlled passage is provided.

36. Headroom

- (1) Where a headroom does not exceed 2 000 mm from the finished floor level, a warning guardrail or other barrier shall be provided for detection.
- (2) The leading edge of a warning guardrail or barrier shall be at or below 680 mm above the finished floor level.

Division 10—Doors**37. Application: Division 10, Part 2**

This Division applies to doors on accessible routes.

38. Width of doors

- A door shall have a clear width of not less than 800 mm between the open door and—
- (a) the opposite jamb; or
 - (b) where the door is one leaf of a pair of double doors, the other leaf.

39. Unobstructed area

- (1) An unobstructed area which is—
 - (a) not less than 330 mm in width; and
 - (b) adjacent to the door handle on the leading face of a single door,shall be provided.

(2) A door which is less than 330 mm from the corner of a room shall be so constructed and installed that it swings from the side nearer to that corner.

40. **Double-action self-closing doors**

A double-action self-closing door shall have—

- (a) a check mechanism that is designed to prevent the door swinging beyond the closed position; and
- (b) a transparent vision-panel with a bottom edge not more than 1 000 mm above the finished floor level and a top edge not less than 1 500 mm above the finished floor level.

41. **Handles**

A door handle shall be not less than 950 mm and not more than 1 050 mm above the finished floor level, measured from the top surface of the grip.

42. **Door thresholds**

A door threshold shall be—

- (a) not more than 20 mm in height; and
- (b) bevelled to facilitate passage of wheelchairs.

43. **Door closing devices**

(1) For the purposes of this section, “a door closing device” (關門機掣) includes a door closer, spring hinge and floor hinge.

(2) A door closing device shall be so designed as to allow the door to be opened with—

- (a) (in the case of an interior door) a horizontal force of not more than 22 N; or
- (b) (in the case of an exterior door) a horizontal force of not more than 30 N.

(3) A door required to have fire resistance period installed along an accessible route shall be so designed as to allow it to be opened with a horizontal force of not more than 30 N.

(4) A door closer for an interior door shall have a closing period of at least 3 seconds measured from an open position of 70° to a point 75 mm from the closed position measured from the leading edge of the door.

44. Frameless glass doors

(1) A frameless glass door and the glass panel adjacent to it (if any) shall be prominently marked so as to make them conspicuous.

(2) At least a portion of the marking shall be placed not less than 900 mm and not more than 1 500 mm above the finished floor level.

45. Automatic main entrance doors

(1) This section applies to—

- (a) sports stadiums;
- (b) town halls;
- (c) civic centres;
- (d) theatres;
- (e) museums;
- (f) public libraries;
- (g) shopping complexes;
- (h) sports complexes;
- (i) public swimming pool complexes;
- (j) office buildings;
- (k) hotels; and
- (l) hospitals.

(2) An automatic door shall be installed at—

- (a) the only main entrance of a building; or
- (b) at least one of the main entrances of a building which is commonly used by the public,

as may be appropriate.

Division 11—Toilets and Water Closet Cubicles**46. Provision of accessible water closet cubicle**

(1) This section does not apply to—

- (a) domestic buildings and domestic parts of composite buildings; or
- (b) a floor in a building on which no toilet is provided.

(2) Subject to subsection (3), where the total number of water closet cubicles provided on a floor—

- (a) is 20 or less, at least one accessible water closet cubicle shall be provided on that floor; or
- (b) exceeds 20, at least 2 accessible water closet cubicles shall be provided on that floor.

(3) If an accessible water closet cubicle provided on a floor is provided in a toilet with multiple cubicles, subsection (2) has effect as if a reference to a floor in that subsection was a reference to a toilet with multiple cubicles.

(4) For the purposes of subsection (2), “floor” (樓層) includes a part of a floor designed for access by persons with a disability.

47. Accessible unisex toilet

(1) Where toilet is provided on a floor, at least one toilet shall be designed as an accessible unisex sanitary facility for use by persons of both sexes.

(2) An accessible unisex toilet provided under subsection (1) shall be so located that access to it does not necessitate traversing an area reserved for one sex only.

48. Location of accessible water closet cubicle

(1) An accessible water closet cubicle provided in a toilet with multiple cubicles shall be accessible—

- (a) through a clear space of not less than 1 500 mm in width and in depth immediately in front of the cubicle; or
- (b) by direct approach where no turning of the wheelchair is necessary.

(2) An accessible water closet cubicle that is not provided in a toilet with multiple cubicles shall be accessible directly from a public corridor.

49. Design of accessible water closet cubicle

(1) The internal area of an accessible water closet cubicle shall be not less than 1 500 mm × 1 750 mm.

(2) The clear manoeuvring space within an accessible water closet cubicle shall be not less than 1 500 mm × 1 500 mm in area measured at 350 mm above the finished floor level.

(3) An accessible water closet cubicle shall have in it a water closet—

- (a) at a height of not less than 380 mm and not more than 450 mm, measured to the top of the toilet seat;
- (b) equipped with a back support such as a seat lid; and
- (c) the seat of which shall not be spring-actuated.

50. Flushing controls

(1) This section applies to flushing controls in accessible water closet cubicles.

(2) A flushing control shall be—

(a) mounted on the wide side of the cubicle at a height of not less than 600 mm and not more than 1 050 mm above the finished floor level; and

(b) hand-operated or automatic.

(3) A hand-operated flushing control shall—

(a) be capable of being operated with one hand;

(b) not require tight grasping, pinching or twisting of the wrist; and

(c) be able to be operated with a force not greater than 22 N.

51. Wash basins in toilets with accessible water closet cubicle

(1) This section applies to wash basins in toilets with accessible water closet cubicle.

(2) A toilet with accessible water closet cubicle shall be provided with a wash basin mounted with the rim at a height of not more than 750 mm above the finished floor level.

(3) There shall be a clearance of 550 mm from the finished floor level to the bottom of the apron of a wash basin.

(4) Subject to the approval of the Director of Water Supplies, the tap for a wash basin shall be automatic or of lever control type without spring loading.

(5) The tap for a wash basin shall—

(a) not require tight grasping, pinching or twisting of the wrist; and

(b) be able to be operated with a force not greater than 22 N.

(6) A wash basin shall be capable of carrying a static load of 150 kg.

52. Door of toilets or cubicles

(1) The door of an accessible water closet cubicle or a toilet with such cubicle shall be—

(a) installed with push-type or lever-type handle on both sides of the door; and

(b) capable of being easily opened or closed by one hand.

(2) The door fastening of a door referred to in subsection (1) shall be capable of being released from the outside in the event of an emergency.

(3) No coin box shall be affixed to the door of an accessible water closet cubicle.

53. Grab rails in cubicles

(1) Inside an accessible water closet cubicle, there shall be—

(a) subject to subsection (2), at least one horizontal grab rail of not less than 600 mm in length and at least one vertical grab rail of not less than 600 mm in length arranged in L-shaped configuration fixed on the wall facing one side of the water closet; and

(b) one folding grab rail fixed on the wall at the back of the water closet which can be lowered to provide support on the other side of the water closet.

(2) The requirement of subsection (1)(a) is to be regarded as being satisfied if an L-shaped grab rail which is not less than 1 200 mm in length is fixed on the wall facing the side of the water closet.

(3) A folding grab rail shall be so fixed that it is at a height of not less than 725 mm and not more than 750 mm above the finished floor level when lowered from the wall.

(4) A notice containing simple instructions in English, Chinese and Braille on how to unfold a folding grab rail shall be affixed to the wall on which the rail is fixed.

(5) There shall be—

(a) a horizontal grab rail fixed on the inner surface of the door of an accessible water closet cubicle; and

(b) a horizontal grab rail fixed on the outer surface of such door.

(6) A grab rail fixed in compliance with this section shall—

(a) be not less than 32 mm and not more than 40 mm in external diameter;

(b) be so fixed that a grip space of not less than 30 mm clear of the wall or door surface is left; and

(c) not be fitted in a manner that allows it to rotate within its fixing fittings.

(7) A grab rail referred to in subsection (1) shall be—

(a) not less than 600 mm in length; and

(b) capable of carrying a static load of 150 kg.

54. Emergency call bell

An emergency call bell that complies with Division 17 shall be provided in an accessible water closet cubicle.

55. Urinals

- (1) If more than one urinal is provided, at least one urinal shall—
 - (a) have a clear levelled space of not less than 800 mm in width and not less than 1 500 mm in depth in front of the urinal; and
 - (b) be wall hung urinal with a front rim at a height of not more than 400 mm above the finished floor level.
- (2) Vertical grab rails shall be fixed on both sides of a urinal referred to in subsection (1) on the wall on which the urinal is mounted for use by persons with ambulant disabilities.
- (3) A grab rail shall—
 - (a) have an external diameter of not less than 32 mm and not more than 40 mm;
 - (b) be not less than 600 mm in length; and
 - (c) be at a height of 1 200 mm above the finished floor level.

Division 12—Bathrooms and Shower Compartments**56. Bathtubs in accessible bathrooms**

- (1) There shall be a clear floor space of not less than 1 500 mm in width and 800 mm in depth in front of the bathtub in an accessible bathroom.
- (2) A bathtub shall be provided with a seat of not less than 250 mm in width.
- (3) A bathtub shall have a height of not more than 380 mm.

57. Grab rails for bathtub

- (1) A grab rail shall be fixed on the wall along the length of a bathtub in an accessible bathroom.
- (2) A grab rail shall be—
 - (a) not less than 900 mm in length;
 - (b) fixed horizontally or slanting at an angle not exceeding 20°; and
 - (c) at a height of not less than 150 mm and not more than 300 mm above the rim of the bathtub.

(3) A vertical grab rail of not less than 600 mm in length shall be fixed on the wall at the plug end of the bathtub adjacent to the clear floor space referred to in section 56(1).

(4) The lower end of a vertical grab rail referred to in subsection (3) shall be not less than 150 mm and not more than 300 mm above the rim of the bathtub.

(5) A grab rail referred to in subsection (1) or (3) shall—

- (a) have an external diameter of not less than 32 mm and not more than 40 mm;
- (b) be so fixed that a grip space of not less than 30 mm clear of the wall is left; and
- (c) not be fitted in a manner that allows it to rotate within its fixing fittings.

58. Taps and controls of bathtubs

Taps and other controls of a bathtub in an accessible bathroom shall—

- (a) have lever type handle the length of which shall not be less than 75 mm measured from the centre of rotation to the handle tip;
- (b) be installed at the plug end of the bathtub; and
- (c) be not more than 450 mm above the rim of the bathtub.

59. Shower heads

(1) A shower head for a bathtub in an accessible bathroom shall be—

- (a) of the hand-held type;
- (b) provided with a hose not less than 1 500 mm in length; and
- (c) provided with a bracket mounted on the wall to allow use in a fixed position.

(2) Where a shower head is mounted on a vertical bar, the bar shall be—

- (a) not less than 500 mm in length, with the lower end not less than 450 mm above the finished floor level;
- (b) so installed that the use of grab rails referred to in section 57 is not obstructed; and
- (c) capable of carrying a static load of 150 kg.

60. Shower compartments

(1) An accessible shower compartment shall have internal dimensions of not less than 1 500 mm in width and not less than 900 mm in depth.

(2) A clear floor space of not less than 1 500 mm x 800 mm with the dimension parallel to the shower entrance being not less than 1 500 mm shall be provided in front of the entrance of the compartment.

61. Grab rails for shower compartments

(1) A horizontal grab rail not less than 900 mm in length shall be fixed on the wall on which the taps and other controls in an accessible shower compartment are mounted.

(2) A horizontal grab rail of not less than 750 mm in length shall be fixed on the wall next to the wall referred to in subsection (1).

(3) The requirements of subsections (1) and (2) can also be satisfied by fixing on the 2 walls referred to in those subsections a horizontal L-shaped grab rail provided that if the 2 sections of the rail were separate rails, they both satisfy the requirements of those subsections.

(4) A grab rail shall—

- (a) have an external diameter of not less than 32 mm and not more than 40 mm;
- (b) be at a height of not less than 700 mm and not more than 800 mm above the finished floor level;
- (c) have a grip space of not less than 30 mm clear from the wall;
- (d) not be fitted in a manner that allows it to rotate within its fixed fittings; and
- (e) be capable of carrying a static load of 150 kg.

62. Thresholds of accessible shower compartments

Thresholds of accessible shower compartments shall—

- (a) be not more than 13 mm in height; and
- (b) have bevelled edges.

63. Shower seats

A shower seat provided in an accessible shower compartment—

- (a) have a rounded edge;
- (b) be self-draining;

- (c) be installed on the wall adjacent to the wall on which the taps and other controls are mounted;
- (d) be not less than 550 mm in width and 400 mm in depth; and
- (e) shall be installed at a height of not less than 430 mm and not more than 480 mm measured from the top of the seat to the finished floor level.

Division 13—Signs

64. International symbol of accessibility

The international symbol of accessibility as set out in Figure No. 3 in Part 3 of this Schedule shall be provided at conspicuous location for the purposes of indicating—

- (a) accessible entrances to the building;
- (b) accessible exits from the building;
- (c) car parking facilities reserved for persons with a disability;
- (d) the location of toilets for persons with a disability;
- (e) usable vertical circulation facilities;
- (f) usable cloakroom facilities; and
- (g) the availability of special services of information or service counters and telephones in the building.

65. Directional signs

Directional arrows and visual information shall be provided at conspicuous locations in conjunction with the international symbol of accessibility to guide persons with a disability to the exact locations of the accessible facilities.

66. Size of signs

(1) This section applies to signs displayed in compliance with this Division.

(2) The height of signs displayed on doors shall be not less than 60 mm.

(3) The height of signs displayed in corridors shall be not less than 110 mm.

(4) The height of signs displayed at external locations shall be not less than 200 mm.

67. Signs for persons with hearing impairment

The international symbol of access for hearing loss as set out in Figure No. 7 in Part 3 of this Schedule shall be provided if there is an assistive listening system provided for persons with hearing impairment.

68. Braille and tactile signs

(1) Braille and tactile signs shall be fixed on adjacent walls or doors of a public toilet to indicate whether the toilet is for male, female or unisex.

(2) Such signs shall be placed at a height of not less than 900 mm and not more than 1 500 mm above the finished floor level.

(3) If a public toilet has no door, such signs shall be fixed on the toilet front wall.

(4) A Braille and tactile fire exit map shall be provided directly above the call button of the accessible lift in the lobby of that lift in a building if a fire exit map for the use of the public is provided.

(5) Such map shall be placed at a height of not less than 800 mm and not more than 1 200 mm above the finished floor level.

Division 14—Special Design Requirements to assist Persons with Visual or Hearing Impairment**69. Special design requirements to assist persons with visual or hearing impairment**

(1) This section applies to any part of a building used for the purposes as specified in Division 21.

(2) If a floor plan for the use of the public is provided, Braille and tactile floor plan showing the main entrance, public toilet and major common facilities shall be provided in a place in that building which is conspicuous to persons with visual impairment.

(3) Tactile guide path shall be installed—

(a) from a point of access at the lot boundary to the main entrance of the building; and

(b) from the main entrance to—

- (i) lift zone;
- (ii) the nearest accessible toilet;
- (iii) the nearest public information or service counter;
- (iv) the nearest Braille and tactile floor plan; and
- (v) the nearest staircase.

(4) If a visual display board is provided, it shall be able to display the essence of the information broadcasted by the public address system in the building, if any.

Division 15—Public Information or Service Counters

70. Provision of public information or service counters

(1) There shall be public information or service counters in buildings specified in Division 21.

(2) In every building there shall be—

- (a) at least one public information or service counter built with a portion not more than 750 mm in height above the finished floor level and not less than 750 mm in width to assist wheelchair users; and
- (b) at least one public information or service counter provided with an assistive listening system where the surrounding environment is noisy or where a screen is installed at the counter.

71. Design of counters

(1) A public information or service counter shall be accessible and easily identifiable from the building entrance by persons with a disability.

(2) Leg space of—

- (a) not less than 400 mm and not more than 600 mm in depth; and
- (b) not less than 680 mm in height above the finished floor level,

shall be provided at a public information or service counter.

Division 16— Illumination

72. General illumination level

(1) The ground floor entrance lobby and the lifts in a building shall, when they are reasonably expected to be used by the public during the period of normal use or occupation or when required, have illumination level of not less than 120 lux measured at the finished floor level at the centre point of the lobby or lift, as the case may be.

(2) The lift lobby of a floor other than the ground floor of a building shall, when it is reasonably expected to be used by the public during the period of normal use or occupation or when required, have illumination level of not less than 85 lux measured at the finished floor level at the centre point of the lobby.

(3) The corridors, accessible paths and staircases in a building shall, when they are reasonably expected to be used by the public during the period of normal use or occupation or when required, have illumination level of not less than 85 lux measured at the finished floor level along the centre line of the corridor, path or staircase, as the case may be.

73. Illumination level for signs

Signs provided in compliance with Division 13 shall have illumination level on the sign surface of not less than 120 lux.

74. Means of provision of illumination

The illumination may be provided through automatic or manual switching devices.

Division 17—Emergency Call Bells in Accessible Toilets

75. Emergency call bells in accessible toilets

(1) An emergency call bell shall be installed for every accessible water closet cubicle required under Division 11.

(2) An emergency call bell when activated shall emit audible or visible alarm signal which shall be readily noticeable for summoning assistance for the people in the accessible toilet.

(3) Subject to subsection (4), an alarm of an emergency call bell shall be installed outside the accessible toilet.

(4) Subsection (3) does not apply if a buzzer which emits audible signal when the emergency call bell is activated is fitted in the caretaker's office in the building.

76. Push button for emergency call bell

(1) An emergency call bell required under section 75(1) shall be equipped with a waterproof push button for activating the alarm.

(2) The push button shall be installed below the vertical grab rail inside the water closet cubicle adjacent to the water closet at a height of not less than 600 mm and not more than 650 mm above the finished floor level.

(3) A notice containing the words “Emergency Call”, the characters “緊急召援” and Braille to the like effect shall be fitted next to the push button.

Division 18—Assistive Listening System

77. Assistive listening system

An assistive listening system (such as an induction loop system or an infra-red system) shall be provided in—

- (a) at least one of the public information or service counters, if any, in any building belonging to the categories of buildings set out in Division 21; and
- (b) the hall and auditorium, if any, of such a building.

Division 19—Lifts

78. Special requirements for accessible lifts

(1) Subject to subsection (2), every floor of a building shall be accessible by at least one passenger lift which—

- (a) has internal car dimensions of not less than 1 100 mm in width and not less than 1 200 mm in depth;
- (b) has a clear entrance of not less than 850 mm in width; and
- (c) is fitted with handrails—
 - (i) which extends to within 150 mm of the corners at the rear and sides of the car;
 - (ii) the top of the gripping surface of which is at a height of not less than 850 mm and not more than 950 mm above the finished floor level; and
 - (iii) which is so fitted that a space of not less than 30 mm and not more than 50 mm is left between the handrails and wall.

(2) Where there are more than 3 lifts in a building, access shall be provided to every floor by at least one lift which—

- (a) has internal car dimensions of not less than 1 500 mm × 1 400 mm (in either width or depth); and
- (b) has a clear entrance of not less than 850 mm in width.

79. Lift doors

(1) Lift car doors and landing doors shall be of the horizontally sliding type, power-operated and automatically controlled.

(2) An audible signal shall be provided to signify the closing of the doors to alert persons.

(3) A detection device shall be provided to re-open the lift doors if the closing lift doors hit any obstacle.

(4) Such detection device shall be positioned at not less than 500 mm and not more than 600 mm above the floor of the lift car.

80. Lift control buttons

(1) The—

- (a) floor numbering buttons;
- (b) emergency call bell push buttons; and
- (c) door opening push buttons,

in a lift car shall be not less than 900 mm and not more than 1 200 mm above the floor of the car.

(2) The lift call buttons at a lift lobby shall be not less than 900 mm and not more than 1 200 mm above the finished floor level of the lobby.

(3) Subsections (1) and (2) do not apply to secondary control panels for over-spilled floor numbering buttons.

(4) All buttons referred to in subsections (1) and (2) shall have a dimension of not less than 20 mm.

(5) Braille and tactile markings shall be placed—

- (a) on the buttons referred to in subsections (1) and (2); or
- (b) to the left of such buttons.

(6) The Braille and tactile markings shall—

- (a) have a dimension of not less than 15 mm in height; and
- (b) be raised not less than 1 mm.

(7) The tactile markings for push buttons for the main entrance floor shall be identified with a symbol in a star shape.

(8) An emergency call bell push button shall be identified with a symbol in a bell shape.

81. Indication and notification for accessible lifts

(1) Subject to subsection (3), an illuminated visual indicator and an audible signal shall be provided at a lift entrance to indicate—

- (a) the arrival of the lift car; and
- (b) the direction of travel of the lift car.

- (2) The audible signal shall—
 - (a) be activated before the arrival of the lift car at the floor;
 - (b) sound once if the lift car is moving upward; and
 - (c) sound twice if the lift car is moving downward.
- (3) The audible signal can be generated by a device in the lift car provided that it can be heard from the lift lobby.
- (4) Tactile and Braille floor designations shall be provided on the jambs on both sides of each lift entrance by means of Arabic numerals.
- (5) Such floor designations shall be—
 - (a) not less than 60 mm in height;
 - (b) raised 1 mm; and
 - (c) at 1 200 mm above the finished floor level of the lift lobby.

82. **Indication in accessible lift cars**

- (1) Illuminated visual position indicators shall be provided in a lift car to indicate—
 - (a) the direction of travel of the lift car; and
 - (b) the position of the lift car.
- (2) The indicating numerals or signs on the illuminated visual position indicator shall be not less than 50 mm in height.
- (3) An audio indication in English, Cantonese and Putonghua of the stopping floor shall be provided.

83. **Identification of accessible lifts in lift lobbies**

- (1) If not all lifts in a building comply with this Division, each of the lifts that comply with this Division shall be identified, by at least one international symbol of accessibility (as set out in Figure No. 3 in Part 3 of this Schedule), at each landing served by the lift.
- (2) If the only lift or all the lifts, as may be appropriate, in a building comply with this Division, at least one international symbol of accessibility (as set out in Figure No. 3 in Part 3 of this Schedule) shall be provided at each lift lobby on the entrance level of the building.

Division 20—Escalators and Passenger Conveyors**84. Requirements for escalators and passenger conveyors**

Adequate warning or guarding shall be provided alongside and at each end of escalators and passenger conveyors for the safety of persons with visual impairment.

85. Tactile warning strips

(1) Tactile warning strips arranged in conformity with Figure No. 8 in Part 3 of this Schedule shall be provided at the top and bottom ends of an escalator.

(2) Tactile warning strips arranged in conformity to Figure No. 8 in Part 3 of this Schedule shall be provided at both ends of a passenger conveyor.

Division 21—Extent of Application of Additional Assistive Provisions**86. Application of additional assistive provisions**

Sections 13, 69, 70 and 77 shall only be applicable to buildings or part of the buildings used for the purposes as indicated in the table below.

TABLE

Uses of buildings	Required additional assistive provisions				
	Braille and tactile floor plan [section 69(2)]	Tactile guide path [sections 13 and 69(3)]	Visual display board [section 69(4)]	Accessible public information or service counter [section 70]	Assistive listening system [section 77]
1. Department store and shopping complex	Applicable	Applicable	Not applicable	Applicable	Not applicable
2. Hotel, hostel, guesthouse and bank	Applicable	Not applicable	Not applicable	Applicable	Not applicable
3. Place for worship	Applicable	Not applicable	Not applicable	Applicable	Not applicable
4. Cinema, theatre, concert hall, stadium, museum, theme park and purpose-built family amusement centre	Applicable	Applicable	Applicable	Applicable	Applicable
5. School, college, university and public library	Applicable	Applicable	Not applicable	Applicable	Not applicable
6. Factory, workshop and place for industrial use	Not applicable	Not applicable	Not applicable	Not applicable	Not applicable
7. Sport complex and public swimming pool complex	Applicable	Applicable	Not applicable	Applicable	Not applicable

Uses of buildings	Required additional assistive provisions				
	Braille and tactile floor plan [section 69(2)]	Tactile guide path [sections 13 and 69(3)]	Visual display board [section 69(4)]	Accessible public information or service counter [section 70]	Assistive listening system [section 77]
8. Restaurant and food court	Applicable	Not applicable	Not applicable	Not applicable	Not applicable
9. Indoor market and supermarket	Applicable	Not applicable	Not applicable	Not applicable	Not applicable
10. Hospital and purpose-built clinic	Applicable	Applicable	Applicable	Applicable	Applicable
11. Residential home for the elderly and welfare centre	Applicable	Applicable	Not applicable	Applicable	Not applicable
12. Club house	Applicable	Not applicable	Not applicable	Applicable	Not applicable
13. Transport station, interchange and passenger terminal	Applicable	Applicable	Applicable	Applicable	Applicable
14. Carpark	Applicable	Not applicable	Not applicable	Not applicable	Not applicable

PART 3

FIGURE NO. 1

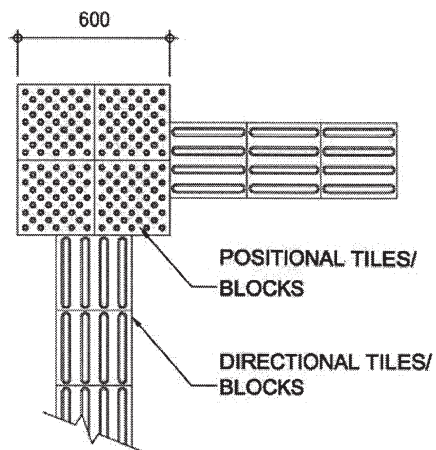
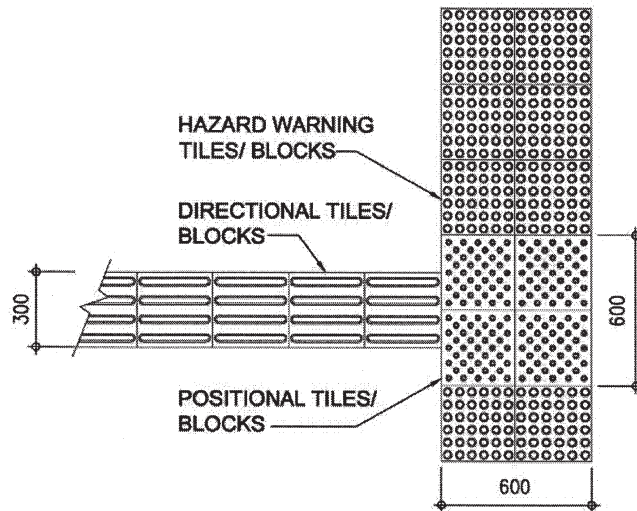

*ALL DIMENSIONS ARE IN mm

Typical tactile guide path junction.

FIGURE NO. 2

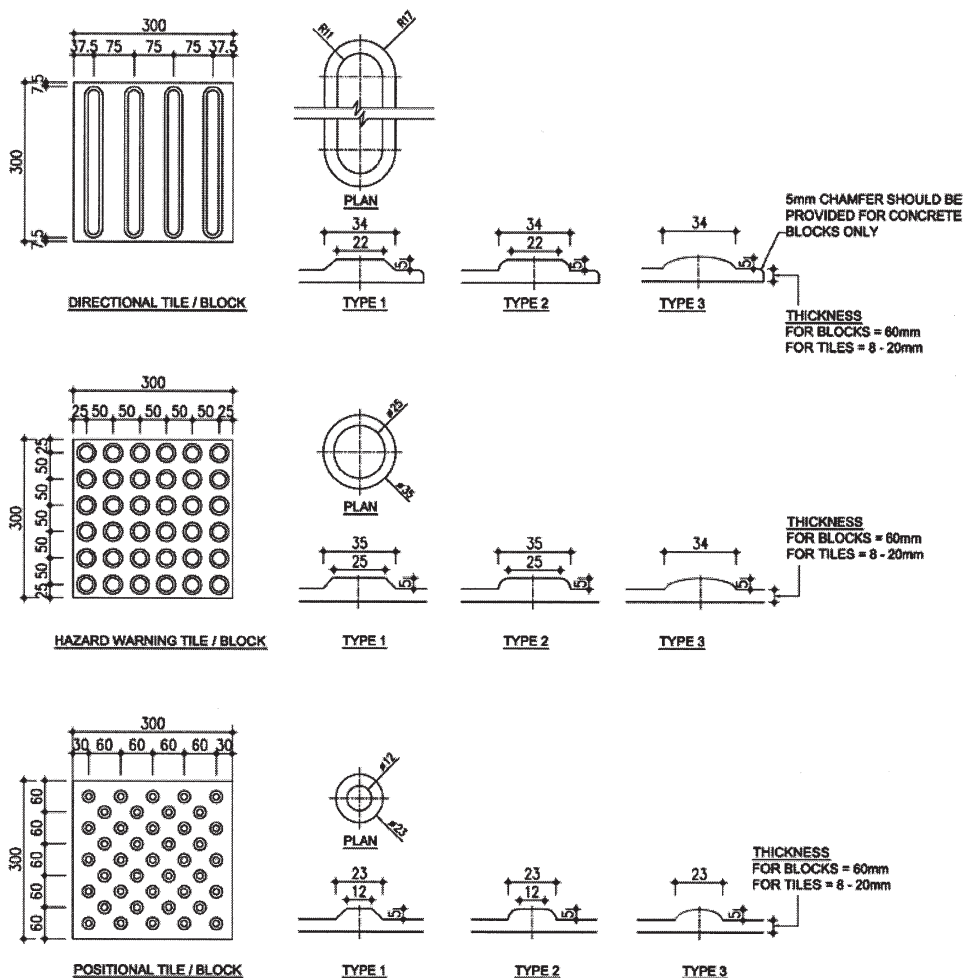

*ALL DIMENSIONS ARE IN mm

The figure shows the three kinds of tactile tiles or blocks commonly used in constructing a tactile guide path. Directional tile or block has parallel raised bars for guiding the users along an intended safe path. Hazard warning tile or block has raised big dots (35 mm in diameter) arranged in square grid parallel to the sides of the slab for indication of potential hazards ahead. This type of tile or block can be used alone to form tactile warning strips at the top and bottom ends of staircase or ramps, and at dropped kerb. Positional tile or block has raised small dots (23 mm in diameter) placed in staggered positions for indication of possible change in walking directions.

FIGURE NO. 3

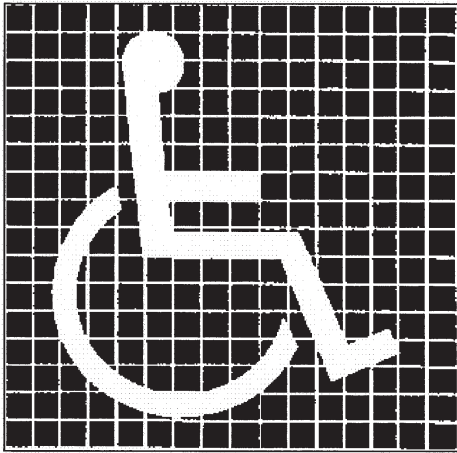

GRIDLINES ARE SHOWN TO DEFINE
THE PROPORTION ONLY

International symbol of accessibility.

FIGURE No. 4

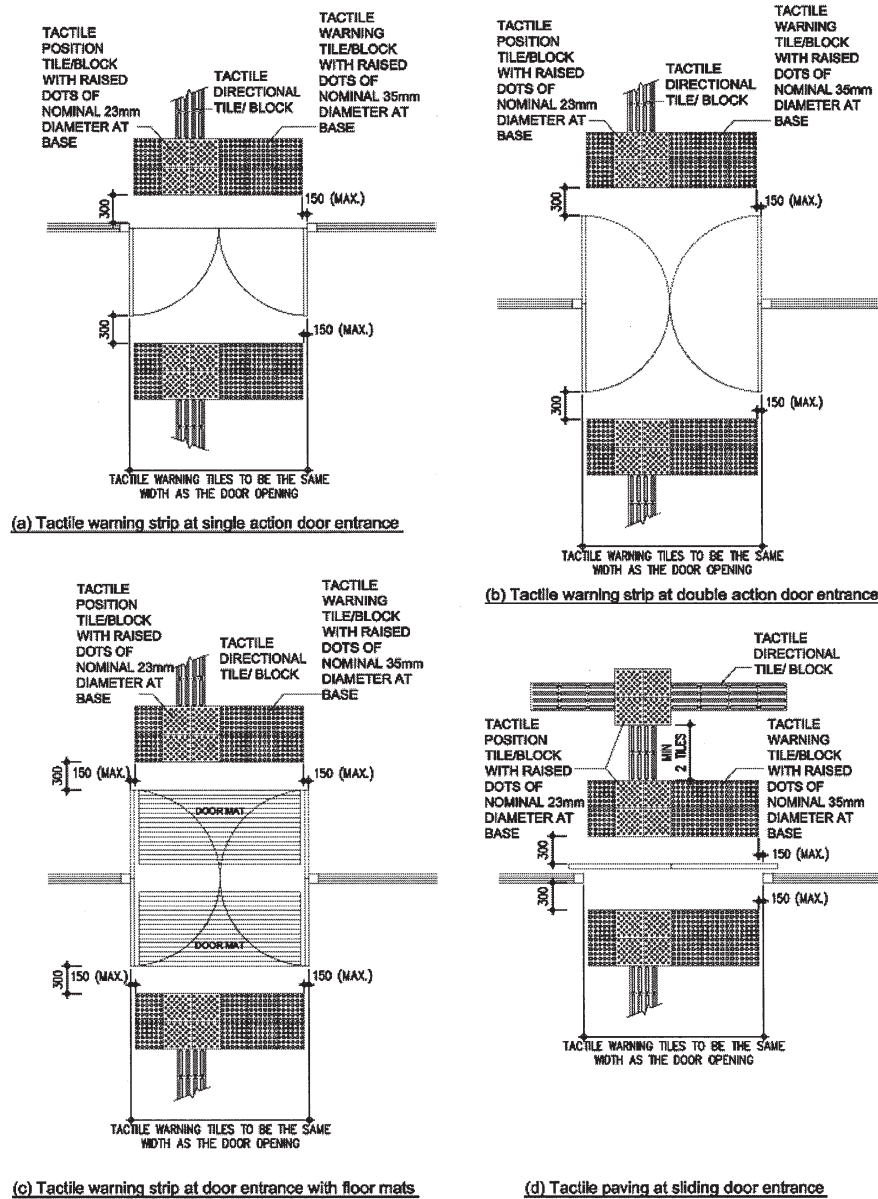

*ALL DIMENSIONS ARE IN mm

Tactile guide paths on access routes.

FIGURE NO. 5

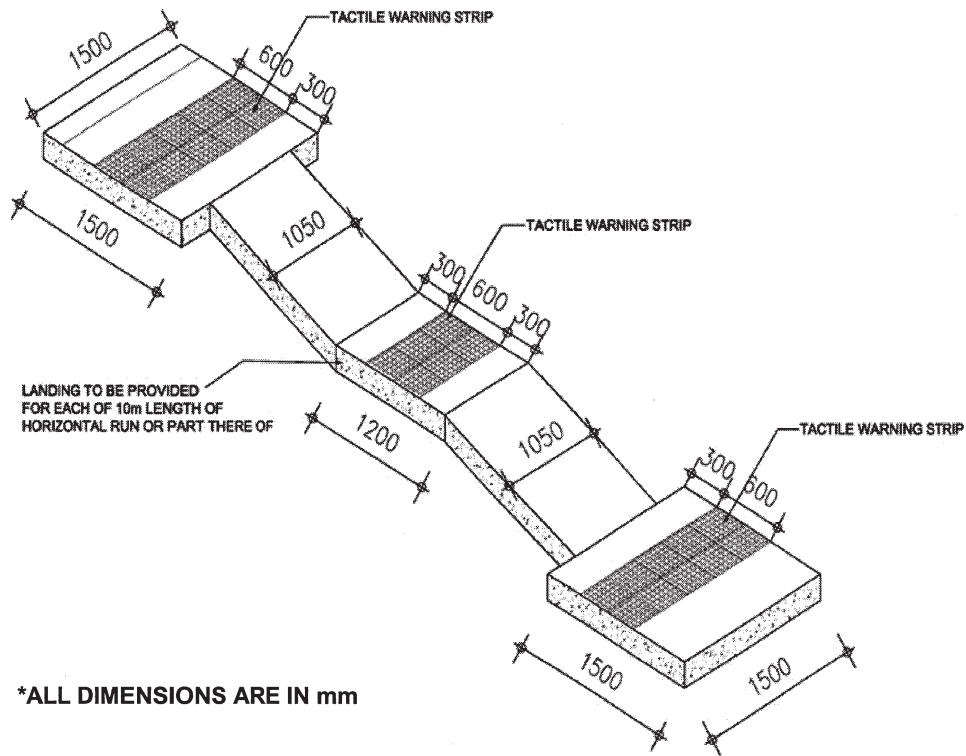

Tactile warning strips for ramps.

FIGURE No. 6

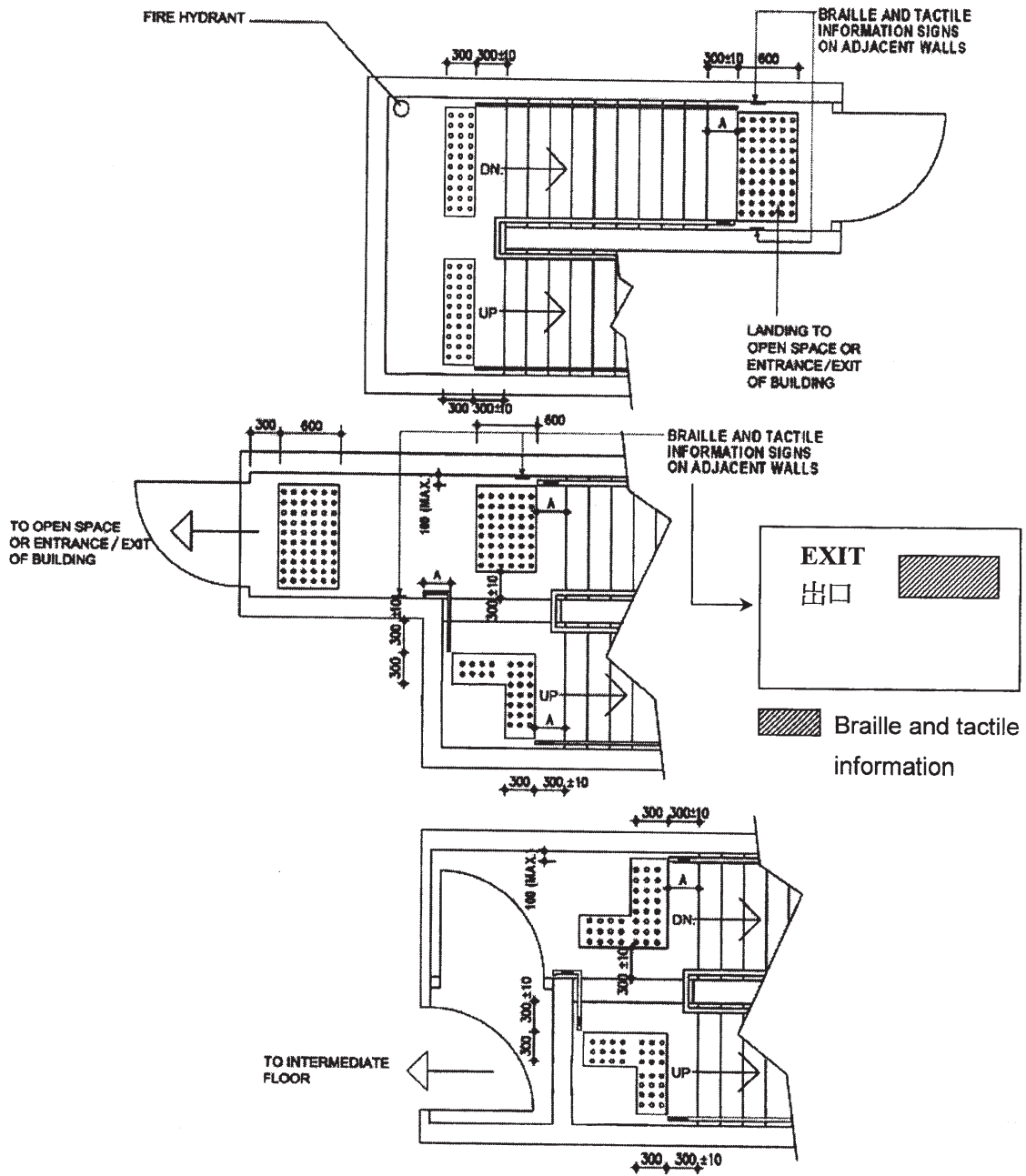

LEGEND: A - MIN. 300 HORIZONTAL HANDRAIL EXTENSION

■ - BRAILLE AND TACTILE INFORMATION INCLUDING DIRECTIONAL ARROW, FLOOR NUMBER AND INFORMATION SIGN

▤ - TACTILE WARNING STRIP

*ALL DIMENSIONS ARE IN mm

Tactile warning strips for staircases.

FIGURE NO. 7



Gridlines are provided to show the proportion only

International symbol for access for hearing loss.

FIGURE NO. 8

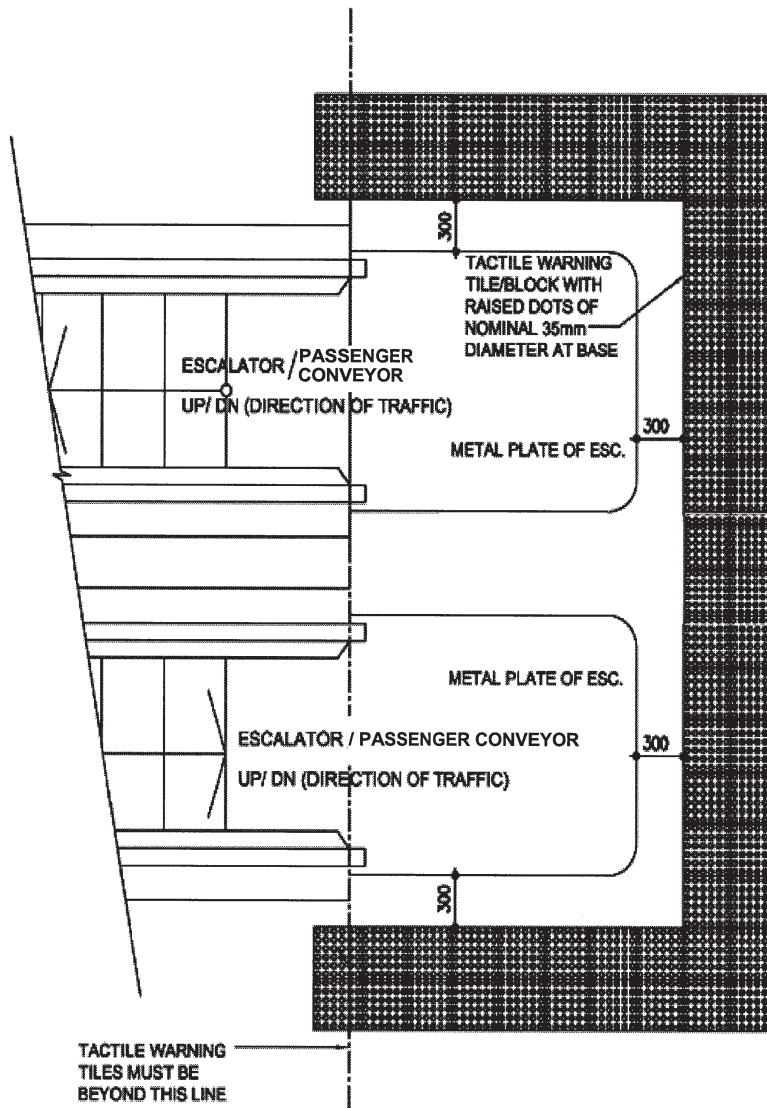

*ALL DIMENSIONS ARE IN mm

Tactile warning strips for escalators or passenger conveyors.

PART 4

BUILDING WHERE LIMITED FACILITIES FOR PERSONS WITH A
DISABILITY ARE TO BE PROVIDED

Category of Buildings	Extent of application of regulation 72
1. Domestic buildings	<p>(a) All common areas of such buildings of more than 4 storeys.</p> <p>(b) Main entrance and common areas of the ground floor and means of access to buildings which do not exceed 4 storeys.</p> <p>(c) The areas mentioned in paragraphs (a) and (b) shall not include the parts of the building used for the following purposes—</p> <ul style="list-style-type: none">(i) areas only used for building services and maintenance (testing, inspections, verification, repair and overhaul) including—<ul style="list-style-type: none">(A) a plant, cooling tower and power plant;(B) equipment and lift motor room, and electrical transformer room and switch room, a battery room, a machinery room, a plant room and a pump room;(C) a boiler room;(D) non-tenantable spaces accessed only by ladders, catwalks or crawl spaces;(E) an access route for maintenance, pits, lift shafts and ventilation shafts; and(F) a sub-station, telecommunications equipment room, metering area or the like;(ii) mezzanine floor used only for storage, plant and equipment installations or the like;(iii) raised platform used primarily for the purposes of security or safety management, including but not limited to, guard tower or fixed lifeguard stand;(iv) swimming pool (the water-containing pool only); and(v) any path providing access only to an area used for the purposes as stated in subparagraphs (i) to (iv) above.
2. Non-domestic buildings	All parts of such buildings, excluding the parts used for the following purposes—

Category of
Buildings

Extent of application of regulation 72

- (a) commercial kitchen, cold room and cinema projector room;
 - (b) areas only used for building services and maintenance (testing, inspections, verification, repair and overhaul) including—
 - (i) a plant, cooling tower and power plant;
 - (ii) equipment and lift motor room, and electrical transformer room and switch room, a battery room, a machinery room, a plant room and a pump room;
 - (iii) a boiler room;
 - (iv) non-tenantable spaces accessed only by ladders, catwalks or crawl spaces;
 - (v) an access route for maintenance, pits, lift shafts and ventilation shafts; and
 - (vi) a sub-station, telecommunications equipment room, metering area or the like;
 - (c) areas used for storage of raw materials or produce or for bulk storage where—
 - (i) the stored materials are hazardous; or
 - (ii) the public is not permitted to enter, such as waste containment area, chemical store or the like;
 - (d) mezzanine floor used only for storage, plant and equipment installations or the like;
 - (e) raised platform used primarily for the purposes of security or safety management, including but not limited to, guard tower or fixed lifeguard stand;
 - (f) swimming pool (the water-containing pools only); and
 - (g) any path providing access only to an area used for the purposes as stated in paragraphs (a) to (f) above.
3. Composite buildings
- (a) All common areas of the domestic parts of such buildings if the domestic parts are more than 4 storeys.
 - (b) Main entrance and common areas of the ground floor and means of access to buildings if the domestic parts of which do not exceed 4 storeys.

Category of
Buildings

Extent of application of regulation 72

- (c) The areas mentioned in paragraphs (a) and (b) shall not include the parts of the building used for the following purposes—
- (i) areas only used for building services and maintenance (testing, inspections, verification, repair and overhaul) including—
 - (A) a plant, cooling tower and power plant;
 - (B) equipment and lift motor room, and electrical transformer room and switch room, a battery room, a machinery room, a plant room and a pump room;
 - (C) a boiler room;
 - (D) non-tenantable spaces accessed only by ladders, catwalks or crawl spaces;
 - (E) an access route for maintenance, pits, lift shafts and ventilation shafts; and
 - (F) a sub-station, telecommunications equipment room, metering area or the like;
 - (ii) mezzanine floor used only for storage, plant and equipment installations or the like;
 - (iii) raised platform used primarily for the purposes of security or safety management, including but not limited to, guard tower or fixed lifeguard stand;
 - (iv) swimming pool (the water-containing pool only); and
 - (v) any path providing access only to an area used for the purposes as stated in subparagraphs (i) to (iv) above.
- (d) All non-domestic parts of such buildings, excluding the parts used for the following purposes—
- (i) commercial kitchen, cold room and cinema projector room;
 - (ii) areas only used for building services and maintenance (testing, inspections, verification, repair and overhaul) including—
 - (A) a plant, cooling tower and power plant;
 - (B) equipment and lift motor room, and electrical transformer room and switch room, a battery room, a machinery room, a plant room and a pump room;

Category of
Buildings

Extent of application of regulation 72

- (C) a boiler room;
- (D) non-tenantable spaces accessed only by ladders, catwalks or crawl spaces;
- (E) an access route for maintenance, pits, lift shafts and ventilation shafts; and
- (F) a sub-station, telecommunications equipment room, metering area or the like;
- (iii) areas used for storage of raw materials or produce or for bulk storage where—
 - (A) the stored materials are hazardous; or
 - (B) the public is not permitted to enter, such as waste containment area, chemical store or the like;
- (iv) mezzanine floor used only for storage, plant and equipment installations or the like;
- (v) raised platform used primarily for the purposes of security or safety management, including but not limited to, guard tower or fixed lifeguard stand;
- (vi) swimming pool (the water-containing pools only); and
- (vii) any path providing access only to an area used for the purposes as stated in subparagraphs (i) to (vi) above.”.

Carrie LAM

Secretary for Development

10 May 2008

Explanatory Note

This Regulation amends the Building (Planning) Regulations (Cap. 123 sub. leg. F) to modify the existing requirements governing the provision of facilities in certain buildings to allow access to and use of such buildings and their facilities by persons with a disability. The amendments are made to provide for the relevant revised requirements as set out in a design manual entitled “Design Manual: Barrier Free Access 2008”, which was finalized in November 2007 after consultation with the stakeholders, the industry and the Legislative Council Panel on Welfare Services.