

469CL號工程計劃 – 啟德發展計劃 – 啟德機場北面停機坪的基礎設施及 啟德發展計劃進度報告

2016年2月

PWP Item No. 469CL – Kai Tak Development – Infrastructure at North Apron
Area of Kai Tak Airport and Progress Report on Kai Tak Development
February 2016





啟德發展計劃進度報告

Progress Report on Kai Tak Development

啟德發展區發展進程

KTD – Development Progress

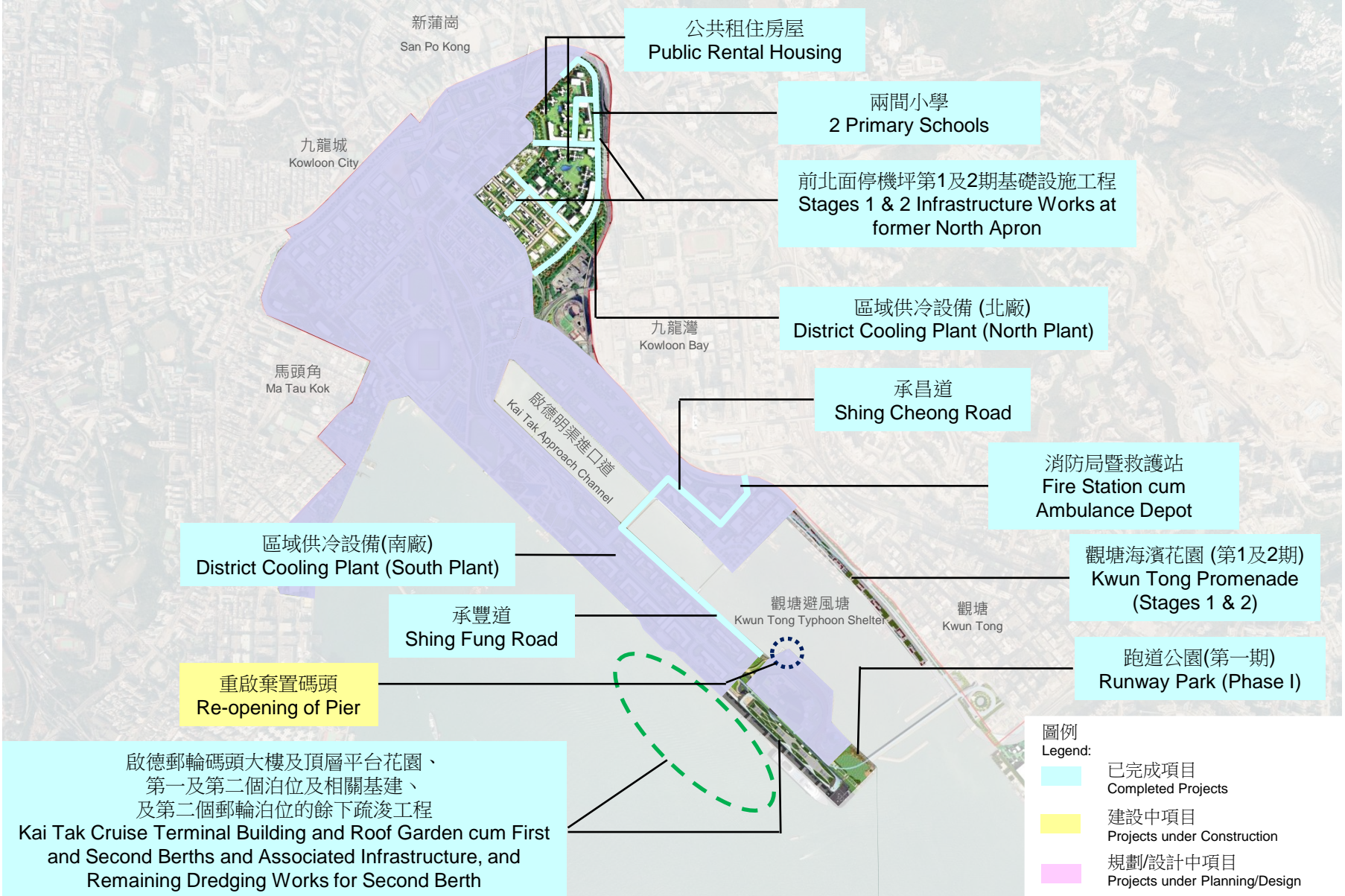

啟德發展區發展進程

KTD – Development Progress



工業貿易大樓
Trade and Industrial Tower

前北面停機坪第3A期基礎設施工程
及相關區域供冷管道
Stage 3A Infrastructure Works at
former North Apron and Associated
District Cooling Mains

啟德明渠重建及改善工程
Reconstruction and Upgrading of
Kai Tak Nullah

前跑道南面發展項目第3期基礎設施工程
及相關區域供冷管道
Stage 3 Infrastructure Works for Developments at
the Southern Part of the Former Runway and
Associated District Cooling Mains

前北面停機坪第4期基礎設施工程
及相關區域供冷管道
Stage 4 Infrastructure Works
former North Apron and
Associated District Cooling Mains

香港兒童醫院
Hong Kong Children's Hospital

前跑道南面發展項目第2期基礎設施工程
及相關區域供冷管道
Stage 2 Infrastructure Works for Developments at
the Southern Part of the Former Runway and
Associated District Cooling Mains

啟德明渠進口道及
觀塘避風塘改善工程(第一期)
Improvement Works at Kai Tak
Approach Channel and Kwun
Tong Typhoon Shelter (Phase 1)

- 圖例
Legend:
- 已完成項目
Completed Projects
 - 建設中項目
Projects under Construction
 - 規劃/設計中項目
Projects under Planning/Design

啟德發展區發展進程

KTD – Development Progress

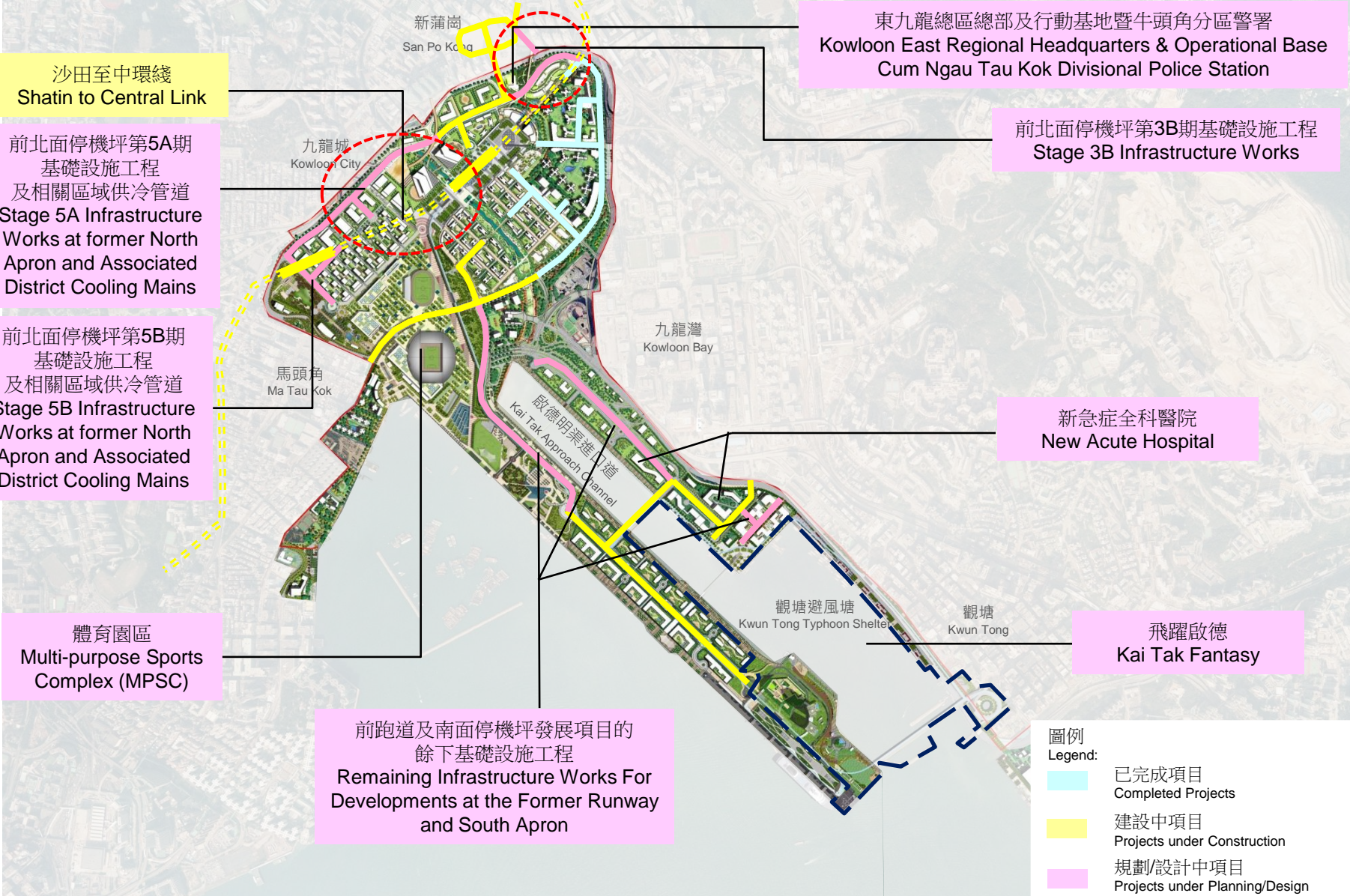

沙田至中環綫
Shatin to Central Link

前北面停機坪第5A期
基礎設施工程
及相關區域供冷管道
Stage 5A Infrastructure
Works at former North
Apron and Associated
District Cooling Mains

前北面停機坪第5B期
基礎設施工程
及相關區域供冷管道
Stage 5B Infrastructure
Works at former North
Apron and Associated
District Cooling Mains

體育園區
Multi-purpose Sports
Complex (MPSC)

前跑道及南面停機坪發展項目的
餘下基礎設施工程
Remaining Infrastructure Works For
Developments at the Former Runway
and South Apron

東九龍總區總部及行動基地暨牛頭角分區警署
Kowloon East Regional Headquarters & Operational Base
Cum Ngau Tau Kok Divisional Police Station

前北面停機坪第3B期基礎設施工程
Stage 3B Infrastructure Works

新急症全科醫院
New Acute Hospital

飛躍啟德
Kai Tak Fantasy

- 圖例
Legend:
- 已完成項目
Completed Projects
 - 建設中項目
Projects under Construction
 - 規劃/設計中項目
Projects under Planning/Design

啟德發展區發展進程

KTD – Development Progress

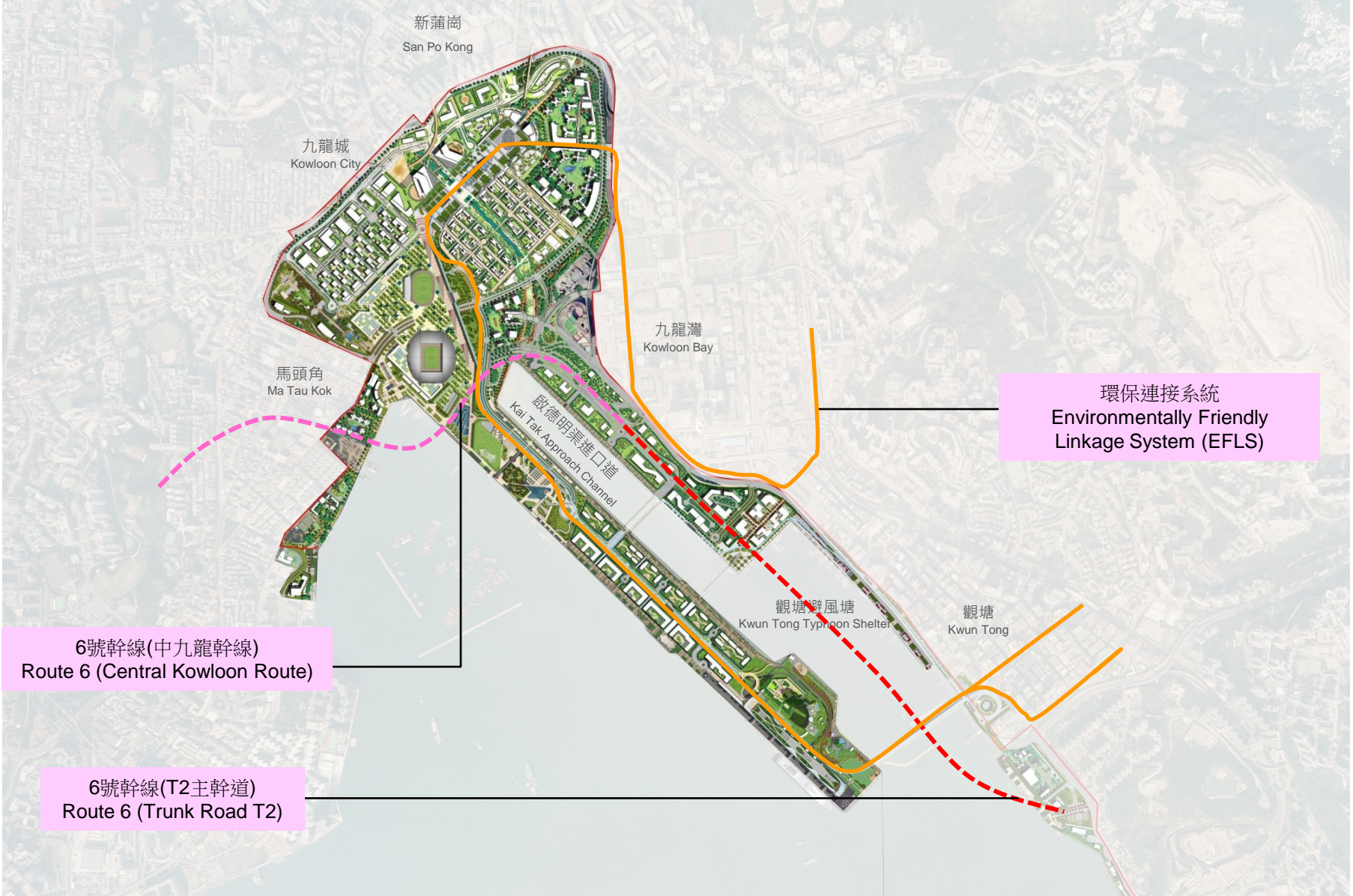

6號幹線(中九龍幹線)
Route 6 (Central Kowloon Route)

6號幹線(T2主幹道)
Route 6 (Trunk Road T2)

環保連接系統
Environmentally Friendly
Linkage System (EFLS)



469CL號工程計劃 – 啟德發展計劃
– 啟德機場北面停機坪的基礎設施
PWP Item No. 469CL – Kai Tak Development
– Infrastructure at North Apron Area of Kai Tak Airport

469CL號工程計劃的基礎設施工程 – 第3B期基礎設施工程

Infrastructure works under PWP Item No. 469CL – Stage 3B Infrastructure Works

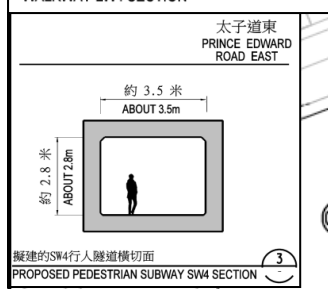
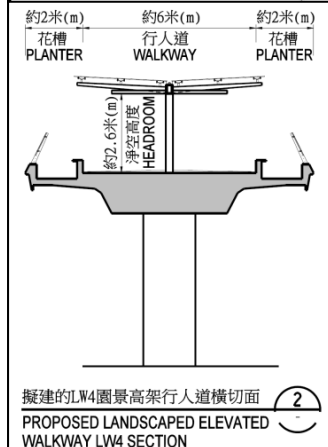
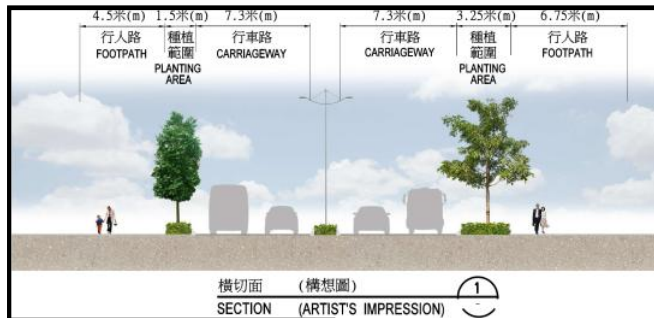
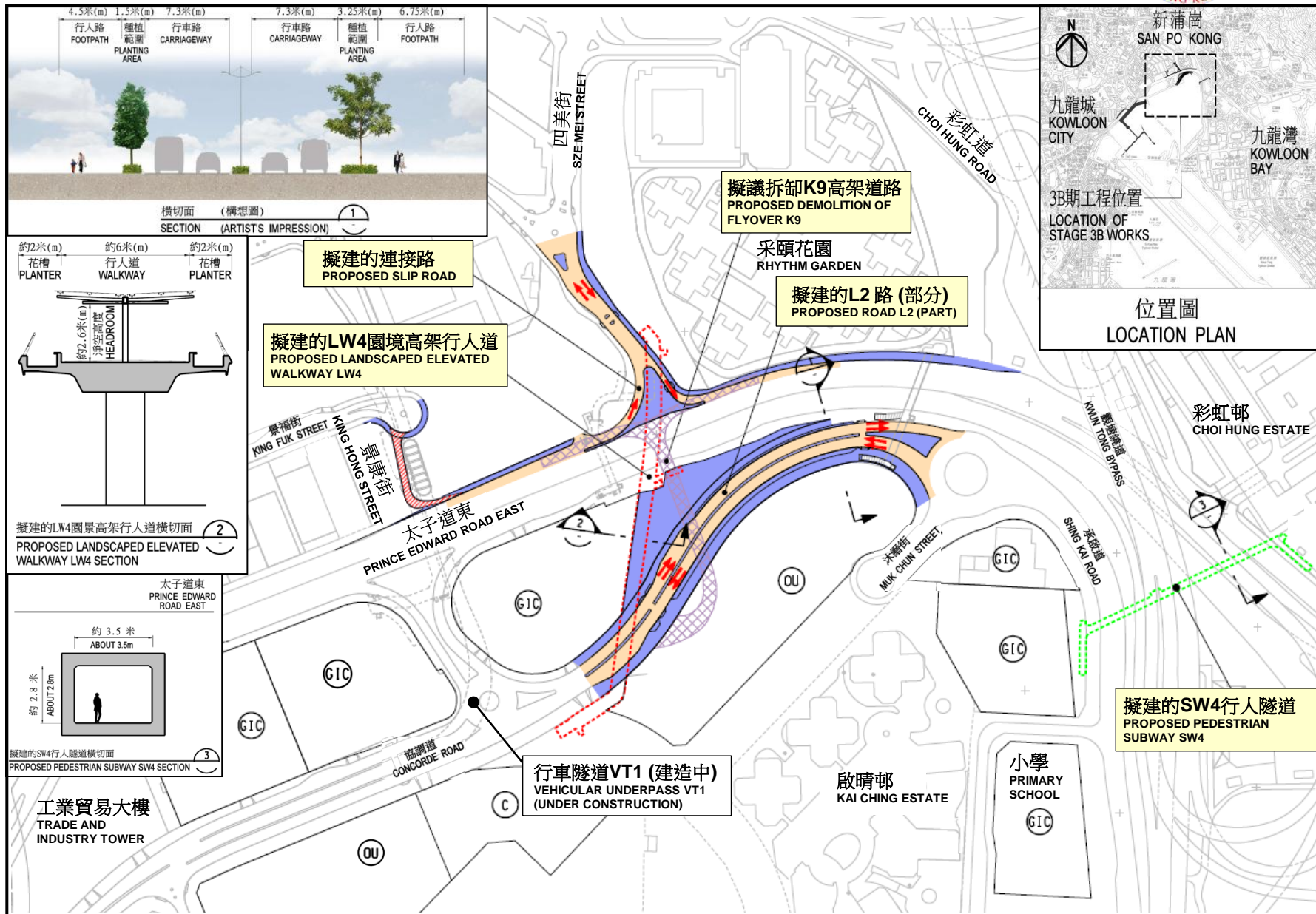

469CL號工程計劃的基礎設施工程 – 第5A期基礎設施工程

Infrastructure works under PWP Item No. 469CL – Stage 5A Infrastructure Works

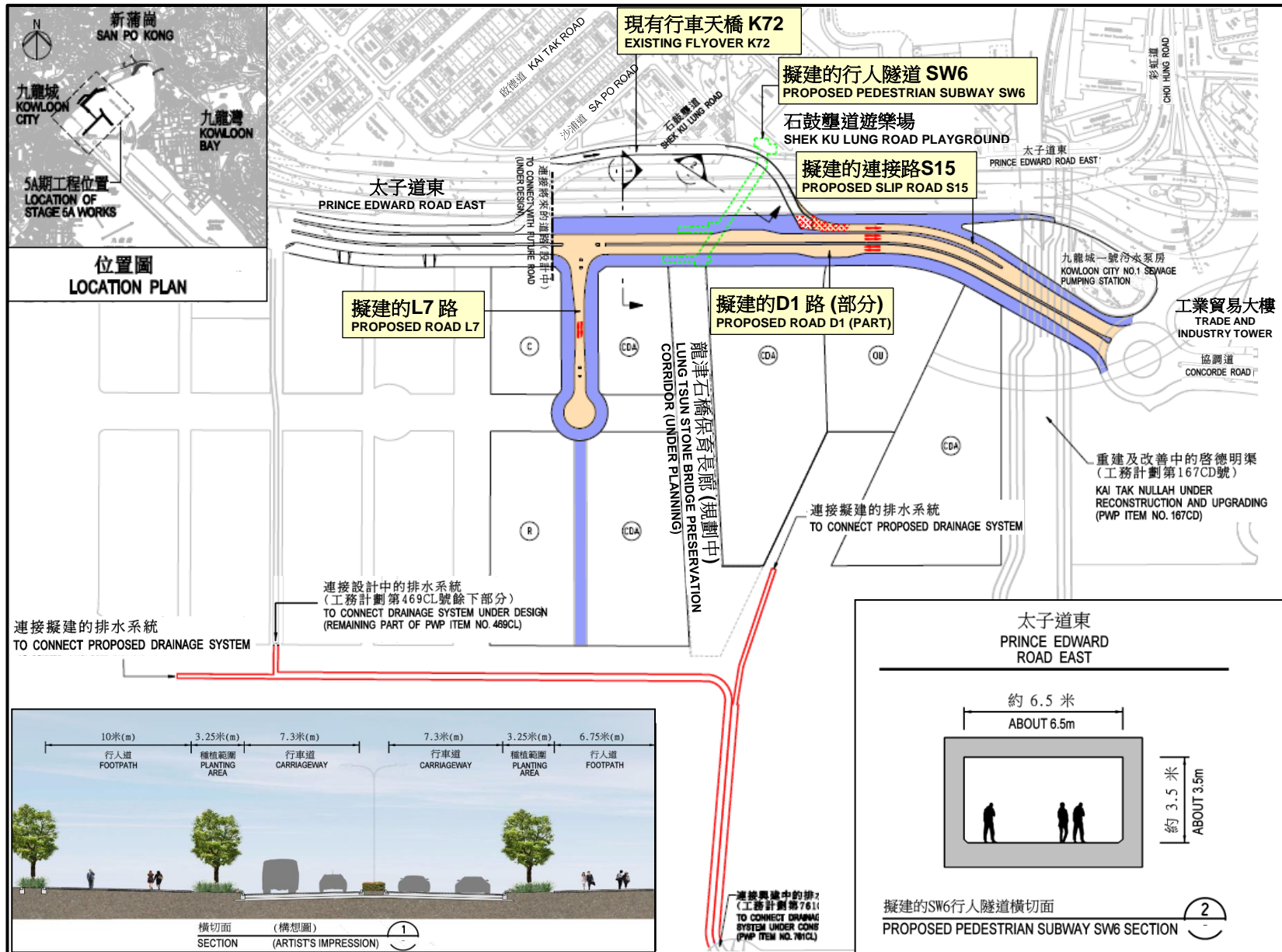

469CL號工程計劃工程分項費用

Cost breakdown of PWP Item No. 469CL



項目 Items	預計費用 (百萬元) Estimated Cost (\$ million)
道路工程 Road works	360
園景高架行人道 Landscaped elevated walkway	240
行人隧道 Pedestrian subways	400
排水系統、排污系統、水管及附屬工程 Drainage, sewerage, water mains and ancillary works	360
相關工程包括環境美化工程 Associated works including landscaping works	70
緩解環境影響措施及環境監察及審核計劃 Environmental mitigation measures and environmental monitoring & audit programme	20
顧問費及駐工地人員的薪酬 Consultants' fees and remuneration of resident site staff	160
應急費用 Contingencies	160
價格調整準備 Price adjustment	430
合共Total	2,200

469CL號工程計劃

「啟德發展計劃 - 啟德機場北面停機坪的基礎設施」

PWP Item No. 469CL

“Kai Tak development – Infrastructure at North Apron Area of Kai Tak Airport”



程序 Tasks	時間表 Programme
申請撥款 Funding Application	2016年 上半年 First half of 2016
工程展開 Commencement of Works	2016年 第3季 Q3 2016
最後一期工程完成 Completion of Last Section of Works	2020年 2020



發展局

土木工程拓展署

Development Bureau

Civil Engineering and Development Department

致力締造完美新啟德

Dedicated to the success of Kai Tak Development



謝謝
Thank you

