

全香港影視製作用槍械經營人

就

1999 年火器及彈藥（修訂）條例草案

回應及意見書

致：立法會 1999 年火器及彈藥（修訂）條例草案委員會

由：全香港影視製作用槍械經營人
代表公司：寶力道具有限公司

Hollywood Film Service Company
Film Tech Prop Services Ltd.
Combat Theatre Ltd.

日期：1999 年 3 月 25 日

事由：就 3 月 5 日各委員與保安局會議回應

議員閣下，

立法會專責委員會就保安局提交 1999 年火器及彈藥（修訂）條例草案一事，在 3 月 5 日與保安局，警方及律政署等多位代表進行了一次會議。我們有幸出席旁聽，而多位議員也就提案中多項疑問及影/視業界內的憂慮提出質詢。但保安局及警方的回答大都迴避了修訂對影/視製作用槍械業影響的問題，祇是重覆的以‘公眾安全’及‘防範於未然’為理由，強調槍械的危險性，把製作用槍械與射擊用槍械混為一談，實有欠公允。

現我就當日議員們的關心提問及保安局等回答，提出意見如下：

1. 問： 委員會主席涂謹申議員問保安局欲修訂法例的原因？是否有記錄到嚴重事故發生？因為他收到 2 批人仕反對，並問保安局有否向各有關團體加以諮詢？
答： 保安局回答是以‘公眾安全及防範於未然’為理由要求修訂法例，但他們同意並沒有記錄曾有嚴重時故發生。而政府在 1996 年初曾就 1996 修訂草案向部份人仕提出諮詢，之後沒有再做。因為他們認為就算 1999 年修訂草案獲得通過，也打算以一年時間去做預備工夫。
意見： 1996 年之會面，祇是在銅鑼灣警官俱樂部以非正式會談進行，會談議程與影/視製作業完全無關。連會議記錄也欠奉。而當時提供參考之 1996 年火器及彈藥（修訂）條例草案內也沒有加入對影/視業不合理的的條文。例如在 1999 年新草案第 2 條中建議廢除‘發射’而代以‘鳴響’。意圖更改‘槍械’釋義。（請參考附頁 A - 1996 年火器及彈藥

(修訂) 條例草案，邀請函及會談議題)

2. 問：程介南議員提出他見不到有持牌人濫用槍械事故發生，保安局不能濫用‘公眾安全’一詞而亂加管制。政府也要照顧及尊重射擊運動員，持牌槍械經營人及影/視業界的權益。

答：保安局同意他們要與各有關團體交換意見，不可以閉門造車。

意見：業界及有關人仕曾在 1996 年的諮詢中提出反對意見。並列舉多項原因及對業界的影響。但政府對業內的意見，運作及生存能力沒有加以考慮，對影/視製作用槍械的改裝結構也沒有深入了解，完全漠視業界的生存空間和發展的權利。

3. 問：楊孝華議員再質詢保安局既說修訂條例是預防性的，但射擊用槍械及影視製作用槍械曾否被濫用或失去？

答：保安局回答是‘未有發生過’。

意見：政府不能用有色眼鏡或‘**Presumption of Guilty**’的態度去管治守法市民和合法生意經營人。憑空想象一些從沒有發生過或數據支持的事情，造成一種自我恐慌，而胡亂更改一套行之有效的機制。對雙方面祇會造成損害及困擾。

4. 問：馬逢國議員提出惶論新修訂草案，據他從業界內查詢所得，現行法例及警方之行政措施，已經大有問題，需要改善。例如限制電影使用槍械數量，妨礙創作自由。豁免証也由每一部製作改為每一個用槍演員，增加製作成本。他詢問警方曾否就意欲改變條例之細則及影響，向業界諮詢及聽取意見？例如該建議及運作是否可行？

答：警方答謂有武器訓練科及軍械法證科等部門，其武器訓練科人員每天不停訓練警務人員作射擊練習，以應付罪惡。如果他們技術有問題，則整個警隊訓練有問題。另外軍械法証科也會大量撥款，擁有先進儀器。應該沒有問題。至於限制影視製作使用槍械數量，則可以斟酌更改。

意見：這是很嚴重的錯誤。警方盡量迴避對影/視界影響這方向。他們看來對影視製作用槍械的使用目的，方法及其結構也有誤解，把射擊用槍械與製作用槍械完全混淆。我們同意香港擁有一支龐大的警隊及經驗豐富的武器射擊訓練人員，法證科也擁有大量先進器材，但因雙方的使用對象及目的不同，訓練方式與安全要求也因而有異。例如：訓練警員真槍實彈射擊，訓練人員除要求警員懂得該槍械之性能能及結構外，其射擊技術水平及現場環境。也要警員作出不同之決定。而訓練場地(靶場)內，各項安全裝設要求及預防措施也與影視製作不同。而鑑証科雖擁有大量先進器材及受槍械常識訓練，但化驗的目標大多是犯案的真實槍械或為警方作研究。

而影視製作用槍械則是另一門學問，由於商業需求，經營人從世界各地搜購，種類繁多。任何一個政府機構也沒有可能為此提供訓練。影/視製作並不需要向真實的目標射擊，要求的祇是一個幻覺效果，螢光幕上的一連串槍擊動作場面，是經過導演及指導們精心設計及創作而成。演員祇需要依從導演的指示，做出種種高難度及美觀的動作，務求以逼真及震撼效果令觀眾甚至警方相信演員們是近距離向對方射擊。而每個參予製作的影視工作人員都知道及明白安全操作的重要性，當使用製作用槍械時都會盡量以角度遷就，或單獨拍攝個人動作後剪輯而成。若警方不明白影視製作程序，單從其實彈射擊安全觀念，代入震撼的電影視覺效果，則會容易產生誤會。作出不合理決定。

5. 問：程介南議員堅持政府必須支持合法商業經營及射擊體育活動，立法的目的不能祇為控制人民而設。
- 答：保安局同意會以合情合理為基礎，從最小必須的安全需要而修訂。例如限制影視製作用槍械數量一項，是可以商討。
- 意見：所謂基礎及最小需要而修訂，都是為配合己方要求而單方面決定。業界或被管者的意見從不見被尊重或考慮。例如在 **1996** 年諮詢文件及非正式會談中，影/視製作業有關團體，如影視及娛樂事務管理處，影業協會，香港電影導演會，香港演藝人協會及電影製作發行協會等。都並未列入在意見諮詢名單內，反而沒有使用製作用槍械之‘**STAR TV**’及‘演藝學院’被邀請出席。可見修訂草案小組對影視製作業的運作及結構完全陌生及誤解。雖然當年會談議題完全與影視製作用槍械無關及有關團體未被邀請，但個別經營人及關心人仕也就要求每年重新覆驗之建議提出充分理據，曾作書面反對。強調其部份建議內容是不合理及不可行的。並要求當時保安科重新研究。但可惜的是政府並沒有珍惜業內所提的寶貴意見，近年來單方面接連以行政措施，管制影視製作用槍械的使用。更在 **3** 年後提交之 **1999** 火器及彈藥（修訂）條例草案第 **2** 條中，建議把‘鳴響’代替‘發射’意圖更改‘槍械’釋義。現附上 **1996** 年會議之受邀名單及議程以供參考。（附頁 **B**）
6. 問：委員會主席涂謹申議員要求演藝界指出警方槍械牌照科之不合理措施及是否濫用權力。
- 答：警方回答影視界問題可以透過協商解決。
- 意見：雖然在新修訂草案中並不見到有直接提及管制影視製作用槍械之條文，但警方一直以來藉現條例 **238** 章第 **52** 條賦予警務處長的權力，以行政手法執行不合理措施。例如 **4** 年前開始限制影視製作用槍械數量，去年又突然禁止使用批准了 **12** 年的散彈槍作影視製作，及豁免牌照由每部電影申請改為每名演員申請，令成本增加。今年又建議已檢驗合格的製

作用槍械作無謂的覆驗等等。以往基於香港電影製作時限短速，無暇提出申訴而被迫接受。現希望能借此次修訂法例機會，政府能參考各歐美先進國家之檢驗及發牌制度，把製作用槍械在法例中從新釋義，規定每一枝新改裝完成的影視製作用槍械，在批准使用前，都必須經過警方軍火專家安全測試，若檢驗合格，則交予影視及娛樂處等專責部門作跟進管理。

7. 問： 馬逢國議員問根據現行法例第 238 章第 2 條中對‘槍械’的定義是槍口發射能量超過 2 焦耳，才定為有危險性及受管制。但影視製作用槍械已改裝到完全不能發射子彈/投射物，能否重新定義或可否豁免為‘非槍械’？

答： 不可能。因 2 焦耳祇是用於量度氣槍。並不適用於真槍。而影視製作用槍械能發射空彈，有發射功能。故是真槍。

意見： 警方的根據是錯的。焦耳是一種能量量度單位，一焦耳等如移動一公斤重物質往一米距離所需的能量。并不單止適用於氣槍，所有能產生投射物之槍械也可以用來衡量。故槍彈也是以焦耳計算其殺傷能量。例如發射一粒零點 22 小口徑子彈有 130-190 焦耳，而一般警用左輪手槍發射之零點 38 口徑子彈則有 250-335 焦耳。（附頁 C—彈藥生產商目錄）。我們同意製作用槍械有發射空彈功能，藉此製造螢幕上的視覺效果。但空彈並不是一種如傳統概念，能發射投射物（俗稱子彈）而傷人。它祇可以產生一種‘聲響’及視覺效果，貿易處及香港海關也把空彈界定為非戰略性物品，不需要進出口管制。（請參考附頁 D—香港政府貿易署文件）歐美國家更可以隨意擁有。如香港能仿效外國般把空彈界定為危險品而非彈藥類。則影視製作用槍械可以豁免為‘非槍械’及交由影視及娛樂處管理。現時空彈的運送及使用記錄，已受土木工程署礦務科以危險品發牌登記及嚴格管理。根本不需要再受警方以彈藥類重疊監管。圖然浪費人手。故保安局並不需要修改 238 章第 2 條之釋義。把祇可以製造‘鳴響’之器械也納入不適當監管。反而可以把改裝完成及檢驗合格的影視製作用槍械從第 238 章中申明，豁免為‘非槍械’。

8. 問： 馬逢國議員再問是否警方以為影視製作用槍械有可能回復發射實彈功能而把製作用槍械決定為真槍？

答： 杜警司回答影視製作用槍械為真槍改裝，而空彈也歸類為子彈。發射時有氣流產生，在近距離發射對人體有傷害。而這些槍很容易改裝回原裝槍械，故必須被視為真槍。

意見： 警方的觀念是錯誤的，首先空彈的原理及能否界定為子彈是可以爭議。我們在第 6 項中已提出論據。若害怕在近距離發射時所產生的氣流可

以傷人，那‘傷人’的定義將會很模糊。我們不能把拍攝時因該槍械所帶來的每一種工業意外如夾傷，趾傷或燙傷都歸究於製作用槍械的不安全，每一個有經驗的導演，槍械指導甚至攝影師都明白及知道近距離發射所產生氣流的危險，而改用拍攝角度或剪接遷就。請參考一份由影娛處轉達美國荷李活使用影視製作用槍械時之安全守則。（附頁 **E**）此守則清楚列出所有拍攝工作時有可能發生之危險及預防措施

影視製作用槍械最初確是由真槍改裝而成，但一旦被改裝完成後，此槍械就必須不能再發射真彈。此要求自 **1987** 年第一個經營人牌照批出以來，一直作為警方軍火專家所依據之標準，若有任何不完善，都會退回作重新改裝。（請參考附頁 **F**-牌照科之通知文件申明其要求）。故並不能因政府部門人事變動，或對影視界的態度改變，而把過去 **12** 年來同一個警方軍火專家部門所作出的決定推翻。由同意不能改回發射功能而變為容易改回真槍。這改變是完全沒有根據的。因為製作用槍械所需要改裝的位置，都是組成一件槍械的必須部份，在手槍類別中則包括槍管及滑架。此類主要組件一旦改裝完成，就絕不可能再供實彈發射使用。若強行解說可以改裝，祇能是把一些餘下但仍然適用的配件取出，再重新與另一些主零件配合裝嵌而成另一支槍械。但這與原製作用槍械無關。況且不論任何數量或種類的槍械主零件，均被列為戰略物資，在任何一個國家也受嚴格的進出口管制，並不能如想象中的隨手可得。

9. 問： 蔡素玉議員問氣流傷害有多大？一塊石頭若使用不當，也可以傷人。

答： 警方說不能具體回答。因為製作用槍械祇是改裝過的槍，故需要管。

10. 問： 馬逢國議員認為可以立法規定不能把製作用槍械更改回真槍，否則犯法，這樣就可以解除政府之疑慮。

答： 警方說一定要防止槍械流入社會。他們必須確保及預防影視製作用槍械不落在不法人仕手中。

意見： 雖然影視製作用槍械被改裝回射擊用槍械的機會微乎其微，但清楚立法規定不能把已批准的影視製作用槍械更改回有殺傷功能的真槍，既能增加阻嚇力量，也會解決保安局之憂慮，故是最佳辦法。

此類型槍械不使用時是儲存在保安嚴密的槍械庫，安全要求與儲存射擊用槍械相同。並不是四處胡亂擺放。每次出入及使用記錄都必須登記。當有電影欲使用該類型槍械製作時，演員及製片負責人員都預先向警方填報個人資料及申領使用豁免証。使用時間及地點也需要在 **3** 個工作天前向警方公共關係科以書面申請，整個運送及使用過程均由經營人公司所委派的技師沿途監視及保管。並不存在有不適合人仕參予。故流入不法分子手中機會甚微。而被盜或被重新改裝情況，從未發生過。

若警方對經營人公司誠信有質疑，經證實後可吊銷牌照及依法檢控。不能以行政手段阻礙合法商業活動。

總括整個修訂草案來說，我們支持政府就安全角度去施行考核制度，統一及強化工作人員的技術水平。但因使用情況與一般不同，政府必須先與業內人仕諮詢，詳細了解影視製作過程，才決定考核細則。絕不能以‘先通過’‘後研究’的態度進行。而每年重覆檢驗之建議，是完全不需要及不可行。這完全不能防止假設之流失或被非法誤用。在法理上，不能因人事變動或態度改變而否定前專家之決定。在經濟上，任何一個現有經營人也無法負擔，在此低迷經濟下，電影製作業正面臨困境，政府也不應再落井下石。

若能乘今次修訂法例之便，徹府的及明確的把影視製作用槍械從新釋義及把監管職權重新劃分。由警方負責安全檢驗及批准新改裝完成之槍械作影視製作用途，以後的申請及監管則交由影娛處跟進。那避免了警方有不合理措施及濫用權力之投訴。而考核工作人員一項，警方之武器訓練科也可匯同影娛處合作而成。因困撓多年之影視煙火爆破問題，也經由該處聯同礦務科及聘請專家而解決。希望以上意見能向議員們表達業內的擔憂和困境。

此致

立法局各議員

經營人代表

寶力道具有限公司－何應衡 (Tel: 2765-8266, Fax: 2363-6786)

Hollywood Film Service Company－潘志文 (Tel: 2364-6661. Fax: 2363-3482)

Film Tech Prop Services Ltd.－何孟強 (Tel: 2693-3231, Fax : 2601-5245)

Combat Theatre Ltd.－Fred Yau (Tel: 9081-9084,盆 Fax: 2651-6888)

副本送：

影視及娛樂事務管理處處長（經辦人：麥華雄先生）

資訊科技及廣播局局長（經辦人：蔡釰嫻女士）

香港影業協會（執行總幹事：叢運滋先生）

香港電影導演會（張同祖先生，陳嘉上先生，董瑋先生）

香港電影製作發行協會（舒達明先生）

演藝人協會（董瑋先生）

	<ul style="list-style-type: none">— 1996 年火器及彈葯（修訂）條例草案— 邀請函— 會議議題	1
		2
		3
		4
		5

附頁 A

皇家香港警察總部的信頭

本署檔號 OUR REF.: (38) in CP LIC CON 17/28/1 Pt. II

電話 TELEPHONE: 2860 2520 (Fax: 2866 2530)

內線 EXTENSION:

TELEX NO.: 65367 HX

15 May 1996

To : Distribution

Dear Sirs,

Discussion on Consultation Paper

You are invited to attend an informal discussion on the review of the Firearms and Ammunition Ordinance to be held at The Reading Room of the Police Officers' Club, Hung Hing Road, Causeway Bay, at 1430 hours on Tuesday 21 May 1996. A copy of the agenda for this discussion is attached.

Parking arrangements are available on the day of this meeting at the Police Officers' Clubs and a fee of HK\$20.00 per hour is payable for this facility.

I look forward to meeting you and to exchange our views at the meeting.

Yours Sincerely,

(AU Hok-lam)
Superintendent Licensing
for Commissioner of Police

...../Distribution

Ref. (35) in CP LIC CON 17/28/1 Pt. II

AGENDA FOR DISCUSSION WITH SHOOTING CLUBS

1. Test on applicants for firearms licence
2. Syllabus for the Test
3. Range standard
4. UK Proof House Certificates
5. Intending shooter be permitted access to firearms otherwise he cannot be instructed on the safe handling of firearms
6. “Agent or servant”
7. “Persons transiting HK whilst in possession of arms and ammunition”
8. Air Guns
 - Spring pistons
 - CO2 activated air guns
 - Possession of air soft gun in a public place



Legal Supplement No. 3

TO THE

**HONG KONG
GOVERNMENT GAZETTE**

Published by Authority

The attached Bills which are to be presented
to the Legislative Council at a future sitting are
published pursuant to Standing Order No. 40.

FRIDAY, 22 MARCH, 1996

SUP. TO GAZETTE No. 12 Vol. CXXXVIII

**FIREARMS AND AMMUNITION
(AMENDMENT) BILL 1996**

1996年火器及彈藥(修訂)條例草案

FIREARMS AND AMMUNITION (AMENDMENT) BILL 1996

CONTENTS

Clause		Page
1.	Short title and commencement	C504
2.	Interpretation	C504
3.	Possession on behalf of the Crown, etc.	C506
4.	Possession of arms or ammunition carried on aircraft	C506
5.	Possession by corporations, associations of persons, and members thereof	C506
6.	Possession for purposes of instruction	C508
7.	Section added	
	12A. Possession by agents and servants	C508
8.	Possession of arms or ammunition without licence	C510
9.	Resisting arrest with or committing offence while in possession of arms or ammunition or imitation firearms	C510
10.	Possession of an imitation firearm	C510
11.	Licences in respect of arms and ammunition	C510
12.	Section added	
	27A. Additional conditions in respect of shooting clubs	C512
13.	Effect of licence for possession	C512
14.	Effect of dealer's licence	C514
15.	Renewal of licences	C514
16.	Applicant or licensee to be notified of decision of Commissioner	C514
17.	Appeals	C516
18.	Commissioner to be notified of transactions, etc.	C516
19.	Dealers to record particulars of all transactions	C516
20.	Storage of arms, ammunition and imitation firearms by Commissioner	C516
21.	Sections added	
	46A. Armouries	C518
	46B. Shooting ranges	C518
	46C. Range officers	C518
22.	Regulations	C518
23.	Section substituted	
	54. Amendment of Schedules	C520
24.	Transitional provisions	C522
25.	Provisions to which sections 17(2) and 20(2) apply	C522
26.	Schedule added	
	Schedule 2 Shooting clubs	C522

1996年火器及彈藥(修訂)條例草案

目錄

條次		頁次
1.	簡稱及生效日期	C505
2.	釋義	C505
3.	代官方等管有	C507
4.	對飛機上攜帶的槍械或彈藥的管有	C507
5.	由法團、一人以上的組織及其中成員管有	C507
6.	為指導而管有	C509
7.	加入條文	
	12A. 由代理人及受僱人管有	C509
8.	無牌管有槍械或彈藥	C511
9.	以槍械或彈藥或仿製火器拒捕或犯罪時管有槍械或彈藥或仿製火器	C511
10.	仿製火器的管有	C511
11.	有關槍械及彈藥的牌照	C511
12.	加入條文	
	27A. 有關射擊會的附加條件	C513
13.	管有權牌照的效力	C513
14.	經營人牌照的效力	C515
15.	牌照的續期	C515
16.	申請人或持牌人獲通知處長的決定	C515
17.	上訴	C517
18.	處長須獲通知交易等	C517
19.	經營人須記錄一切交易詳情	C517
20.	由處長儲存槍械、彈藥及仿製火器	C517
21.	加入條文	
	46A. 槍械庫	C519
	46B. 射擊場	C519
	46C. 射擊場主任	C519
22.	規例	C519
23.	取代條文	
	54. 修訂附表	C521
24.	過渡性條文	C523
25.	第 17(2) 及 20(2) 條適用的條文	C523
26.	加入附表	
	附表 2 射擊會	C523

Clause		Page
	Summary Offences Ordinance	
27.	Interpretation	CS22
28.	Nuisances committed in public places, etc.	CS22

條次		頁次
	《簡易程序治罪條例》	
27.	釋義	CS23
28.	在公眾地方犯的妨擾罪等	CS23

A BILL To

Amend the Firearms and Ammunition Ordinance and to make a related amendment to the Summary Offences Ordinance.

Enacted by the Governor of Hong Kong, with the advice and consent of the Legislative Council thereof.

1. Short title and commencement

(1) This Ordinance may be cited as the Firearms and Ammunition (Amendment) Ordinance 1996.

(2) This Ordinance shall come into operation on a day to be appointed by the Secretary for Security by notice in the Gazette.

2. Interpretation

Section 2(1) of the Firearms and Ammunition Ordinance (Cap. 238) is amended by adding—

“agent or servant” means a person who is for the time being an agent or servant approved by the Commissioner under section 12A(2), and includes a prospective agent or servant but does not include any person employed as a security guard;

“appointment”, in relation to an agent or servant, includes employment;

“armoury” means any place, premises or other enclosed area specified as such by the Commissioner under section 46A;

“arms instructor” means a person authorized as such by the Commissioner under section 12(2), and includes a prospective arms instructor;

“corporation or unincorporated association of persons” means a corporation or an unincorporated association of persons referred to in section 11(2);

“own” includes hire or lease;

本條例草案 旨在

修訂《火器及彈藥條例》以及對《簡易程序治罪條例》作出有關的修訂。

由香港總督參照立法局意見並得該局同意而制定。

1. 簡稱及生效日期

(1) 本條例可引稱為《1996年火器及彈藥(修訂)條例》。

(2) 本條例自保安司以憲報公告指定的日期起實施。

2. 釋義

《火器及彈藥條例》(第238章)第2(1)條現予修訂，加入——

“代理人或受僱人”(agent or servant)指在當其時身為獲處長根據第12A(2)條批准的代理人或受僱人的人，並包括準代理人或準受僱人，但不包括受僱為保安護衛員的人；

“委任”(appointment)就代理人或受僱人而言，包括僱用；

“法團或一人以上的非法團組織”(corporation or unincorporated association of persons)指第11(2)條所提述的法團或一人以上的非法團組織；

“負責人員”(responsible officer)指屬第11(2)(c)條所述的負責人員的人；

“射擊場”(shooting range)指由處長根據第46B條指明為射擊場的任何地點或處所；

“射擊場主任”(range officer)指由處長根據第46C條批准為射擊場主任的人，並包括準射擊場主任；

“range officer” means a person approved as such by the Commissioner under section 46C, and includes a prospective range officer;
 “responsible officer” means a person described as such in section 11(2)(c);
 “responsible officer of a shooting club” means a responsible officer who—
 (a) in the case where the shooting club is a corporation, is a member of the board of directors of that corporation; or
 (b) in the case where the shooting club is an unincorporated association of persons, is a member of the management or executive committee (however described) of that club who holds the office for the time being of president (if any), chairman, vice-chairman or secretary,
 or in either case such other person who holds an office (however described) of that club and is personally responsible for the management of that club;
 “shooting club” means a corporation or an unincorporated association of persons specified in Schedule 2;
 “shooting range” means any place or premises specified as such by the Commissioner under section 46B;
 “terms and conditions” includes any additional or further terms and conditions.”.

3. Possession on behalf of the Crown, etc.

Section 3(b) is amended—

- (a) by repealing “or the Urban” and substituting “, the Urban Council or the Regional”;
- (b) by repealing subparagraph (i);
- (c) by adding—
 “(viii) the Agriculture and Fisheries Department;
 (ix) the Civil Aviation Department.”.

4. Possession of arms or ammunition carried on aircraft

Section 6(c)(i) is amended by adding “after” before “their”.

5. Possession by corporations, associations of persons, and members thereof

Section 11(2) is amended by adding—

“射擊會”(shooting club)指附表2所指明的法團或一人以上的非法團組織;
 “射擊會的負責人員”(responsible officer of a shooting club)指以下的負責人員——
 (a) 如該射擊會屬法團,則為該法團的董事局的成員;或
 (b) 如該射擊會屬一人以上的非法團組織,則為該射擊會的管理階層或執行委員會(不論稱謂如何)的成員並在當其時擔任會長(如有的話)、主席、副主席或秘書的職位的人,
 或在以上其中一種情況中擔任該會任何職位(不論稱謂如何)並由其個人負責該會的管理工作的其他人;
 “條款及條件”(terms and conditions)包括任何附加的或進一步施加的條款及條件;
 “槍械庫”(armoury)指由處長根據第46A條指明為槍械庫的任何地點、處所或其他圍封的範圍;
 “槍械導師”(arms instructor)指由處長根據第12(2)條授權為槍械導師的人,並包括準槍械導師;
 “擁有”(own)包括出租或租賃。”。

3. 代官方等管有

第3(b)條現予修訂——

- (a) 廢除“或市政局”而代以“、市政局或區域市政局”;
- (b) 廢除第(i)節;
- (c) 加入——
 “(viii) 漁農處;
 (ix) 民航處。”。

4. 對飛機上攜帶的槍械或彈藥的管有

第6(c)(i)條現予修訂,廢除“藥之前”而代以“藥之後”。

5. 由法團、一人以上的組織及其中成員管有

第11(2)條現予修訂,加入——

“(aa) he holds a licence for possession of arms or ammunition of the same class, type or description of arms or ammunition as those owned by the corporation or association, or he has completed or is undertaking a course of instruction under the supervision of an arms instructor in the safe use and handling of those arms and ammunition to the satisfaction of the Commissioner;”.

6. Possession for purposes of instruction

(1) Section 12 is renumbered as section 12(1).

(2) Section 12(1)(a) is amended by repealing “use” and substituting “safe use and handling”.

(3) Section 12(1)(c) is amended by adding “or an arms instructor” after “licensee”.

(4) Section 12 is amended by adding—

“(2) The Commissioner may upon the application of a licensee who holds a licence for possession, or that licensee’s agent or servant, as the case may be, authorize in writing the applicant as an arms instructor to instruct another person (including a person who intends to complete or undertake a course of instruction under section 11(2)(aa)) in the safe use and handling of arms and ammunition, and may attach such conditions to the written authorization (including a condition as to the duration of that authorization) as the Commissioner thinks fit.

(3) The Commissioner may at any time withdraw any written authorization given by him under subsection (2) to an arms instructor, or may vary or revoke any condition attached to that authorization or add any further condition.”.

7. Section added

The following is added—

“12A. Possession by agents and servants

(1) Sections 13 and 14 do not apply to the possession of, or dealing in, arms or ammunition by a person—

- (a) who is an agent or servant of a licensee who holds a licence for possession or a dealer’s licence;
- (b) who is carrying out the bona fide and lawful instructions of that licensee where those instructions relate to the duties, obligations and responsibilities of a licensee under this Ordinance; and
- (c) whose appointment as an agent or servant by the licensee is approved by the Commissioner under subsection (2).

“(aa) 該人持有與法團或組織所擁有的槍械或彈藥的類別、類型或種類相同的槍械或彈藥的管有權牌照，或該人已在槍械導師的監督下完成或正在參加一項有關該等槍械及彈藥的安全使用和處理的訓練課程，且成績令處長滿意；”。

6. 為指導而管有

(1) 第12條現予重訂為第12(1)條。

(2) 第12(1)(a)條現予修訂，廢除“使用”而代以“安全使用和處理”。

(3) 第12(1)(c)條現予修訂，在“持牌人”之後加入“或槍械導師”。

(4) 第12條現予修訂，加入——

“(2) 處長可在持有管有權牌照的持牌人提出申請後或在該持牌人的代理人或受僱人提出申請後(視屬何情況而定)，以書面授權申請人為槍械導師，使其可就有關槍械及彈藥的安全使用和處理指導另一人(包括擬完成或參加第11(2)(aa)條所指的訓練課程的人)，處長並可在該書面授權中附帶處長認為適當的條件(包括關於授權的持續期的條件)。

(3) 處長可在任何時間撤回他根據第(2)款給予槍械導師的任何書面授權，或可更改或撤銷該授權書所附帶的任何條件或增添任何其他條件。”。

7. 加入條文

現加入——

“12A. 由代理人及受僱人管有

(1) 凡任何人在以下情況下管有槍械或彈藥或經營槍械或彈藥，第13及14條不適用該項管有——

- (a) 該人是持有管有權牌照的持牌人的代理人或受僱人，或是持有經營人牌照的持牌人的代理人或受僱人；
- (b) 該人正在執行該持牌人的真誠及合法的指示，而該等指示是關於持牌人根據本條例所承擔的職責、義務及責任的；及
- (c) 該人獲持牌人委任為代理人或受僱人，是由處長根據第(2)款批准的。

(2) The Commissioner may at any time approve in writing the appointment by the licensee of the agent or servant referred to in subsection (1) to possess or deal in arms or ammunition and may attach such conditions to the written approval (including a condition as to the duration of the appointment of that agent or servant) as the Commissioner thinks fit.

(3) The Commissioner may at any time withdraw any written approval given by him under subsection (2) in respect of the appointment of a licensee's agent or servant, or may vary or revoke any condition attached to that approval or add any further condition."

8. Possession of arms or ammunition without licence

Section 13(1)(b) is repealed.

9. Resisting arrest with or committing offence while in possession of arms or ammunition or imitation firearms

Section 17(2) is amended by repealing "the Schedule" and substituting "Schedule 1".

10. Possession of an imitation firearm

Section 20(2) is amended by repealing "the Schedule" and substituting "Schedule 1".

11. Licences in respect of arms and ammunition

(1) Section 27(1) is amended by repealing "manner as may be prescribed" and substituting "containing such particulars as the Commissioner may from time to time specify".

(2) Section 27(4) is amended by adding ", including conditions imposing a limit or restriction on the number, class, type or description of arms, or the quantity, class, type or description of ammunition, or both, the subject of the licence" at the end.

(3) Section 27(5) is amended by repealing "the prescribed form" and substituting "such form and containing such particulars as the Commissioner may from time to time specify".

(2) 處長可在任何時間以書面批准持牌人委任第(1)款所提述的代理人或受僱人管有或經營槍械或彈藥，並可在該書面批准中附帶處長認為適當的條件(包括有關該代理人或受僱人的委任的持續期的條件)。

(3) 處長可在任何時間撤回他根據第(2)款就持牌人的代理人或受僱人的委任所給予的任何書面批准，或可更改或撤銷該批准書所附帶的任何條件或增添任何其他條件。"

8. 無牌管有槍械或彈藥

第13(1)(b)條現予廢除。

9. 以槍械或彈藥或仿製火器拒捕或犯罪時管有槍械或彈藥或仿製火器

第17(2)條現予修訂，在“附表”之後加入“1”。

10. 仿製火器的管有

第20(2)條現予修訂，在“附表”之後加入“1”。

11. 有關槍械及彈藥的牌照

(1) 第27(1)條現予修訂，廢除“須以”之後的所有字句而代以“處長不時指明的格式向處長提出，而申請書內須載有處長不時指明的詳情。”。

(2) 第27(4)條現予修訂，在末處加入“，包括對屬該牌照的標的之槍械的數目、類別、類型或種類，或對屬該牌照的標的之彈藥的數量、類別、類型或種類，或對兩者，施加限制或約束的條件”。

(3) 第27(5)條現予修訂，廢除“以”之後的所有字句而代以“處長不時指明的格式分別備存登記冊，而登記冊內須載有處長不時指明的詳情。”。

(4) Section 27 is amended by adding—

“(6) An application under this section for a licence for possession or an application for the renewal of such a licence under section 32 may be so made by—

- (a) a security guard; or
- (b) the responsible officer of a shooting club.”.

12. Section added

The following is added—

“27A. Additional conditions in respect of shooting clubs

(1) Notwithstanding section 11 and without limiting the general powers of the Commissioner under section 27, a licence for possession—

- (a) granted under that latter section to a licensee who is a responsible officer of a shooting club; and
- (b) expressed to be held on behalf of that club by that responsible officer,

may be granted subject to such additional terms and conditions (in addition to such terms and conditions referred to in section 27(4)) as the Commissioner thinks fit.

(2) The additional terms and conditions referred to in subsection (1) may include, but are not limited to, terms and conditions for the purpose of—

- (a) regulating the conduct of the shooting club in respect of the possession and use of arms and ammunition by its members;
- (b) operating any range, armoury or other facility owned or under the control or possession of that club in respect of the safe use and handling of those arms and ammunition by its members; and
- (c) ensuring the safety of any person.”.

13. Effect of licence for possession

(1) Section 28(e) is amended by adding “, type” after “class”.

(2) Section 28 is amended by repealing “as is prescribed” and substituting “and containing such particulars as the Commissioner may from time to time specify”.

(4) 第27條現予修訂，加入——

“(6) 以下人士可根據本條申請管有權牌照或根據第32條申請為該牌照續期——

- (a) 保安護衛員；或
- (b) 射擊會的負責人員。”。

12. 加入條文

現加入——

“27A. 有關射擊會的附加條件

(1) 即使第11條另有規定並在不限制根據第27條處長所具有的一般權力下，以下所述的管有權牌照——

- (a) 根據第27條批給身為射擊會的負責人員的持牌人的管有權牌照；及
- (b) 說明是由該負責人員代該會持有的管有權牌照，

可按處長認為適當的附加條款及條件(並且是第27(4)條所提述的條款及條件之外的條款及條件)而批給。

(2) 第(1)款所提述的附加條款及條件可包括但不限於為以下目的而施加的條款及條件——

- (a) 就射擊會的會員管有和使用槍械及彈藥而規管該會的營辦；
- (b) 就該會的會員安全使用和處理該等槍械及彈藥而營辦由該會所擁有、控制或管有的任何射擊場、槍械庫或其他設施；及
- (c) 確保任何人的安全。”。

13. 管有權牌照的效力

(1) 第28(e)條現予修訂，在“類別”之後加入“、類型”。

(2) 第28條現予修訂，廢除“須以”之後的所有字句而代以“處長不時指明的格式擬備，並須載有處長不時指明的詳情。”。

14. Effect of dealer's licence

Section 29 is amended—

- (a) by repealing "prescribed class" and substituting "class, type";
- (b) by repealing "as is prescribed" and substituting "and containing such particulars as the Commissioner may from time to time specify".

15. Renewal of licences

- (1) Section 32 is renumbered as section 32(1).
- (2) Section 32(1) is amended—
 - (a) by repealing "the prescribed form" and substituting "such form and containing such particulars as the Commissioner may from time to time specify";
 - (b) by adding ", conforming with section 28 or 29, as the case may be," after "a licence".
- (3) Section 32 is amended by adding—
 - "(2) A licence renewed under this section may be subject to such terms and conditions as the Commissioner thinks fit, including conditions imposing a limit or restriction on the number, class, type or description of arms, or the quantity, class, type or description of ammunition, or both, the subject of the licence."

16. Applicant or licensee to be notified of decision of Commissioner

- (1) Section 34 is amended by adding after subsection (1)—
 - "(1AA) Every decision of the Commissioner whereby he—
 - (a) refuses to authorize an applicant as an arms instructor under section 12(2);
 - (b) exercises any power under section 12(3);
 - (c) refuses to approve the appointment of an agent or servant under section 12A(2);
 - (d) exercises any power under section 12A(3);
 - (e) refuses to approve an applicant as a range officer under section 46C(1); or
 - (f) exercises any power under section 46C(3),
 shall be notified in writing to the applicant or licensee."
- (2) Section 34(1A) is amended by adding "or (1AA)" after "(1)".

14. 經營人牌照的效力

第29條現予修訂——

- (a) 廢除所有“訂明類別”而均代以“某類別、類型”；
- (b) 廢除“方面須”之後的所有字句而代以“以處長不時指明的格式擬備，並須載有處長不時指明的詳情。”。

15. 牌照的續期

- (1) 第32條現予重訂為第32(1)條。
- (2) 第32(1)條現予修訂——
 - (a) 廢除“訂明表格向其提出”而代以“處長不時指明的格式向其提出並載有處長不時指明的詳情”；
 - (b) 在“繳付後，”加入“並在第28或29條(視屬何情況而定)已于符合的情況下”。
- (3) 第32條現予修訂，加入——
 - "(2) 根據本條續期的牌照可受處長認為適當的條款及條件所規限，包括對屬該牌照的標的之槍械的數目、類別、類型或種類，或對屬該牌照的標的之彈藥的數量、類別、類型或種類，或對兩者，施加限制或約束的條件。”。

16. 申請人或持牌人獲通知處長的決定

- (1) 第34條現予修訂，在第(1)款之後加入——
 - "(1AA) 凡處長決定——
 - (a) 拒絕根據第12(2)條授權申請人為槍械導師；
 - (b) 根據第12(3)條行使任何權力；
 - (c) 拒絕根據第12A(2)條批准代理人或受僱人的委任；
 - (d) 根據第12A(3)條行使任何權力；
 - (e) 拒絕根據第46C(1)條批准申請人為射擊場主任；或
 - (f) 根據第46C(3)條行使任何權力，
 其每一項該等決定均須以書面通知申請人或持牌人。”。
- (2) 第34(1A)條現予修訂，在“(1)”之後加入“或(1AA)”。

17. Appeals

- (1) Section 35(1) is amended by adding—
“(aa) who is aggrieved by a decision of the Commissioner referred to in section 34(1AA); or”.
- (2) Section 35 is amended by adding—
“(3) If an appeal is brought or intended to be brought under section 34(1AA)(b), (d) or (f) the exercise of any powers referred to in those paragraphs shall be suspended until—
(a) the expiry of the period of 28 days specified in subsection (1); or
(b) the appeal is disposed of, withdrawn or abandoned, whichever is the later.”.

18. Commissioner to be notified of transactions, etc.

Section 36(1) is amended by repealing “the prescribed form” and substituting “such form and containing such particulars as the Commissioner may from time to time specify”.

19. Dealers to record particulars of all transactions

- (1) Section 37(1) is amended—
(a) by repealing “the prescribed form” and substituting “such form and containing such particulars as the Commissioner may from time to time specify”;
(b) by repealing “the prescribed particulars” and substituting “such other particulars as the Commissioner may from time to time specify in such circumstances”.
- (2) Section 37(4) is amended by repealing “the prescribed” and substituting “those”.

20. Storage of arms, ammunition and imitation firearms by Commissioner

Section 46(3) is amended by repealing “type” and substituting “class, type or description”.

21. Sections added

The following are added—

17. 上訴

- (1) 第35(1)條現予修訂，加入——
“(aa) 對第34(1AA)條所提述的處長的決定感到受屈；或”。
- (2) 第35條現予修訂，加入——
“(3) 如根據或擬根據第34(1AA)(b)、(d)或(f)條提出上訴，則該等條文所提述的任何權力的行使須予暫緩執行，直至——
(a) 第(1)款所指明的28天期限屆滿為止；或
(b) 該上訴已獲處置、撤銷或放棄為止，
兩者以較遲者為準。”。

18. 處長須獲通知交易等

第36(1)條現予修訂，廢除“以”之後的所有字句而代以“處長不時指明的格式將該項交易通知處長，而通知內須載有處長不時指明的詳情。”。

19. 經營人須記錄一切交易詳情

- (1) 第37(1)條現予修訂——
(a) 廢除“訂明的表格備存交易登記冊”而代以“處長不時指明的格式備存交易登記冊，而登記冊內須載有處長不時指明的詳情”；
(b) 廢除“訂明提供的詳情”而代以“處長在該情況下不時指明的其他詳情”。
- (2) 第37(4)條現予修訂，廢除“訂明”而代以“該等”。

20. 由處長儲存槍械、彈藥及仿製火器

第46(3)條現予修訂，廢除“指明類型”而代以“指明類別、類型或種類”。

21. 加入條文

現加入——

46A. Armouries

The Commissioner may by notice in the Gazette specify any place, premises or other enclosed area as an armoury for the safe storage of—

- (a) arms;
- (b) ammunition;
- (c) arms and ammunition;
- (d) imitation firearms; or
- (e) any class, type or description of arms, ammunition or imitation firearms, as the case may be.

46B. Shooting ranges

The Commissioner may, for the purposes of practice, recreation, sport or competition or for the purposes of testing or proving arms and ammunition by a range officer, by notice in the Gazette specify as a shooting range any place or premises (including an open area or enclosed gallery) designed and constructed or adapted as such for the target shooting of live ammunition by a person who is a member of a shooting club or holds a licence for possession of arms or ammunition.

46C. Range officers

(1) The Commissioner may upon the application of any person approve in writing the applicant as a range officer to conduct and supervise the use of a shooting range for the target shooting of live ammunition, to test or prove arms and ammunition at that shooting range and to supervise all persons using that shooting range or any armoury or other facility used in connection therewith.

(2) The Commissioner may attach such conditions to the written approval (including a condition as to the duration of that approval) as the Commissioner thinks fit.

(3) The Commissioner may at any time withdraw any written approval given by him under subsection (1) to a range officer, or may vary or revoke any condition.”

22. Regulations

(1) Section 52(1)(a) is amended by adding—

“(iia) empowering the Commissioner to determine the suitability of a person proposed by a licensee to be appointed by that licensee as his agent or servant to possess or deal in arms or ammunition, and for that purpose to require that person to undergo such tests and examinations as the Commissioner thinks fit;

46A. 槍械庫

處長可藉憲報公告為以下物品的穩當儲存而指明任何地點、處所或其他圍封範圍為槍械庫——

- (a) 槍械；
- (b) 彈藥；
- (c) 槍械及彈藥；
- (d) 仿製火器；或
- (e) 任何類別、類型或種類的槍械、彈藥或仿製火器，視屬何情況而定。

46B. 射擊場

為了進行練習、康樂活動、運動或比賽或為了讓射擊場主任測試或試驗槍械及彈藥，處長可藉憲報公告，指明任何經設計和建造或改装以供持有槍械或彈藥管有權牌照或身為射擊會的會員的人進行實彈標靶射擊的射擊場的地點或處所(包括露天地方或圍封場館)為射擊場。

46C. 射擊場主任

(1) 處長可在接獲任何人的申請後，以書面批准該申請人為射擊場主任，使其可為實彈標靶射擊而主持和監督射擊場的使用，測試或試驗在該射擊場的槍械及彈藥，以及監督所有使用與該射擊場或相關而使用的任何槍械庫或其他設施的人。

(2) 處長可在書面批准中附有處長認為適當的條件(包括有關該批准書的持續期的條件)。

(3) 處長可在任何時間撤回他根據第(1)款給予射擊場主任的任何書面批准，亦可更改或撤銷任何條件。”

22. 規例

(1) 第52(1)(a)條現予修訂，加入——

“(iia) 賦權處長決定持牌人所建議的人是否適宜由該持牌人委任為其代理人或受僱人以管有或經營槍械或彈藥，並為該目的而規定該人接受處長認為適當的測試及檢驗；

- (iib) empowering the Commissioner to determine the suitability of a person applying to be authorized as an arms instructor, and for that purpose to require the applicant to undergo such tests and examinations as the Commissioner thinks fit;
- (iic) in the case of a licence granted to a licensee who is a responsible officer of a shooting club, empowering the Commissioner to determine the criteria in respect of that club to operate any shooting range, armoury or other facility owned or under the control or possession of that club, including satisfying himself as to the following requirements, namely—
- (A) the satisfactory physical design or layout of the shooting range, armoury or facility;
 - (B) the presence at all relevant times of a range officer to supervise its use;
 - (C) the conditions (commonly known as range orders) to be drawn up and observed in connection with its use; and
 - (D) the necessary safety features to be installed and safety precautions to be observed;
- (iia) empowering the Commissioner to determine the suitability of a person applying to be approved as a range officer, and for that purpose to require the applicant to undergo such tests and examinations as the Commissioner thinks fit;
- (iie) empowering the Commissioner to determine the content and extent of courses to be conducted by arms instructors in the safe use and handling of arms and ammunition;”.
- (2) Section 52(1)(a)(iii) is amended by repealing “or type of arms and ammunition” and substituting “, class, type or description of arms, or the quantity, class, type or description of ammunition, or both,”.
- (3) Section 52(1)(b) and (d) is amended by repealing “prescribing” and substituting “specifying”.
- (4) Section 52(1)(c) is amended by adding “, the determination of matters referred to in subsection (1)(a)(ii), (iia), (iib) and (iid)” after “ammunition”.

23. Section substituted

Section 54 is repealed and the following substituted—

“54. Amendment of Schedules

- (1) The Legislative Council may by resolution amend Schedule 1.
- (2) The Commissioner may by notice in the Gazette amend Schedule 2.”.

- (iib) 賦權處長決定申請獲授權為槍械導師的人是否適宜擔任槍械導師，並為該目的而規定申請人接受處長認為適當的測試及檢驗；
- (iic) 就屬批給身為射擊會的負責人員的持牌人的牌照而言，賦權處長就該會釐定準則，以營辦任何由該會所擁有、控制或管有的射擊場、槍械庫或其他設施，包括令處長本人滿意有關以下事宜的規定，即——
- (A) 射擊場、槍械庫或設施的令人滿意的實物設計或布置；
 - (B) 射擊場主任在任何有關時間均在場監督上述地方的使用；
 - (C) 與上述地方的使用相關而須擬定和遵守的條件(通常稱為射擊場指令)；
- 及
- (D) 須裝設的必要的安全設備以及須遵守的安全預防措施；
- (iia) 賦權處長決定申請獲批准為射擊場主任的人是否適宜擔任射擊場主任，並為該目的規定申請人須接受處長認為適當的測試及檢驗；
- (iie) 賦權處長決定由槍械導師就槍械及彈藥的安全使用和處理所須舉辦的訓練課程的內容及範圍；”。
- (2) 第 52(1)(a)(iii) 條現予修訂，廢除“槍械及彈藥的數目或類型”而代以“槍械的數目、類別、類型或種類，或彈藥的數量、類別、類型或種類，或此兩者”。
 - (3) 第 52(1)(b) 及 (d) 條現予修訂，廢除“訂明”而均代以“指明”。
 - (4) 第 52(1)(c) 條現予修訂，在“彈藥”之後加入“、第(1)(a)(ii)、(iia)、(iib) 及 (iid) 款所提述的事宜的決定”。

23. 取代條文

第 54 條現予廢除，而代以——

“54. 修訂附表

- (1) 立法局可藉決議修訂附表 1。
- (2) 處長可藉憲報公告修訂附表 2。”。

24. Transitional provisions

Section 57 is repealed.

25. Provisions to which sections 17(2) and 20(2) apply

The Schedule is renumbered as Schedule 1.

26. Schedule added

The following is added—

"SCHEDULE 2 [ss. 2(1) & 54]

SHOOTING CLUBS

Item	Name
------	------

Summary Offences Ordinance

27. Interpretation

Section 2(1) of the Summary Offences Ordinance (Cap. 228) is amended by adding—

““air gun” (氣槍) means any gun, rifle or pistol which uses compressed gas or compressed gases as a propellant agent and from which any shot, bullet or missile can be discharged with a muzzle energy not greater than 2 joules;”.

28. Nuisances committed in public places, etc.

Section 4 is amended by adding—

“(14A) knowingly or negligently discharges any air gun in a public place to the danger or annoyance of any person;”.

24. 過渡性條文

第57條現予廢除。

25. 第17(2)及20(2)條適用的條文

附表現予重訂為附表1。

26. 加入附表

現加入——

“附表2

[第2(1)及54條]

射擊會

項

名稱

〈簡易程序治罪條例〉

27. 釋義

《簡易程序治罪條例》(第228章)第2(1)條現予修訂，加入——

““氣槍”(air gun)指使用一種或多於一種受壓縮氣體為推動作用物並可發射任何射彈、子彈或投射物，而槍口能量不超過2焦耳的任何槍、長槍或手槍；”。

28. 在公眾地方犯的妨擾罪等

第4條現予修訂，加入——

“(14A) 在公眾地方明知而發射或疏忽地發射任何氣槍並對任何人構成危險或阻擾；”。

Explanatory Memorandum

The purpose of this Bill is to amend the Firearms and Ammunition Ordinance (Cap. 238) to—

- (a) require that the members of shooting clubs (whose responsible officers hold licences for possession of arms and ammunition on their behalf) also hold such licences, or have completed relevant courses of instruction in the safe use and handling of those arms and ammunition;
- (b) provide for the Commissioner of Police to authorize licensees or their agents or servants to act as arms instructors for the purpose of instructing others in the safe use and handling of arms and ammunition;
- (c) provide for the possession of, or dealing in, arms or ammunition by licensees' agents or servants whose appointments or employment have been approved by the Commissioner of Police;
- (d) provide for additional safeguards for the possession of arms or ammunition by shooting clubs in the interests of public safety;
- (e) provide for the removal of obsolete and inflexibly worded statutory forms and their replacement by new forms specified by the Commissioner of Police;
- (f) provide for decisions of the Commissioner of Police in relation to his new powers to be notified to the persons affected;
- (g) provide for those persons to appeal should they be aggrieved by particular decisions;
- (h) extend regulation-making powers contained in the principal Ordinance in order for the Commissioner of Police to determine the suitability or otherwise of the appointment, authorization or approval of licensees' agents or servants, arms instructors or range officers, and to ensure the safety of shooting ranges and armouries operated or used by shooting clubs;
- (i) provide for the formal specification by the Commissioner of Police of those armouries and shooting ranges;
- (j) add a new Schedule 2 to the principal Ordinance for the purpose of identifying the shooting clubs; and
- (k) add new definitions, make consequential amendments and to make a related amendment to the Summary Offences Ordinance (Cap. 228).

摘要說明

本條例草案旨在修訂《火器及彈藥條例》(第238章), 以——

- (a) 規定射擊會(而該射擊會的負責人員是代表其會而持有槍械及彈藥的管有權牌照的)的成員亦須持有該等牌照或已完成有關該等槍械及彈藥的安全使用和處理的有關訓練課程;
- (b) 就警務處處長授權持牌人或其代理人或受僱人使其可為指導其他人有關安全使用和處理槍械及彈藥而擔任槍械導師, 訂定條文;
- (c) 就持牌人的代理人或受僱人管有槍械或彈藥或經營槍械或彈藥(而該等代理人或受僱人的委任或僱用已獲警務處處長批准), 訂定條文;
- (d) 為確保公眾安全而就射擊會管有槍械或彈藥所需的附加預防措施, 訂定條文;
- (e) 就刪除過時的及帶有缺乏彈性字句的法定表格及由警務處處長指明的新表格取代, 訂定條文;
- (f) 就警務處處長須將其新的權力有關而作出的決定通知受影響的人, 訂定條文;
- (g) 就該等因個別決定而感到受屈的人提出的上訴, 訂定條文;
- (h) 擴大主體條例中載有的訂立規例的權力, 使警務處處長可決定持牌人的代理人或受僱人或槍械導師或射擊場主任的委任、授權或批准是否適當, 並確保由射擊場所營辦的或使用的射擊場及槍械庫的安全;
- (i) 就警務處處長對該等槍械庫及射擊場所訂立的正式規格, 訂定條文;
- (j) 為識別射擊會而在主體條例增訂新附表2; 及
- (k) 增訂新定義, 作出相應修訂和對《簡易程序治罪條例》(第228章)作出有關的修訂。

- | | | |
|--|--|---|
| | <ul style="list-style-type: none">— 諮詢名單— 生產商目錄— 貿易署文件 | |
| | | 2 |
| | | |
| | | |
| | | |

附頁 B

TOTAL 3 PAGES

Ref. (38) in CP LIC CON 17/28/1 Pt. II

<u>Distribution</u>	<u>Fax</u>
1. Joe's Paradise Ltd. (Attn.: Mr. Joseph HO)	2601 5245
2. Director of Urban Services (Attn.: Mr. Mark Taylor)	2739 0066
3. Hong Kong Shooting Club (Attn.: Mr. Cleland D. Rogers)	2613 1260
4. Mr. Gary M. Hayes	2336 7407
5. Props Co., Ltd.	2363 6786
6. The HK Academy for Performing Arts (Attn.: Mr. Philip Soden)	2802 4372
7. The British Forces Pistol Club (Attn.: Mr. Andrew KWOK)	2482 7016
8. Disciplined Services Shooting Association Ltd. (Attn.: Mr. LI Kar-sing)	2526 8869
9. Star TV (Attn.: Ms. Jannie POON)	2621 8000
10. Scout Target Shooting Club (Attn.: Mr. Garson LEE)	2302 1163
11. Hong Kong Rifle Association (Attn.: Mr. Peter A. Rull Sr.)	2744 6687
12. Mr. Peter Dawson	2861 1755
13. Phoenix Gun Club Ltd. (Attn.: Mr. Vince Pinto)	2890 3582
14. RHKP Shooting Club (Attn.: Mr. Charles WONG)	2778 2912
15. Hong Kong Practical Shooting Association (Attn.: Mr. Cleland D. Rogers)	2613 1260
16. Hong Kong Shooters Confederation (Attn.: Mr. Micheal LAI)	2544 4250
17. Mr. Thomas Bovet	2838 6022
18. International (Elite) Divers Training Centre (Attn.: Mr. Ronny CHEUNG)	2397 2434
19. RHKR(V) Shooting Club (Attn.: Major P.A. Rull)	2530 1368
20. Hong Kong Gun Club (Attn.: Mr. Alfred K. C. FUNG)	2402 4744
21. CSD Sports Association Gun Club (Attn.: Mr. AU Siu-hau)	2813 0267

Encl.

皇家香港警察總部的信頭

本署檔號 OUR REF.: (38) in CP LIC CON 17/28/1 Pt. II

電話 TELEPHONE: 2860 2520 (Fax: 2866 2530)

內線 EXTENSION:

TELEX NO.: 65367 HX

15 May 1996

To : Distribution

Dear Sirs,

Discussion on Consultation Paper

You are invited to attend an informal discussion on the review of the Firearms and Ammunition Ordinance to be held at The Reading Room of the Police Officers' Club, Hung Hing Road, Causeway Bay, at 1430 hours on Tuesday 21 May 1996. A copy of the agenda for this discussion is attached.

Parking arrangements are available on the day of this meeting at the Police Officers' Clubs and a fee of HK\$20.00 per hour is payable for this facility.

I look forward to meeting you and to exchange our views at the meeting.

Yours Sincerely,

(AU Hok-lam)
Superintendent Licensing
for Commissioner of Police

...../Distribution

AGENDA FOR DISCUSSION WITH SHOOTING CLUBS

1. Test on applicants for firearms licence
2. Syllabus for the Test
3. Range standard
4. UK Proof House Certificates
5. Intending shooter be permitted access to firearms otherwise he cannot be instructed on the safe handling of firearms
6. “Agent or servant”
7. “Persons transiting HK whilst in possession of arms and ammunition”
8. Air Guns
 - Spring pistons
 - CO2 activated air guns
 - Possession of air soft gun in a public place

附頁 C

LAPUA

SUPERIOR AMMUNITION

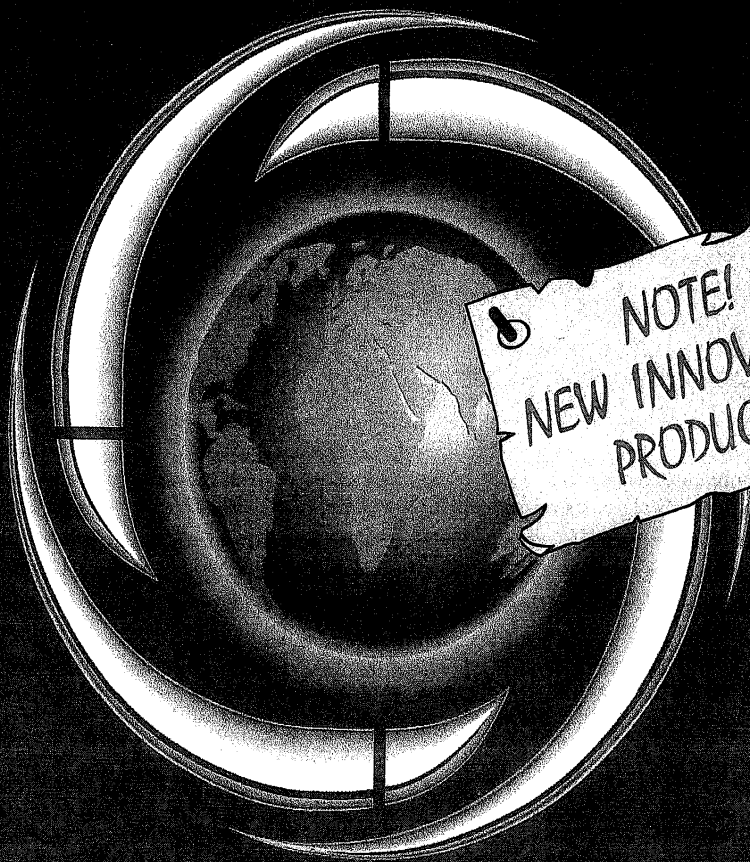

NOTE!
NEW INNOVATIVE
PRODUCTS

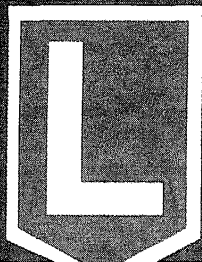

LAPUA

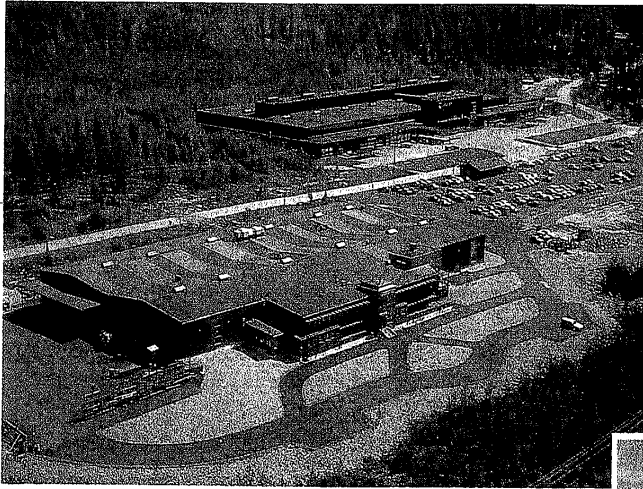

A partial view of Lapua Ltd factory area showing the head office and tool factory (opened in 1994) in the foreground with the component factory (opened in 1984) in the background. Today the oldest sites of the factory are from 1978.

The design of Lapua cartridge boxes has gone through a radical modernisation. The new design symbolises the World famous quality of LAPUA cartridges. Amongst other features, the strictest environment regulations have been taken into consideration (Der Grüne Punkt). The Quality System of Lapua Ltd meets the requirements of ISO 9001 and AQAP-110.

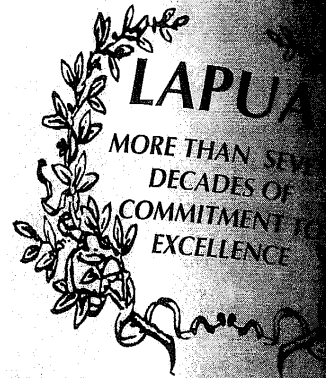

Development amidst tranquillity: in the peaceful scenery of Central Finland product development is given a big boost in one of the most modern ammunition factories that exist: Lapua Ltd. The top quality credentials, for which Lapua is renowned Worldwide, have here the basis they deserve.

Novelty products are designed by experienced top experts in close co-operation with competition shooters and other users. During the many phases of production every product is examined by utilising mechanical, electrical and visual methods. Both the product development department and quality control section are equipped with the best machinery and devices available.

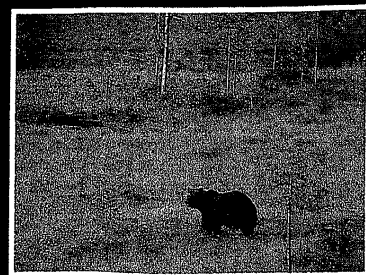
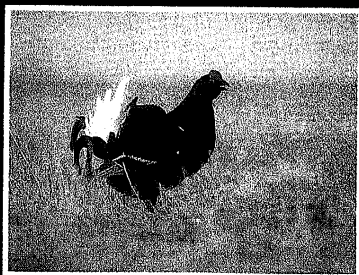



LAPUA rifle cartridges have brought numerous gold medals in World Championships, Olympic Games and in other national and international shooting competitions since 1923!

Rifle Cartridges

Product No.	Calibre	Bullet		Weight		Loading data		Velocity (m/s)							Energy (J)							Trajectory (mm) (scope)		
		Type	Code	N	Gr	Power	Charge	0	25	100	150	200	300	0	25	100	150	200	300	50	100	150	200	
4315020	222 Rem	5.7x43	FMJ	S 382	3.6	55	N 133	1.3	880	847	755	696	640	534	1393	1294	1027	738	514	-2	0	-41	-134	
4315030	222 Rem	5.7x43	SP	E 369	3.6	55	N 133	1.3	860	842	734	666	601	482	1393	1277	970	651	418	-2	0	-45	-145	
4315040	223 Rem	5.56 mm	FMJ	S 350	3.6	55	N 133	1.3	955	920	829	767	710	601	1641	1541	1234	907	659	-2	0	-42	-105	
4315050	223 Rem	5.56 mm	SP	E 372	3.6	55	N 133	1.3	955	914	792	725	666	527	1641	1505	1148	775	541	-2	0	-42	-117	
4316050	243 Win	6.16x51	FMJ	S 342	5.8	90	N 160	2.7	885	864	804	765	727	654	2271	2167	1676	1535	1243	-3	0	-35	-113	
4316054	243 Win	6.16x51	Mega	E 457	6.5	100	N 160	2.6	935	908	824	772	721	624	2841	2672	2110	1690	1581	-5	0	-39	-106	
4316045	6mm BR Rem		Scenar	GB 478	5.8	105			860	839	772	724	670	582	2498	2370	2133	1641	1534	-2	0	-42	-117	
4316033	6.5x55 Swedish		FMJ	S 341	6.5	100	N 135	2.5	830	799	711	655	602	501	2238	2074	1642	1177	815	1	0	-49	-156	
4316031	6.5x55 Swedish		Scenar	GB 464	7.0	108	N 150	2.8	900	844	837	806	776	718	2835	2735	2453	2112	1807	-4	0	-31	-101	
4316030	6.5x55 Swedish		Scenar	GB 458	9.0	139	Rp 5	2.8	800	788	754	780	711	668	2890	2798	2564	2275	2011	0	0	-44	-133	
4316029	6.5x55 Swedish		Scenar	GB 458	9.0	139	Rp 5	3.0	850	838	803	732	758	714	3251	3161	2905	2597	2286	-3	0	-36	-113	
4316021	6.5x55 Swedish		Mega	E 471	10.1	155	Rp 5	2.9	797	777	719	681	645	575	3207	3049	2610	2101	1670	1	0	-49	-151	
4317051	270 Win		Mega	E 438	8.3	130	Rp 5	3.4	900	870	816	778	740	668	3401	3246	2810	2305	1882	4	0	-34	-108	
4317051	270 Win		Mega	E 438	10.4	160	Rp 5	3.8	915	884	822	807	768	695	3453	3255	2774	2297	1858	0	0	-32	-105	
4317055	7x64		Mega	E 426	11.0	170	Rp 5	3.4	793	769	702	659	617	537	3458	3259	2713	2095	1589	2	0	-70	-221	
4317059	7mm Rem Mag		Mega	E 426	11.0	170	Rp 5	3.4	850	825	758	715	675	594	3072	2857	2433	1851	1451	0	0	-42	-135	
4317235	7.62x39		FMJ	S 405	8.0	123	N 125	1.6	715	689	616	570	525	441	2044	1902	1521	1104	780	7	0	-72	-221	
4317237	7.62x39		Mega	E 468	8.1	125	N 125	1.6	715	689	614	567	522	437	2070	1922	1528	1103	773	8	0	-73	-222	
4317527	308 Win	7.62x68	FMJ	S 423	9.0	125	N 140	3.0	860	868	824	782	741	659	3204	3077	2481	1656	1270	-2	0	-37	-121	
4317536	308 Win	7.62x68	Lock Base	D 424	9.0	125	N 135	2.8	850	830	787	750	711	628	3221	2985	2374	1618	1265	-2	0	-37	-118	
4317438	308 Win	7.62x68	Wega	E 462	9.2	127	N 144	3.0	830	826	753	719	679	594	3113	2956	2313	1611	1241	-2	0	-41	-120	
4317415	308 Win	7.62x68	Scenar	GB 422	9.0	125	N 135	2.8	850	815	758	725	685	601	3154	2915	2313	1611	1241	-2	0	-41	-120	
4317180	308 Win	7.62x68	FMJ	D 416	9.0	125	N 135	2.8	780	786	751	695	658	575	3045	2895	2295	1640	1265	-2	0	-40	-119	
4317295	308 Win	7.62x68	Lock Base	D 416	11.0	160	N 140	3.0	850	840	787	748	708	623	3071	2924	2326	1656	1265	-2	0	-40	-119	
4317316	308 Win	7.62x68	Lock Base	D 470	11.0	170	N 140	3.0	860	845	801	772	744	659	3067	2917	2326	1644	1265	-2	0	-40	-119	
4317283	308 Win	7.62x68	Mega	E 416	12.0	185	N 150	3.0	785	742	675	632	591	513	3131	2993	2379	1673	1241	-2	0	-40	-119	
4317214	308 Win	7.62x68	FMJ	D 416	12.0	185	N 150	3.0	790	756	690	648	606	520	3144	2995	2350	1749	1241	-2	0	-40	-119	
4317306	308 Win	7.62x68	Mega	E 415	12.0	185	N 150	3.0	784	748	682	640	600	513	3131	2982	2347	1673	1241	-2	0	-40	-119	
4317523	308 Win	7.62x68	Scenar	GB 420	12.0	185	N 150	3.0	785	740	675	632	591	513	3131	2982	2347	1673	1241	-2	0	-40	-119	
4317320	308 Win	7.62x68	Scenar	GB 420	12.0	185	N 150	3.0	785	740	675	632	591	513	3131	2982	2347	1673	1241	-2	0	-40	-119	
4317315	308 Win	7.62x68	FMJ	D 416	12.0	185	N 150	3.0	790	756	690	648	606	520	3144	2995	2350	1749	1241	-2	0	-40	-119	
4317340	308 Win	7.62x68	FMJ	D 416	12.0	185	N 150	3.0	785	740	675	632	591	513	3131	2982	2347	1673	1241	-2	0	-40	-119	
4317503	7.62x53 R		FMJ	FMJ123	8.0	123	N 150	3.2	895	866	784	738	681	585	3204	3004	2461	1856	1370	-7	0	-34	-115	
4317502	7.62x53 R		Mega	E 415	12.0	185	N 150	3.1	785	742	675	632	591	512	3111	3003	2735	2095	1575	-3	0	-88	-177	
4317604	7.62x53 R		Forex	EX 481	12.0	185	N 150	2.9	790	766	699	656	614	540	3744	3429	2605	1749	1124	4	0	-85	-189	
4317527	308 Win	7.62x68	FMJ	D 416	12.0	185	N 150	3.2	895	868	784	738	681	585	3204	3004	2461	1856	1370	-7	0	-34	-115	
4317563	308 Win	7.62x68	Mega	E 415	12.0	185	N 150	3.1	785	742	675	632	591	512	3111	3003	2735	2095	1575	-3	0	-88	-177	
4317562	308 Win	7.62x68	Forex	EX 481	12.0	185	N 150	2.9	790	766	699	656	614	540	3744	3429	2605	1749	1124	4	0	-85	-189	
4317517	308 Win	7.62x68	Mega	E 415	12.0	185	N 150	3.1	785	742	675	632	591	512	3111	3003	2735	2095	1575	-3	0	-88	-177	
4319074	8x57 JS		SP	E 380	13.0	200	N 140	3.0	750	724	662	605	561	477	3656	3415	2765	2047	1479	5	0	-83	-193	
4319003	338 Lapua Mag		Lock Base	D 424	16.2	250	Rp 5	3.0	687	657	606	565	524	441	3061	2836	2299	1678	1241	-2	0	-36	-119	
4319014	338 Lapua Mag		Forex	EX 482	16.2	250	Rp 5	3.0	687	657	606	565	524	441	3061	2836	2299	1678	1241	-2	0	-36	-119	
4319018	9.3x62		Forex	EX 483	17.5	270	N 135	3.5	725	720	629	593	540	458	4599	4287	3461	2551	1835	-7	0	-69	-210	
4319016	9.3x62		Mega	E 433	18.5	285	N 135	3.5	680	669	609	571	533	463	4403	4144	3438	2637	1987	9	0	-75	-227	

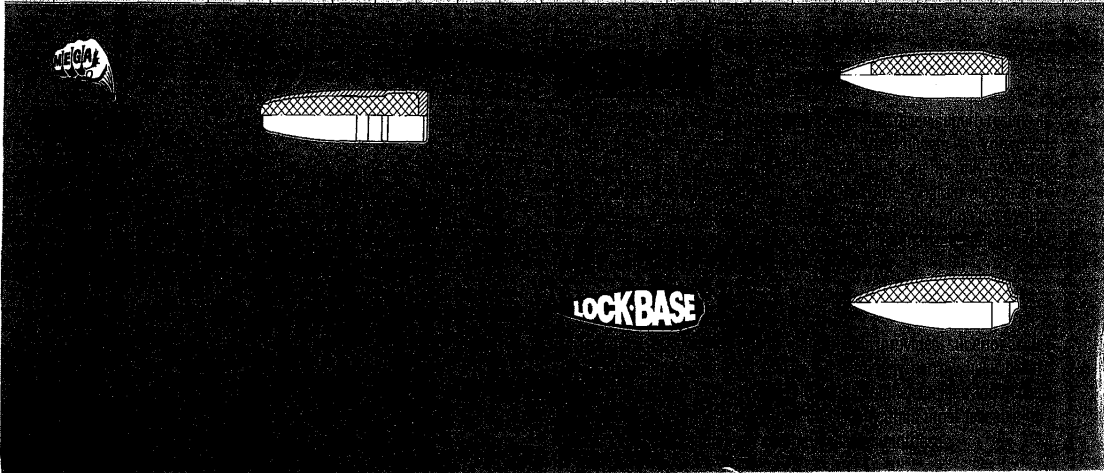

Rimfire cartridges



Product no.	Type	Bullet		Velocity (m/s)				Energy (J)				Trajectory			Crosswind drift (m) wind 4 m/s				Barrel length (mm)
		Weight		m				m				m			m				
		g	gr	0	25	50	100	0	25	50	100	25	50	100	25	50	75	100	
4317021	.22 Long Rifle - Midas M	2.59	40	325	310	297	276	137	125	115	99	21	0	-259	8	30	68	117	650
4317022	.22 Long Rifle - Midas L	2.58	40	325	310	297	276	137	125	115	99	21	0	-259	8	30	68	117	650
4317033	.22 Long Rifle - Master	2.59	40	325	310	297	276	137	125	115	99	21	0	-259	8	30	68	117	650
4317066	.22 Long Rifle - Super Club	2.58	40	320	304	291	268	133	120	110	93	23	0	-269	9	34	74	129	650
4317030	.22 Long Rifle - Scoremax	3.1	48	315	303	292	274	154	142	133	116	23	0	-266	8	25	56	97	650
4317020	.22 Long Rifle - Multi Match	2.59	40	335	318	304	282	145	133	120	103	20	0	-244	9	32	71	122	650
4317031	.22 Long Rifle - Pistol King	2.59	40	315	302	290	270	129	118	109	94	0	-46	-367	8	29	64	113	150
4317050	.22 Long Rifle - Pistol Trainer	2.59	40	315	302	290	270	129	118	109	94	0	-46	-367	8	29	64	113	150
4317023	.22 Long Rifle - Polar Biathlon	2.59	40	335	315	299	273	145	129	116	97	21	0	-255	10	39	85	146	650
4317043	.22 Long Rifle - Speed Ace	2.59	40	410	372	348	324	218	179	152	120	12	0	-187	13	41	112	189	680
4317045	.22 Long Rifle - Hollow Point	2.35	36	410	375	348	310	198	165	142	113	12	0	-181	12	47	102	176	650
4317046	.22 Long Rifle - Subsonic Hp	2.35	36	315	301	288	256	117	106	98	69	24	0	-273	9	32	67	120	500
4312242	.22 Long Rifle - Standard Club	2.59	40	320	304	291	268	133	120	110	93	23	0	-269	9	34	74	129	650
4312249	.22 Short - Rapid Star	2.00	31	220	211	203	187	49	41	35	0	-170	-410	8	41	83	167	100	
4312249	.22 Short - Rapid	1.90	29	280	266	253	230	75	67	61	50	0	-66	-498	10	40	91	161	120

FOR BETTER RESULTS CHOOSE LAPUA!

A new accurate rimfire cartridge **MIDAS** is designed for the best U.I.T. shooters of the world. The new **MIDAS** will replace .22 LR Dominator. New improved production methods and profound development work has made the quality of **MIDAS** even more equal and it will meet the most demanding requirements for accuracy. **Midas** is produced in two different bullet diameters: L = 5,69 mm, M= 5,67mm. M is used in weapons with smaller and L in weapons with larger land and groove dimensions.



A brand new rimfire cartridge for hunting, sports shooting and biathlon: **.22 LR SCOREMAX**. The new cartridge is perfect when used with silencers, muzzle velocity is 315 m/s (Subsonic). Bullet weight is 3,1 g and because of the heavy bullet, it is not sensitive to wind drift. The bullets' accuracy has been tested and the result is amazing: at 50 metres the smallest group diameters (10 shots) are as small as 7,0 mm.



Lapua .22 LR ammunition stands for quality in the world of shooting. Now the Lapua program also includes a reasonably priced alternative: **.22 LR Standard Club**. It is packed in cans of 500 rounds in one unit.





Rifle bullets

Vapori (mm)	Diameter 200 m								Diameter (mm)	
	Diameter									
	300	310	320	330	340	350	360	370		
-511	31	66	59	0	-310	36	84	156	385	590
-566	35	72	64	0	-349	43	101	190	478	580
-405	21	5	17	0	-238	20	70	135	327	500
-485	29	56	53	0	-253	30	82	172	434	560
-412	25	56	49	0	-243	22	50	92	220	640
-402	22	52	47	0	-243	27	64	118	296	640
-414	29	58	49	0	-248	18	51	69	63	
-586	40	78	68	0	-352	38	90	167	413	680
-364	21	50	44	0	-214	16	37	67	158	740
-460	33	66	56	0	-281	14	33	60	140	740
-396	26	56	49	0	-228	13	30	55	128	740
-539	39	75	64	0	-313	26	61	111	266	620
-485	29	56	47	0	-234	21	50	90	216	620
-581	80	69	0	-340	31	73	134	324	600	
-458										
-802	63	110	93	0	-471	42	100	186	456	415
-809	69	111	94	0	-475	43	102	190	467	420
-405										
-412										
-316										
-330										
-404										
-387										
-320										
-344										
-353										
-346										
-404										
-354										
-331	14	42	39	0	-204	25	58	108	260	660
-638	47	88	75	0	-372	33	79	144	347	680
-720	53	95	82	0	-436	47	113	211	531	690
-431										
-570	44	79	67	0	-311	16	37	69	164	690
-666	48	84	72	0	-320	45	107	200	512	740
-501	44	83	72	0	-299	16	37	69	164	740
-701	53	96	82	0	-412	38	90	166	405	610
-345										
-474										
-760	59	105	88	0	-445	40	94	174	427	610
-500	65	113	94	0	-461	37	85	158	382	610

Product	Caliber	Grain	Velocity (m/s)	Weight (g)	Ballistic	Coef. Ballistic	Coef. Drag	Coef. Drag
4PL5003	223 5.56 mm	3.6	85	S350	FMJ	5.7	0.224	0.251
4PL5004	223 5.56 mm	3.6	85	E372	SP	5.7	0.224	0.202
4PL5005	223 5.56 mm	3.6	85	E350	SP	5.7	0.224	0.208
4PL5006	223 5.56 mm	3.6	85	S350	FMJ	5.7	0.224	0.235
4PL6004	243 6.16 mm	5.8	90	S342	FMJ	6.18	0.243	0.385
4PL6007	243 6.16 mm	6.5	100	E457	Mega	6.18	0.243	0.287
4PL6005	243 6.16 mm	6.5	100	S342	FMJ	6.18	0.243	0.350
4PL6014	6.5 mm	8.5	100	S341	FMJ	6.72	0.285	0.250
4PL6020	6.5 mm	7.0	108	GB484	Scener	6.72	0.285	0.502
4PL6018	6.5 mm	8.0	139	GB458	Scener	6.72	0.285	0.660
4PL6010	6.5 mm	10.1	155	E471	Mega	6.7	0.284	0.377
4PL7007	7.0 mm	11.0	170	B442	Lock Base	7.24	0.285	0.470
4PL7075	7.0 mm	11.0	170	E426	Mega	7.23	0.285	0.322
4PL7024	7.0 mm	11.0	170	B442	Lock Base	7.23	0.285	0.470
4PL7025	7.0 mm	11.0	170	B442	Lock Base	7.23	0.285	0.470
4PL7010	7.0 mm	11.0	170	S374	FMJ	6.63	0.305	0.290
4PL7046	7.0 mm	11.0	170	S316	FMJ	6.91	0.311	0.280
4PL7063	7.0 mm	11.0	170	F458	Mega	6.90	0.311	0.272
4PL7013	7.0 mm	11.0	170	G477	Mega	6.88	0.308	0.244
4PL7061	7.0 mm	11.0	170	E426	Mega	6.88	0.308	0.284
4PL7059	7.0 mm	11.0	170	E426	Mega	6.88	0.308	0.284
4PL7062	7.0 mm	11.0	170	E426	Mega	6.88	0.308	0.284
4PL7023	7.0 mm	11.0	170	D478	FMJ	6.88	0.308	0.304
4PL7028	7.0 mm	11.0	170	B442	Lock Base	6.88	0.308	0.292
4PL7027	7.0 mm	11.0	170	B442	Lock Base	6.88	0.308	0.292
4PL7026	7.0 mm	11.0	170	B442	Lock Base	6.88	0.308	0.292
4PL7021	7.0 mm	11.0	170	S374	FMJ	6.88	0.308	0.292
4PL7016	7.0 mm	11.0	170	S374	FMJ	6.88	0.308	0.292
4PL7017	7.0 mm	11.0	170	S374	FMJ	6.88	0.308	0.292
4PL7018	7.0 mm	11.0	170	S374	FMJ	6.88	0.308	0.292
4PL7019	7.0 mm	11.0	170	S374	FMJ	6.88	0.308	0.292
4PL8003	8.2 mm	13.0	200	E380	SP	8.21	0.323	0.289
4PL5014	5.56 mm	3.6	85	B450	Lock Base	6.21	0.333	0.266
4PL6019	9.9 mm	17.5	270	EX483	Forex	9.8	0.368	0.290
4PL6017	9.9 mm	18.5	285	E433	Mega	9.3	0.368	0.338

About 80% of all participants of the Super Shoot 1995 used Lapua cases because of the multiple reloading ability together with supreme precision features.

Product	Caliber	Weight (g)	Ballistic	Coef. Ballistic	Coef. Drag	Coef. Drag
4PH5013	220 Russian		Boxer			
4PH5009	223 Rem	5.9645	Boxer			
4PH4045	6 mm BR Rem		Boxer			
4PH7028	370 Win		Boxer			
4PH7080	7 mm Rem Mag		Boxer			
4PH7045	308 Win	7.6251	Boxer			
4PH7066	30-06	7.6263	Boxer			
4PH8070	338 Win Mag		Boxer			





Pistol and revolver cartridges

LRN = Lead Roundnose
 LWC = Lead Wadcutter
 LSWC = Lead Semiwadcutter
 SJFN = Semi-Jacketed Flat Nose
 SJHP = Semi-Jacketed Hollow Point
 CEPP = Controlled Effect Police Projectile

Product No.	Calibre	Bullet		Weight		Loading data		Velocity (m/s)				Energy (J)				Trajectory			Crosswind drift in mm, wind 4 m/s			Barrel length (mm)	
		Type	Code	g	gr	Powder	Charge	0	25	50	100	0	25	50	100	0	50	100	25	50	75		100
		m																					
4317010	7.65 Browning	FMJ	R 429	4.80	75	N310	0.12	260	252	244	230	162	152	143	127	-20	-77	-545	6	26	57	103	75
4319170	9.0 Br Short	FMJ	Br Short	6.70	95	N310	0.19	285	275	268	252	249	232	219	194	-20	-71	-443	6	23	53	94	80
4319162	9 mm Luger Practical	FMJ		7.45	115		0.38	400	366	340	304	596	498	430	344	-20	-26	-242	11	45	99	170	150
4319200	9 mm Luger	FMJ	R 462	7.50	116	N331	0.39	405	370	343	306	615	513	441	352	-20	-25	-236	11	46	100	171	200
4319175	9 mm Luger CEPP SUPER	FMJ	F 447	7.80	120	NC1292	0.46	360	337	319	292	506	443	397	333	-20	-34	-288	10	38	81	139	108
4319174	9 mm Luger CEPP EXTRA	FMJ	F 447	7.80	120	NC1292	0.46	360	337	319	292	506	443	397	333	-20	-34	-288	10	38	81	139	108
4319181	9 mm Luger Megashock	HP	G 475	8.00	123	N331	0.38	355	332	314	288	505	442	395	331	-20	-35	-298	10	38	82	141	108
4319177	9 mm Luger	FMJ	R 381	8.00	123	N330	0.37	320	306	294	274	410	375	346	299	-20	-45	-353	8	30	65	114	105
4319230	9 mm Luger	FMJ	R 381	8.00	123	PRB	0.40	400	370	346	312	640	546	478	389	-20	-25	-234	10	42	92	158	200
4319163	9 mm Luger Combat	FMJ	R 381	8.00	123	N331	0.38	355	334	318	292	504	447	404	342	-20	-35	-291	9	36	77	134	125
4319025	.32 S&W Long	LWC	C 457	6.35	83	N310	0.19	240	210	194	141	154	116	91	65	-20	-40	-305	30	18	37	64	100
4319022	.32 S&W Long	LWC	C 358	6.35	86	N310	0.11	240	219	193	165	183	152	126	67	-20	-69	-424	31	16	36	60	100
4319056	.32 S&W Long	LWC	C 358	6.35	86	N310	0.15	250	210	201	214	195	184	170	145	-20	-36	-272	9	34	76	136	150
4319180	.38 Special Megashock	HP	G 475	8.00	123	N331	0.38	355	332	314	288	504	442	395	331	-20	-35	-298	10	38	82	141	100
4319025	.38 Special	LWC	C 355	9.60	148	N310	0.18	230	215	201	176	254	222	194	148	-20	-113	-811	16	22	148	257	150
4319138	.38 Special CEPP EXTRA	FMJ	F 465	9.70	150	N331	0.49	300	290	281	265	437	409	384	341	-20	-53	-394	5	22	50	88	150
4319140	.38 Special	SP	E 367	10.20	158	N331	0.43	315	305	296	280	506	474	446	400	-20	-47	-352	5	64	47	82	
4319143	.38 Special LF	FMJ	F 463	10.20	158	N331	0.40	255	249	242	231	332	315	300	272	-20	-80	-554	5	21	46	85	
4319137	.38 Special	LRN	C 394	10.30	158	N310	0.25	255	249	242	231	335	318	303	275	-20	-60	-554	5	21	46	85	150
4319213	.357 Mag CEPP SUPER	FMJ	F 454	9.70	150	N331	0.60	370	343	332	307	694	661	536	466	-20	-30	-282	7	32	70	119	100
4319212	.357 Mag	SJFN	E 397	10.20	158	N310	0.62	470	440	413	364	1127	980	869	685	-20	-11	-107	7	31	50	85	210
4319216	.357 Mag	SJHP	EG 311	10.20	158	N310	0.62	470	450	449	364	1127	981	855	685	-20	-11	-107	7	31	50	85	210
4319215	.357 Mag	SWC	C 364	10.30	158	N310	0.35	354	338	314	289	531	464	397	320	-20	-30	-270	5	30	65	113	150
4319236	.44 Mag	SJHP	EG 472	15.60	240	N310	1.54	465	430	399	349	1687	1444	1240	951	-20	-13	-161	9	37	83	149	275

Handgun bullets

LAPUA stands for ultimate quality!

Product No.	Calibre	Weight	Type	Code	LWC	Ballistics		
						BC	FL	DR
4PL6003	6.35 mm	3.25	50	Browning	FMJ	0.57	0.251	0.123
4PL6004	6.35 mm	4.30	50	Browning	FMJ	0.54	0.305	0.215
4PL6015	7.65 mm	4.80	50	Br	FMJ	0.58	0.360	0.160
4PL6005	.32 S&W	5.35	83	C 427	LWC	7.96	0.319	0.029
4PL6002	.32 S&W	6.35	98	C 366	LRN	7.96	0.313	0.041
4PL6001	.32 S&W	6.35	98	C 359	LWC	7.96	0.315	0.100
4PL6006	9 mm Luger	6.70	95	Br Short	FMJ	8.58	0.354	0.191
4PL6016	9 mm Luger	7.50	116	Parabellum	FMJ	9.62	0.345	0.110
4PL6007	9 mm Luger	7.80	120	F 447	CEPP Super	9.62	0.345	0.119
4PL6010	9 mm Luger	7.80	120	F 447	CEPP Extra	9.62	0.353	0.118
4PL6022	9 mm Luger	8.00	123	G 475	Megashock	9.62	0.365	0.112
4PL6016	9 mm Luger	8.00	123	R 381	FMJ	9.62	0.355	0.125
4PL6012	9 mm Luger	9.70	150	F 454	CEPP Extra LF	9.62	0.355	0.147
4PL6023	.38 Spl	8.00	123	C 475	Megashock	9.06	0.357	0.112
4PL6000	.38 Spl	9.60	148	C 355	LWC	9.10	0.358	0.057
4PL6005	.38 Spl	9.70	150	F 454	CEPP Extra	9.06	0.357	0.147
4PL6048	.38 Spl	10.20	158	F 463	FMJ LF	9.06	0.357	0.157
4PL6036	.38 Spl	10.30	158	C 394	LRN	9.16	0.361	0.158
4PL6039	.357 Mag	10.20	158	E 367	SJFN	9.07	0.357	0.166
4PL6040	.357 Mag	10.20	158	EG 310	SJHP	9.07	0.357	0.156
4PL6008	.357 Mag	10.30	158	C 344	SWC	9.12	0.359	0.172



Lapua center fire pistol cartridges have gained a reputation amongst the best pistol shooters of the World: about 70 % of the national pistol teams shoot confidently with Lapua center fire cartridges at World championship level!

Latest developments in this section are the CEPP Super, CEPP Extra and the MEGASHOCK for which additional information is available in a separate brochure.

Lapua product line includes a large variety of pistol and revolver bullets for self-loaders. Lapua cases are made of the best raw materials by using the latest know-how and technology. For better results choose Lapua components!

Pistol and revolver cases

Product No.	PISTOL AND REVOLVER CASES		Primer Pops
4PH7040	7.65 mm Browning	.32 Auto	Berdan
4PH7051	7.65 mm Parabellum	.30 Luger	Berdan
4PH9014	9 mm Br Short	.380 ACP	Boxer
4PH9030	9 mm Luger	9 mm Parabellum	Boxer
4PH9019	9 mm Luger	9 mm Parabellum	Berdan
4PH9014	.32 S&W Long		Boxer
4PH9011	.38 S&W		Boxer
4PH9008	.38 Special		Boxer
4PH9015	.357 Magnum		Boxer



Shotgun cartridges

HUNTING CARTRIDGES					
Product no.	Cartridge	Shot load g	Shot size		Packing
			no.	mm	
4331110	1276 Blue Magnum	46	1	4.00	10/500
4331130	1276 Blue Magnum	46	3	3.00	10/500
4331150	1276 Blue Magnum	46	5	2.50	10/500
4331310	1270 Yellow Flash	36	1	4.00	10/500
4331320	1270 Yellow Flash	36	2	3.70	10/500
4331340	1270 Yellow Flash	36	4	3.30	10/500
4331510	1270 Green Hunter	36	1	4.00	10/500
4331530	1270 Green Hunter	36	3	3.50	10/500
4331550	1270 Green Hunter	36	5	3.00	10/500
4331588	1270 Green Hunter	36	BB	4.50	10/500
4331710	1270 Black Spine	36	1	4.00	25/250
4331730	1270 Black Spine	36	3	3.50	25/250
4331750	1270 Black Spine	36	5	3.00	25/250

SKEET AND TRAP			
Cartridge	Shot load (g)	Shot size	Packing
1270 Skeet Action	24	9	25/250
1270 Trap Expert	24	7.5	25/250

Air pellets

Product no.	Calibre	Pellet diameter	Pellet type	Packing
43L7200	4.50		Rifle Champion	200
43L7201	4.50	4.49	Rifle Champion	200
43L7202	4.50	4.51	Rifle Champion	200
43L7210	4.50		Rifle Champion Pellet	500
43L7211	4.50	4.49	Rifle Champion Pellet	500
43L7212	4.50	4.51	Rifle Champion Pellet	500
43L7220	4.50		Pistol Champion	200
43L7221	4.50	4.49	Pistol Champion	200
43L7230	4.50		Pistol Champion Pellet	500
43L7231	4.50	4.49	Pistol Champion Pellet	500
43L7240	4.50		Marksman	500
43L7241	4.50	4.49	Marksman	500
43L7242	4.50	4.51	Marksman	500
43L7250	4.50		Marksman Field	500
43L7251	4.50	4.49	Marksman Field	500
43L7260	4.50		Sportsman R (R-rifled)	500
43L7270	4.50		Sportsman S (S-smooth)	500
43L7280	4.50		Arrow Tip	500
43L7285	4.50		Arrow Tip	500
43L7300	4.50		Air Silhouette	500

Blank cartridges

BLANK CARTRIDGES		
	Calibre	Packing
22 Lang Platz	.22	100/10 000
Flobert-Platzpatrone 6 mm	6 mm	100/10 000
Knallpatrone (Black)	9 mm	50/1750
Knallpatrone (N/A)	9 mm	50/1750
8 mm Platzpatrone	8 mm	25/1750

Wax torches

Product no.		Packing
4374002	3 torches/packing, white/blue, length 30 cm	20 packings
4374001	3 torches/packing, 3 different colors, length 30 cm	20 packings



Lapua Reloading Manual contains reloading data for all Lapua bullets in 36 rifle calibres and in 12 handgun calibres. Useful information of internal and external ballistics as well as of the manufacture of bullets and cases is also included in the Lapua Reloading Manual.

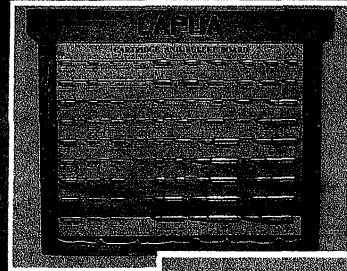

Lapua Ltd also makes available cartridge and bullet display boards as well as accessories with the Company logo.

LAPUA is abound with titles and medals galore in all UIT disciplines, the only ammunition manufacturing company that can so claim.

Most recently Lapua cartridges were winning at the European Championships in Boden (300m), Lahti (running target, trap and skeet) and Zurich (rifle and pistol). Lapua ammunition still holds amongst others, the official World records in the two utmost precision demanding disciplines:

- FREE RIFLE 60 shots prone 50 m, with the outstanding result of 703,5 with .22 LR Dominator.
- FREE RIFLE 60 shots prone 300 m, with the unbeatable result of 600 points out of 600 possible with .308 / 185 gr SCEVAR.

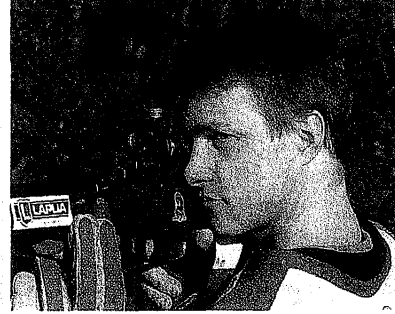

But Lapua is also most visibly present at non-UIT competitions like hunting sport shooting, silhouette, IPSC, benchrest...etc. 13 out of the top 20 shooters used Lapua .220 Russian cases at last year's benchrest World championships, where precision of components is of utmost importance.

Lapua accuracy in combination with specific characteristics for different purposes have made Lapua ammunition very popular world wide amongst reputable hunters as well as the Special Forces of many a powerful country.

Terve tulle for super-kulene!
Vaino Vuori Haukil Stearns

MP-153	MP-152	MP-151	SIS-MSCIP	57	2001
			NR	VAL	100
<p>OFFICIAL RESULTS</p>			TOTAL	600	
<p>DATE: 15.09.99</p>					

Original score protocol of the fantastic world record.



The Quality System of
Lapua Ltd.
meets the requirements
of ISO 9001 and
AQAP-110



LAPUA

Lapua Ltd., P.O.Box 5, FIN-62101 LAPUA, FINLAND

Tel. +358-64-431 0111 (New phone number from 12.10.1996 on +358-6-431 0111)

Fax. +358-64-438 8991 (New fax number from 12.10.1996 on +358-6-438 8991)

附頁 D

Letterhead of Hong Kong Government Trade Department
香港政府貿易署的信頭

Tel : 398 5582

Fax : 789 2491

Props Co Ltd
Unit 7 Lower G/F
Full Wing Bldg
436-450 Chatham Road North
Hung Hom
Kowloon

August 6, 1992

Dear Sir,

9mm BLANK CARTRIDGES

I refer to your licence application receipt no. 830215.

I am pleased to inform you that according to the 1991 Schedule to the Import and Export (Strategic Commodities) Regulations, ammunitions, crimped without a projectile (blank star), are “Non-Strategic”.

Therefore, if your 9mm blank cartridges for movie filming satisfy the above conditions they would be “Non-Strategic” and not subject to import/export control.

Yours faithfully,

C. C. Leung
for Director-General of Trade

- 美國荷李活製作指引
- 軍火專家改裝指引

附頁 E



The Government of the
Hong Kong Special Administrative Region
Television and Entertainment Licensing Authority

MAK Wah-hung, Daniel
Chief Executive Officer
(Film Services)

9/F., Revenue Tower,
5 Clarendon Road,
Hong Kong.
Email : telasec@navigator.com

Tel. : 2594 5741
Fax : 2824 0595
Mobile : 9316 6395

MOVIE INDUSTRY FIREARMS



SAFETY

MOVIE INDUSTRY FIREARMS SAFETY

This industry guideline is intended to be utilized by property department persons, actor/stunt players and others using blank fire adapted weapons.

Distributed to:

B.A.T.F. - Los Angeles office
California State Fire Marshal's Office - Sacramento, CA
D.O.J. - Sacramento, CA Automated Fire Arms Division
I.A. Local #44 - Los Angeles, CA
I.A. Local #891 - Vancouver, B.C. CANADA
Los Angeles County Fire Dept. - Film Unit
Los Angeles County Fire Dept. - Public Relations
S.A.G.

This material is in no way an endorsement by any of the above entities.

The following pages are only recommendations.

By Jefferson Wagner ©1994

This pamphlet will suggest basic operating guidelines for "firearms on the set." I am sure that there are some "good old boys" out there who will read the next few passages and find faults. If, at times, my attitude appears curt or brash, it is because I am not a politician. I put this pamphlet together simply to try to prevent unnecessary injuries.

Every production you work on will be different in terms of the personnel, cast & crew, location, weather, etc. The caliber of the firearms will differ as well as the blank ammunition operating them. Keeping these factors in mind, let's practice *practical safety*. *Practical safety, together with common sense*, must be the true director on the set. Your coworkers will be grateful when you show *command presence* while making safety decisions.

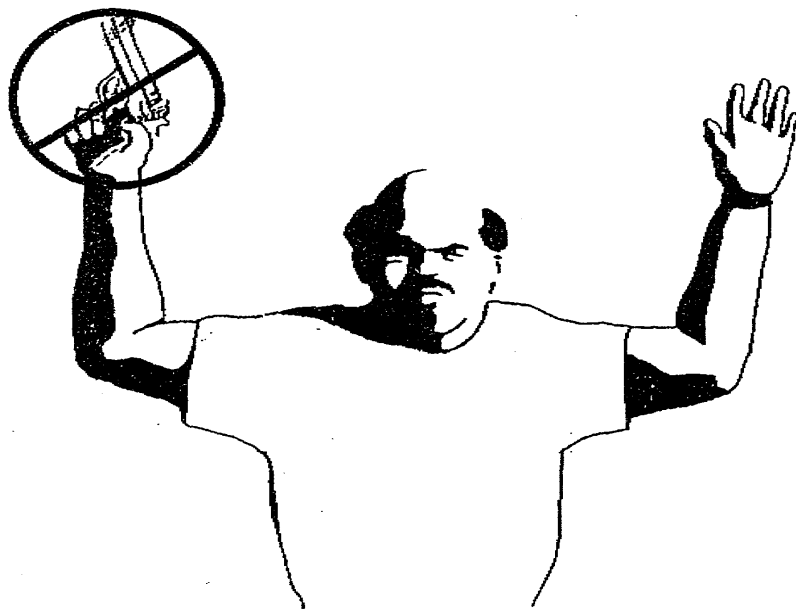

“The Old Way”

PROCEDURE

In the past, some operators and prop persons have instructed actors to raise the weapon above their heads after they hear, “Cut” (see page 2). There are several good reasons that this practice *should* change.

There could be a malfunction of the weapon and a late discharge, or the actor/stunt player might accidentally discharge another blank while in the raised up position. The probability of injury to the actor/stunt player is greater, because:

1. The gas release is close to your eyes and ears.
2. The gas release may be close to another cast or crew member’s head and face.
3. Brass casings ejected from semi-auto pistols, assault weapons and machine guns can strike actors/stunt players about the head and face, or go down a shirt or blouse.
4. While raising and lowering the weapon, it inadvertently gets aimed at the weapon handler, who may be approaching.
5. Often, when an actor/stunt player aims away from the handler for safety, he may now be directing it toward another person to his or her side.
6. The “lowered” position (see page 4) is a more relaxed position for the actor/stunt player. Fewer muscle groups are used than in the raised position. If there is a discharge, it will now be directed at the ground and if brass is ejected there is less chance it will strike someone.

"The Proper Way"

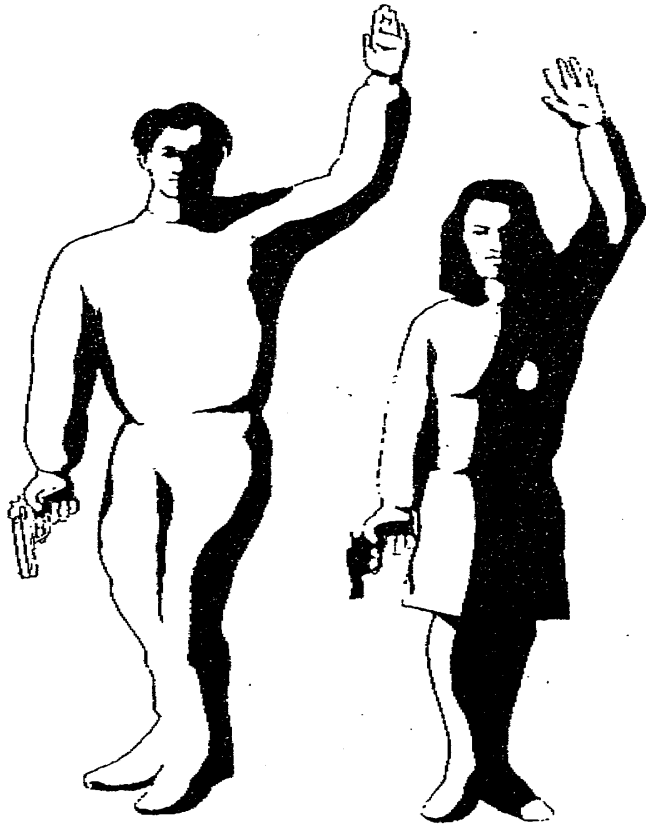

PROP MASTER/WEAPONS HANDLER

Basic rules while operating firearms on the set:

1. Consider discharge zones. Do **NOT** point near crew members or cast. (See page 15)
2. Consider a firearm **ALWAYS** loaded until **YOU** unload it after retrieving it from the actor/stunt player.
3. Do **NOT** depend on firearm safety mechanisms. Revolvers and some semi-auto pistols don't have them; Glocks safety mechanisms are actually in the trigger!
4. Check that internally threaded or externally mounted barrel restrictors are fitted properly and that the flash suppressor itself is firmly secured and not cracked.
5. Make sure everyone in the vicinity is wearing ear protection. People on camera can wear "foamies." **ALWAYS** offer ear protection.
6. Carry firearms to action positions **UNLOADED**. (See pages 6, 7, & 8)
7. Look the actor in the eye and notify him or her that the weapon is **"HOT"** and ready to fire when the trigger is pulled. Ask them to leave their trigger finger in "ready position" until discharge. (See page 6)
8. In a loud voice, notify crew that weapon is **"HOT."**
9. Instruct the actor/ stunt player that in the event of a malfunction or jam, to raise his/her hand and then lower the weapon away from the face. (See page 4)

SAFE CARRY REVOLVER



READY POSITION

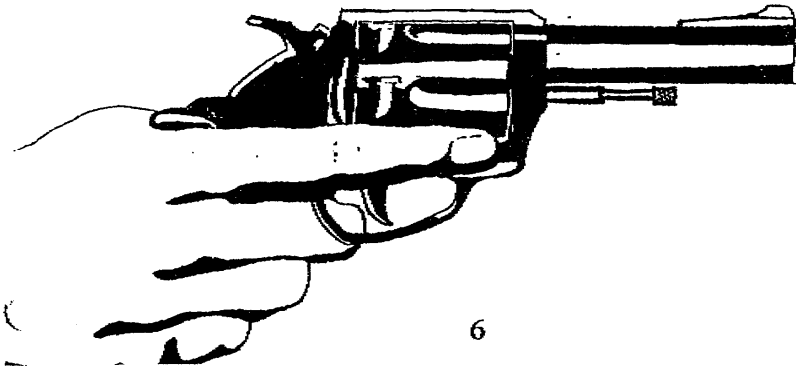

6

SAFE CARRY PISTOL

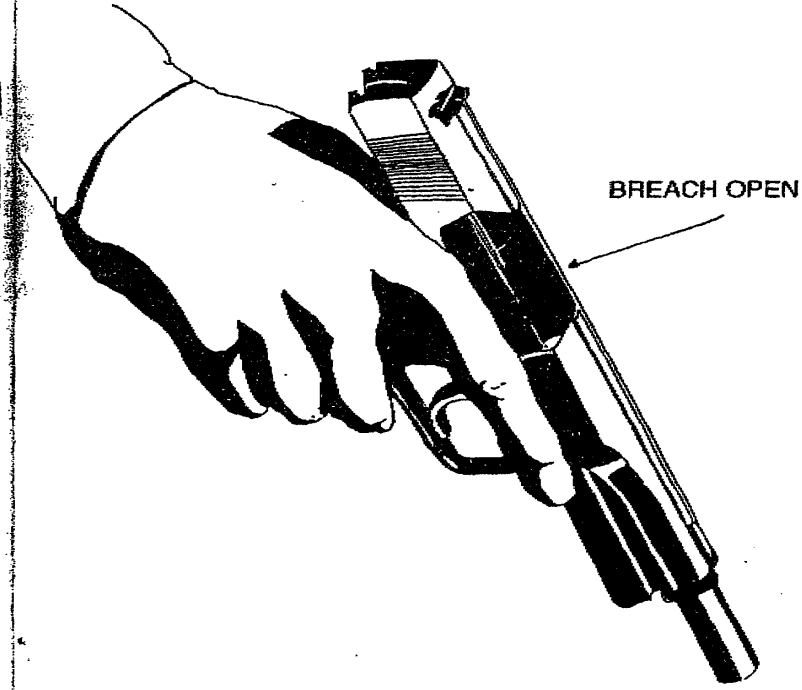

6-NOV-98 FRI 15:26

G3

P.06

DE-NMJI-1000 15:30

P.07

SAFE CARRY RIFLE/SHOTGUNS

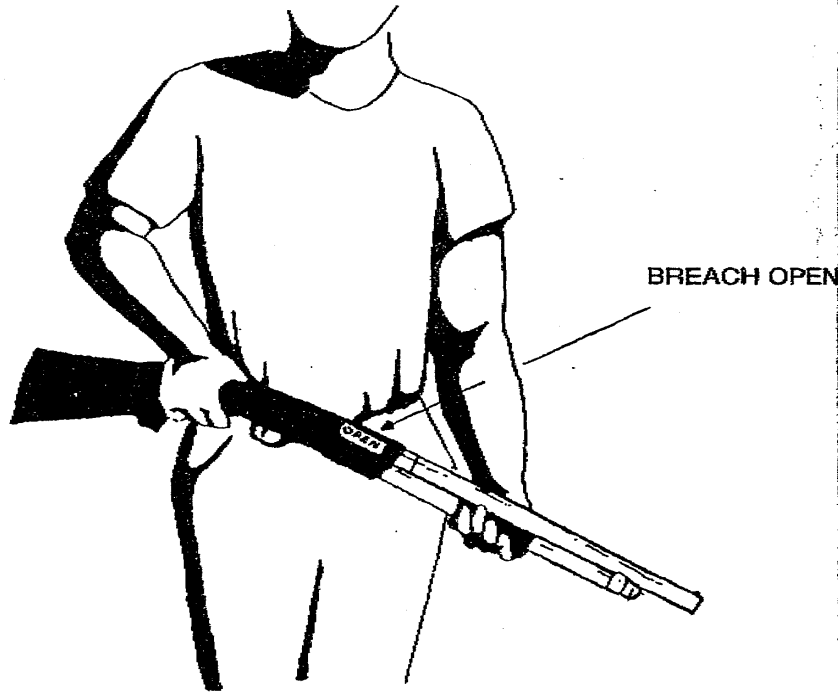

BREACH OPEN

REPLICA WEAPONS

Quite often production calls for the cast and crew, stunt players or extras to carry replica firearms. On almost every set I have worked, these props have been treated with complete disregard. This shows a very unprofessional attitude.

The working replica gun's value has increased in the past several years due to the new state and federal importation laws. (Most replica guns are imported.) Replica firearms should be treated with the same respect as operating firearms. Actors/stunt players should **NOT** "dry" fire or operate charging mechanisms until told to do so by a production authority.

RUBBER WEAPONS

Rubber weapons, which cost between \$150 and \$300 apiece in 1995, were designed to be carried by stunt persons during falls and fight scenes. Most rubber guns look like the real thing. Treat them with the same respect you would a real firearm. Sure, it's fun to "fast draw" these props or point them at your buddy, but think of how others around you view this activity. The image you portray on the set is the image others rely on when considering you for possible future work.

BLANK AMMUNITION

Centerfire

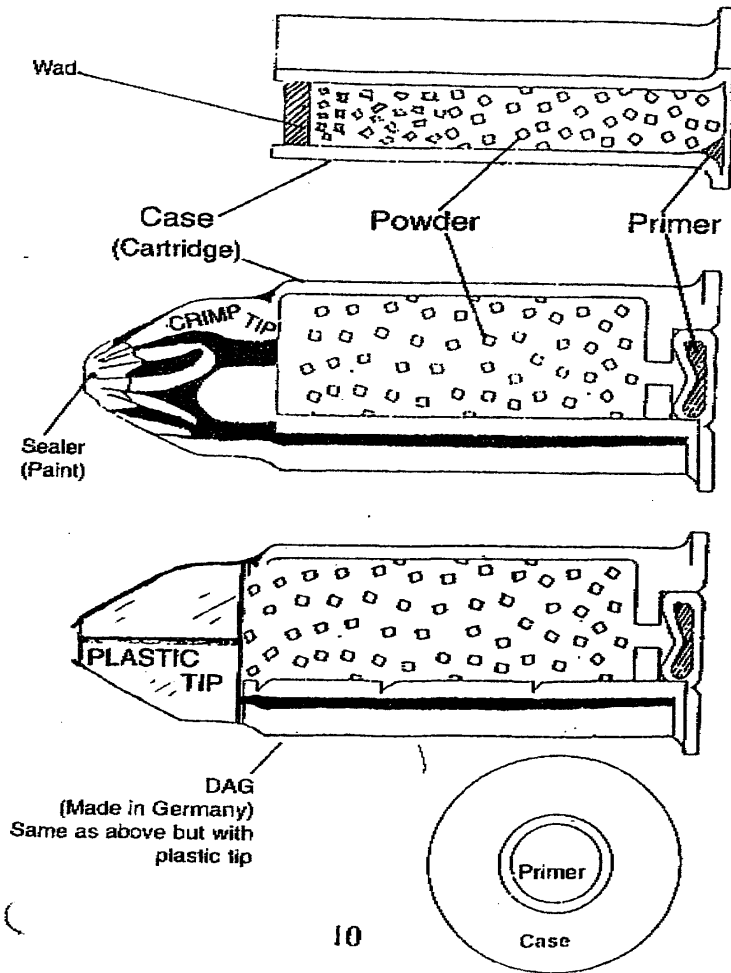

10

WHAT ACTUALLY OCCURS WHEN A WEAPON IS FIRED.

- BLANK DISCHARGE -

1. The trigger is depressed and the hammer is released to strike a firing pin.
2. The pin moves with enough velocity forward into the cylinder of a revolver, breach of a pistol, shotgun, or the receiver of a machine gun or assault weapon.
3. The pin strikes the rear of the blank charge.
4. The primer ignites the powder inside the cartridge and burning begins.
5. As a gas generated inside the cartridge expands, as part of the burn it forces out wadding in revolver and shotgun blanks. It forces open the crimp of semi-auto pistols and assault weapon blanks.
6. This gas continues burning and expanding as it enters the barrel. In some semi-automatic and full automatic weapons, some gas is diverted to recycle the bolt and discharge the expended blank. In other semi-automatic and automatic weapons, a restrictor is machined in the barrel to restrict gas back to operate the bolt and extraction process. In revolvers, pump action shotguns, breach or receiver fed shotguns, and bolt action rifles, all the gas leaves the end of the barrel with paper or cardboard wadding, and other particles.

11

How Far Away Is Safe?

As described on page 11, the release of burning gas, blank wadding materials and brass particles from the crimp are elements of possible injury. There are so many variations of firearms and combinations of blanks used that we would need volumes to describe all the possibilities. Common sense must be used. Some of the blank ammunition boxes have disclaimers that state, "unsafe within 20 feet." This is the manufacturer's "safe" distance. Often the action being filmed calls for shots to be fired within 5 to 10 feet of another actor/stunt player.

A safe check procedure or test fire display could demonstrate a safe distance for a discharge. Set up a "C" stand with an arm out and hang a piece of tissue paper from it. Stand back at the distance the director wants and discharge the weapon. Upon firing, if the tissue paper is shattered apart, step back a few feet. Finally, of course, you will "cheat" the weapon by actually firing the weapon away from the other actor/stunt player. (See page 15)

NEVER, under any circumstances, aim or shoot toward the head and face of another person. The weapon should **ALWAYS** be "cheated" away.

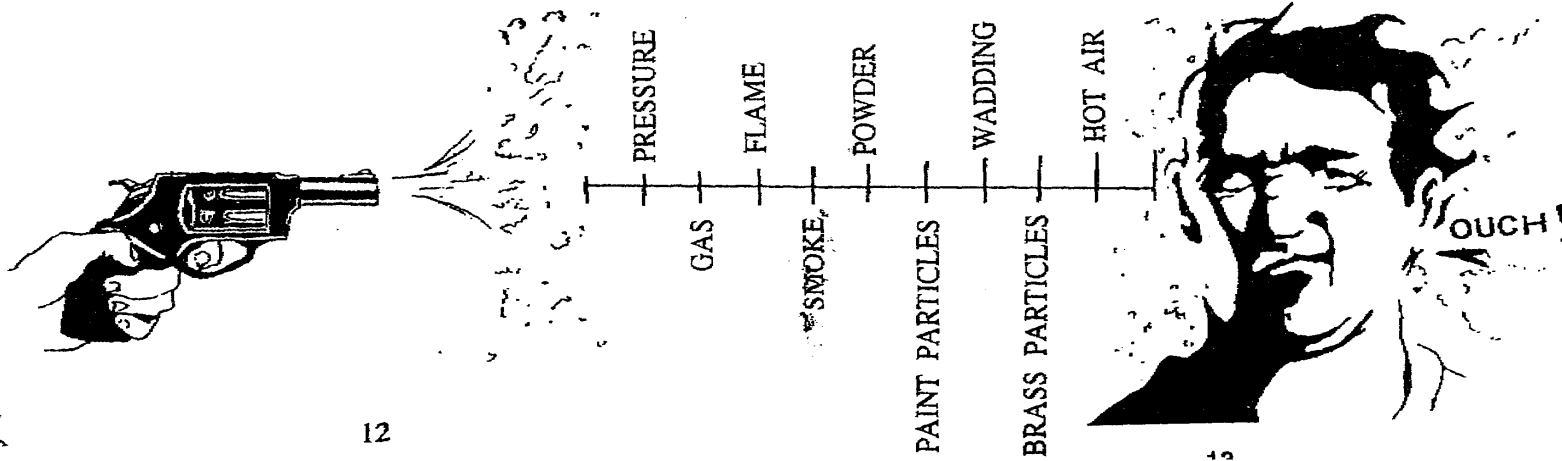

12

5



F.10

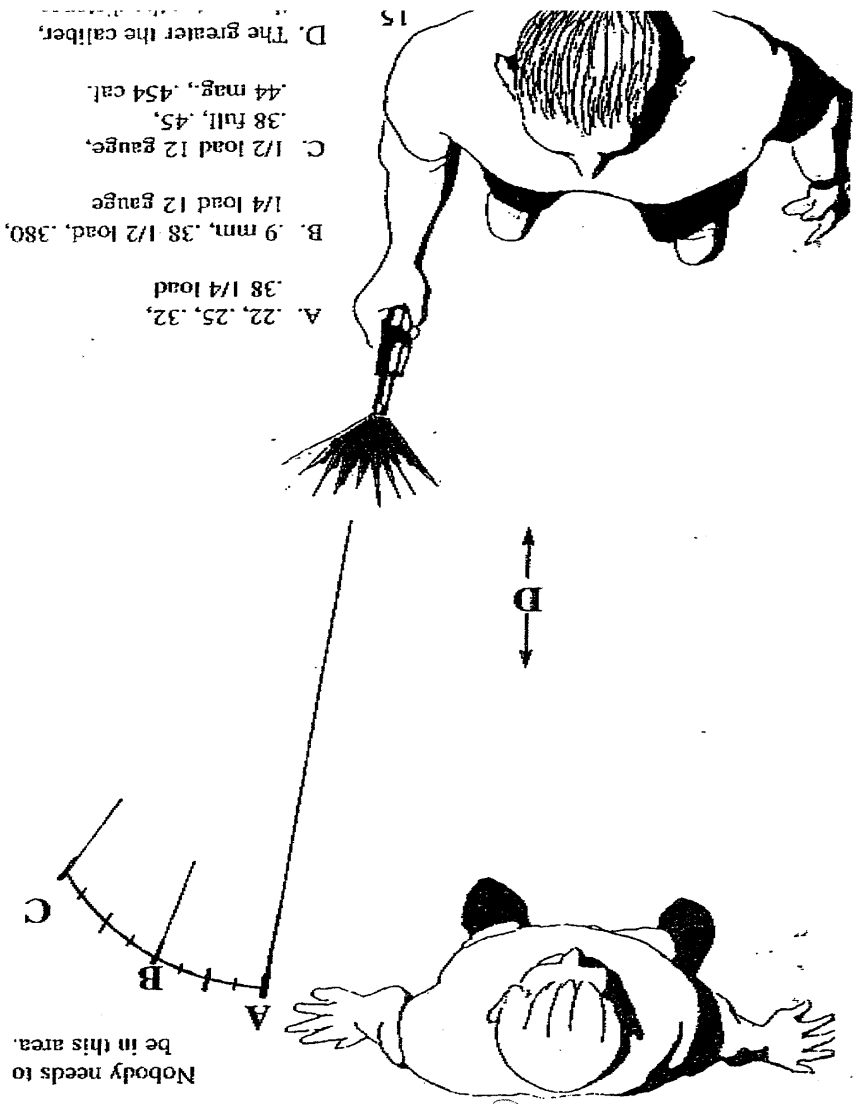

6-NOV-98 FRI 15:28

G3

P.10

"Common sense" guidelines should be understood and practiced by the prop master/weapons handler.

He or she *should*:

1. Instruct actors/stunt players in the proper use and function of the firearm they will be operating. Some actors have never before used a firearm. It is up to the handler/prop person to get everyone up to speed. If the handler cannot properly train an actor or stunt player to operate a firearm, he/she must inform the director or assistant director that a problem exists and make the necessary adjustments.
2. Have current and valid licenses or permits and be qualified to work with the firearms in possession and operation, whether the firearms are privately owned or company rented.
3. As the responsible party for distributing the firearms on the set, be sure that no one else is distributing any firearms. If it is necessary for another person to assist in the distribution of firearms, the prop master or weapons handler assumes the responsibility of making sure the assistant is qualified.
4. Inspect the firearm's cylinder, breach, receiver and barrel for any contamination before loading any blanks.
5. Only load the firearms prior to actual use for filming.
6. Make people aware that firearms are being loaded when installing the blanks, and allow actors/stunt players involved with the firing of the said firearm to watch the loading process if they desire.

When the "big scene" calls for a plethora of operation firearms, it is my suggestion to pace yourself in the following ways:

1. Have a walkthrough and safety meeting before filming.
2. Determine which firearms are most reliable, and have those placed closest to the camera.
3. Discuss with actors/stunt players the usual safety procedures you practice with regard to firearms. No harm in checking everyone a second time one-on-one.
4. Instruct the director or assistant director about safe zones of fire; i.e. brass, gas and wading. (See page 11)
5. Ask the director or assistant director as to their wishes in case of firearm malfunction during filming:
 - a. Have the actor/stunt player continue with the scene, with his/her finger in "ready" position, or
 - b. Have the actor stop and announce, "Dud" or "Stop."
6. Make sure everyone has the same message as to the possibility of malfunction. Chances are there may be a pyrotechnic special effect going on in the scene and you will only have one chance to "get it." Remember to *practice common sense*.
7. When the weapons handler/prop master hears, "Cut!" after the "big scene" or when there is a malfunction of a firearm, he/she should retrieve the malfunctioning firearm first, then the others in the predetermined order.

Do **NOT** permit any actor/stunt player to try to repair a malfunctioning firearm.

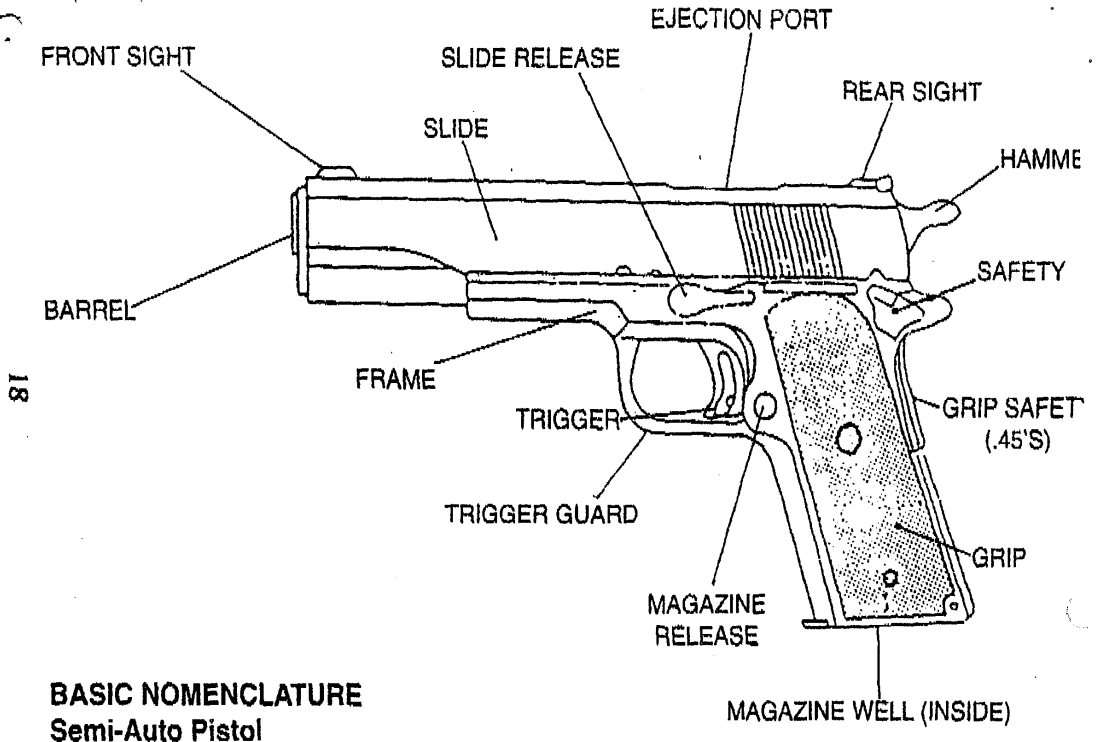

BASIC NOMENCLATURE
Semi-Auto Pistol

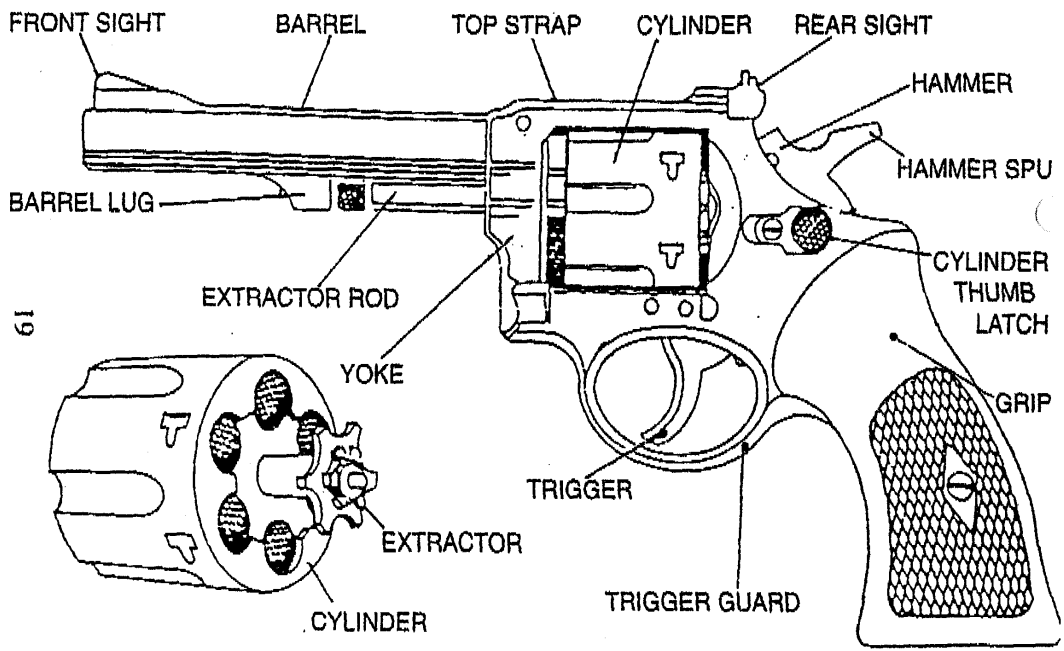

BASIC NOMENCLATURE
Revolver

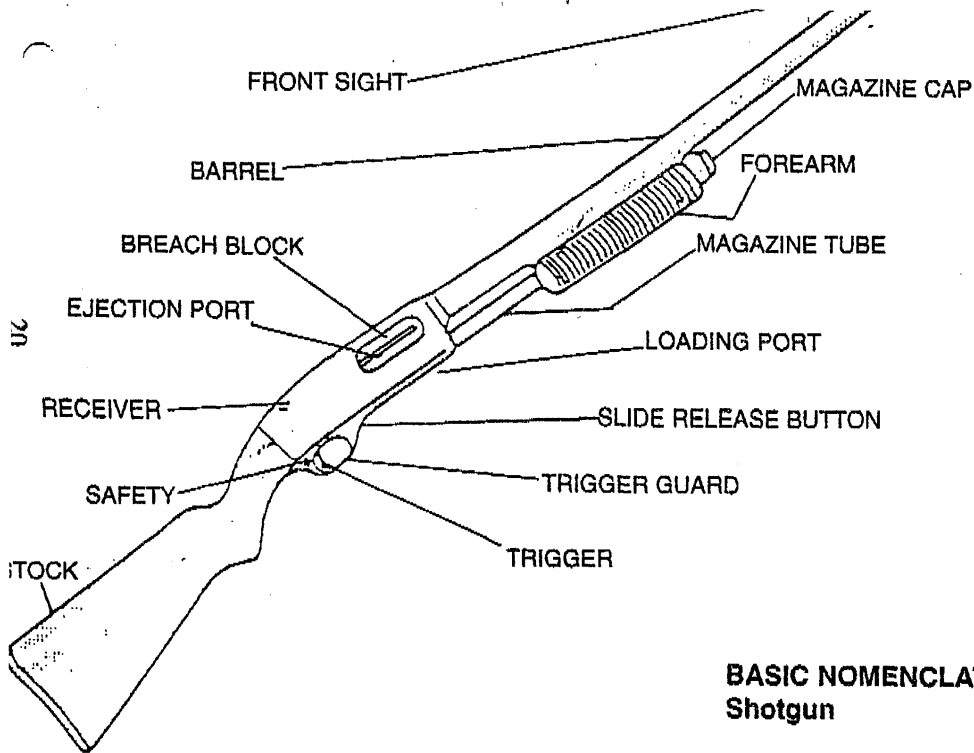

**BASIC NOMENCLATURE
Shotgun**

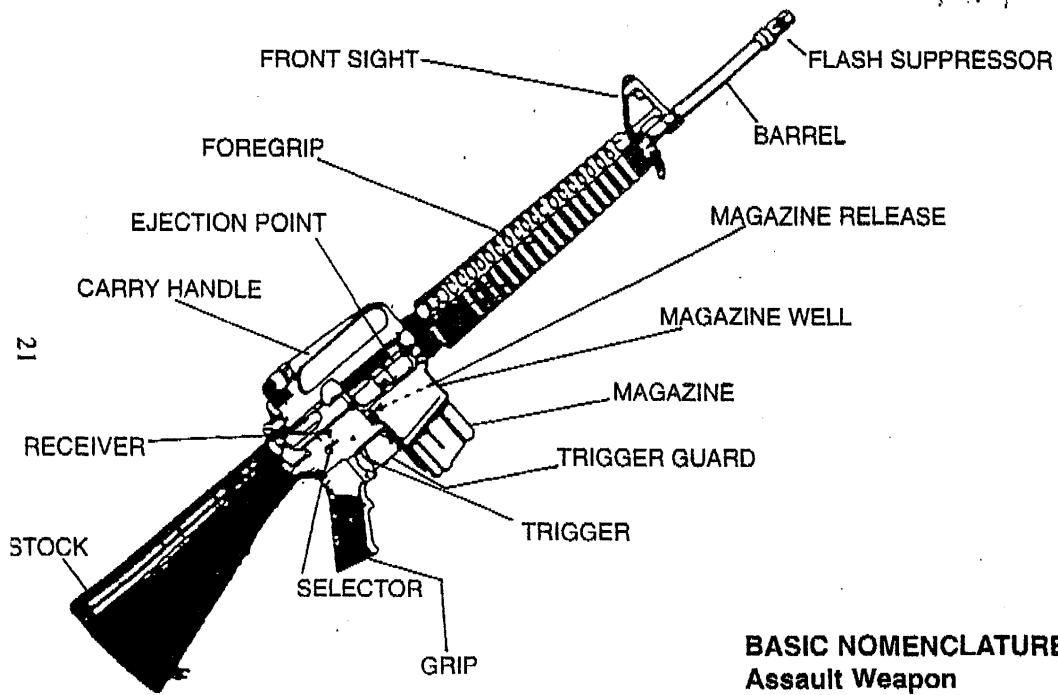

**BASIC NOMENCLATURE
Assault Weapon**

GLOSSARY

Ammo – An abbreviated term for ammunition, which is an object that is propelled out of a gun. a.k.a. round or bullet.

Assault Weapon – A type of gun which discharges each time the trigger is activated.

Barrel Restrictions – Metal fittings secured inside or out of a barrel to restrict gas to operate the bolt or eject brass.

B.F.A. – Used by Bureau of Alcohol, Tobacco & Firearms to describe weapons used in the entertainment industry - Blank Fire Adapted.

Blank – Term for a round or cartridge during burning or ignition and not a bullet.

Bolt – That part of a gun which takes a round forward into the receiver for discharge and then brings the spent round's brass back for ejection.

Brass – The metal most often used as the case or cartridge of a blank or bullet.

Centerfire – Bullet or blank that discharges when struck in the rear and center.

Charge – Often refers to a blank round of ammunition. Also reference to the act of injecting a round into the receiver.

Clip – An improper term used for a magazine which is where rounds are stored before discharge.

Crimp – The front part of a blank that is pressed closed to hold in the powder.

DAG – A brand of blank ammunition that is manufactured in Germany that uses a plastic tip.

Discharge – To shoot, or to fire, or to release a round or blank from a gun.

Dummy Round – A round that looks real to camera but is "inert" (i.e. no powders or primers).

Firearm – General term for a gun which includes revolvers, pistols, shotguns, and rifles.

Flash Suppressor – A fixture that limits by dispersion, the amount of flash that is visible coming out of the barrel when the gun is fired.

Foamies – A general term for foam inserts placed into the ears to reduce the decibels of noise. a.k.a. "ear plugs"

Full Auto – A gun that fires continuously with one pull of the trigger and continues firing until the magazine is empty, or trigger is released.

Gun – Usually a metal device that emits a bullet when operated by firing mechanisms within.

Pistol – A gun usually held in one hand that fires semi-automatic.

Revolver – A gun which contains a cylinder that rotates inside the frame to present a blank or bullet for the firing pin to strike.

Safety – On a gun, a device that is supposed to render the gun inoperable. **DON'T DEPEND ON THEM.**

Setaquette – A slang word that I use to describe a person's behavior on a movie set. (Etiquette)

Semi Auto – Pistols and assault weapons that discharge each time the trigger is pulled. One pull, one shot, until the magazine is empty.

Shotgun – A gun that releases lead or steel pellets in a group instead of a bullet.

Weapon – General term that includes all guns as a group.

P.14

G3

6-NOV-98 FRI 15:30

06-11-11000 15:30

P.15

BACKGROUND

Jefferson Wagner

Former L.A. Co. Sheriff Deputy reserve level 1
Current Cal. D.O.J. Basic firearms course provider
Current B.A.T.F. Class III Lic.
Current Cal. D.O.J. machine gun lic.
Current Cal. D.O.J. assault weapon lic.
Current Cal. D.O.J. short barrel shotgun, short barrel rifle lic.
Current Cal. State fire marshal pyrotechnic operators 3 card
Credits in over 100 feature films, foreign and domestic, for stunts
or weapons handling
Member S.A.G. 13 years

• Each of these pamphlets cost about one dollar of my own funds to produce.

Illustration Peter Carpenter
Layout Greg Carpenter
©1994

kinko's Copies

TOTAL P.15
P.15

G3

6-NOV-98 FRI 15:31

附頁 F

皇家香港警察總部
香港軍器廠街



ROYAL HONG KONG POLICE
HEADQUARTERS,
ARSENAL STREET,
HONG KONG.

編號 OUR REF.: (85) in CP LIC AQ 352/87

TELEPHONE: 5-284284

EXTENSION: 314

傳真 No.: 65367 HX

28 June 1988

Mr. HO Ying-hang, Eddie
Managing Director,
Props Co. Ltd.,
Unit 7, Lower G/F.,
Full Wing Building,
436-450 Chatham Road North,
Kowloon.

Dear Sir,

Dealer's Licence (Restricted) No. 282

I refer to the following arms which were forwarded to this Headquarters armoury for examination by my Ballistics Officer on 3 May 1988 to ascertain whether or not they have been suitably modified for firing blanks only :-

- (a) Five (5) 9mm Taurus PT92AF pistol S/Nos. L77121, L85141, L85143, L85144, and L85146 with magazines;
- (b) Three (3) 9MM SMG 12 rifle S/Nos. 02698, 02804 and 02878 with magazines;
- (c) Two (2) Taurus M85 .38 Spl. revolver S/Nos. G188418 and GL86577;
- (d) Two (2) 9mm Auto-Ordnance Corp pistol S/Nos. ADC11721 and ADC12057 with magazines;
- (e) Two (2) 9mm Norinco M213 pistol S/Nos. 205887 and 206271 with magazines;
- ✓(f) One (1) 8mm Replica Beretta M84 pistol S/No. NR03901 with magazine;
- (g) One (1) 9mm Beretta M92F pistol S/No. C713452 with magazine;
- ✗ ✓(h) Two (2) 9mm short revolver RG69 replica; and
- ✓(i) One (1) 8mm replica ROHM RG800 blank pistol with magazine.

The arms have now been examined and only the Rohm RG800, the Beretta model 84, the two Rohm RG69's pistol/revolver are found to be operated/designed for firing blank ammunition. You may now arrange with the undersigned to remove them from this Headquarters armoury. However, due care must be exercised not to purchase 8mm tear gas ammunition for the Rohm RG800 and the Beretta model 84 pistols.

...../The

P. 2

The modifications on the other firearms are found to be unsatisfactory. Please bear in mind that the modifications must be irreversible - presently in some cases it only takes a very short time to remove a plug simply by using a screw driver, and block the guns so that they remain completely safe.

You may adopt one of the following courses to dispose of the said items which are found not suitably modified :-

- (a) surrender them to me for disposal in whatever manner I consider adequate (copy of the disposal form is attached for your use);
- (b) export the items out of Hong Kong under a Limited Licence for Possession (copy of the application form is attached for your use);
- (c) arrange to have the items properly modified by a qualified gunsmith and resubmit them for examination.

Yours faithfully,

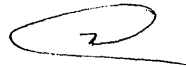

(CHAN Tit-shing)
for Commissioner of Police

致： 立法局 1999 年火器及彈藥（修訂）條例草案委員會

由： 全香港/視製作用槍械經營人

1999 年 3 月 4 日

代表公司：寶力道具有限公司

Hollywood Film Service Company

Film Tech Prop Services Ltd.

Combat Theatre Ltd.

事由：新草案對影/視製作業的影響

議員閣下，

保安局近日提交（修訂）草案予立法局，建議修改火器及彈藥條例（第 238 章），賦予警務處長更大權力，管制槍械及射擊會。如為了公眾安全，而進行有需要的法例修改，我們是贊同的。但建議中並沒有清楚解釋影/視製作用槍械與射擊用槍械的分別，而把兩者混為一類，強加不必要管制。在法理及實際需要上，完全是不合理及沒有必要。將會對影/視製作業造成沉重打擊。

因影/視製作用槍械是一種經過徹底改裝，不能再發射任何子彈類投射物的器械，並經由政府軍火專家檢驗合格，證明不能再發射投射物，才批准使用。此類器械祇能提供視覺效果，並不能稱之為‘槍械’。而現行之火器及彈藥條例（第 238 章）已就‘槍械’的定義有明確釋義。清楚闡明如任何器械產生投射物能量超過 2 焦耳，才能稱之為‘槍械’，以此界定其危險性及需要監管。不然，所有玩具用槍械如水槍等也被納入管制，徒然浪費人手，違背立法精神。

經過詳細諮詢業內意見，現謹代表全港影/視製作用槍械經營人，就建議中不合理之條文，提出反對及意見如下：

1. 草案第 2 條

(a) 建議在第 238 章第 2 條(h)段中，廢除‘發射’而代以‘鳴響’。

這是完全不適當的。此建議完全混淆以往清晰的‘槍械’定義。‘槍械’是一種器械能發射如子彈類之投射物，如使用不當，會對人畜生命構成威脅或破壞，故必須立例管制。但如一件物件或器械，完全不能發射投射物，沒有任何危險，祇會產生一種聲響效果，我們能否稱它為‘槍械’？

(b) 建議在第 238 章第 2 條加入新 ‘槍械’ 及 ‘彈藥’ 的定義。

這新定義不單把祇發出聲響及視覺效果之影/視製作用器材，強行界定為 ‘真槍械’。也把已完全廢除發射功能，無任何危險性，祇作掛牆裝飾用的失效火器及裝飾用的失效彈藥列作真槍械及真彈藥。強行加以實彈槍械類別之新釋義及刑責。如此胡亂更改法例及釋義，完全不適當。

2. 草案第 25 條

(a) 建議在法例 238 章第 52 條(1)(a)中力入 (ia),(ib),(ic)賦權警務處長決定某人是否適宜擔任槍械導師及該等課程的內容及範圍。

設立槍械導師一項，在安全原則上，我們是完全同意及支持的。多年以來，各經營人已在拍攝期間，派遣已受訓練技師跟隨指導和監管。而各技術人員受僱前，都已事先向警方槍械牌照科申請及獲得批准。並不存在有不適當人仕士參予工作。但建議的修訂法案，主要為指導他/她人作實彈射擊安全而設，對影/視製作用槍械並不適用。

因影/視製作用槍械在操作原理及安全層面要求上，與射擊用槍械不盡相同，部份更與警方之訓練要求完全相反。影/視製作要求的祇是視覺效果而非射擊目標，加上製作用槍械，因應商業需求，來自世界各地，種類繁多，並非任何一個單一政府的常規裝備可比擬。任何國家或地方，都沒有為此類別之槍械提供技術訓練及支援。故經營人公司除為新僱員提供一般槍械操作安全知識外，也特別為電視/電影製作設計一套特別之安全守則，內容全靠工作經驗累積而成，一般的考核要求，並不適用此行業。

業內意見：我們建議有關當局，不要草率通過有關法例。必須把製作用槍械導師及射擊用導師分辨清楚，向各相關機構如影視及娛樂事務管理處及業內人仕進行詳細諮詢及研究，設定一套專為業內工作人員訓練及考核要求，才通過決定此類別導師之資格及條件。

(b) 建議修訂法例第 238 章第 52 條(1)(a)(iii)賦權警務處長限制槍械及彈藥數目。

此法例必須清楚闡明，若胡亂釋義。很容易被濫用。警方牌照科現正不合理地限制電影製作業及演員使用道具槍械數目（如每名演員不可使用多過 2 枝，及整部電影製作申請總數又不能多過 20 枝），這是嚴重侵犯創作自由及不合理地限制合法商業活動。我們認為祇應該賦權警方決定該器械是否安全及符合法例使用，而不應干預創作自由及限制商業機構的資產增長。

香港製造的動作電影及道具槍械技術，在世界上已名列前茅。曾贏得無數稱譽。政府應該對此行業採取一個肯定及支持的態度，而不應該背道而馳。

(c) 建議廢除第 238 章第 52 條(1)(b)及(d)

建議廢除之‘訂明表格’為前立法局經多番研究後訂下，行之有效。而新表格並未見提交審議，對此建議不敢贊同。

(d) 建議在法例第 238 章第 52 條(1)©款中加入‘須繳付的費用，決定第(1)(a)(ii)及(iiia)款所提述的事宜須繳付的費用，槍械的檢驗須繳付的費用’。

此建議完全是不合理及擾民之舉。草案建議先否定槍械管有牌照持有人教導他人作射擊練習的資格，他門必須再通過考試，才被警務處長授權為槍械導師，但他/她必須自行繳付費用。完全是不合理的。

更甚者，規定已檢驗合格的電視/電影製作用的槍械每年必須重新交回警方檢驗。所牽涉的行政程序及意圖徵收高昂的檢驗費用，將直接令整個行業倒閉。

影/視製作用槍械與實彈射擊用槍械並不相同。射擊用槍械（俗稱真槍）是擊發火藥，以高速度發射出一粒俗稱‘子彈’的投射物，是一種必須小心處理之武器。但影/視製作用槍械則是一種經過徹底改裝，動作結構與真槍完全不同，不能再發射任何投射物之器材。外形雖仍保留為一支槍械，但已完全失有了真槍之危險性。而多年來，警方槍械牌照科已聯同其軍火專家，為電視/電影製作用槍械制定了一套嚴緊的改裝標準。每支此類型製作用槍械，都必須經過槍械鑑證科軍火專家嚴格檢驗，證實沒有真槍性能，不能再發射子彈及符合安全標準，才會批准使用。而此種檢驗及經營方法，現全港 4 個持牌經營人一直持續使用，從沒有問題發生。

建議中每年再重覆檢驗，實無此需要，究其原因：

- (i) 每一支已發牌之製作用槍械，都已經由同一部門之軍火專家檢驗合格，證實不能發射真彈及發出安全證明。並不存在任何不合法或危險。按現火器及彈藥條例定義，根本不屬‘槍械’。若建議要每年再重覆檢驗，是否合理及有此需要？
- (ii) 經營此類別槍械之執照，在香港共有 4 間。合共擁有超過 1,200 枝已完全改裝合格之製作用槍械。除供應香港本地電視/電影製作外，亦提供租用服務予鄰近地區及國家使用。此大數量之製作用槍械，乃經營人們自 1987 年開始以來，共花

12 年時間積聚而成。如每年再作無謂的重覆檢驗，在專家人力資源上，絕對不足以應付。軍火專家一職，都需要從無數工作經驗實踐積累而成，並不能隨意的增加人手或撥款可行。如勉強為之，因經驗及人手不足，檢驗需時，勢將造成大量錯誤及積壓。浪費公帑。而每年重驗之舉，也會名存實亡。這對經營人在經濟上也勢將造成重大損失。

- (iii) 在現今社會經濟低迷，電影行業正處於崩潰邊沿。罔行改變一套已進行有效監管及安全運作之機制，強加不必要的要求，這完全是不切實際的擾民之舉。
- (iv) 如實行建議，每年每月甚至每日都將有大量不必要的槍械及彈藥（供軍火專家試驗）往來於經營人及中區警察總部的槍械庫途中，送檢或取回。增加了雙方面不必要的文書工作及公眾曝光率，惶論精簡架構，對社會安全，也產生負面影響。
- (v) 影/視製作用槍械提供的祇是螢光幕上視覺效果，並沒有射擊用槍械的危險性。每次使用前後，都經由受訓練技術員詳細檢查及看管。使用時，也祇局限在指定空間（片場/外景場地），供領有豁免許可證之演員使用。偶有機械故障，也是一些非危險性的技術問題，絕對可以由跟隨之技術員即時修理。對公眾人仕，完全不構成任何危險或傷害。而建議中之每年交回警方重覆檢驗，並不能幫助或保證拍攝時機械正常操作。祇徒而干擾行業之正常運作。增加負擔。
- (vi) 而已批准使用之製作用槍械，祇有少部份會經常使用外，大部份種類都祇是儲存及等候電影公司挑選。若未經使用而要求每年重驗，實屬不合理。

再者：自香港回歸以來，多名有經驗之軍火專家相繼離職。部門形成斷層。正常之檢驗工作也曾停頓了兩年。直至近日才接受正常檢驗申請。但相信基於新專家祇曾接受射擊用槍械訓練，而對影/視製作用槍械經驗不足，錯誤及爭拗常有發生。現建議有關部門先向業內人士諮詢意見，共同合作，以確保安全及有效運作。

業內意見：我們堅決反對已檢驗合格的影/視製作用槍械每年需要送回警方作重覆的無謂檢驗。但我們同意每一支新改裝完成的影/視製作用槍械，當經過徹底改裝後及可以用作拍攝前，都必須先送往警方軍火專家進行安全測試，經檢驗及格，才批准使用。

但一經檢驗合格，可依據現行火器及彈藥條例（第 238 章）第 52 條把該器械界定為 ‘非槍械’，以後的租用條例及監察工作，

則交由影視及娛樂事務管理處專責處理。因一支已完全改裝之製作用槍械，已經失去了殺傷性功能，其危險性就祇如一件普通機器，需要注意的是機器操作上的安全。而影視及娛樂事務管理處聘有專業顧問，較了解影視製作業的運作及採取較肯定的態度，例如一向被各政府部門避不沾手的特技煙火爆破問題，經該處向外國尋求專家協助下，成功設立訓練及考試制度，使此技術能有健康發展。

反觀影/視製作用槍械，一向已受槍械牌照科及危險品礦務科嚴格監管，一套行之有效而又安全的措施，**12**年來已完全立入正軌。但因保安局及警方近年採取負面態度，濫用法例賦予之權力，連續施行不合理措施，使到影視製作業萎縮不前，現在又試圖修訂及加入不合理條文，罔加更苛刻經營條件，屆時此行業必然全面倒閉，對日漸色微的電影工業，無異雪上加霜，受影響就業人數，無法估計。

我們明白保安局的建議是純粹從保安角度單方向出發，對特殊技術行業採取比較負面態度，而不會考慮經濟因素。但香港電影業現正陷入困境，瀕臨崩潰邊緣。特區政府及特首也為此設立基金，讓資訊科技及廣播局，暨影視及娛樂事務管理處專責處理。以匡扶電影工業。我們也深切希望各立法局議員們能從法理，保安及經濟等多方面原則考慮，不要罔向影/視製作業再落井下石。執行不合理措施。

此致

立法局各議員

經營人代表：

實力道具有限公司 - 何應衡 (Tel: 2765-8266, Fax: 2363-6786)

Hollywood Film Service Company - 潘志文 (Tel: 2364-6661, Fax: 2363-3482)

Film Tech Prop Services Ltd. - 何孟強 (Tel: 2693-3231, Fax: 2601-5245)

Combat Theatre Ltd. - Fred Yau (Tel: 9081-9084, Fax: 2651-6888)

副本送：

影視及娛樂事務管理處處長（經辦人：麥華雄先生）

資訊科技及廣播局局長（經辦人：蔡釗嫻女士）

香港影業協會（執行總幹事：叢運滋先生）

香港電影導演會（張同祖先生，陳嘉人先生，董瑋先生）

香港電影製作發行協會（舒達明先生）