

**For discussion
on 18 May 2000**

**LEGISLATIVE COUNCIL
PANEL ON PLANNING, LANDS AND WORKS**

**Hong Kong 2030: Planning Vision and Strategy
Brief Notes on Study Approach**

PURPOSE

This paper is to brief Members on the new approach to update the Territorial Development Strategy (TDS), to be called 'Hong Kong 2030: Planning Vision and Strategy' (Strategy 2030).

BACKGROUND

2. The last review of the TDS was completed in 1996. Since then, some fundamental assumptions underlying the review have become outdated (e.g. population projection, economic growth rates) and some new factors having strategic planning implications have emerged (e.g. China's imminent entry into the World Trade Organisation, the increasing socio-economic interactions between Hong Kong and the Mainland). We have undertaken to start a new round of review to assess Hong Kong's future development needs in a wider regional perspective and for a longer time horizon.

3. In February 2000, the Commission on Strategic Development (CSD) released its first report which provides an overview of the key issues that will impact on Hong Kong's future development. The planning dimension of the four strategic themes which are considered to drive Hong Kong's long-term development, i.e. strengthening links with Mainland, enhancing Hong Kong's competitiveness, improving quality of life, and reinforcing identity and image, will be articulated in Strategy 2030.

A NEW APPROACH - KEY ELEMENTS

4. Strategy 2030 is intended to provide a long-term land use-transport-environmental planning framework for the territory. It will articulate the Chief Executive's vision and include a package of physical planning measures to realise this vision as well as the CSD's recommendations. A summary of the key areas relating to CSD's strategic themes which will be studied is at Annex A.

5. The approach for the preparation of the Strategy 2030 comprises the following key elements : -

- (a) A Longer Planning Horizon: Having considered the time required to plan and implement strategic development and related infrastructure proposals, a 30-year planning horizon (from 2000 to 2030) is proposed to be adopted for Strategy 2030. This time-frame also tallies with the CSD's strategic framework. A longer time-frame than this could reduce the reliability, practicability and usefulness of the planning strategy.
- (b) A Shorter Review Period: The last review took more than six years to complete. The review process was regarded as unduly elaborate. It is proposed that the preparation of Strategy 2030 should be completed in 18 months, excluding the last stage of public consultation.
- (c) A More Focused Approach: In order that Strategy 2030 could be completed within a much shorter time-frame, it would need to focus on key planning issues only (see para. 6(c) below). Many other issues, which have already been the subject of separate studies, will be consolidated to serve as inputs into Strategy 2030.

- (d) More Flexible and Responsive Strategy: Apart from postulating different scenarios and formulating corresponding development strategies, Response Plans will also be prepared to set out some broad guidelines on how to adjust the development framework in response to changes in population levels as well as environmental and socio-economic conditions. A regular monitoring and review system is also proposed to trigger ‘prompt’ responses to changing circumstances.
- (e) Linkages with the Mainland: Strategy 2030 will study Hong Kong in the Pearl River Delta region, particularly its socio-economic linkages with other cities in the region, in view of the rapid growth of cross-boundary interactions in the recent years. The interface between physical planning in Hong Kong and Shenzhen will also be studied in formulating our Strategy (see para. 2(a) of Annex A).
- (f) More Public Involvement: The process to prepare Strategy 2030 will be made more transparent to respond positively to the demand for more public consultation. It is proposed to involve the public throughout the entire process for Strategy 2030 through a multi-stage, proactive approach (see para. 10 below).

KEY WORKING STAGES

6. The preparation of Strategy 2030 would involve four key stages of work as follows:

Stage One: Agenda Setting and Baseline Review

- (a) The objectives and key issues to be covered by Strategy 2030 will be drawn up to serve as the ‘agenda’ for the review to proceed. Also, an

extensive public exercise will be carried out at the early stage to solicit public views on the future development of Hong Kong.

- (b) The baseline conditions in respect of the provision of public and private housing, general and specialised industrial land, commercial land and land for other uses including conservation and tourism will be established. In addition, the baseline environmental profile and transport network will also be established. Work relating to this task has already commenced by in-house study.

Stage Two: Examination of Key Issues

- (c) Subject to the public consultation exercise, it is proposed to undertake detailed examination of the following topics:
- Population Forecasts and Housing Land Requirements;
 - New Development Opportunities;
 - Socio-Economic Integration with the Mainland;
 - Environmental Considerations and Conservation;
 - Potential for Tourism, Recreation, Art and Culture Development;
 - The Development of Innovative Technology and its Implications on Landuse; and
 - Requirements of Port and Other Major Infrastructure Facilities.

Stage Three: Scenarios and Options Formulation and Evaluation

- (d) Based on the variations of key planning parameters such as population growth, economic growth, Mainland's economic growth and ease of cross-boundary movement, etc., a number of development scenarios will be formulated and evaluated against a range of performance criteria covering the land use, environmental and transport aspects.

Stage Four: Formulation of Development Strategies and Response Plans

- (e) Flexible strategies would be proposed, covering a range of time frames within the planning horizon with different degree of details for the planning proposals. Proposals for the short and medium-term would be more specific so that they can be taken forward for detailed feasibility studies and infrastructure planning; whereas proposals for the long term would represent options and possibilities for longer term development for which broad-brush planning assessment could be conducted.

7. A flowchart showing the key tasks proposed to be undertaken at each stage is at Annex B.

FUNDING ASPECT

8. The total estimated cost for preparing Strategy 2030 is about \$15 million (inclusive of specialist staff and non-staff expensive). While the assistance of some specialist consultants including economists, environmental specialists, traffic analysts and publicity and public relations specialists is needed, we will utilise in-house resources as far as possible.

9. Funding is also required for publicity (e.g. report compilation/production for the public consultation exercises), acquiring information, visits and maintaining liaison with Mainland authorities and conducting various ad hoc surveys relating to the review. We will proceed to seek Finance Committee's approval for the funding in due course.

PUBLIC CONSULTATION

10. Through the various public consultation forums and publicity through the Web site, the public could put forth their ideas and views on the future development of Hong Kong. The ideas and views raised by the public would, in turn, help define the planning objectives, guide the formulation of planning strategies and provide views on the recommended options. We hope through more vigorous and extensive consultation, some degree of community consensus could be obtained on the recommended strategy. A broad public consultation strategy is at Annex C for Members' reference. A press release will be issued upon commencement of Strategy 2030.

ATTACHMENT

- Annex A : Interface between CSD Report and Strategy 2030
- Annex B : Methodology Flowchart
- Annex C : Public Consultation Strategy

Planning and Lands Bureau
May 2000

INTERFACE BETWEEN CSD REPORT AND STRATEGY 2030

1. The Commission on Strategic Development (CSD)'s first report has outlined four strategic themes that Hong Kong must address in its long-term development, namely:
 - (a) Strengthening Links with the Mainland;
 - (b) Enhancing Competitiveness;
 - (c) Improving Quality of Life; and
 - (d) Reinforcing Identity and Image.

2. In terms of these themes, the following key aspects will be studied, or considered, in preparing our Strategy 2030:
 - (a) Strengthening Links with Mainland
 - the spatial development patterns in the Pearl River Delta (PRD) region, particularly, the respective roles for major urban centres including Guangzhou, Zhuhai, Shenzhen, Macau and Hong Kong;
 - the positioning of Hong Kong in the regional development of PRD and strategic planning implications;
 - ways to enhance socio-economic integration covering such aspects as housing, social facilities, tourists/recreational facilities, business, port facilities etc.;
 - patterns of cross-boundary travel and need for additional crosslinks; and
 - the interface between urban development on both sides of the boundary including the development potential for the boundary area.

 - (b) Enhancing Hong Kong's Competitiveness
 - challenges and opportunities arising from China's accession into the World Trade Organisation, in particular how land and infrastructural planning can help meet the challenges and maximise opportunities;

- land and physical infrastructure required to sustain our long-term development, particularly in strengthening and enhancing our hub functions;
- planning initiatives required to help widen our economic base into such areas as tourism, high-tech and high value-added industries etc; and
- scope for new business centre(s) away from the Central Business District.

(c) Improving Quality of Life

- adopt sustainable development as the key principle in strategy formulation;
- devise and update the planning framework for the conservation of our natural environment, preservation of our cultural heritage and protection of areas of high landscape value;
- undertake a strategic environmental assessment for the proposed development strategy and strengthen environmental planning guidelines to guide our future planning and development; and
- better distribution of population and jobs to minimise travelling; and
- an integrated planning framework for arts and cultural facilities.

(d) Reinforcing Identity and Image

- explore tourism potential, other than the international theme park, based on our unique East-meet-West characteristics, including both project and area-based attractions; and
- incorporate the Harbour Plan and Urban Design Guidelines, currently being prepared, as part of Strategy 2030.

Methodology Flowchart

Enclosure 2 to FCR(00-01)_____

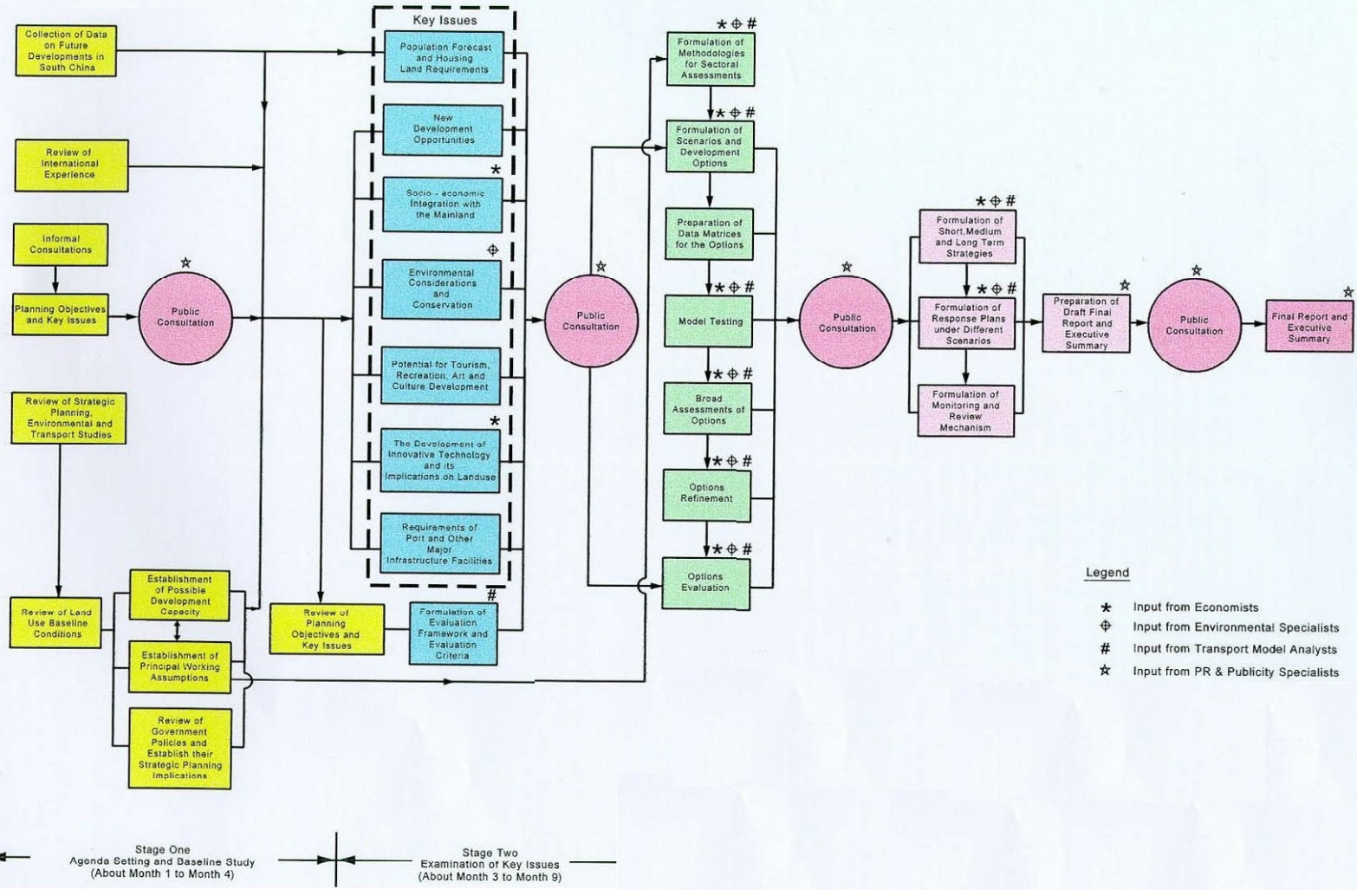

PUBLIC CONSULTATION STRATEGY

Introduction

1. Strategy 2030 will set out proposals for Hong Kong's future development, and will touch upon many matters/issues that are of major concerns to the public. It is essential to provide adequate public consultation in the formulation of Strategy 2030. In this connection, a public consultation strategy has been prepared to outline the objectives and tentative programme for various consultation activities.

Objectives

2. The objectives of the consultation strategy are as follows :
 - (a) to solicit views, comments and suggestions and hence foster community consensus on the planning objectives, key issues to be addressed, evaluation criteria that should be adopted as well as the essential elements of the preferred development strategies and response plans;
 - (b) to instil a sense of partnership among the Government and the stakeholder groups on the preparation of Strategy 2030; and
 - (c) to raise the awareness of the general public of the preparation of Strategy 2030 and encourage public participation thereby gaining wider recognition of the strategic planning efforts of the Government.

Target Audience

3. This public consultation exercise will target at two general groups of people.

Members of the General Public

4. It is expected that their views and comments will be very general, broad and diverse. However, it is important to gauge the community's expectation and aspirations for the future development of Hong Kong.

Stakeholder Groups

5. Views, comments and suggestions to be raised by stakeholder groups will likely be more focused and substantial, reflecting their respective areas of interest. Their views will be important in identifying key issues that need to be addressed and the essential components expected of Strategy 2030. We will consult the following stakeholder groups:

- (a) Statutory and Advisory Bodies
- (b) Legislative Council and other Elected Bodies and Political Parties
- (c) Business and Community Organizations
- (d) Academic and Professional Institutions

Content of Consultation

6. We will solicit public views on the following aspects :
- (a) Planning Objectives and Key Issues to be Examined
 - (b) Findings on the Examination of Key Issues and Evaluation Criteria
 - (c) Scenarios and Development Options and Results of Evaluation
 - (d) Development Strategies and Response Plans

Channel

Public Forums

7. Public forums will provide opportunities for stakeholder groups and interested members of the public to express views and comments.

Focus Group Discussions

8. More focused discussions with stakeholder groups will be organised to present our work and solicit their advice and suggestions, particularly on issues that may have implications on their respective fields. We will arrange focus group discussions throughout the entire process of Strategy 2030.

Presentations to Statutory and Advisory Bodies

9. We will also arrange presentations to statutory and advisory bodies to obtain their views and comments.

Web-site

10. The consultation documents and all working papers and technical reports will be uploaded to the web-site of Planning Department. We will invite written comments, either through the internet or by post to Planning Department.

Through the Media

11. We will also promulgate our work through the media, either by way of press releases or informal/formal briefings to the press. We will collect public views and comments on our work through the press and other media.

Consultation Papers, Information Leaflets and Other Materials

12. To facilitate the consultation activities, consultation papers, information leaflets and videos will be prepared. We will seek the assistance of the publicity and public relations specialists in preparing the publicity materials and conducting various public discussion forums. We also intend to arrange exhibition(s) at appropriate stage(s) of Strategy 2030.