



# **UltraLyte 100 LR Laser Gun**

## **Force Training Notes**

**Traffic Branch Headquarters Version 1**

## **Preamble**

These Force Training Notes (FTN) explain how to use the 'UltraLyte 100 LR' laser gun when conducting speed check operations. The FTN are divided into three chapters :

Chapter 1 : Basic Function and Operation of the Laser Gun

Chapter 2 : Guidelines on Laser Gun Speed Check Operations

Chapter 3 : Testing Facilities within Traffic Regions and Responsibilities of the Management.

The FTN are written in accordance with the Manufacturer's User Manual provided by the manufacturer. However, for easy understanding and to focus on law enforcement, some technical contents have been simplified. Traffic Branch Headquarters have widely consulted all Traffic Formations to ensure the FTN are of a professional standard. The FTN have been endorsed by an independent laser gun expert, Dr. TAM Wing-yim, from the Hong Kong University of Science & Technology and by the Hong Kong authorised agent of the laser gun manufacturer.

The SSP Traffic must ensure that all speed check operations conducted within their Region fully satisfy the requirements of the FTN.

The FTN are written in both English and Chinese versions, the English version takes precedence. If an officer has any doubts about the FTN and the use of the UltraLyte laser gun, they should approach a qualified trainer in their Formation for clarification. Any amendment to the FTN must be approved by Traffic Branch Headquarters (CSP Traffic).

Traffic Branch Headquarters  
March 2008

## **Table of Contents**

### **Preamble**

#### **Chapter 1 Basic functions and operation of the laser gun**

- 1-01 Introduction
- 1-02 Anatomy of the UltraLyte
- 1-03 Sensors
- 1-04 Batteries
- 1-05 Powering on and off
- 1-06 Screen
- 1-07 Sighting scope
- 1-08 Stock and tripod
- 1-09 Button panels
- 1-10 Menu options
- 1-11 In-scope display intensity
- 1-12 Speed limit
- 1-13 Basic speed measurement
- 1-14 Muting the instrument
- 1-15 Power conservation intervals
- 1-16 Precautions when using the instrument
- 1-17 Maintenance
- 1-18 Checking the model number
- 1-19 Specifications

#### **Chapter 2 Guidelines on laser gun speed check operations**

- 2-01 Introduction
- 2-02 The roles and qualifications of officers
- 2-03 Points to note upon the collection of the laser gun and relevant equipment
- 2-04 Checks to be conducted before and after operation
- 2-05 Procedures of instrument checks
- 2-06 The selection of speed detection locations
- 2-07 Points to note during speed check operations
- 2-08 Measuring the speed of a moving vehicle
- 2-09 The JAM indicator

- 2-10 Error conditions
- 2-11 Error codes
- 2-12 Keeping records
- 2-13 Making a record in police notebook

**Chapter 3 Testing facilities within Traffic Regions and responsibilities of the management**

- 3-01 Introduction
- 3-02 Laser gun basic testing facilities within Traffic Regions
- 3-03 Traffic Regions choosing locations for speed check operations
- 3-04 Responsibilities of management
- 3-05 Proper storage of the laser gun

- Annex**
- 1 Laser Gun Operator Record
  - 2 Laser Gun Speed Detection Record
  - 3 Operator checklist

# **Chapter 1**

## **Basic functions and operation of the laser gun**

## Chapter 1

### Basic functions and operation of the Laser gun

#### 1-01 Introduction

The UltraLyte 100 LR laser gun is a hand-held laser speed detection and ranging device. It measures and displays the speed of a moving vehicle and the distance at which the speed was measured. This chapter includes the anatomy of the UltraLyte, notes on using the instrument and its maintenance.

#### 1-02 Anatomy of the UltraLyte

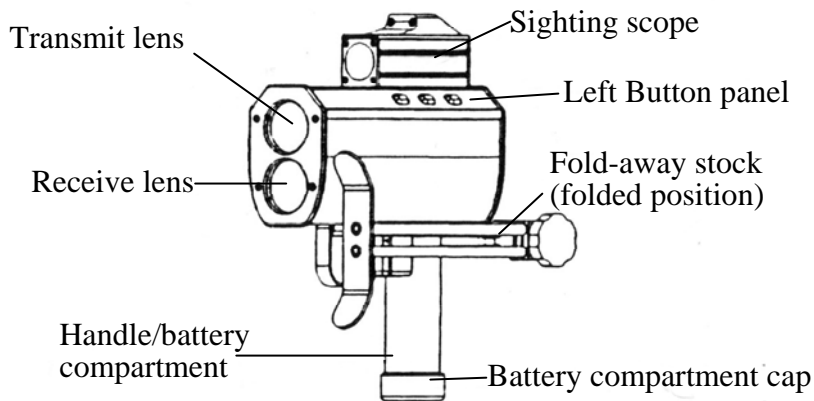

Diagram 1 :  
Front/left side

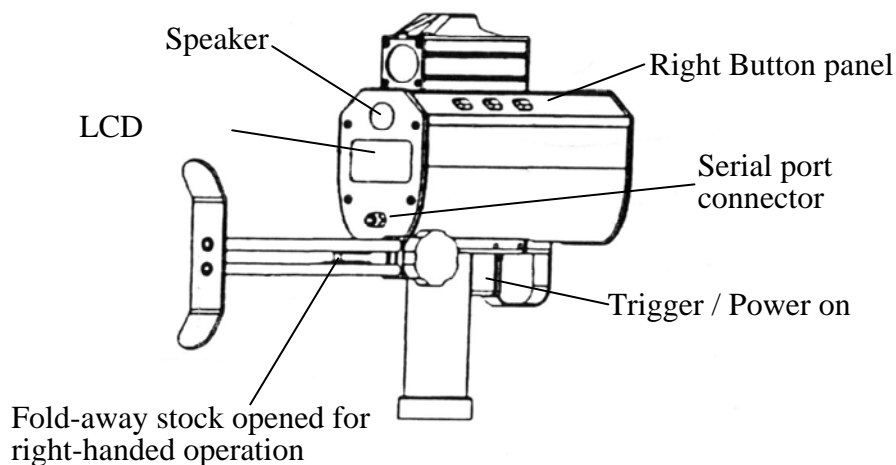

Diagram 2 :  
Back/right side

### 1-03 Sensors

The UltraLyte has two lenses on the front panel. The top lens transmits infrared laser signals; the bottom lens receives signals back from the target and feeds signal information to the internal circuitry.

### 1-04 Batteries

Load two C batteries by inserting them positive-end-first into the battery compartment in the instrument handle. (Warning : The UltraLyte is designed to accept normal C-cell batteries. NiCad batteries can be used, but they tend to vary in size. The authorised agent will not be responsible for damage that results from trying to force NiCad cells in or out of the battery compartment.)

2. The instrument continuously monitors its power source. If you want to check the battery voltage, you keep pressing the *TEST/EDIT UP BUTTON* on the left middle row three times until the screen displays the voltage reading on the right lower corner, as shown in diagram 3.

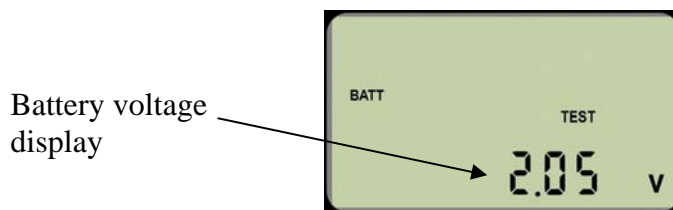

Diagram 3

3. If the battery voltage drops during operation, the BATT indicator blinks :-

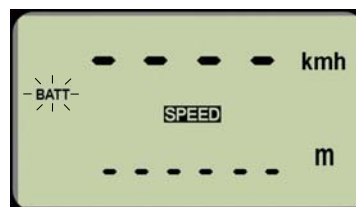

Diagram 4

4. If the voltage drops even further, the button panels lock out.

### 1-05 Powering on and off

Power the instrument on by simply pressing the trigger. Power off by pressing the *BACKLIGHT/EDIT DN BUTTON* and keeping it pressed for about 2.5 seconds (see 1-09 on this chapter for details).

2. After powering on the instrument, it will conduct the following two tests automatically :-

- (a) Instrument self test; and
  - (b) Testing display integrity.
- } [see Chapter 2 for details]

**1-06 Screen**

The screen displays measurements and option indicators. When the instrument is powered on, for example, the speed measurement screen displays :-

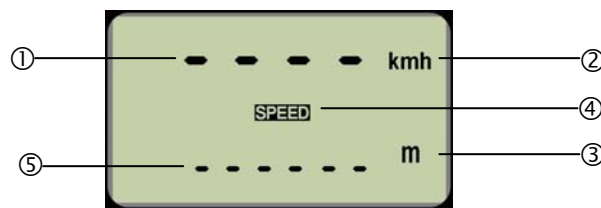

Diagram 5

- ① indicates the speed measurement
- ② indicates the speed in km/h
- ③ indicates the distance in meters
- ④ indicates the instrument in speed measurement mode
- ⑤ indicates the distance for the speed measurement

**1-07 Sighting scope**

An adjustable polarizing light filter to optimize viewing contrast

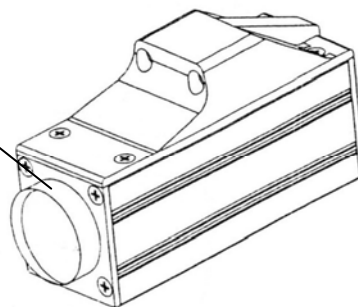

Diagram 6 :  
Scope Exterior

An in-scope, red aiming dot to help you aim accurately at the target

An in-scope measurement display showing the detected speed



Diagram 7 :  
In-scope Display



**1-08 Stock and tripod**

The laser gun is designed to be used in conjunction with a stock, stand or tripod. Under normal circumstances, police should use a tripod during speed check operations. Please refer to Chapter 2 for details.

**1-09 Button panels**

The instrument has two 3-button panels, one on each side of the instrument. The buttons give you access to instrument functions as follows :-



Diagram 8 :  
Right Button Panel

Button	Button Name	Function
①	<i>MENU / OPTIONS</i>	Select functions in the menu options.
②	<i>SURVEY / OPTIONS</i>	Not applicable (function deleted).
③	<i>SPEED / OPTIONS</i>	Activates the speed measurement mode.



Diagram 9 :  
Left Button Panel

Button	Button Name	Function
④	<i>SELECT / EDIT</i>	<ol style="list-style-type: none"> <li>1. Press and release : Selects option values in the function menu.</li> <li>2. Press and hold for 2.5 seconds to select a digit to be edited.</li> </ol>
⑤	<i>TEST / EDIT UP</i>	<ol style="list-style-type: none"> <li>1. Activates the instrument's test mode.</li> <li>2. In speed limit edit mode, adds numerical value to the currently selected digit.</li> </ol>
⑥	<i>BACKLIGHT / EDIT DN</i>	<ol style="list-style-type: none"> <li>1. Press and release : Turns the display backlight on/off.</li> <li>2. Press and hold for 2.5 seconds : Turns the instrument off.</li> <li>3. In speed limit edit mode, subtracts numerical value from the currently selected digit.</li> </ol>



**1-10 Menu options**

The following table lists the options available through the *MENU / OPTIONS BUTTON* :-

Indicator	Option	Explanation
br	Display Intensity	Varies the in-scope display brightness.
GS	Gate - Short	Artificially restricts the minimum range of the instrument.
G L	Gate - Long	Artificially restricts the maximum range of the instrument.
SL	Speed Limit	Sets an alarm tone to indicate when a target is exceeding the speed limit.
CONT	Continuous mode	The instrument measures the average speed of a target over an operator-determined measurement time (note : police will not use this function during law enforcement).
MUTE	Mute mode	Toggles instrument indicator sounds on/off.
ALL on	Power Time-outs	Toggles instrument and display time-outs on/off.



**1-11 In-scope display intensity**

The intensity of the in-scope red dot and display can be adjusted from the darkest (br 00) to the brightest (br 21).

Action	Result
1. Press <i>MENU / OPTIONS BUTTON</i> until the screen displays the br xx option (xx is the current setting).	
2. Press <i>TEST / EDIT UP</i> or <i>BACKLIGHT / EDIT DN BUTTON</i> until the setting is correct.	
3. Press the <i>SPEED / OPTIONS BUTTON</i> to return to the speed mode. Press the <i>MENU / OPTIONS BUTTON</i> to go to the next menu option.	

**1-12 Speed limit**

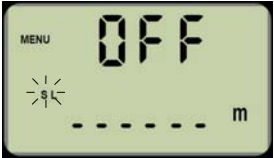
When measuring speeds, you can enter a desired speed limit into the instrument. With the speed limit feature turned on, the instrument signals a doubled high-pitched warble when a targeted vehicle exceeds that limit. The table below shows the procedure for turning on the speed limit feature and setting the speed limit.

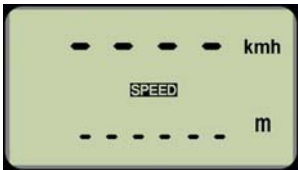
Action	Result
<p>1. Press <i>MENU / OPTIONS BUTTON</i> until the indicator SL begins to blink.</p> <p>The message in the upper display line indicates the status of the feature.</p>	 <p>The image shows a green LCD display with 'MENU' in the top left, 'OFF' in large digits in the center, a small icon of a speedometer with a starburst on the left, and 'm' on the right. Below the main display is a dashed line.</p>
<p>2. Toggle the speed limit feature by pressing and releasing the <i>SELECT / EDIT BUTTON</i>.</p>	 <p>The image shows a green LCD display with 'MENU' in the top left, 'On' in large digits in the center, 'kmh' on the right, and '65' in smaller digits below. A small icon of a speedometer with a starburst is on the left.</p>
<p>3. Press <i>SELECT / EDIT BUTTON</i> and hold it for approximately 2.5 seconds until the screen displays 000000 with the left-most digit flashing.</p>	 <p>The image shows a green LCD display with 'MENU' in the top left, '0n' in large digits in the center, 'kmh' on the right, and '000000' in smaller digits below. The first '0' is flashing. A small icon of a speedometer with a starburst is on the left.</p>
<p>4. The flashing digit that is ready to be edited. Use the following keys to enter the desired speed limit value :-</p> <ul style="list-style-type: none"> <li>• Press the <i>SELECT / EDIT BUTTON</i> to move one digit to the right. Press repeatedly to scroll through each digit.</li> <li>• Press <i>TEST / EDIT UP</i> or <i>BACKLIGHT / EDIT DN BUTTON</i> to make the adjustment.</li> <li>• Press <i>SELECT / EDIT BUTTON</i> to confirm the setting.</li> </ul>	
<p>5. Press <i>SPEED / OPTIONS BUTTON</i> to return to the speed measurement mode as shown in the right diagram. Press the <i>MENU / OPTIONS BUTTON</i> to go to the next menu option.</p>	 <p>The image shows a green LCD display with 'SPEED' in the center, 'kmh' on the right, and 'm' on the right below. There are dashed lines above and below the main display.</p>

**1-13 Basic speed measurement**

Use the sighting scope to aim to a target with a minimum distance of 15 meters (the minimum range of UltraLyte is 15 meters) and press the trigger twice. The first press turns on the scope aiming-dot and the second press takes the measurement. The instrument will begin a measurement after about three-quarters of a second.

2. When the instrument succeeds in taking a measurement, you experience three actions as follows :-

- (a) A high-pitched beep from the instrument.
- (b) The speed measurement projected onto the scope just below the aiming dot. (For this example, the speed is 0 or-0).
- (c) The screen displays the speed measurement and the distance as shown in the following diagram :-

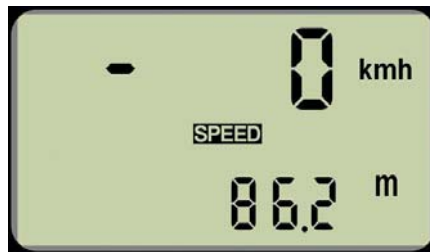

Diagram 10

**1-14 Muting the instrument**

When the instrument is taking readings, it normally makes a variety of audible signals to help inform you of its operational condition. If you prefer the instrument to be silent, you can mute the instrument with the following procedure :-

Action	Result
1. Press the <i>MENU / OPTIONS BUTTON</i> repeatedly until MUTE indicator blinks, and the screen shows Off or On.	
2. Press the <i>SELECT / EDIT BUTTON</i> to toggle the status of the mute feature.	

3. Press the *SPEED / OPTIONS BUTTON* to return to the speed measurement mode as shown in the right diagram. Press the *MENU / OPTIONS BUTTON* to go to the next menu option.

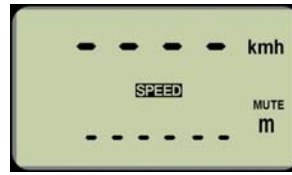

2. When the mute is on, LAS appears in the scope to let you know that laser is firing. Next, LAS and in-scope aiming disappear to let you know the measurement has completed, an indication similar to the high or low pitch tone in normal mode.

**1-15 Power conservation intervals**

The instrument has three timed power-off intervals to help conserve its batteries :-

Function	Interval	Effect of Time-out
In-scope numerical display	3 seconds	The numerical display shuts off.
In-scope aiming dot	20 seconds	Aiming dot shuts off.
Instrument	10 minutes (approximately)	Power shuts down.

2. Disabling the power-off intervals prevents the instrument from automatically shutting off; it must be manually turned off. Follow the following procedure to toggle the instrument's time-out feature :-

Action	Result
1. Press the <i>MENU / OPTIONS BUTTON</i> repeatedly until the ALL On indicator displays.	A digital display with 'MENU' in the top left corner. The main display shows 'OFF' in large digits, and below it, 'ALL On'.
2. Press <i>SELECT / EDIT BUTTON</i> to turn the time-out on/off.	A digital display with 'MENU' in the top left corner. The main display shows 'On' in large digits, and below it, 'ALL On'.
3. Press the <i>SPEED / OPTIONS BUTTON</i> to return to the speed measurement mode as shown in the right diagram. Press the <i>MENU / OPTIONS BUTTON</i> to go to the next menu option.	A digital display showing speed measurement mode. The top line shows dashes followed by 'kmh'. The middle line shows 'SPEED'. The bottom line shows dashes followed by 'm'.

**1-16 Precautions when using the instrument**

- (a) Avoid staring directly at the laser beam for prolonged periods.
- (b) Never attempt to view the sun through the scope. It may permanently damage your eyes.
- (c) Never point the instrument directly at the sun. Exposing the lens system to direct sunlight, even for a brief period, may permanently damage the laser transmitter.
- (d) Do not expose the instrument to temperatures below  $-30^{\circ}\text{C}$  or above  $60^{\circ}\text{C}$ .

**1-17 Maintenance**

Important notes :-

- (a) Operating temperature : The instrument is rated for a temperature range of  $-30^{\circ}\text{C}$  to  $60^{\circ}\text{C}$ .
- (b) Moisture and dust protection : This instrument is sealed to provide protection from normally encountered field conditions. It is protected from dust and from rain, and features temporary submersion resistance.
- (c) Shock protection : The UltraLyte is a precision instrument and should be handled with care. It should always be kept in a carrying case approved by the authorised agent when not in use. The instrument will withstand a reasonable drop shock. If you drop the instrument, check the scope alignment before using the instrument for measurement (see Chapter 2 for details).
- (d) Cleaning and storage : Take the following steps after each use and before returning the instrument to its case :-
  - (i) Wipe off excess moisture, and air-dry the instrument at room temperature.
  - (ii) If you won't be using the instrument again soon (say two weeks), remove the batteries before storing it.
- (e) Caring for the scope :-
  - (i) Do not put oil or lubricant on the scope. Do not use ordinary tissue paper to clean the lens, it will damage the lens.
  - (ii) The authorised agent will provide routine care for the scope.
- (f) Stop using the instrument if it does not function normally and report the matter to a supervisor for immediate arrangement to return it to the authorised agent for repair.

### 1-18 Checking the model number

You can check the instrument's model number and software revision level when you power-on. Start as you would if you were checking the display: press the trigger and keep it pressed. With the display segments all showing, press and hold the *SPEED / OPTIONS BUTTON* as you continue to hold down the trigger. That causes the screen to switch to a display as follows :-

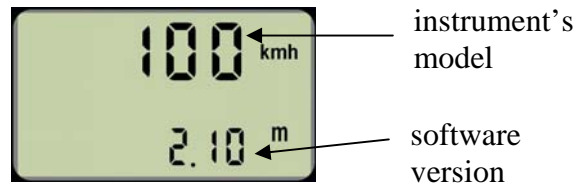

Diagram 11

### 1-19 Specifications

Specifications of 'UltraLyte 100 LR' laser gun are as follows :

- (a) Weight : 1.34 kg (about 3 lb);
- (b) Speed Accuracy :  $\pm 2$  km/h;
- (c) Minimum Range : 15 meters;
- (d) Maximum Range : 610 meters;
- (e) Speed Range :  $\pm 320$  km/h;
- (f) Range Accuracy :  $\pm 15$  cm (about 6 inches);
- (g) Temperature Range :  $-30^{\circ}\text{C}$  to  $60^{\circ}\text{C}$ ; and
- (h) Power : two C batteries providing up to 25 hours of operation.

\*\*\*\*\*

# **Chapter 2**

## **Guidelines on laser gun speed check operations**



## **Chapter 2**

### **Guidelines on laser gun speed check operations**

#### **2-01 Introduction**

This chapter sets out the guidelines for the use of the laser gun by police officers in speed check operations. The contents of the chapter cover the qualifications, roles and responsibilities of the Operator, the points to note when equipment is being collected, the checks to be carried out before and after the operation, the selection of the test location, the points to note and the records to be kept when an operation is being carried out. Officers should comply with the guidelines set out in this chapter to ensure the proper and safe use of the laser gun in speed detection. The annexes contain two record tables for reference.

#### **2-02 The roles and qualifications of officers**

The officers of the Regional Traffic Formations are responsible for carrying out laser gun speed check operations; roles include one Operator, one Assistant and at least one Reporting Officer. The Operator must be a holder of laser gun operator certificate issued by Traffic Branch Headquarters for a specified model of laser gun. The Assistant must be a qualified laser gun operator who will act as a corroborating officer. The Reporting Officer will be responsible for stopping the speeding vehicle and taking enforcement action.

#### **2-03 Points to note upon the collection of the laser gun and relevant equipment**

When collecting the laser gun, the Operator will collect it together with a tripod. He will immediately check the laser gun to see if there is any damage or defect, and inspect the accessories in the carrying case (e.g. battery and shoulder rest) to see if they are all available. After checking the equipment, the Operator will make an appropriate record in the specified register which is especially for that laser gun.

#### **2-04 Checks to be conducted before and after operation**

Before and after operation, the Operator will personally conduct the following 4 compulsory checks in sequence at the location specified by the SSP T (CIP E&C) in order to ensure that the laser gun is accurate and functioning normally: -

- (a) Instrument Self Test
- (b) Testing Display Integrity
- (c) Scope Alignment Test
- (d) Fixed Distance and Zero Velocity Check (to be checked using the tripod)

2. At the speed detection operation site, the Operator will conduct the above-mentioned (a) and (b) checks before and after the operation. He will also record the check results in 'Laser Gun Operator Record' (Annex 1) and in his police notebook. If an error message persists during the checks and cannot be rectified on the spot, the laser gun will be returned to the base for delivery to the authorised agent for repair. All the speeding-related tickets (if applicable) issued during the operation will be cancelled. For the procedures of cancellation, please refer to 2-04 of Part III of the Traffic Procedure Manual.

**2-05 Procedures for instrument checks**

The procedures for instrument checks are as follows : -

(a) Instrument Self Test

- (i) When the instrument is turned on, its microcontroller interrogates the system electronics. If all tests prove positive, the instrument displays dashes as follows; if there are any failures, an error message is displayed and the instrument will not operate.

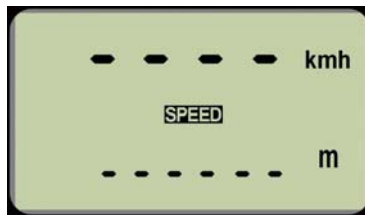

Diagram 12

- (ii) If the self-test indicates an error, check your power source. If the power source is not the problem, the instrument will be returned to the base and then to the authorised agent for checking.

(b) Testing Display Integrity

- (i) After the *TEST / EDIT UP BUTTON* is pressed, the screen will have the following displays : -

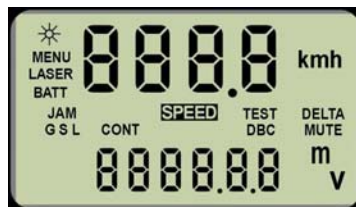

Diagram 13

Indicator	Feature Indicated	Explanation
*	Display Backlight	The display backlight is on.
MENU	Option menu	You are in the instrument's option menu.
LASER	Laser fire	The laser is firing.
BATT	Battery	Solid : you are in the battery test display. Blinking : the instrument's batteries are low.
kmh	Speed units	Speed unit (kmh = kilometers per hour)
JAM	Jam detection	Indicates a jamming signal.
GS	Gate - Short	Gate - Short : artificially restricts the minimum range of the instrument.
G L	Gate - Long	Gate - Long : artificially restricts the maximum range of the instrument.
SPEED	Speed mode	The instrument is taking speed measurement.
TEST	Test mode	The instrument is performing one of the several various self-tests.
CONT	Continuous mode	The instrument continuously acquires speed measurements while the trigger is held down (note : police will not use this function during law enforcement).
MUTE	Mute (silent) mode	The instrument indicator sounds have been turned off.
m	Distance unit	m = meters
V	Power unit	V = battery voltage

(ii) Press the *SELECT / EDIT BUTTON* to toggle the displays on and off. If you do not toggle off, the in-scope display times out after 5 seconds.

(iii) If any segment fails to display, the instrument will be returned to the base and then to the authorised agent for checking.

(c) Scope Alignment Test

This test is to ensure the accuracy of the scope system. The Operator will conduct the test at the location specified by SSP T (CIP E&C).

(i) Put the instrument in test tone mode. Press the *TEST / EDIT UP BUTTON* repeatedly until the display reads 'tt', which stands for test tone. When test tone mode is active, pressing the trigger generates an audible tone. The tone's pitch is related to the strength of the laser pulse returned to the instrument: a high tone indicates a strong return, a low tone indicates a weak one.

- (ii) Choose one or more prominent targets with definitive horizontal and vertical edges. Lampposts or top corners of a building are good choices. The targets' reflective qualities and distance from you should be such that you can clearly hear a change in the pitch of the test tone when you pan the instrument over the edges of the target. Make sure there is nothing behind the target the instrument might detect, so there is no doubt that any change in pitch is due strictly to the target.
- (iii) Press and hold the trigger while panning the instrument across the target. The tone changes pitch when the instrument acquires the target. The highest pitch - the 'on target' tone - should occur when the scope's red aiming dot is centered on the target. The laser gun must be tested for horizontal and vertical alignment. If the red dot in the scope is placed on the target and a low pitch tone is produced, the scope alignment is not correct and the instrument should not be used and must be returned to the base and then to the authorised agent for checking.

(d) Fixed distance and zero velocity check

To verify the accuracy and the measuring capability of the speed measurement of the instrument, this check must be conducted at the location specified by SSP T (CIP E&C). The ordinary range is 60 meters and the check must be conducted with a tripod. The procedures of the check are as follows: -

- (i) Aim the instrument at a fixed target and press the trigger once;
- (ii) observing the screen display, the speed reading should be '0 kmh';  
and
- (iii) the accuracy of the reading of the distance should be between '59.8' and '60.2'.

## **2-06 The selection of speed detection locations**

All speed detection locations must be approved by SSP T (SP E&C).

2. When there is an angle between the instrument's position and the target vehicle's direction of travel, the measured speed is less than the target's true speed. This phenomenon is known as the 'Cosine Effect'. The larger the angle, the lower the measured speed, this effect is always in the motorist's favour.

3. A good rule of thumb is not to exceed 1 meter off the road for every 10 meters shooting down the road to the target. The Operator should therefore assess the operation location in order to select an ideal position for an accurate speed measurement. Two examples are given below as a reference.

4. On a road with several lanes, the distance to the speed detection location has to be at least 10 times greater than the distance between the Operator's observation position and the mid-point of the traffic lane on the carriageway as shown in the following diagram :-

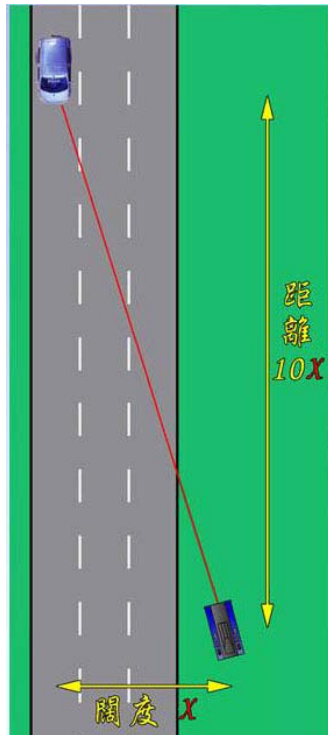

Diagram 14

5. When carrying out speed check operations from a bridge, the height above the carriageway should not exceed 10 meters. When carrying out such operations the target vehicle must be at a distance exceeding 100 meters from the Operator's observation position.

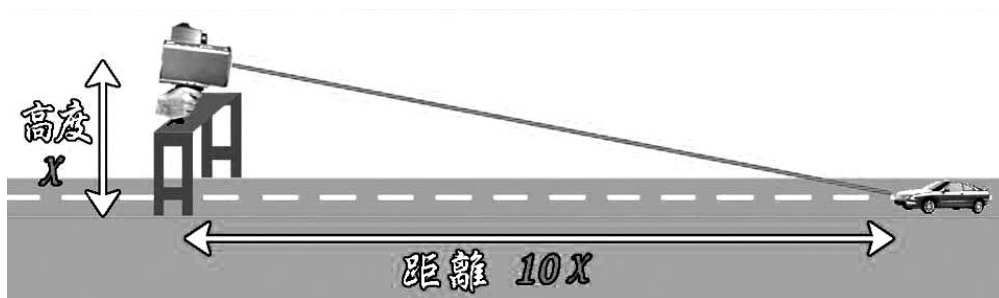

Diagram 15

6. The distance between the Operator and the target vehicle should not exceed 300 meters. Do not rely on the naked eye or the interval between lampposts to make estimations of distance. The distance measurement function of the laser gun should be used.

**2-07 Points to note during speed check operations**

While manning the operation, the Operator should take note of the following: -

- (a) Laser gun speed check operations should be carried out only when the road is free of any obstruction, oil stains, and other matter which may render the road surface unsafe for speed check operations.
- (b) Whenever it is practical to do so, the laser gun should be mounted on a tripod for operations.
- (c) The function of 'continuous speed detection' will not be used.

**2-08 Measuring the speed of a moving vehicle**

Measure the speed of a vehicle using the following procedure :-

- (a) The pressing of the trigger will activate the speed-reading mechanism. If the red dot of the scope is not lit before the trigger is pressed, the pressing of the trigger on that occasion will cause the lighting of the red dot only.
- (b) Aim the instrument at the registration plate area of the target vehicle and press the trigger. A low-pitched growl begins, indicating the instrument is trying to acquire a lock on the target.
- (c) Keep the trigger pressed and the instrument sighted on the target until you hear a beep. A double high-pitched beep means that a speed was captured; a low-pitched beep means a measurement error occurred.
- (d) The speed calculated for the target displays in the screen and in the scope. If the target vehicle was approaching, the speed displays a positive number; if the target was going away when it was measured, the speed displays a negative number.

**2-09 The JAM indicator**

The JAM indicator on the screen may blink during a measurement, accompanied by the jam tone indicating either one of two circumstances as follows: -

- (a) a strong light source such as headlights is being targeted; or
- (b) a targeted vehicle is employing a laser-jamming device.

2. Regardless of the level of interference, it will not produce an erroneous speed-reading. At a low level of interference, there will be a correct reading, even though the jam tone sounds and the indicator blinks. At a high level of interference, you will see the 'E07' error code.
3. The vehicle in question should be stopped when the instrument indicates strong interference. The Reporting Officer should investigate whether or not the vehicle driver/owner has committed any other offence.

## 2-10 Error conditions

Error conditions can occur in a measurement or in the system hardware. When the instrument detects an error condition, it displays an error code instead of a speed.

2. Measurement error conditions typically occur because the instrument could not acquire a target or could not maintain a 'lock' on the target. Usually this is caused by a target that is out of range, or by panning the instrument off the target during the measurement.
3. Most other error conditions are similarly trivial; correcting them requires only that you retry to take the measurement.

## 2-11 Error codes

The possible error indicators are listed and explained in the following table :-

Code	Explanation
doF	Display Overflow. The measurement exceeds the display capacity.
EoF	Editor Overflow.
E01	Measurement Error — target never acquired. The target was out of range or was too close.
E02	Measurement Error — Insufficient data. The instrument's view was obstructed or the target moved out of range.
E03	Measurement Error — Unstable targetting. Caused by poor aiming or by panning off the target.
E07	JAM Detect — Unable to acquire target due to strong light or jamming device.
E52	Temperature too hot. Stop operation.
E53	Temperature too cold. Stop operation.
E54, E55, E56, E60, E61, E62, E63	Calibration or memory failure. If the error persists, stop operation and return the instrument to the authorized agent for repair.

2. The Operator must immediately stop the speed check operation if the instrument displays error codes E54, E55, E56, E60, E61, E62 or E63. The Operator must clearly record such failure details in his police notebook and report the error to his supervisor.

## **2-12 Keeping records**

### The Operator

#### (a) Before the operation

- (i) Instrument checks – The Operator will conduct the laser gun checks himself, record the results in 'Laser Gun Operator Record' (Annex 1) and then sign the record which must be submitted to the designated Property Office after the operation and the information will be saved in CIS for record purposes. Please refer to the guidelines in paragraphs 2-04 and 2-05 of this chapter for the instrument checks.
- (ii) The Operator must ensure that the operation is conducted at an approved location in accordance with the guidelines in paragraph 2-06 of this chapter. In addition, where practicable, all distances indicated in his sketch (Annex 1) must be evaluated with the use of the laser gun.
- (iii) Records – A sketch of the site should be drawn on page 2 of 'Laser Gun Operator Record' and photographs to be taken by digital camera will be attached to ascertain the Operator's observation position and the speed detection location.

#### (b) During the operation

- (i) Vehicle particulars – Once the speed of a target speeding vehicle is displayed, the Operator will let the Assistant inspect the speed and the distance measured by the laser gun. At the same time, the Operator should tell the Assistant the particulars, the time of the speeding, the vehicle speed, the speed detection distance, the vehicle class, the vehicle registration number, the vehicle colour, the lane on which the target vehicle was travelling, so that the Assistant can make a contemporaneous record in 'Laser Gun Speed Detection Record' (Annex 2) and notify the Reporting Officer to stop the vehicle.
- (ii) Driver Request – Should the offending driver request to look at the speed detection location and the operating condition of the laser gun, the Reporting Officer, as far as practicable, should simply explain the operating procedures to him and then make an appropriate record of the incident in his police notebook. Any request to visit the Operator's observation location may be accommodated only when it is safe and practicable to do so.



- (c) After the operation
  - (i) Print the digital photograph on a piece of white paper, write down case reference number (RN), if any; location of the photograph; date and time of photograph; describe the content of the photograph; name and signature of the officer who took the photograph.
  - (ii) Verifying the records – At the conclusion of the operation, the Operator, the Assistant and the Reporting Officer should check all the entries written down in 'Laser Gun Speed Detection Record' against the particulars contained in Pol. 570 or Pol 287 (including the speed, the serial number of the 570/287, the contravention code, the vehicle particulars) to ensure that the particulars are consistent.
  - (iii) Signing in confirmation – The Operator and the Assistant should sign on each page of 'Laser Gun Speed Detection Record' for confirmation.
  - (iv) The Operator will submit the duly signed 'Laser Gun Operator Record', 'Laser Gun Speed Detection Record' and the printout and explanation of the digital photograph to the Property Office and file a record in CIS accordingly.

## 2. The Assistant

- (a) During the operation
  - (i) Vehicle particulars – After the speed of the target speeding vehicle has been displayed, the Assistant must inspect the readings of the speed and the distance displayed on the laser gun as corroborating evidence. He will make a contemporaneous record of the following particulars; the time, the vehicle speed, the speed detecting distance, the class of vehicle, the vehicle registration number, the colour and the lane when the target vehicle was travelling, on 'Laser Gun Speed Detection Record' (Annex 2). He will also inform the Reporting Officer to stop the target vehicle.
  - (ii) Penalty ticket particulars – The Assistant is required to write down the relevant Pol. 570 serial number, the contravention code and the U.I. number of the Reporting Officer on 'Laser Gun Speed Detection Record' forthwith as a formal record.

## (b) After the operation

- (i) Verifying record – At the conclusion of the operation, the Assistant will check with the Operator and the Reporting Officer whether the entries on the 'Laser Gun Speed Detection Record' and the entries on each Pol. 570 and Pol. 287 (including the speed, the serial number of 570/287, the contravention code and the vehicle particulars) issued are consistent.
- (ii) Signing in confirmation – Both the Assistant and the Operator will sign in confirmation on each page of 'Laser Gun Speed Detection Record' before the Operator submits it to the Property Office and inputs the data into CIS.
- (iii) Making a formal record – Make an appropriate record in his police notebook.

3. The Reporting Officer : Having been informed by the Assistant, the Reporting Officer is responsible for stopping the vehicle and issuing Pol 570 or Pol 287.

4. Supervising officers will ensure the following during a speed check operation :-

- (a) that all officers have received relevant training;
- (b) that every officer fully understands his role and responsibilities;
- (c) that the testing and handling of equipment by the Operator is in accordance with his training;
- (d) that the road is free of any obstruction, oil stains other matter which may render the road surface unsafe for a speed check operation; and
- (e) that all records and notebook entries for the operation are properly completed and where appropriate, signed by the respective officers.

### **2-13 Making a record in police notebook**

All particulars relating to the speed check operation should be appropriately recorded according to the provisions stipulated in PGO and FPM Chapter 53.

\*\*\*\*\*

## **Chapter 3**

# **Testing facilities within Traffic Regions and responsibilities of the management**

### Chapter 3

#### Testing facilities within Traffic Regions and responsibilities of the management

##### 3-01 Introduction

This chapter states the responsibilities of SSP T on testing facilities, choosing operation locations and monitoring speed check operations.

##### 3-02 Laser gun basic testing facilities within Traffic Regions

SSP T (CIP E&C) has to set up one or more of the following facilities and photograph the designated testing facilities as a formal record :-

(a) Fixed Distance & Zero Velocity Check

A distance of 60 meters from the shooting mark will be set up either in the Traffic Region Operational Base or other suitable police premises to carry out the test. Traffic Regions can seek help from the Lands Department's Survey and Mapping Office to set up a 60-meter distance from the shooting mark and an appropriate target.

(b) Scope Alignment Test

Choose one or more prominent targets with definitive horizontal and vertical edges. Lampposts or top corners of a building are good choices. The targets' reflective qualities and distance from you should be such that you can clearly hear a change in the pitch of the test tone when you pan the instrument over the edges of the target. Make sure there is nothing behind the target the instrument might detect, so there is no doubt that any change in pitch is due strictly to the target.

##### 3-03 Traffic Regions choosing locations for speed check operations

Other than observing the requirements illustrated in paragraph 2-06 of these notes, SSP T (SP E&C) has to consider the following factors when they choose the locations for speed check operations :-

- (a) the locations for speed check operations have fulfilled the Occupational Safety and Health requirements ; and
- (b) the designated stopping locations will not create factors that may cause an accident.

### **3-04 Responsibilities of management**

SSP T will ensure that supervisory officers at the rank of Station Sergeant or above routinely carry out inspections on speed check operations, to make sure that the laser gun Operators, Assistants and Reporting Officers have performed their duties correctly and professionally. After inspections, supervisory officers will make an appropriate written record.

### **3-05 Proper storage of the laser gun**

SSP T (CIP E&C) will designate locations in their Region to store the laser guns properly. The location will fulfill the following requirements :-

- (a) with appropriate security measures to ensure that the laser gun will not be tampered with; and
- (b) the issuing and returning of the laser gun must be recorded in a specified register which has to be signed and verified by the laser gun Operator and his supervisors.

\*\*\*\*\*

LC Paper No. CB(1)1125/07-08(04)  
 UltraLyte 鐳射槍操作員記錄表(由操作員填寫)  
 UltraLyte Laser Gun Operator Record (for Operator's use)

第一部份：測試記錄 Part 1: Test Record

鐳射槍編號 Laser Gun Serial Number : \_\_\_\_\_

1. 行動前在基地測試 Testing at the base before operation	日期 Date:	時間 Time:
儀器自行測試 <input type="checkbox"/> 妥當 (Instrument Self Test) Correct	測試地點 Testing location:	
完整版面展示測試 <input type="checkbox"/> 妥當 (Testing Display Integrity) Correct	_____	
平排敲擊效應測試 (Scope Alignment Test)	目標物 Target: _____	<input type="checkbox"/> 水平測試妥當 Horizontal Check Correct
	距離 Distance: _____	<input type="checkbox"/> 垂直測試妥當 Vertical Check Correct
定距零速測試 (Fixed Distance & Zero Velocity Check)	讀數 Readings: _____ km/h; _____ m	

2. 偵速現場行動前測試 Testing at the scene before operation	日期 Date:	時間 Time:
儀器自行測試 <input type="checkbox"/> 妥當 (Instrument Self Test) Correct	測試地點 Testing location:	
完整版面展示測試 <input type="checkbox"/> 妥當 (Testing Display Integrity) Correct	_____	

3. 偵速現場行動後測試 Testing at the scene after operation	日期 Date:	時間 Time:
儀器自行測試 <input type="checkbox"/> 妥當 (Instrument Self Test) Correct	測試地點 Testing location:	
完整版面展示測試 <input type="checkbox"/> 妥當 (Testing Display Integrity) Correct	_____	

4. 行動後在基地測試 Testing at the base after operation	日期 Date:	時間 Time:
儀器自行測試 <input type="checkbox"/> 妥當 (Instrument Self Test) Correct	測試地點 Testing location:	
完整版面展示測試 <input type="checkbox"/> 妥當 (Testing Display Integrity) Correct	_____	
平排敲擊效應測試 (Scope Alignment Test)	目標物 Target: _____	<input type="checkbox"/> 水平測試妥當 Horizontal Check Correct
	距離 Distance: _____	<input type="checkbox"/> 垂直測試妥當 Vertical Check Correct
定距零速測試 (Fixed Distance & Zero Velocity Check)	讀數 Readings: _____ km/h; _____ m	

操作員姓名 Name of Operator : \_\_\_\_\_

階級及編號 Rank & UI : \_\_\_\_\_

簽署 Signature : \_\_\_\_\_

第二部份: 草圖 (請清楚標明操作員觀察地點及偵速地點)

Part 2: Sketch (please mark clearly the observation post of operator and the speed detection location)

操作員姓名 Name of Operator : \_\_\_\_\_

階級及編號 Rank & UI : \_\_\_\_\_

簽署 Signature : \_\_\_\_\_

鐳射槍偵速記錄表(由助手填寫)  
Laser Gun Speed Detection Record (for Assistant's use)

LC Paper No. CB(1)1125/07-08(04)

日期 Date : \_\_\_\_\_ 行動時間 Operation time : 由 From \_\_\_\_\_ 時至 hours to \_\_\_\_\_ 時 hours

操作員觀察地點 Operator's observation position : \_\_\_\_\_

偵速地點(違例) Speed detection location (offence location) : \_\_\_\_\_

操作員觀察地點與偵速地點距離約 Distance between operator's observation position and speed detection location (approximately) \_\_\_\_\_ 米 m

車輛目標位置 Targeted at vehicle's : \*車頭 front / 車尾 rear

偵速地點(違例)路面情況 Road Surface situation of the speed detection location (offence location) : \*平路 flat / 上斜 uphill / 落斜 downhill / 彎路 bend / 天橋 flyover /

架空道路 elevated road / 上 up / 落 down 天橋 flyover

天氣情況 Weather situation : \*晴朗 fine / 陰天 cloudy

交通流量 Traffic flow : \*疏落 light / 普通 medium / 繁忙 heavy

鐳射槍型號及機身編號 Laser gun model and S/No. : \_\_\_\_\_ 鐳射槍操作員 Laser gun operator : \_\_\_\_\_

路面時速限制 Speed limit of the road : \_\_\_\_\_ km/h 最近速度限制標誌位置 Location of nearest speed limit sign : \_\_\_\_\_

截車地點 Stopping location : \_\_\_\_\_

編號 S/N	時間 Time	車速 Speed (km/h)		偵速距離 Speed Detection Distance (m)	車輛 Vehicle		車身顏色 Vehicle Colour		目標車行車線 Lane of Target Vehicle	票控人員 Issuing Officer	Pol 570 No. (Pol 287 No./ RN No.)	違例 事項 Code
		量度所得 Measured	寬減後 Minus Technical Allowance		類別 Class	車牌 Registration Mark	肉眼所見 Visible	行車證記錄 Recorded on Licence Disc				
1.												
2.												
3.												

(倘此頁不敷應用，請用附加頁記錄同一偵速行動中違例的車輛資料。Use additional page to record details of the offending vehicles if spaces in this page is not enough.)

助手姓名 Name of Assistant : \_\_\_\_\_

操作員姓名 Name of Operator : \_\_\_\_\_

階級及編號 Rank & UI : \_\_\_\_\_

階級及編號 Rank & UI : \_\_\_\_\_

簽署 Signature : \_\_\_\_\_

簽署 Signature : \_\_\_\_\_

R = 紅 Red      P = 紫 Purple      BR = 啡 Brown      Y = 黃 Yellow      B = 米黃 Beige      BL = 藍 Blue      G = 綠 Green      S = 銀 Silver  
 BK = 黑 Black      M = 多種 Multiple      O = 橙 Orange      PK = 粉紅 Pink      W = 白 White      GD = 金 Gold      GY = 灰 Grey

\*刪除不適用者 Delete as appropriate



編號 S/N	時間 Time	車速 Speed (km/h)		偵速距離 Speed Detection Distance (m)	車輛 Vehicle		車身顏色 Vehicle Colour		目標車行車線 Lane of Target Vehicle	票控人員 Issuing Officer	Pol 570 No. (Pol 287 No./ RN No.)		違例 事項 Code
		量度所得 Measured	寬減後 Minus Technical Allowance		類別 Class	車牌 Registration Mark	肉眼所見 Visible	行車證記錄 Recorded on Licence Disc					

助手姓名 Name of Assistant : \_\_\_\_\_

操作員姓名 Name of Operator : \_\_\_\_\_

階級及編號 Rank & UI : \_\_\_\_\_

階級及編號 Rank & UI : \_\_\_\_\_

簽署 Signature : \_\_\_\_\_

簽署 Signature : \_\_\_\_\_

- R = 紅 Red      P = 紫 Purple      BR = 啡 Brown      Y = 黃 Yellow      B = 米黃 Beige      BL = 藍 Blue      G = 綠 Green      S = 銀 Silver  
 BK = 黑 Black      M = 多種 Multiple      O = 橙 Orange      PK = 粉紅 Pink      W = 白 White      GD = 金 Gold      GY = 灰 Grey

Operator Checklist

The workflow of the Operator during a laser gun speed check operation is as follows: -

1. Collect a laser gun and a tripod from the store designated by SSP T (CIP E&C) and make a proper entry in the specified register and police notebook.
2. After collecting the laser gun, conduct the following four system checks at the location designated by SSP T (CIP E&C). The results of the checks must be recorded properly in the Operator's police notebook and 'Laser Gun Operator Record' (Annex 1). If the laser gun fails any one of the tests, it cannot be used in a speed check operation.
  - (a) Instrument Self Test
  - (b) Testing Display Integrity
  - (c) Scope Alignment Test
  - (d) Fixed Distance & Zero Velocity Check.
3. Transport the laser gun to the speed check location, test the laser gun on the foregoing tests (a) and (b) for the second time before commencing the speed check operation. Record the results of the tests in the Operator's police notebook and 'Laser Gun Operator Record'. If the laser gun fails any one of the tests, it cannot be used in a speed check operation.
4. Draw a sketch of the speed check location on page 2 of 'Laser Gun Operator Record' and take digital photographs to show the Operator's observation position and the speed detection location.
5. On completion of the speed check operation, at the scene, test the laser gun on the foregoing tests (a) and (b) for the third time. Record the results of the tests in the Operator's police notebook and 'Laser Gun Operator Record'. If the laser gun fails any one of the tests, the speeding tickets and summons issued during the operation will be cancelled.
6. If at any time during the speed check operation, the laser gun malfunctions or displays error codes E54, E55, E56, E60, E61, E62, E63 the speed check operation must be stopped. The operator must immediately inform his supervisor. All speeding tickets and summons issued during the operation will be cancelled.
7. Upon return to the base having completed all speed check operations, conduct the four system checks at the location designated by SSP T (CIP E&C). Record the results of the tests in the Operator's police notebook and 'Laser Gun Operator Record'. If the laser gun fails any one of the tests, the speeding tickets and summons issued during the operation will be cancelled.
8. The Operator will return the laser gun to the designated store and make a proper entry in the specified register and the police notebook.
9. In consultation with the Assistant and Reporting Officer, check all the entries written down in 'Laser Gun Speed Detection Record' (Annex 2) against the particulars contained in Pol 570 or Pol 287 to ensure that the particulars are consistent. The Operator and the Assistant will sign on each page of the 'Laser Gun Speed Detection Record' for confirmation.
10. Submit the duly signed 'Laser Gun Operator Record', 'Laser Gun Speed Detection Record' and the printout of the digital photograph and the explanation to the Property Office and file a record in CIS accordingly.