



街頭設計聯盟

STREET DESIGN UNIT

專業設計師及建築師組成

11/4/2012

1

願景

分析排檔生態
市集文化產業

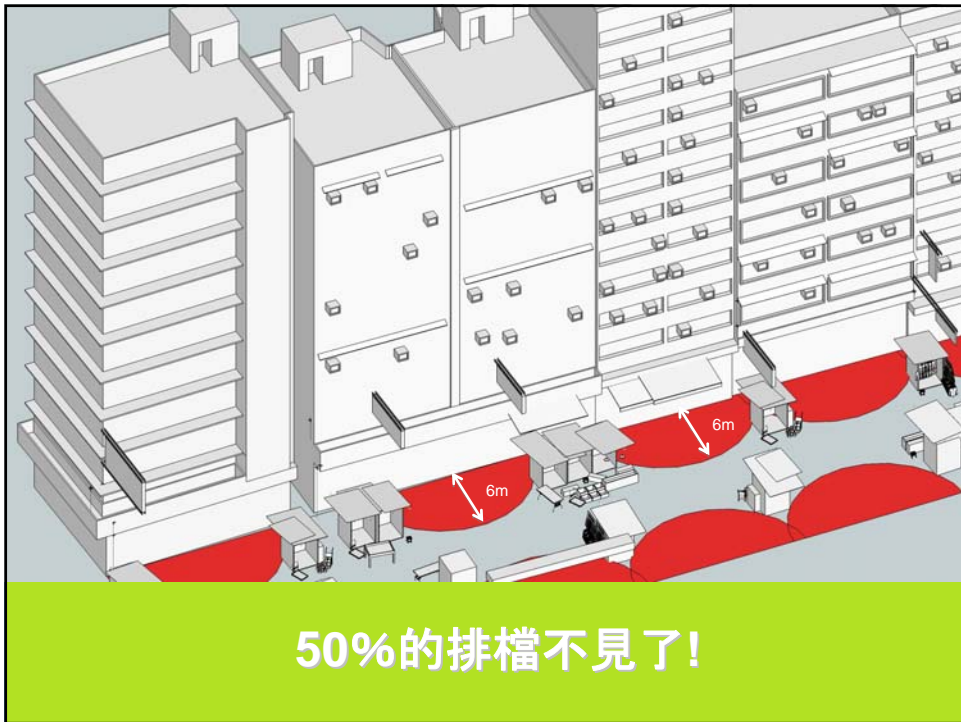

2 小販生計

3尺X4尺空間的問題



現在

- 70年代法例
- 不合時宜



理想

- 合理經營空間
- 足以維生

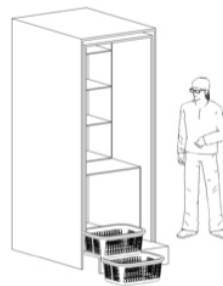
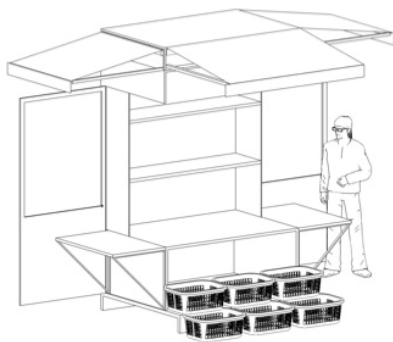
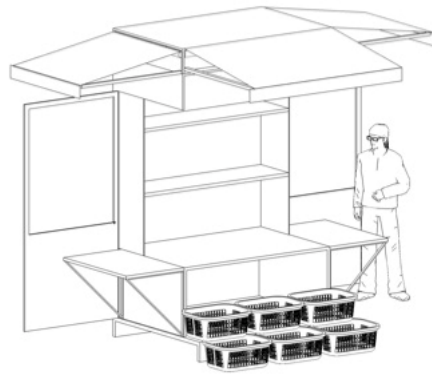

50%的空間不見了!

3 軟文化力量展現

本土特色 . 文化旅遊 . 文化承傳 . 產業更新



3 軟文化力量展現

保育旅遊 . 香港特色 . 排檔改善 . 參與式設計!!





案例
台北饒河街



案例
台北饒河街



案例

CHATUCHUAK MARKET, BANGKOK



案例

CHATUCHUAK MARKET, BANGKOK

4

總結

文化旅遊/文化承傳/產業更新

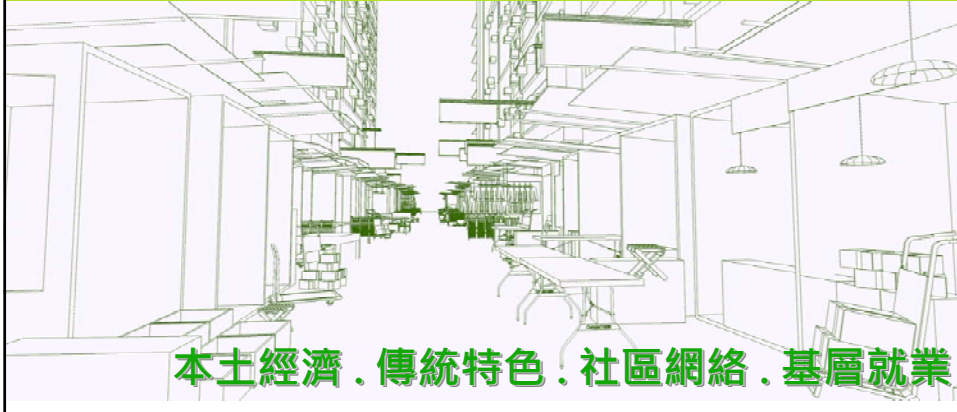

本土經濟 . 傳統特色 . 社區網絡 . 基層就業



街頭設計聯盟
Street Design Union

謝謝!