

IMPORTANT

1. The Guidelines come into operation on 27 June 2016. Subject to any subsequent revision, they apply to all Legislative Council general elections and by-elections conducted under the Legislative Council Ordinance (Cap 542) to be held after publication.
2. The law stated in these Guidelines is that prevailing as at the date of publication.
3. All specified forms referred to in these Guidelines are obtainable from the Registration and Electoral Office (tel: 2891 1001; fax: 2891 1180; e-mail: reoenq@reo.gov.hk) and its website at <http://www.reo.gov.hk>.
4. Electioneering, campaigning and canvassing activities referred to in these Guidelines include any positive and negative campaigning conducted for the purpose of promoting or prejudicing the election of a candidate or candidates at the election.
5. In the event that future amendments to these Guidelines are necessary, the updated Guidelines will be made available at the website of the Electoral Affairs Commission at <http://www.eac.gov.hk>.

2016 LEGISLATIVE COUNCIL GENERAL ELECTION

Key Information

- (1) Polling Date : 4 September 2016
- (2) Polling Hours : 7:30 am to 10:30 pm
- (3) Period to submit Application for Nominations Advisory Committee's Service by Prospective Candidates : 6 May to 15 July 2016
- (4) Nomination Period of Candidature : 16 to 29 July 2016
- (5) Period to submit Request for Printing of Particulars Relating to Candidates on Ballot Papers by Candidates : 16 to 29 July 2016
- (6) Chairman's Briefing for Candidates : 2 August 2016
- (7) Maximum Amount of Election Expenses : Please refer to paragraph 16.10 of the Guidelines.
- (8) Deadline to remove all Election Advertisements on display : Not later than 14 September 2016
- (9) Submission of Return and Declaration of Election Expenses and Election Donations by Candidates : Not later than 8 November 2016*
(including contested and uncontested candidates)

- (10) Submission of Claim for Financial Assistance by Candidates : Not later than 8 November 2016*
(including contested and uncontested candidates)
- (11) Deadline to lodge Election Petition : Not later than 9 November 2016*
(if uncontested, not later than 5 October 2016[%])

* Assuming that the election result is published in the Gazette on 9 September 2016

% Assuming that the election result is published in the Gazette on 5 August 2016

ABBREVIATIONS

AR, ARs	authorised representative, authorised representatives
ARO, AROs	Assistant Returning Officer, Assistant Returning Officers
BO	Buildings Ordinance (Cap 123)
Cap	Chapter of the Laws of Hong Kong
CAS	Civil Aid Service
CE	Chief Executive
CEEEO	Chief Executive Election Ordinance (Cap 569)
CEO	Chief Electoral Officer
CRO	Chief Returning Officer
CFA	Court of Final Appeal
CFI	Court of First Instance
CSD	Correctional Services Department
DAS	Director of Accounting Services
DC	District Council
DC (first) FC	District Council (first) functional constituency
DC (second) FC	District Council (second) functional constituency
DCO	District Councils Ordinance (Cap 547)

DLO, DLOs	District Lands Office, District Lands Offices
DO, DOs	District Office, District Offices
EA, EAs	election advertisement, election advertisements
EAC or the Commission	Electoral Affairs Commission
EAC (EP) (LC) Reg	Electoral Affairs Commission (Electoral Procedure) (Legislative Council) Regulation (Cap 541D)
EAC (FA) (APP) Reg	Electoral Affairs Commission (Financial Assistance for Legislative Council Elections and District Council Elections) (Application and Payment Procedure) Regulation (Cap 541N)
EAC (NAC) (LC) Reg	Electoral Affairs Commission (Nominations Advisory Committees (Legislative Council)) Regulation (Cap 541C)
EAC (ROE) (FCSEC) Reg	Electoral Affairs Commission (Registration) (Electors for Legislative Council Functional Constituencies) (Voters for Election Committee Subsectors) (Members of Election Committee) Regulation (Cap 541B)
EAC (ROE) (GC) Reg	Electoral Affairs Commission (Registration of Electors) (Legislative Council Geographical Constituencies) (District Council Constituencies) Regulation (Cap 541A)
EACO	Electoral Affairs Commission Ordinance (Cap 541)
EC	Election Committee

ECICO	Elections (Corrupt and Illegal Conduct) Ordinance (Cap 554)
election	general election or by-election as appropriate
election return	return and declaration of election expenses and election donations
ERO	Electoral Registration Officer
FC, FCs	functional constituency, functional constituencies
GC, GCs	geographical constituency, geographical constituencies
HKICPA	Hong Kong Institute of Certified Public Accountants
HKSAR	Hong Kong Special Administrative Region
ICAC	Independent Commission Against Corruption
LC Subscribers & Deposit Reg	Legislative Council (Subscribers and Election Deposit for Nomination) Regulation (Cap 542C)
LCO	Legislative Council Ordinance (Cap 542)
LegCo	Legislative Council
MAC, MACs	Mutual Aid Committee, Mutual Aid Committees
NAC, NACs	Nominations Advisory Committee, Nominations Advisory Committees
NCZ	no canvassing zone

NSZ	no staying zone
OPCPD	the Office of the Privacy Commissioner for Personal Data
OVIES	Online Voter Information Enquiry System
para., paras.	paragraph, paragraphs
PCBP (LC & DC) Reg	Particulars Relating to Candidates on Ballot Papers (Legislative Council and District Councils) Regulation (Cap 541M)
PD (P) O	Personal Data (Privacy) Ordinance (Cap 486)
PHMSO	Public Health and Municipal Services Ordinance (Cap 132)
POBO	Prevention of Bribery Ordinance (Cap 201)
POO	Public Order Ordinance (Cap 245)
PRO, PROs	Presiding Officer, Presiding Officers
REO	Registration and Electoral Office
RO, ROs	Returning Officer, Returning Officers
RR	Rural Representative
RREO	Rural Representative Election Ordinance (Cap 576)
RTO	Road Traffic Ordinance (Cap 374)
S, s, Ss, ss	section, sections

SFC, SFCs

special functional constituency,
special functional constituencies

TD

Transport Department

CONTENTS

	<u>Page</u>
CHAPTER 1 INTRODUCTION	1
Part I : The Legislative Council	1
Part II : The Guidelines	6
Part III : Sanction	7
 CHAPTER 2 GEOGRAPHICAL CONSTITUENCIES	 9
Part I : Description	9
Part II : Registration of Electors	9
Part III : The Voting System for Geographical Constituencies	19
 CHAPTER 3 FUNCTIONAL CONSTITUENCIES	 25
Part I : Composition	25
Part II : Registration of Electors	25
Part III : The Voting Systems for Functional Constituencies	37
 CHAPTER 4 NOMINATION OF CANDIDATES	 42
Part I : Eligibility and Disqualification for Nomination	42
Part II : Nominations Advisory Committees	47
Part III : When and How to Nominate	50

Part IV	: Election Deposit	57
Part V	: Validity of Nominations	59
Part VI	: Withdrawal of Candidature	63
Part VII	: Notice of Valid Nominations	63
Part VIII	: Particulars Relating to Candidates on Ballot Papers	64
Part IX	: Candidates' Briefing and Introduction to Candidates	72
CHAPTER 5	POLLING AND COUNTING ARRANGEMENTS	75
Part I	: Before the Poll	75
Part II	: Outside the Polling Station	80
Part III	: Commencement of Polling	82
Part IV	: Admission to the Polling Station	84
Part V	: Conduct inside the Polling Station	88
Part VI	: Close of Poll	100
Part VII	: Sorting of Ballot Papers	104
Part VIII	: The Count	109
Part IX	: Declaration of Result	131
Part X	: Disposal of Documents	132
CHAPTER 6	ELECTION PETITIONS	134
Part I	: Grounds for Lodging an Election Petition	134

Part II	: Who could, and When to, Lodge Election Petitions	135
CHAPTER 7	APPOINTMENT AND ROLES OF ELECTION AGENT, ELECTION EXPENSE AGENTS, POLLING AGENTS AND COUNTING AGENTS	137
Part I	: General	137
Part II	: Types and Numbers of Agents	137
Part III	: Qualifications of Agents	138
Part IV	: Civil Servants Acting as Agents	139
Part V	: Election Agent	139
Part VI	: Election Expense Agents	144
Part VII	: Polling Agents	148
Part VIII	: Counting Agents	162
CHAPTER 8	ELECTION ADVERTISEMENTS	168
Part I	: What Constitutes an Election Advertisement	168
Part II	: Period and Area of Display	175
Part III	: Allocation of Designated Spots	181
Part IV	: Conditions and Limitations on Display	184
Part V	: Application for Temporary Occupation of Government Land at Public Place for Holding Electioneering Activities	187

Part VI	Requirements relating to Publication of Election Advertisements	188
Part VII	: Requirements relating to Printed Election Materials	192
Part VIII	: Non-Compliance and Consequences	193
Part IX	: Advertisements of Political, Professional/Trade Bodies or Other Organisations	195
Part X	: Free Postage for Election Advertisements	197
Part XI	: Election Advertisements for Registered Electors and Authorised Representatives in the Custody of CSD and Other Law Enforcement Agencies	207
CHAPTER 9	ELECTIONEERING ACTIVITIES AT PREMISES OR BUILDINGS WHERE ELECTORS RESIDE, WORK OR FREQUENT	209
Part I	: General	209
Part II	: Rights of Tenants and Owners	210
Part III	: Guidelines to be Observed by Candidates in the Conduct of Electioneering Activities	212
Part IV	: Guidelines to be Observed by Owners, Management and Organisations for Handling Applications for Conduct of Electioneering Activities on the Premises within their Jurisdiction	218
Part V	: Conduct of Electioneering Activities in Premises under the Management of Housing Department and Hong Kong Housing Society	225
Part VI	: Sanction	225

CHAPTER 10	ELECTION MEETINGS	227
Part I	: General	227
Part II	: Election Meetings in Public Places	228
Part III	: Election Meetings at Private Premises	235
Part IV	: Electioneering Exhibitions	235
Part V	: Fund Raising Activities at Election Meetings	236
CHAPTER 11	ELECTION BROADCASTING, MEDIA REPORTING AND ELECTION FORUMS	237
Part I	: General	237
Part II	: Electioneering on Television and Radio	237
Part III	: Advertising through the Print Media	243
Part IV	: Election Forums	245
Part V	: Sanction	246
CHAPTER 12	USE OF SOUND AMPLIFYING DEVICE AND VEHICLES	248
Part I	: General	248
Part II	: Use of Loudspeakers and Vehicles	248
Part III	: Sanction	252

CHAPTER 13	ELECTIONEERING ACTIVITIES CONDUCTED IN SCHOOLS OR PARTICIPATED BY SCHOOL PUPILS	253
Part I	: General	253
Part II	: School Pupils	253
Part III	: Electioneering Activities in Schools	255
Part IV	: Sanction	256
CHAPTER 14	PROHIBITION AGAINST CANVASSING ACTIVITIES OUTSIDE POLLING STATIONS	257
Part I	: General	257
Part II	: Determination of No Canvassing Zone and No Staying Zone	257
Part III	: Conduct inside the No Canvassing Zone and No Staying Zone	259
Part IV	: Penalty	262
CHAPTER 15	EXIT POLL	263
Part I	: General	263
Part II	: Secrecy of the Vote	263
Part III	: Conduct of Exit Polls	264
Part IV	: Identification of Interviewers	267
Part V	: Sanction	267

CHAPTER 16	ELECTION EXPENSES AND ELECTION DONATIONS	269
Part I	: What constitutes Election Expenses	269
Part II	: Who may incur Election Expenses and their Limit	272
Part III	: Election Donations	275
Part IV	: Return and Declaration of Election Expenses and Election Donations	278
Part V	: Advance Return of Election Donations	283
Part VI	: Financial Assistance	284
Part VII	: Special Features Applicable to the List of Candidates in a Geographical Constituency and the District Council (second) Functional Constituency Election	290
Part VIII	: Enforcement and Penalty	293
CHAPTER 17	CORRUPT AND ILLEGAL CONDUCT	296
Part I	: General	296
Part II	: Corrupt Conduct relating to Nomination and Withdrawal of Candidature	297
Part III	: Illegal Conduct relating to Electioneering	298
Part IV	: Corrupt Conduct relating to Electioneering and Voting	302
Part V	: Corrupt and Illegal Conduct relating to Election Expenses and Election Donations	304
Part VI	: Power of Court to Excuse Innocent Acts	305
Part VII	: Non-Compliance with the Law and Sanction	306

CHAPTER 18	NAMEDROPPING	308
CHAPTER 19	PARTICIPATION IN ELECTION-RELATED ACTIVITIES BY CIVIL SERVANTS AND OFFICIALS UNDER THE POLITICAL APPOINTMENT SYSTEM AND ATTENDANCE OF PUBLIC FUNCTIONS BY BOTH CIVIL SERVANTS AND CANDIDATES	315
Part I	: General	315
Part II	: Participation in Electioneering Activities by Civil Servants	316
Part III	: Attendance of Public Functions by Civil Servants	317
Part IV	: Attendance of Public Functions by Candidates	318
Part V	: Officials Under the Political Appointment System	319
CHAPTER 20	COMPLAINTS PROCEDURE	320
Part I	: General	320
Part II	: To Whom a Complaint may be Made	320
Part III	: Time and Procedure for Making Complaint	321
Part IV	: Complaints inside a Polling Station	322
Part V	: The Processing of Complaint	323
Part VI	: Electoral Affairs Commission's Report on Complaints	325

Part VII : Obligations of the Returning Officer, the Presiding Officer and the Chief Electoral Officer 325

Part VIII : Sanction for False Complaint 326

APPENDICES

Appendix A : Legislative Council Election Action Checklist for Candidates 327

Appendix B : The Functional Constituencies and their Electors 347

Appendix C : The Preferential Elimination System of Voting (applicable to the election of the 4 Special Functional Constituencies) - How Votes are Counted (with Annex showing Working Examples) 372

Appendix D : The Combined Polling Arrangements - Polling Stations for Various Kinds of Electors in the General Election 380

Appendix E : Submission Method, Formats and Standard on Posting Electronic Copy of Election Advertisement and Relevant Information/Documents onto an Open Platform for Public Inspection (with Annexes I and II on the guidelines and basic layout design requirements for Candidate's Platform) 384

Appendix F : Methods of Folding of Election Mail 392

Appendix G : Canvassing Activities which are Forbidden Within a No Canvassing Zone 394

Appendix H : Conduct of Electioneering Activities and Election Meetings in Premises under the Management of the Housing Department and the Hong Kong Housing Society 396

Appendix I : Guidance on Electioneering Activities 397

Appendix J	: Complaint Cases Provided by Office of the Privacy Commissioner for Personal Data (“OPCPD”)	400
Appendix K	: Guidance Note on Safe Conduct of Election-related Activities	402
Appendix L	: Application for a Permit under S 4(17) of Summary Offences Ordinance, Cap 228 for Non-Charitable Purposes – Administrative Guidelines and Licensing Conditions for the issue of Public Fund-raising Permits for Non-Charitable Purposes	404
Appendix M	: Observations made by the Court in an Election Petition relating to a TV Programme on 2010 Legislative Council By-election	412
Appendix N	: Fair and Equal Treatment of Candidates by the Print Media	413
Appendix O	: Application Procedure for the Approval of Float Design	414
Appendix P	: Observations made by the Court of Final Appeal in a case touching upon Election Expenses (FACV No. 2 of 2012)	416
Appendix Q	: Items of Expenses which may be Counted towards Election Expenses	417
Appendix R	: Collection of Election Donations	420
Appendix S	: Guidelines for Mutual Aid Committees Participating in Electioneering Activities	421
Appendix T	: Guidelines for Candidates on Sending Election Advertisements to Registered Electors and Authorised Representatives in the Custody of the Correctional Services Department	422
INDEX		425

CHAPTER 1

INTRODUCTION

PART I : THE LEGISLATIVE COUNCIL

1.1 The Legislative Council (“LegCo”) of the Hong Kong Special Administrative Region (“HKSAR”) is constituted under the Legislative Council Ordinance (Cap 542) (“LCO”) for the purpose of enacting laws, examining and approving budgets, taxation and public expenditure, receiving and debating the policy addresses of the Chief Executive (“CE”), raising questions on the work of the Government, debating issues concerning public interests and handling complaints from Hong Kong residents, etc.

1.2 In accordance with the Basic Law and the LCO, the term of office of the LegCo is 4 years except the first term which was 2 years. Each term of its office is to begin on a date to be specified by the CE in Council. The first term LegCo was between 24 May 1998 and 30 June 2000. The second, third, fourth and fifth term of LegCo began on 1 October 2000, 1 October 2004, 1 October 2008 and 1 October 2012 respectively. The sixth term will begin on 1 October 2016. Each term is for 4 years. The CE must specify a date for holding a general election to elect the members for each term of office of the LegCo. A person returned as a member at a general election holds office from the beginning of the term of office of the LegCo next following the election and vacates office at the end of the term. A by-election will be held to fill a vacancy in membership of LegCo. However, no by-election is to be held within the 4 months preceding the end of the LegCo’s current term of office or if the CE has published in the Gazette an order dissolving that LegCo in accordance with the Basic Law. *[Amended in October 2007, June 2012 and June 2016]*

1.3 At its Sixteenth Session on 28 August 2010, the Standing Committee of the Eleventh National People's Congress recorded the amendment to Annex II to the Basic Law concerning the formation of the LegCo. As set out in the aforesaid Annex II, the fifth term of the LegCo shall be composed of 70 members and the composition shall be as follows:

- | | | |
|-----|---|----|
| (a) | Members returned by geographical constituencies
("GCs") through direct elections | 35 |
| (b) | Members returned by functional constituencies
("FCs") | 35 |

[Amended in January 2010 and June 2012]

1.4 In addition, in accordance with the decision adopted by the Standing Committee of the National People's Congress on 31 August 2014, the formation method and procedures for voting on bills and motions of the fifth term LegCo will continue to apply to the sixth term LegCo of the HKSAR in 2016. *[Added in June 2016]*

Geographical Constituency

1.5 The HKSAR is divided into 5 GCs, each having 5 to 9 seats. The GCs are geographically based and a total of 35 LegCo members will be returned through the following 5 GCs: Hong Kong Island to return 6 members; Kowloon East to return 5 members; Kowloon West to return 6 members; New Territories East to return 9 members; and New Territories West to return 9 members. The list system of proportional representation for voting is adopted. Details of the features of GC elections are set out in Chapter 2. *[Amended in July 2008, June 2012 and June 2016]*

Functional Constituency

1.6 For the sixth term of the LegCo, there is a total of 29 FCs. The 28 traditional FCs (for the purpose of the Guidelines, “traditional FCs” mean all FCs other than District Council (second) FC (“DC (second) FC”)) each represents a different economic, social, or professional sector of the community, whereas the DC (second) FC is composed of persons who are registered as electors for GCs but are not registered as electors for any of the other 28 FCs. 35 LegCo members will be returned through the following 29 FCs: (1) Heung Yee Kuk; (2) Agriculture and Fisheries; (3) Insurance; (4) Transport; (5) Education; (6) Legal; (7) Accountancy; (8) Medical; (9) Health Services; (10) Engineering; (11) Architectural, Surveying, Planning and Landscape; (12) Labour; (13) Social Welfare; (14) Real Estate and Construction; (15) Tourism; (16) Commercial (first); (17) Commercial (second); (18) Industrial (first); (19) Industrial (second); (20) Finance; (21) Financial Services; (22) Sports, Performing Arts, Culture and Publication; (23) Import and Export; (24) Textiles and Garment; (25) Wholesale and Retail; (26) Information Technology; (27) Catering; (28) District Council (“DC”) (first); and (29) DC (second). Of these 29 FCs, the Labour FC is to return 3 members, the DC (second) FC is to return 5 members and the remaining 27 FCs are each to return 1 member. [Ss 20 and 21 of the LCO] *[Amended in June 2012 and June 2016]*

1.7 Different voting systems apply to elections of different FCs. They are:

- (a) the preferential elimination system of voting for the election for the 4 special FCs (“SFCs”), i.e. Heung Yee Kuk FC, Agriculture and Fisheries FC, Insurance FC and Transport FC;
- (b) the list system of proportional representation for the election of DC (second) FC; and

- (c) the first past the post voting system for the election of the other 24 ordinary FCs (for the purpose of the Guidelines, “ordinary FCs” mean all FCs other than SFCs and DC (second) FC).

[Ss 49(2), 50(2) and 51(2) of the LCO]

Details of the features of FC elections are set out in Chapter 3. *[Amended in June 2012]*

Governing Legislation

1.8 The LegCo elections are governed by the statutory requirements provided in 3 different ordinances, namely the LCO, the Electoral Affairs Commission Ordinance (Cap 541) (“EACO”) and the Elections (Corrupt and Illegal Conduct) Ordinance (Cap 554) (“ECICO”).

1.9 The LCO provides for the constitution and membership of LegCo, establishment of constituencies, registration of electors, conduct of elections, financial assistance for candidates, election petitions and other related matters.

1.10 The EACO tasks the Electoral Affairs Commission (“EAC”) with making recommendations regarding the delineation of GCs for the LegCo election and demarcation of their boundaries and regulating the printing of particulars relating to candidates on ballot papers and financial assistance for candidates. The EAC is also responsible for the conduct and supervision of elections and matters incidental thereto.

1.11 The ECICO prohibits election-related corrupt and illegal conduct and is administered by the Independent Commission Against Corruption (“ICAC”).

1.12 These ordinances are complemented by a number of subsidiary legislation, including those set out in paras. 1.13 to 1.20 below, which provide the detailed procedures for the conduct of the LegCo elections. *[Amended in October 2007]*

1.13 The electoral procedures for conducting the LegCo elections are provided in the Electoral Affairs Commission (Electoral Procedure) (Legislative Council) Regulation (Cap 541D) (“EAC (EP) (LC) Reg”).

1.14 The Electoral Affairs Commission (Registration of Electors) (Legislative Council Geographical Constituencies) (District Council Constituencies) Regulation (Cap 541A) (“EAC (ROE) (GC) Reg”) and the Electoral Affairs Commission (Registration) (Electors for Legislative Council Functional Constituencies) (Voters for Election Committee Subsectors) (Members of Election Committee) Regulation (Cap 541B) (“EAC (ROE) (FCSEC) Reg”) set out the procedures for registration of electors for the LegCo elections.

1.15 The Particulars Relating to Candidates on Ballot Papers (Legislative Council and District Councils) Regulation (Cap 541M) (“PCBP (LC & DC) Reg”) sets out the procedures for printing specified particulars relating to candidates on ballot papers for use in the LegCo elections.

1.16 The Electoral Affairs Commission (Financial Assistance for Legislative Council Elections and District Council Elections) (Application and Payment Procedure) Regulation (Cap 541N) (“EAC (FA) (APP) Reg”) stipulates the detailed implementation procedures for the Financial Assistance Scheme for candidates standing in LegCo elections. *[Amended in October 2007]*

1.17 The Legislative Council (Subscribers and Election Deposit for Nomination) Regulation (Cap 542C) (“LC Subscribers & Deposit Reg”) sets

out the requirements for subscription and payment and return of election deposit for the LegCo elections.

1.18 The Electoral Affairs Commission (Nominations Advisory Committees (Legislative Council)) Regulation (Cap 541C) (“EAC (NAC) (LC) Reg”) stipulates the appointment and functions of the Nominations Advisory Committees (“NACs”) and the procedures for seeking the NAC’s advice on the candidates’ eligibility for nomination for the LegCo elections.

1.19 The Maximum Amount of Election Expenses (Legislative Council Election) Regulation (Cap 554D) sets out the maximum amount of election expenses that may be incurred by or on behalf of a candidate, or all the candidates on a list, for election to the LegCo. *[Added in October 2007 and amended in July 2008]*

1.20 The Legislative Council (Election Petition) Rules (Cap 542F) set out the procedures for the lodgement of an election petition against the result of the LegCo elections. *[Added in October 2007]*

PART II : THE GUIDELINES

1.21 According to s 6 of the EACO, the EAC may, in connection with an election, issue guidelines relating to:

- (a) the conduct or supervision of or procedure at an election;
- (b) the activities of a candidate, an agent of a candidate or any other person assisting a candidate, or any other person;
- (c) election expenses;

- (d) the display or use of election advertisements (“EAs”) or other publicity materials; and
- (e) the procedure for making a complaint.

1.22 The aim of such guidelines is to provide a code of conduct based on the principle of fairness and equality for conducting election-related activities. They also give guidance in layman’s language on the compliance with the relevant electoral legislation. Guidelines are issued for reference by the public to ensure that all public elections are conducted in an open, honest and fair manner. *[Amended in June 2012]*

1.23 This set of Guidelines explains the various electoral arrangements made for the LegCo elections, the legislative provisions and regulations as well as guidelines that should be observed by all parties concerned before, during and after an election and the procedure for lodging an election-related complaint. An action checklist for candidates can be found at **Appendix A**.

1.24 In the context of this set of Guidelines, the term “election” means general election or by-election, as appropriate.

PART III : SANCTION

1.25 Electors, candidates and their agents as well as government officials engaged in election-related duties, or members of the public as the case may be, should read, familiarise themselves with, and strictly observe, the Guidelines.

1.26 The EAC is committed to ensuring that all elections are conducted openly, honestly and fairly. If it comes to know that any candidate or person is in breach of the Guidelines, apart from notifying the relevant

authorities for actions to be taken, it may make a reprimand or censure in a public statement which will include the name of the candidate or person concerned and, where appropriate, other relevant parties (if any). The reprimand or censure is separate from and in addition to the criminal liability for any offences committed. *[Amended in July 2008]*

CHAPTER 2

GEOGRAPHICAL CONSTITUENCIES

PART I : DESCRIPTION

2.1 This chapter describes the GCs and the electoral procedures of GCs.

2.2 In the general election for the sixth term of the LegCo, the 5 GCs are to return 35 of the 70 members of the LegCo, as follows:

- (a) the Hong Kong Island GC to return 6 members;
- (b) the Kowloon East GC to return 5 members;
- (c) the Kowloon West GC to return 6 members;
- (d) the New Territories East GC to return 9 members; and
- (e) the New Territories West GC to return 9 members.

[Amended in July 2008, June 2012 and June 2016]

PART II : REGISTRATION OF ELECTORS

Eligibility to Vote

2.3 Only a registered elector is eligible to vote at a LegCo election.

A registered elector is a person whose name appears on the final register of GC which is in force at the time of election as compiled and published by the Electoral Registration Officer (“ERO”) under the LCO. A person may only vote at an election in respect of the GC for which the person is registered as an elector in the final register. [S 48 of the LCO] *[Amended in January 2010]*

Qualifications for Registration as an Elector

2.4 To qualify for registration as an elector in a GC, an individual has to satisfy all the following requirements:

- (a) in any year other than a year in which a DC ordinary election is to be held (“non DC election year”), he/she has to be aged 18 years or above as at 25 July next following his/her application for registration (or 25 September in a DC election year) [s 29 of the LCO]; *[Amended in October 2007]*
- (b) he/she is a permanent resident of Hong Kong [s 27 of the LCO];
- (c) (i) he/she ordinarily resides in Hong Kong and the residential address in his/her application for registration is his/her only or principal residence in Hong Kong [s 28(1) of the LCO]; or
 - (ii) if he/she is a person serving a sentence of imprisonment and at the time of the application does not have a home in Hong Kong outside the prison, the following prescribed address is deemed to be the person’s only or principal residence in Hong Kong for the purpose of voter registration:
 - (1) the last dwelling-place in Hong Kong at which the

person resided and which constituted his/her sole or main home; or

- (2) the residential address of the person last recorded by the Immigration Department under the Registration of Persons Regulations (Cap 177A) if the person cannot provide any proof on his/her last dwelling-place in Hong Kong. [S 28(1A) and (1B) of the LCO] *[Amended in January 2010]*
- (d) he/she holds an identity document or has applied for a new identity document or a replacement identity document [s 30 of the LCO]; and
- (e) he/she is not disqualified from being registered as an elector by virtue of s 31 of the LCO.

[Amended in October 2007, January 2010 and June 2012]

2.5 A person who is **already registered** in the existing final register of GCs **need not apply** to be registered as an elector in a GC any further as his/her name and residential address will be repeated in the next register (a provisional register) [s 8(1) of the EAC (ROE) (GC) Reg]. However, he/she is not entitled to be included as an elector in the next register of GCs if:

- (a) he/she has ceased to ordinarily reside in Hong Kong [s 24(2)(a) of the LCO];
- (b) he/she no longer resides at the residential address recorded against his/her name in the existing register and the ERO does not know his/her new principal residential address in Hong Kong [s 24(2)(b) of the LCO and s 9(2) of the EAC (ROE) (GC) Reg]

(see para. 2.14 below);

- (c) he/she is no longer a permanent resident of Hong Kong [s 27 of the LCO];
- (d) he/she was an imprisoned person who used his/her last dwelling-place in Hong Kong at which he/she resided or the address last recorded under the Registration of Persons Regulations as the address for registration as an elector and who had served his/her sentence of imprisonment and left the prison without reporting his/her new residential address to the ERO [s 9(2A) of the EAC (ROE) (GC) Reg] *[Amended in January 2010]*; or
- (e) he/she is disqualified from being registered as an elector by virtue of s 31 of the LCO.

[Amended in January 2010 and June 2012]

Disqualifications

2.6 A natural person is disqualified from being registered as an elector and voting at an election for a GC if he/she:

- (a) has ceased to be eligible to be registered as an elector for such a GC [ss 27, 28 and 53(1) of the LCO];
- (b) is found for the time being to be incapable, by reason of mental incapacity, of managing and administering his/her property and affairs under the Mental Health Ordinance (Cap 136) [ss 31(1) and 53(5) of the LCO]; or

(c) is a member of any armed forces [ss 31(1) and 53(5) of the LCO].

[Amended in January 2010 and June 2012]

Application for Registration and Deregistration

2.7 The registration of GC electors is undertaken in accordance with the provisions of the EAC (ROE) (GC) Reg.

2.8 A person may send in his/her application for voter registration or deregistration to the ERO any time in the year. However, for inclusion/exclusion of his/her name in the final register of GCs to be published not later than 25 July in a non DC election year (or 25 September in a DC election year), his/her application must have been received by the ERO **not later than 2 May** in that year (or 2 July in a DC election year). [S 4 of the EAC (ROE) (GC) Reg] *[Amended in June 2016]*

2.9 The ERO will process the application form for registration (REO-1) and notification of deregistration¹ after they have been received. The ERO will send written enquiries to applicants to seek information or proof if the information on their applications/notification is incomplete or incorrect. An applicant who qualifies for registration will be allocated to the relevant GC on the basis of his/her residential address. Applicants who are not qualified for registration will also be informed of the result by surface mail. *[Amended in January 2010, June 2012 and June 2016]*

2.10 The name and residential address of all eligible applicants will be entered in the registers of electors.

¹ Application form: Application for Voter Registration (Geographical Constituencies)/District Council (Second) Functional Constituency/Report on Change of Particulars, also known as “REO-1”, is available on www.reo.gov.hk. For deregistration, no specified form is required but the written notice should be signed by the elector.

Change of Residential Address and other Personal Particulars

2.11 It will not be necessary for a registered elector to re-apply for registration every year. However, if a registered elector has changed his/her residential address, he/she **should notify** the ERO of **his/her new address** in Hong Kong to ensure that he/she will continue to be registered in the next register of electors. *[Amended in January 2010 and June 2012]*

2.12 Apart from residential address, any registered elector who has changed his/her other particulars (e.g. name, telephone numbers and email address) should also notify the ERO of such change. *[Amended in January 2010]*

2.13 An elector should notify the ERO of any change of his/her registration particulars by letter to or sending an application form to the ERO to report the change of particulars. In order to allow the alteration of his/her particulars to be effected in the next final register of electors, he/she **should notify** the ERO as soon as possible and **latest by 2 May in a non DC election year** (or 2 July in a DC election year) [s 11(5) of the EAC (ROE) (GC) Reg]. An elector who has reported a change of particulars will be sent a notice by the ERO showing his/her updated electoral record [s 11(4) of the EAC (ROE) (GC) Reg]. *[Amended in January 2010 and June 2016]*

2.14 An elector has the civic responsibility to notify the ERO of any change in his/her principal residential address in Hong Kong in a timely manner. To enhance the accuracy of the register of electors, the Registration and Electoral Office (“REO”) has put in place suitable checking measures. If **it has come to the knowledge of the ERO that an elector’s registered address might not be up-to-date**, the ERO will invoke the statutory inquiry process to ascertain whether the address recorded in the existing register is still the elector’s only or principal residential address in Hong Kong [s 7(1) of the EAC (ROE) (GC) Reg]. **The elector’s name and other registration**

particulars may be removed from the next register of electors if he/she fails to respond to the satisfaction of the ERO during the inquiry process. Meanwhile, for any election held before the publication of the next register, the person remains a registered elector for the GC as recorded in the current register of electors [s 48 of the LCO]. It is of utmost importance for electors to provide the ERO with true, accurate and updated information for voter registration and it is an offence for a person to knowingly or recklessly give false or misleading information for voter registration no matter whether or not he/she subsequently votes at an election [s 22 of the EAC (ROE) (GC) Reg]. *[Added in January 2010 and amended in June 2016]*

The Provisional Register

2.15 The provisional register for GCs will be published **not later than 1 June in a non DC election year** (no later than 1 August in a DC election year). It should include:

- (a) the names and residential addresses of those electors whose names appear in the existing final register for GC currently in force, updated and corrected by the ERO based on reported or available information; and
- (b) the names and residential addresses of the eligible new applicants who have applied for registration in the constituency concerned on or before 2 May of that year (or 2 July in a DC election year).

The provisional register will be **available for public inspection** at the REO and District Offices (“DOs”) as specified in the Gazette notice of publication for a period after its publication and before the appeal deadline referred to in para. 2.19 below. Upon request by a person imprisoned or held in custody by a law enforcement agency, the ERO may make available, at a penal institution or the premises of a law enforcement agency as the case may be, a copy of the

provisional register for his/her inspection if the ERO considers it appropriate to do so. The ERO may require persons who want to inspect the provisional register to produce an identity document and complete a form furnished by him/her. [Ss 12 and 13 of the EAC (ROE) (GC) Reg] *[Amended in January 2010 and June 2016]*

The Omissions List

2.16 At the same time when the provisional register for GCs is published, the ERO will also publish for public inspection an omissions list, containing the names and residential addresses of persons formerly registered as GC electors. The omissions list may also be made available at a penal institution or the premises of a law enforcement agency for inspection on request. These particulars are struck out from the provisional register and proposed to be omitted from the next final register, where the ERO is satisfied on reasonable grounds based on the information received that these persons do not wish to remain registered in the register of electors; or are no longer eligible to be registered; or have been disqualified [s 32(4)(a) and (b) of the LCO and s 9(1) of the EAC (ROE) (GC) Reg]. For an imprisoned person who used his/her last dwelling-place in Hong Kong at which he/she resided or the address last recorded under the Registration of Persons Regulations as the address for registration as an elector, if the ERO is satisfied on reasonable grounds that he/she has served his/her sentence of imprisonment and left the prison without reporting his/her new residential address to the ERO, the ERO shall enter his/her name and residential address on the omissions list according to the procedures prescribed in the relevant legislation [s 9(2A) of the EAC (ROE) (GC) Reg]. *[Amended in January 2010 and June 2016]*

2.17 The names and residential addresses of the persons included in the omissions list will not appear on the provisional register [s 32(4)(a) and (b) of the LCO and s 9(3) of the EAC (ROE) (GC) Reg]. *[Added in January 2010]*

Online Voter Information Enquiry System

2.18 The REO launched the Online Voter Information Enquiry System (OVIES) (www.voterinfo.gov.hk) in September 2014 to facilitate the public to check whether they are registered electors and whether their registration particulars are accurate. The public may log on to the system anytime to check whether they are registered as electors and their latest registration particulars including registered addresses and respective constituencies.
[Added in June 2016]

Appeals – Objections and Claims

2.19 Any person may lodge in person with the ERO objections as regards entries in the relevant provisional register **not later than 25 June in a non DC election year** (or 25 August in a DC election year) [s 14(2) of the EAC (ROE) (GC) Reg]. The procedures for making claims or objections are provided in the REO website (www.reo.gov.hk) during the public inspection period. On or before that date, an applicant whose name has not been recorded in the provisional register, or an elector whose particulars have not been correctly recorded or an elector whose name has been included in the omissions list may lodge a claim in person with the ERO in respect of the entry or any omission concerning himself/herself [s 15(1), (2) and (7) of the EAC (ROE) (GC) Reg]. To facilitate a person imprisoned or held in custody by a law enforcement agency to make such an objection or claim, he/she is allowed to deliver a notice of objection or claim to the ERO by post. Cases of objections and claims will be referred to the Revising Officer² for consideration. The Revising Officer, who is a judicial officer, will rule on each objection or claim and decide on the inclusion, exclusion or correction of the entry concerned in the relevant final register. [S 34 of the LCO and Part 3

² The Revising Officer may be any magistrate, or any legal officer within the meaning of the Legal Officers Ordinance (Cap 87), appointed by the Chief Justice [s 77(1) of the LCO].

of the EAC (ROE) (GC) Reg] *[Amended in January 2010 and June 2016]*

The Final Register

2.20 The final register for GCs will be published **not later than 25 July in a non DC election year** (no later than 25 September in a DC election year). It will include the entries in the relevant provisional register with the updated names and residential addresses of electors who have applied to alter their particulars and the names and residential addresses of those who were subject to a notice of objection or claim as updated and corrected to reflect the decisions of the Revising Officer. The ERO will also take the opportunity to delete those entries of electors who are known to have died and to correct any mistakes in the provisional register. This final register shall remain valid until the publication of the final register in the following year. The final register in force is available for public inspection at the REO and DOs. Upon request by a person imprisoned or held in custody by a law enforcement agency, the ERO may make available at a penal institution or the premises of a law enforcement agency as the case may be a copy of the final register for his/her inspection if the ERO considers it appropriate to do so. The ERO may require persons who want to inspect the final register to produce an identity document and complete a form furnished by him/her. [S 20 of the EAC (ROE) (GC) Reg] *[Amended in January 2010 and June 2016]*

IMPORTANT :

Information relating to a person contained in any register of electors or in any extract of any register of electors **can only be used for election-related purposes** under the electoral legislation. Any **abuse** or **misuse** of such information is an **offence** and will be liable to a fine at level 2 (\$5,000) and to imprisonment for 6 months [s 22(3) of the EAC (ROE) (GC) Reg].

PART III : THE VOTING SYSTEM FOR GEOGRAPHICAL CONSTITUENCIES

2.21 For GCs, the list system of proportional representation applies [s 49(2) of the LCO].

2.22 A poll will be taken in respect of a GC to return members for that constituency if the number of validly nominated candidates contesting the election is more than the number of members to be returned for the constituency. Where no more candidates have been validly nominated than the number of members to be returned for the constituency, the validly nominated candidates will be declared elected by the Returning Officer (“RO”) [s 46(1) of the LCO]. In such a case, polling in respect of the constituency will not be necessary and electors of the constituency concerned should not attend the relevant polling stations since they no longer need to vote. If no candidates were validly nominated or the number validly nominated was less than the number of members to be returned for the constituency, the RO must declare the election to have failed or, as the case may be, to have failed to the extent that the number of candidates validly nominated was less than the number of members to be returned [s 46(2) of the LCO]. A by-election will then be necessary.

2.23 In the list system of proportional representation, the nomination of candidates is to be by way of a list in a nomination form specified by the EAC to contain the names of one or more candidates for a GC as a group, and if more than one name, the names have to be ranked in the order of priority of the group. After the RO of the relevant GC has determined the eligibility of the candidates on a nomination list, only the eligible candidates whose priority on the list is below or equals the number of vacancies in the GC will be allowed to remain as candidates, and other candidates on the same list who rank after those prior candidates will have their names excluded from the

nomination list. If, after the end of the nomination period but before the date of the election, proof is given to the satisfaction of the RO that a candidate whose name appears on a list of candidates has died or is disqualified from being nominated as a candidate, the RO must strike out the name of that candidate from the list. After striking out a name from a list of candidates, the RO must not add the name of any other person to the list. If no name remains on the list of candidates, the RO must reject the list. [S 38 of the LCO]

2.24 At a GC election, an elector is entitled to cast a **single vote for a list** (as shown on the ballot paper) and not for an individual candidate. The number of valid votes cast for the election of the GC will be divided by the number of vacancies to be elected for that GC to arrive at the quota of votes. Each list that gets the quota will have one candidate on the list elected. When not all the vacancies are filled by applying the quota, then the filling of the remaining seat or seats will be decided by the largest remainder of valid votes cast for each list after the deduction of the quota or a number of quotas of votes cast for that list. If there are votes cast for a list that exceed the quota or quotas necessary to return all the candidates in the list, the list will be treated as having no further votes remaining. [S 49 of the LCO] For example, in a GC to elect 5 LegCo members, i.e. with 5 vacancies, where the number of valid votes cast is 1 million and there are 6 lists with varying number of candidates, the voting system operates in the following manner:

The quota of votes required to elect 1 candidate = $1,000,000 \div 5 = 200,000$

The valid votes cast for the 6 lists, e.g.:

<u>List 1</u>	<u>List 2</u>	<u>List 3</u>	<u>List 4</u>	<u>List 5</u>	<u>List 6</u>
Candidate A	Candidate F	Candidate J	Candidate M	Candidate O	Candidate Q
Candidate B	Candidate G	Candidate K	Candidate N	Candidate P	
Candidate C	Candidate H	Candidate L			
Candidate D	Candidate I				
Candidate E					
290,000	270,000	80,000	120,000	30,000	210,000
votes	votes	votes	votes	votes	votes
(votes cast for each of the Lists)					

Step 1

No. of candidates in each list returned for satisfying the quota with the remainder votes:

<u>List 1</u>	<u>List 2</u>	<u>List 3</u>	<u>List 4</u>	<u>List 5</u>	<u>List 6</u>
Candidate A	Candidate F	None	None	None	Candidate Q
90,000	70,000	80,000	120,000	30,000	10,000
votes	votes	votes	votes	votes	votes
					(treated as no votes remaining)

(On applying the quota, 200,000 votes for List 1 enables Candidate A, being the first candidate in the priority ranking of List 1, to be elected. On the same basis, Candidate F on List 2 and Candidate Q on List 6 are elected. The remainder votes for List 1 and List 2 are then used to compare with the votes not meeting the quota cast for the other lists.)

Step 2

No. of candidates in each list returned by applying the remainder votes:

<u>List 1</u>	<u>List 2</u>	<u>List 3</u>	<u>List 4</u>	<u>List 5</u>	<u>List 6</u>
Candidate B	None	None	Candidate M	None	None

(Candidate M has the highest remainder of 120,000 votes, and candidate B has the next highest remainder of 90,000 votes. There are only 2 available vacancies after applying the quota in step 1, and they are filled by these 2 candidates whose lists have the highest 2 remainder votes in step 2. The rest of the candidates are not elected.)

2.25 If it is found that 2 or more lists have the equal largest number of remaining votes and the number of those lists exceeds the number of members remaining to be returned at that stage, the RO must determine the result by drawing lots. The member/members will be returned from the list/lists on which the lot falls. [S 49(11) of the LCO]

2.26 When the drawing of lots has to be used to determine the result, 10 table-tennis balls each marked with a number from 1 to 10 will be put into an empty opaque bag, to be provided by the RO. The candidate or the representative of a candidate list is to draw 1 ball from the bag. The number marked on the ball should be noted by the RO and the ball should be put back into the bag. The other candidate(s) or representative(s) of candidate list(s) will draw in the same way. The RO would draw the lot on behalf of the candidate or the representative of a candidate list if such candidate or representative is absent at the time of drawing lots. The candidate on whom the lot falls is to be returned at the election:

- (a) Where there is only 1 vacancy to be filled and there are 2 candidates, the candidate who obtains the larger number from 1 to 10 will be the winner. 1 is the smallest number and 10 is the largest number.
- (b) Where there is only 1 vacancy to be filled and there are more than 2 candidates, if in the first draw, the numbers drawn are different, then the candidate who obtains the largest number will win. If, on the other hand, 2 or more of the candidates have obtained the

same larger number and the remaining candidate(s) has/have obtained a smaller number, there must be a second draw. Only those candidates who have obtained the same larger number in the first draw will participate in the second draw.

- (c) Where there are 3 candidates having an equal number of votes and there are only 2 vacancies to be filled, if the 3 candidates have obtained respectively the largest, the larger and the smallest numbers, the 2 candidates who have obtained the largest and the larger numbers should be successful in getting the 2 vacancies, and the remaining candidate will fail. If the 3 candidates have obtained respectively 2 larger equal and 1 smaller numbers, then again the 2 candidates who have obtained the larger equal numbers will be the winners to fill the 2 vacancies. If the 3 candidates have obtained respectively a larger and 2 equal smaller numbers, the candidate who has obtained the larger number will be successful and the remaining 2 candidates will participate in a second draw. The same principle will apply where there are N candidates having an equal number of votes and there are less than N vacancies to be filled.

2.27 As soon as practicable after the result of the elections has been determined, the RO should publicly declare the successful candidates as elected. In case of the death or disqualification of a candidate, the voting arrangement is described in paras. 2.28 to 2.30 below.

Death or Disqualification of a Candidate for GC

2.28 If the death or disqualification of a candidate is proved to the satisfaction of the RO before the election day but after the RO has decided that the candidate is validly nominated, the RO must, as soon as practicable, publicly declare that the candidate has died or that the RO's earlier decision is

varied to the effect that the candidate is not validly nominated. The RO must further declare which candidates are validly nominated for election for the relevant constituency. [Ss 42A and 42B of the LCO] *[Added in June 2016]*

2.29 In the event that on the polling day but before the close of poll for the election, proof is given to the satisfaction of the RO that a validly nominated candidate has died or has been disqualified from being elected, the RO should publicly declare that the proceedings for the election for the constituency are terminated. The declaration is to be made by a notice displayed in a prominent place outside each polling station of the relevant constituency and published in the Gazette as soon as practicable. [S 46A(1) of the LCO and s 97(1) of the EAC (EP) (LC) Reg] *[Added in June 2016]*

2.30 If after the close of poll, proof is given to the RO's satisfaction that a candidate on a list has died or has been disqualified from being elected, the RO should complete the counting of votes. After the counting of votes is finished, if the candidate concerned is found to be successful at the election, and if there is another candidate or there are other candidates on the same list who has not or have not been returned for the constituency, the candidate is to be returned or a candidate is to be returned according to the order of priority on the list in place of the deceased or disqualified candidate. If there is no other candidate on the same list who can be returned, the RO should not declare that candidate as elected and should declare that the election for that constituency has failed or has failed to the extent that the number of candidates returned at the election for the constituency was less than the number of members to be returned for the constituency. [Ss 46A(2), (3), (4), 49(14), (15) and (16) of the LCO and s 83(2)(a), (b)(i) and 97A of the EAC (EP) (LC) Reg] *[Amended in June 2016]*

CHAPTER 3

FUNCTIONAL CONSTITUENCIES

PART I : COMPOSITION

3.1 This chapter describes the FCs and the electoral procedures of FCs.

3.2 In the general election for the sixth term of the LegCo, the 29 FCs are to return 35 of the 70 members of the LegCo. *[Amended in July 2008, June 2012 and June 2016]*

3.3 The electorates of the 28 traditional FCs are from particular professional, industrial or trade groups, etc. The DC (second) FC is composed of persons who are registered as electors for GCs but are not registered as electors for any of the other 28 FCs. Except the Labour FC that is to return 3 members to the LegCo and the DC (second) FC that is to return 5 members to the LegCo, each of the other 27 FCs will return 1 member [s 21 of the LCO]. The FCs and their electors are provided for in ss 20A to 20ZC of and Schedules 1 to 1E to the LCO, and are set out in **Appendix B**. *[Amended in June 2012]*

PART II : REGISTRATION OF ELECTORS

Eligibility to Vote

3.4 Only a registered elector, i.e. a person whose name appears on the final register of FC which is in force at the time of the election is eligible to vote. An elector may only vote at an election in respect of a FC if he/she is

registered as an elector in that constituency in the final register. [S 48 of the LCO]

Qualification for Registration as an Elector

An Elector of the 29 FCs

3.5 A natural person (individual) or a body may be eligible to be registered as a FC elector. A person who is one specified in column 2 of Appendix B opposite a FC is eligible to be registered as an elector for that FC but if the person is an individual, he/she must **also** be either registered for a GC or eligible to be registered for a GC and has made an application to be so registered. (For registration as an elector for a GC, please refer to para. 2.4 of Chapter 2.) [S 25(1) of the LCO]

3.6 If a person/body is **already registered** in the existing final register for a FC and is eligible to be, and not disqualified from, being registered as an elector for the FC, then his/her/its name and address will be repeated in the next provisional register for FCs, and he/she/it **needs not apply** to be registered. *[Amended in June 2012]*

3.7 A body specified in item 3, 12, 20, 21(1), 22(2), (4), (5), (10) or (11), 23(1) to (4), 24(4) or (5), 26(13) or 27(1) of Appendix B is eligible to be registered as a corporate elector for the relevant FC only if it has been operating for the 12 months immediately before making its application for registration as an elector. [S 25(4) of the LCO] *[Amended in October 2007]*

3.8 A body that is a corporate member of a representative organisation specified in item 2(1), 14 to 19, 21(2), 22(1) or (7) to (9), 23(5), 24(1) or (2), 25 or 26(10), (11)(a) or (12) of Appendix B is eligible to be registered as a corporate elector for the relevant FC if it has been a corporate member of the representative organisation and has been operating for the 12

months immediately before making its application for registration as an elector.
[S 25(5) of the LCO]

3.9 An individual who is a member of a representative organisation specified in item 14, 17, 18, 22(7) or (9), 23(5), 24(3), 25 or 26(14) or (15) of Appendix B is eligible to be registered as an elector for the relevant FC only if the person has been a member of the body for the 12 months immediately before making an application for registration as an elector. [S 25(6) of the LCO] *[Amended in October 2007 and June 2016]*

3.10 No person/body may be registered in 2 or more FCs. If he/she/it is eligible to be registered in 2 or more FCs, he/she/it may choose to be registered in any one of the FCs **unless** he/she/it is eligible in the DC (first) FC and/or any one of the 4 SFCs shown in para. 3.12. [S 25(2) of the LCO]

3.11 If a person is eligible to be registered in the DC (first) FC and any other FC at the same time, he/she has no choice and may only be registered in the DC (first) FC and not in any other FC.

3.12 Subject to para. 3.11, if a person/body who/which is eligible to be registered in one of the following 4 SFCs:

- (a) Heung Yee Kuk FC;
- (b) Agriculture and Fisheries FC;
- (c) Insurance FC; and
- (d) Transport FC.

and if he/she/it wants to be registered as an FC elector, he/she/it has **no choice but** to be registered in that FC although he/she/it may be eligible for any other

FC [s 25(3) of the LCO]. The voting system for these 4 SFCs is different from that for the 24 ordinary FCs and the DC (second) FC [see paras. 3.33 to 3.43 below]. These 4 SFCs are specified in s 20(1)(a) to (d) of the LCO (items 1 - 4 of Appendix B). *[Amended in June 2012]*

An Authorised Representative of a Corporate Elector

3.13 A corporate elector is required to select an eligible individual to be its authorised representative (“AR”) for the purpose of casting its vote at any election, otherwise it cannot vote [see also s 48(8) of the LCO]. An individual is eligible to be appointed as an AR of a corporate elector only if he/she:

- (a) is registered, or eligible to be and has applied to be registered, as an elector of a GC;
- (b) is a member, partner, officer or employee of the corporate elector or has a substantial connection with it;
- (c) is not registered, and has not applied to be registered, as an elector for the same FC of the corporate elector; and
- (d) is not disqualified from being registered or voting under s 31 or 53 of the LCO [see para. 3.16 below].

[S 26(1) and (2) of the LCO]

3.14 An AR of a corporate elector is not eligible to be selected as the AR of another corporate elector. [S 26(3) of the LCO]

3.15 An AR must be registered with the ERO. **A corporate elector is required to give notice of appointment of its AR to the ERO in its application form for registration as a corporate elector.** It may thereafter

from time to time appoint a replacement AR by sending a specified form to reach the ERO not later than 14 days before the polling day of its FC. [S 26(4) and (5) of the LCO] If the ERO is satisfied that the AR has died or is seriously ill or physically or mentally incapacitated, the deadline of 14 days for replacement is extended to 3 working days before the relevant polling day [s 20 of the EAC (ROE) (FCSEC) Reg].

Disqualifications

3.16 A natural person is disqualified from being registered as an elector and voting at an election for a FC or as an AR if he/she:

- (a) has ceased to be eligible to be registered as an elector for the GC;
- (b) has ceased to remain qualified for the FC (this does not apply to an AR or an elector for a GC);
- (c) is found for the time being to be incapable, by reason of mental incapacity, of managing and administering his/her property and affairs under the Mental Health Ordinance (Cap 136); or
- (d) is a member of any armed forces.

[Ss 31(1), 53(1) and (5) of the LCO] *[Amended in January 2010]*

3.17 A consular post to which any privilege or immunity is accorded under the Consular Relations Ordinance (Cap 557) and an organisation to which s 2 of the International Organizations and Diplomatic Privileges Ordinance (Cap 190) applies or an international organisation defined in s 2 of the International Organizations (Privileges and Immunities) Ordinance (Cap 558) are disqualified from being registered as a corporate elector. In addition, a body which is a department or an agency of a government of a place

outside the People's Republic of China, whether at national, regional or municipal level, is also disqualified from being registered as a corporate elector and, for the purpose of this disqualification requirement, a body will not be regarded as a department or an agency of a government of a place unless the management of the body is appointed by the government and is answerable to the government; the principal function of the body is to advance the interest of the place and the body is non-profit-making. [S 31 of the LCO] *[Added in June 2012]*

Application for Registration and Deregistration

3.18 The registration of FC electors is undertaken in accordance with the provisions of the EAC (ROE) (FCSEC) Reg.

3.19 A person (either an individual or a body) may send his/her/its application for voter registration or deregistration to the ERO any time in the year. However, for inclusion/exclusion of his/her/its name in the final register to be published not later than 25 July in a non DC election year (or 25 September in a DC election year), his/her/its application must be received by the ERO **not later than 2 May of that year** (or 2 July in a DC election year). [S 19 of the EAC (ROE) (FCSEC) Reg] *[Amended in June 2016]*

3.20 The ERO will process the application form for registration (REO-41 or REO-42) and notification of deregistration³ after they have been received. The ERO will send written enquiries to applicants to seek information or proof if the information on their applications/notifications is incomplete or incorrect. An applicant who qualifies for registration will be allocated to the relevant FC, as appropriate, in accordance with his/her qualification and choice (if so entitled). Applicants who are not qualified for

³ Application form: Application by **an individual** for registration in a FC/report on change of particulars, also known as "REO-41", and Application by **a body** for registration in a FC/report on change of particulars, also known as "REO-42", are available on www.reo.gov.hk. For deregistration, no specified form is required but the written notice should be signed by the elector/responsible person.

registration will also be informed by surface mail. *[Amended in January 2010 and June 2016]*

3.21 The names and addresses (business addresses for corporate electors) of all eligible applicants will be entered in the registers of electors. The ARs (if appointed) of the corporate electors will also be included in the registers of electors. *[Amended in June 2012]*

Change of Residential Address and other Personal Particulars

3.22 It will not be necessary for a registered elector (either individual or body) to re-apply for registration every year. *[Amended in January 2010]*

3.23 However, in the case of a registered individual elector, please note the following:

- (a) If he/she has changed his/her residential address, he/she **should notify** the ERO **of his/her new address** in Hong Kong to ensure that he/she will continue to be registered in the next register of electors.
- (b) He/She should notify the ERO of any change of circumstances that may affect his/her eligibility (e.g. his/her connection with a particular FC). Based on such information from the elector, the ERO will decide whether he/she remains eligible to be registered, and if so, in which constituency.
- (c) Apart from his/her residential address, any registered elector who has changed his/her other personal particulars (e.g. name, telephone numbers and email address), should also notify the ERO of such change.

- (d) He/She should notify the ERO of any change of his/her registration particulars by letter to or sending an application form to the ERO to report the change of particulars. In order to allow the alteration of his/her particulars to be effected in the next final register of electors, the elector **should notify** the ERO as soon as possible and the **latest by 2 May in a non DC election year** (or 2 July in a DC election year) [s 26(5) of the EAC (ROE) (FCSEC) Reg]. An elector who has reported a change of particulars will be sent a notice by the ERO showing his/her updated electoral record. [S 26 of the EAC (ROE) (FCSEC) Reg]
- (e) If the elector has **failed to update the ERO of his/her new address in Hong Kong**, or ceased to be ordinarily resided in Hong Kong, **his/her name and particulars may be removed from the register of electors.**

[Amended in January 2010, June 2012 and June 2016]

3.24 In the case of a registered corporate elector, if it has changed its particulars (e.g. name, address, telephone number), it should also notify the ERO. In this regard, para. 3.23 (b) and (d) apply to a corporate elector in the same way as they apply to an individual elector. For the AR of a corporate elector, para. 3.23 (a), (b), (c) and (e) above apply to change in his/her particulars. *[Added in January 2010]*

The Provisional Registers

3.25 The provisional register for FCs will be published **not later than 1 June in a non DC election year** (no later than 1 August in a DC election year). It should include:

- (a) the names and addresses of those electors whose names appear in

the existing final register for that FC currently in force, updated and corrected by the ERO based on reported or available information;

- (b) the names and addresses of the eligible new applicants who have applied for registration in the constituency concerned on or before 2 May of that year (or 2 July in a DC election year); and
- (c) the names of the ARs of the corporate electors.

The provisional register for the 28 traditional FCs will be **available for public inspection** at the REO and certain DOs, as specified in the Gazette notice of publication for a period after its publication and before the appeal deadline referred to in para. 3.31 below. The provisional register for the DC (second) FC is compiled in a GC provisional register by means of notes or indications against the names and personal particulars of the concerned electors. The register so compiled is to be regarded for all purposes as a register compiled under the EAC (ROE) (FCSEC) Reg [s 3(2A) of the EAC (ROE) (FCSEC) Reg]. The DC (second) FC provisional register will be made available for public inspection at the REO and DOs as described in para. 2.15 above. Upon request by a person imprisoned or held in custody by a law enforcement agency, the ERO may make available, at a penal institution or the premises of a law enforcement agency as the case may be, a copy of the provisional register for his/her inspection if the ERO considers it appropriate to do so. The ERO may require persons who want to inspect the provisional register to produce an identity document and complete a form furnished by him/her. [Ss 27 and 29 of the EAC (ROE) (FCSEC) Reg] *[Amended in January 2010 and June 2016]*

3.26 A person applying for the registration in a GC provisional register is also regarded as having applied for registration as an elector for the DC (second) FC unless he/she specifies otherwise [s 19(1A) of the EAC (ROE) (FCSEC) Reg]. *[Added in June 2012]*

The Omissions List

3.27 At the same time when the provisional registers are published, the ERO will also publish for public inspection an omissions list each in respect of FCs containing the names and addresses of persons who were formerly registered as FC electors, but are struck out from the provisional register and proposed to be omitted from the next final register, where the ERO is satisfied on reasonable grounds based on the information received that the concerned persons do not wish to remain registered in the register of electors; or are no longer eligible to be registered; or have been disqualified [s 24(1) of the EAC (ROE) (FCSEC) Reg]. The omissions lists may also be made available at a penal institution or the premises of a law enforcement agency for inspection on request. For an imprisoned person who has used his/her last dwelling-place in Hong Kong at which he/she resided or the address last recorded under the Registration of Persons Regulations (Cap 177A) as the address for registration as an elector, if the ERO is satisfied on reasonable grounds that he/she has served his/her sentence of imprisonment and left the prison without reporting his/her new residential address to the ERO, the ERO shall enter his/her name and residential address on the omissions list according to the procedures prescribed in the relevant legislation [s 9(2A) of the EAC (ROE) (GC) Reg]. *[Amended in January 2010 and June 2016]*

3.28 The ERO may make inquiries under the electoral law to the registered FC electors to verify their eligibility for registration. If an FC elector does not respond to the inquiry or the ERO is satisfied on reasonable grounds that the elector is no longer eligible to be registered or is disqualified from being registered in the relevant FC, his/her/its name and relevant particulars will be included in the omissions list of the relevant FC. [Ss 22(1), (2), 24(1) and (1A) of the EAC (ROE) (FCSEC) Reg] *[Added in June 2012]*

3.29 The names and addresses of the persons included in the

omissions list of a FC will not appear on the provisional register of the same FC [s 32(4)(a) and (b) of the LCO and ss 24(1) and 25(1) of the EAC (ROE) (FCSEC) Reg]. *[Amended in June 2012]*

Online Voter Information Enquiry System

3.30 Registered electors (individual or corporate) and AR may log on to the OVIES (www.voterinfo.gov.hk) anytime to check whether they/their corporates are registered as electors and their/the relevant body electors' latest registration particulars including registered addresses and respective constituencies. *[Added in June 2016]*

Appeals – Objections and Claims

3.31 Any person (either an individual or the responsible person of a body) may lodge in person with the ERO objections as regards entries in the relevant provisional register **not later than 25 June in a non DC election year** (or 25 August in a DC election year). The procedures for making claims or objections are provided in the REO website (www.reo.gov.hk) during the public inspection period. On or before that date, an applicant whose name has not been recorded in the provisional register or an elector whose particulars have not been correctly recorded or an elector whose name has been included in the omissions list may lodge a claim in person with the ERO in respect of the entry or any omission concerning himself/herself/itself. To facilitate a person imprisoned or held in custody by a law enforcement agency to make such an objection or claim, he/she is allowed to deliver a notice of objection or claim to the ERO by post. Cases of objections and claims will be referred to the Revising Officer for consideration. The Revising Officer, who is a judicial officer, will rule on each objection or claim and decide on the inclusion, exclusion or correction of the entry concerned in the relevant final register. [S 34 of the LCO and Part VI of the EAC (ROE) (FCSEC) Reg] *[Amended in January 2010 and June 2016]*

The Final Register

3.32 The final register for FCs will be published **not later than 25 July in a non DC election year** (no later than 25 September in a DC election year) [s 38(1) of the EAC (ROE) (FCSEC) Reg]. It will include the entries in the relevant provisional register with the updated names and addresses of electors who have applied to alter their particulars, and the names and addresses of those who were subject to a notice of objection or claim as updated and corrected to reflect the decisions of the Revising Officer [ss 33(10)(a) and 35(1) of the EAC (ROE) (FCSEC) Reg]. The ERO will also take the opportunity to delete those entries of electors who are known to have died and to correct any mistakes in the relevant provisional register. The final register may also contain notations to show if a person registered for a GC is also registered in a FC. The final register for FCs shall remain valid until the publication of the relevant final register in the following year. The final register in force is available for public inspection at the REO and certain DOs. Upon request by a person imprisoned or held in custody by a law enforcement agency, the ERO may make available at a penal institution or the premises of a law enforcement agency as the case may be a copy of the final register for his/her inspection if the ERO considers it appropriate to do so. The ERO may require persons who want to inspect the final register to produce an identity document and complete a form furnished by him/her. [S 38(3) and (4A) of the EAC (ROE) (FCSEC) Reg] *[Amended in January 2010 and June 2016]*

IMPORTANT :

Information relating to a person contained in any register of electors or in any extract of any register of electors **can only be used for election-related purposes** under the electoral legislation. Any **abuse** or **misuse** of such information is an **offence** and will be liable to a fine at level 2 (\$5,000) and to imprisonment for 6

months [s 42(3) of the EAC (ROE) (FCSEC) Reg].

PART III : THE VOTING SYSTEMS FOR FUNCTIONAL CONSTITUENCIES

3.33 Different voting systems apply to elections of different FCs, namely,

- (a) for the 4 SFCs referred to in para. 3.12 above (items 1 to 4 of Appendix B), the preferential elimination system of voting [s 50(2) of the LCO];
- (b) for the DC (second) FC (item 29 of Appendix B), the list system of proportional representation [s 49(2) of the LCO]; and *[Added in June 2012]*
- (c) for the 24 ordinary FCs (items 5 to 28 of Appendix B), the first past the post voting system [s 51(2) of the LCO].

The Preferential Elimination System for the 4 SFCs

3.34 For each of the 4 SFCs, an elector is entitled to cast a single vote. The vote is transferable amongst the candidates nominated for the election, with the elector marking his/her preference or preferences for those candidates on the ballot paper against one or more of those candidates in descending order. In order to be elected, a candidate must obtain an absolute majority of the valid votes. If no candidate obtains an absolute majority of the votes at a particular stage of the counting of votes, the candidate with the least number of votes is to be eliminated at that stage, and that candidate's votes are to be transferred to the candidates then remaining in accordance with the next available preferences marked on the ballot papers. This process is to continue until one candidate

obtains an absolute majority over the other candidate or candidates then remaining. [S 50 of the LCO] If, after the counting of votes is finished but before the result of an election of a FC is declared, proof is given to the satisfaction of the RO that the candidate who was successful at the election has died or is disqualified from being elected, that RO must not declare that candidate as elected and must publicly declare that the election has failed [ss 46A(3) and 50(8) of the LCO]. Details of how the votes are to be counted are set out in **Appendix C**.

The First Past the Post Voting System for the 24 Ordinary FCs

3.35 An elector of each of the 24 ordinary FCs is entitled to vote for as many candidates as there are vacancies and no more. The candidate who obtains the greatest number of votes will be elected, followed by the next candidate who has the next greatest number of votes, and so on, until all the vacancies are filled. [S 51(2), (3) and (4) of the LCO] Out of the 24 ordinary FCs, only the Labour FC has 3 seats to be filled and electors of that ordinary FC can therefore vote for up to 3 candidates. In each of the remaining 23 ordinary FCs, only 1 seat is to be filled and the elector can only vote for 1 candidate. In the event that more than 1 candidate has the equal highest number of votes, the RO will have to draw lots to determine which one of these candidates should be elected to fill the vacancy [s 51(6) of the LCO].

3.36 When the successful candidate has to be determined by the drawing of lots, 10 table-tennis balls each marked with a number from 1 to 10 will be put into an empty opaque bag, to be provided by the REO. Each candidate is to draw 1 ball from the bag. The number marked on the ball should be noted by the RO and the ball should be put back into the bag. The other candidate(s) will draw in the same way. The RO would draw the lot on behalf of the candidate if the candidate is absent at the time of drawing lots. The candidate on whom the lot falls is to be returned at the election:

- (a) Where there is only 1 vacancy to be filled and there are 2 candidates, the candidate who draws the larger number from 1 to 10 will be the winner. 1 is the smallest number and 10 is the largest number.
- (b) Where there is only 1 vacancy to be filled and there are more than 2 candidates, if in the first draw, the numbers drawn by the candidates are different, then the candidate who draws the largest number will win. If, on the other hand, 2 or more of the candidates have drawn the same larger number and the remaining candidate(s) has/have drawn a smaller number, there must be a second draw. As the system of voting for the election is “first past the post”, only those candidates who have drawn the same larger number in the first draw will participate in the second draw.
- (c) Where there are 3 candidates having an equal number of votes and there are only 2 vacancies to be filled, if the 3 candidates have obtained respectively the largest, the larger and the smallest numbers, the 2 candidates who have obtained the largest and the larger numbers should be successful in getting the 2 vacancies, and the remaining candidate will fail. If the 3 candidates have obtained respectively 2 larger equal and 1 smaller numbers, then again the 2 candidates who have obtained the larger equal numbers will be the winners to fill the 2 vacancies. If the 3 candidates have obtained respectively a larger and 2 equal smaller numbers, the candidate who has obtained the larger number will be successful and the remaining 2 candidates will participate in a second draw. The same principle will apply where there are more than 3 candidates having an equal number of votes and there are 3 vacancies to be filled as in the case of the Labour FC.

The List System of Proportional Representation for the DC (second) FC

3.37 The electors of the DC (second) FC must only vote for 1 list of candidates (as shown on the ballot paper) and not for an individual candidate [s 49(3) of the LCO]. The 5 members of the DC (second) FC will be returned by the list system of proportional representation. For details on the voting system of the list system of proportional representation, please refer to Part III of Chapter 2. *[Added in June 2012]*

3.38 As soon as practicable after the result of the elections has been determined, the RO should publicly declare the successful candidate as elected.

Death or Disqualification of a Candidate for FC

3.39 In the case of a FC other than DC (second) FC, para. 3.40 to 3.42 apply. *[Added in June 2016]*

3.40 If the death or disqualification of a candidate is proved to the satisfaction of the RO before the election day but after the RO has decided that the candidate is validly nominated, the RO must, as soon as practicable, publicly declare that the proceedings for the election for that constituency are terminated. [S 42C of the LCO] *[Added in June 2016]*

3.41 In the event that on the polling day but before the close of poll for the election, proof is given to the satisfaction of the RO that a validly nominated candidate has died or has been disqualified from being elected, the RO should publicly declare that the proceedings for the election for the constituency are terminated. The declaration is to be made by a notice displayed in a prominent place outside each polling station of the relevant constituency and published in the Gazette as soon as practicable. [S 46A(1) of the LCO and s 97(1) of the EAC (EP) (LC) Reg] *[Added in June 2016]*

3.42 If after the close of poll, proof is given to the RO's satisfaction that a candidate for a constituency has died or has been disqualified from being elected, the RO should complete the counting of votes. After the counting of votes is finished, if the candidate concerned is found to be successful at the election, the RO should not declare that candidate as elected and should declare that the election has failed or has failed to the extent that the number of candidates returned at the election was less than the number of members to be returned. [Ss 46A(2), (3) and 51(8) of the LCO and s 83(2)(a) and (b)(ii) of the EAC (EP) (LC) Reg] *[Amended in June 2016]*

3.43 In the case of DC (second) FC, the voting arrangement set out in paras. 2.28 to 2.30 for GCs would equally apply. *[Added in June 2016]*

CHAPTER 4

NOMINATION OF CANDIDATES

PART I : ELIGIBILITY AND DISQUALIFICATION FOR NOMINATION

4.1 The law governing the eligibility for and disqualification from nomination of candidates for the LegCo election is contained in the LCO. The procedure for nomination of candidates for the LegCo election is provided in the EAC (EP) (LC) Reg and EAC (NAC) (LC) Reg made by the EAC. *[Amended in October 2007 and June 2016]*

Eligibility

4.2 To be eligible for nomination as a candidate at an election for a GC, a person must:

- (a) be 21 years of age or over;
- (b) be both registered and eligible to be registered as an elector for a GC;
- (c) not be disqualified from being elected by virtue of s 39 of the LCO [see para. 4.5 below];
- (d) have ordinarily resided in Hong Kong for the 3 years immediately preceding the date of his/her nomination; and
- (e) be a Chinese citizen who is a permanent resident of Hong Kong with no right of abode in any country other than the People's

Republic of China.

[S 37(1) of the LCO] *[Amended in June 2016]*

4.3 To be eligible for nomination as a candidate at an election for a FC, a person must:

- (a) satisfy para. 4.2(a) to (e) above, save that for the following 12 FCs, para. 4.2(e) does not apply, namely,
 - (i) Legal FC,
 - (ii) Accountancy FC,
 - (iii) Engineering FC,
 - (iv) Architectural, Surveying, Planning and Landscape FC,
 - (v) Real Estate and Construction FC,
 - (vi) Tourism FC,
 - (vii) Commercial (first) FC,
 - (viii) Industrial (first) FC,
 - (ix) Finance FC,
 - (x) Financial Services FC,
 - (xi) Import and Export FC,
 - (xii) Insurance FC;
- (b)
 - (i) be both registered and eligible to be registered as an elector for the relevant FC (other than the DC (second) FC); or
 - (ii) in the case of a FC other than the DC (first) FC and the DC (second) FC, satisfy the RO for the constituency that he/she has a substantial connection with that FC; and
- (c) in the case of the DC (first) FC and the DC (second) FC, is a

member of any DC established under the District Councils Ordinance (Cap 547) (“DCO”) who is elected under Part V of that Ordinance.

[S 37(2) and (3) of the LCO] *[Amended in June 2012 and June 2016]*

4.4 A person is considered to **ordinarily reside in Hong Kong** when he/she habitually and normally lives there lawfully for a settled purpose, apart from temporary and occasional absences such as holidays and absence abroad for studying purposes. Each case has to be examined upon its own facts. Matters like the length of the person’s absence, the reason for his/her absence, the location of the home of him/her, his/her spouse, children and parents and his/her maintenance of connections with Hong Kong are all relevant factors. In case of doubt, a prospective candidate should consult his/her independent legal adviser. In a LegCo general election, a candidate may also seek the advice of the NAC. [see paras. 4.7 to 4.13 below] *[Amended in June 2016]*

Disqualification

4.5 A person is disqualified from being nominated as a candidate at an election, and from being elected as a Member, if he/she:

- (a) is a judicial officer, or a prescribed public officer⁴;

⁴ A prescribed public officer means any of the following:

- (a) the Chairman of the Public Service Commission;
- (b) the Commissioner and Deputy Commissioner of the ICAC and the holder of any other office under the ICAC Ordinance (Cap 204);
- (c) the Ombudsman and the holder of any appointment under s 6 of The Ombudsman Ordinance (Cap 397);
- (d) a member of the EAC;
- (e) the chief executive of the Monetary Authority and any member of the senior management of that Authority, including divisional heads, executive directors, managers and counsel employed by that Authority;
- (f) the Privacy Commissioner for Personal Data and any person employed or engaged by him/her under the Personal Data (Privacy) Ordinance (Cap 486);
- (g) the Chairperson of the Equal Opportunities Commission and any person employed or whose services are engaged by the Commission under the Sex Discrimination Ordinance (Cap 480); or
- (h) any person holding an office, whether permanent or temporary, in a government department or bureau and employed in the department or bureau.

- (b) is an officer of the LegCo or a member of staff of The LegCo Commission;
- (c) has, in Hong Kong, or any other place, been sentenced to death or imprisonment (by whatever name called), and has not either served the sentence or any substitute sentence or received a free pardon⁵;
- (d) has been convicted of treason;
- (e) on the date of nomination, or of the election, is serving a sentence of imprisonment;
- (f) is or has been convicted, within 5 years before the polling day,
 - (i) of any offence in Hong Kong or in any other place, the sentence for which is imprisonment (suspended or not) for not less than 3 months;
 - (ii) of having engaged in corrupt or illegal conduct in contravention of the ECICO;
 - (iii) of any offence against Part II of the Prevention of Bribery Ordinance (Cap 201) (“POBO”); or
 - (iv) of any offence prescribed by the regulations made by the EAC;

⁵ The Court of First Instance delivered written judgment on 21 June 2012 on *Wong Hin Wai & another v Secretary for Justice* (HCAL 51 & 54/2012) and declared section 39(1)(b) of the LCO to be unconstitutional. On 12 July 2012, the Government announced its decision not to appeal against the judgment. The future LegCo Election will be organised in accordance with the prevailing electoral laws. Any person who would like to be nominated as a candidate for LegCo Election and is doubtful about his/her eligibility for nomination may seek independent legal advice, and in a LegCo general election, may also apply to the NAC appointed by the EAC for advice where appropriate.

- (g) is ineligible or disqualified because of operation of the LCO or any other law;
- (h) is a representative or a salaried functionary of the government of a place outside Hong Kong;
- (i) is a member of any national, regional or municipal legislature, assembly or council of any place outside Hong Kong, other than a people's congress or people's consultative body of the People's Republic of China, whether established at the national level or local level;
- (j) is an undischarged bankrupt or, within the previous 5 years, has either obtained a discharge in bankruptcy or has entered into a voluntary arrangement within the meaning of the Bankruptcy Ordinance (Cap 6) with the person's creditors, in either case without paying the creditors in full; *[Amended in July 2008]*
- (k) is found for the time being to be incapable, by reason of mental incapacity, of managing and administering his/her property and affairs under Part II of the Mental Health Ordinance (Cap 136) ;
or
- (l) at a by-election, has resigned or was taken to have resigned from office as a Member within the 6 months ending on the date of the by-election and no general election was held after the relevant notice of resignation or notice of non-acceptance took effect.
[Added in June 2016]

[S 39(1), (2) and (2A) of the LCO] *[Amended in July 2008 and June 2016]*

4.6 A person is also disqualified from being elected as a Member for

a FC (other than DC (first) FC and DC (second) FC) if, since the end of the nomination period, the person has ceased to have a substantial connection with the constituency [s 39(4) of the LCO]. *[Amended in June 2012]*

PART II : NOMINATIONS ADVISORY COMMITTEES

4.7 The EAC has the power to appoint NACs to provide advice, on request, to prospective candidates and ROs on the candidates' eligibility for nomination [s 3 of the EAC (NAC) (LC) Reg]. Each of these NACs is in the charge of either a Senior Counsel or a legal practitioner of not less than 10 years standing in accordance with established practice who, in the opinion of the EAC, is unconnected to any candidate or political organisation in Hong Kong, independent and impartial. *[Amended in October 2007]*

NAC's Service to Candidates [S 5 of the EAC (NAC) (LC) Reg]

4.8 NAC's service will be provided to candidates **only at a LegCo general election**. During a period to be specified by the EAC [s 3(4) of the EAC (NAC) (LC) Reg] – which normally ends 1 day before the commencement of the nomination – a prospective candidate may apply, by completing a specified form obtainable from the REO or from any DO, for the advice of the NAC as to whether he/she is eligible to be, or is disqualified from being, nominated as a candidate at the LegCo general election. He/She may make only 1 application in respect of the GC election and 1 application in respect of a particular FC election. While a prospective candidate may apply for advice only once in respect of a particular FC, he/she may apply for advice in respect of more than 1 FC. [S 5(6) and (9) of the EAC (NAC) (LC) Reg] *[Amended in June 2016]*

4.9 The completed application must be:

- (a) sent to the Chief Electoral Officer (“CEO”) by post or facsimile transmission so as to be received by him/her; or
- (b) served on the CEO personally,

on or before the deadline for application to be specified by the EAC.
[S 5(4) of the EAC (NAC) (LC) Reg]

4.10 An NAC may, before giving its advice, request the applicant to make available to it within a specified period any information, particulars and evidence relating to his/her intended candidature. The NAC may also request the applicant to present himself/herself before it at a specified time and place to assist it in the consideration of the application. The applicant may, at the specified time and place, make representations to the NAC personally or through any person authorised by him/her in writing for the purpose. [S 5(12) and (13) of the EAC (NAC) (LC) Reg]

4.11 Where an applicant does not make available any information, particulars or evidence as requested by the NAC, or fails to present himself/herself before the NAC in response to a request, the NAC may:

- (a) refuse to consider the application or to give any advice on it; or
- (b) give qualified advice on the application having regard to either or both of the following:
 - (i) the fact that any information, particulars or evidence, or where appropriate, all of them, were not available to it;
 - (ii) the failure of the applicant to present himself/herself before the NAC.

[S 5(14) of the EAC (NAC) (LC) Reg]

4.12 The NAC's advice to an applicant, including a decision to refuse to consider an application or to give advice, will be in writing and will be sent to the applicant not later than a date to be specified by the EAC [s 5(15) of the EAC (NAC) (LC) Reg].

4.13 Any advice given by an NAC or a refusal to give any such advice does not preclude a person from seeking nomination as a candidate in an election or proceeding with a nomination, if he/she so wishes [s 9 of the EAC (NAC) (LC) Reg]. *[Amended in July 2008]*

NAC's Service to ROs

4.14 NAC's service will be provided to ROs at both LegCo general elections and by-elections. During the period from the commencement until up to 1 day after the end of the nomination period, ROs may seek the advice of an NAC, where they consider necessary, on the eligibility for nomination of the candidates who have submitted their nominations. Such application must be in writing and made to the NAC through the CEO. The NAC will, not later than a date specified by the EAC, advise the RO concerned as to whether the candidate concerned is eligible to be nominated. [S 6 of the EAC (NAC) (LC) Reg]

4.15 The RO is required, in making a decision as to whether a particular candidate is validly nominated in respect of the constituency for which he/she seeks nomination, to have regard to any advice given by an NAC on that candidate [s 17 of the EAC (EP) (LC) Reg and s 6(5) of the EAC (NAC) (LC) Reg]. The decision on the validity of nomination, however, remains with the RO alone [s 6 of the EAC (NAC) (LC) Reg and s 92(1) and (3)(a) of the EAC (EP) (LC) Reg].

PART III : WHEN AND HOW TO NOMINATE

When to Nominate

4.16 Nominations may be made during the **nomination period** specified in the Notice of Election published in the Gazette [ss 4, 5 and 7 of the EAC (EP) (LC) Reg]. An election timetable will be provided to each candidate by the RO for the relevant constituency. The ROs shall receive nominations during the ordinary business hours on each working day (i.e. any day other than a general holiday) in the nomination period from 9 am to 5 pm on Monday to Friday, and from 9 am to 12 noon on a Saturday. **Candidates are well advised to submit their nominations in good time before the end of the nomination period to allow time for any errors in their nomination forms to be corrected.** *[Amended in October 2007 and June 2016]*

How to Nominate

4.17 Nomination forms specified by the EAC are available from any DO or from the REO, or can be downloaded from the website of the REO (<http://www.reo.gov.hk>). *[Amended in October 2007]*

4.18 The nomination form comprises:

(a) **The Nomination**

- (i) In respect of a **GC** election, the nomination is a list containing either the names of 2 or more proposed candidates contesting the election of the particular GC as a group with their names ranked in the order of priority of the group, or the name of a single proposed candidate. The nomination must be subscribed by **100 registered**

electors (other than the candidates) of that particular GC assenting to the nomination and the number of persons that may subscribe a nomination shall not be more than 200 [s 7(1)(a) and (aa) of the LC Subscribers & Deposit Reg]. An elector may subscribe only 1 nomination as regards a particular GC election [s 7(1)(b) of the LC Subscribers & Deposit Reg]. Under s 38(4A) of the LCO, after a nomination has been submitted to an RO, the order in which the names of proposed candidates appear in the list cannot be altered, no other name of any proposed candidate can be added to the list, and names already on the list cannot be deleted. [See, however, para. 4.36 below in the case of withdrawal.]

- (ii) In respect of a candidate of a traditional **FC**, it must be subscribed by **10 registered electors** (other than the candidate) and the number of persons that may subscribe a nomination shall not be more than 20 [s 7(2)(a) and (aa) of the LC Subscribers & Deposit Reg]. An elector may subscribe any number of nomination forms up to the number of seats in any FC [s 7(2)(b) of the LC Subscribers & Deposit Reg]. Thus, an elector of the Labour FC may subscribe up to 3 nominations as there are 3 vacancies to fill in that FC. For other traditional FCs, with 1 seat each, an elector may only subscribe 1 nomination. *[Amended in June 2012]*

In any of the above cases about traditional FCs, **the subscribing elector must be registered for the GC or the FC concerned**, as the case may be. In other words, **an elector** in respect of a GC and a traditional FC is entitled to **subscribe only 1 nomination regarding his/her own**

GC, and any number of nominations up to the number of vacancies regarding his/her traditional FC. Where the number of persons subscribing a nomination has exceeded the required number (i.e. 100 for a GC election and 10 for a FC election), any surplus over the required number of qualified subscribers will be regarded as not having subscribed the nomination concerned [s 7(2C) of the LC Subscribers & Deposit Reg]. In this case, the elector may subscribe another nomination instead. If the nomination subscribed by an elector has been held to be invalid, or the candidate or all the nominees on a nomination list has/have withdrawn his/her/their nomination, the elector may subscribe another one instead before the end of the relevant nomination period, and his/her signature shall not be inoperative on that other nomination form. Under this scenario, if he/she subscribes more than 1 nomination form in contravention of the regulations, his/her signature shall be operative only on the first one delivered [s 7(3)(c) of the LC Subscribers & Deposit Reg]. *[Amended in June 2012]*

- (iii) In respect of an election for **the DC (second) FC**, the nomination is a list containing either the names of 2 or more proposed candidates contesting the election of the same FC as a group with their names ranked in the order of priority of the group, or the name of a single proposed candidate. The nomination must be subscribed by **15 registered electors** (other than the candidate(s)) **of the DC (first) FC** [s 7(1A) of the LC Subscribers & Deposit Reg]. In accordance with s 7(3A) and (3B) of the LC Subscribers & Deposit Reg, if an elector of the DC (first) FC subscribes the nomination paper of any persons seeking

nomination in respect of the DC (first) FC and the DC (second) FC and both the nomination papers of the DC (first) FC and the DC (second) FC have been delivered, his/her signature shall be operative only on the first nomination paper delivered. In other words, an elector of the DC (first) FC shall **subscribe 1 nomination only for either** a candidate of the DC (first) FC election **or** a candidate list of the DC (second) FC election. *[Added in June 2012]*

IMPORTANT :

A candidate who submits a nomination form on the last few days of the nomination period is advised to include more than the required number of subscribers for his/her nomination to avoid the risk of invalidation of the nomination should one or more of the subscribers be subsequently found not to be qualified as subscribers. A candidate should use his/her best endeavour to ensure that the electors subscribing his/her nomination form are eligible and have not subscribed another nomination previously. Each elector subscribing a nomination shall sign the nomination form **personally**. *[Amended in October 2007 and June 2016]*

No unlawful means shall be used to procure an elector to subscribe or not to subscribe a nomination. Intimidation is an offence under s 24 of the Crimes Ordinance (Cap 200), liable to a fine and to imprisonment for 2 years on summary conviction or imprisonment for 5 years on conviction upon indictment. Bribery is also a corrupt conduct liable to a fine or to imprisonment. *[Added in October 2007 and amended in June 2012]*

Candidates are also required to observe Principle 4 of Schedule 1 to the Personal Data (Privacy) Ordinance (Cap 486) (“PD (P) O”) in safeguarding the personal data of subscribers held for the nomination form. They should take all practicable steps to ensure that the aforesaid personal data are protected against unauthorised or accidental access, processing, erasure, loss or use.
[Added in June 2012 and amended in June 2016]

(b) The Candidate’s Consent to Nomination and Declarations

This must be completed and signed by the candidate and attested by a witness. The candidate must sign and make the following **declarations** and promissory oath:

- (i) a declaration to the effect that the candidate will uphold the Basic Law and pledge allegiance to the HKSAR;
- (ii) a declaration as to the candidate’s nationality and as to whether or not he/she has a right of abode in a country other than the People’s Republic of China;
- (iii) a promissory oath given by the candidate to the effect that, if elected, he/she will not do anything during his/her term of office that results in his/her disqualification, including mainly those set out in para. 4.5 above, plus becoming a member of any armed forces;
- (iv) a declaration to the effect that the candidate, or each candidate in the case of a list for the GC/DC (second) FC, is eligible to be nominated as a candidate for the constituency concerned; is not disqualified from being so nominated; and consents to being so nominated. In the case of a list for the GC/DC (second) FC, each candidate

must also declare his/her consent to the order of priority in which the names of candidates appear on the nomination list; and *[Amended in June 2012]*

- (v) a declaration to the effect that the candidate, or each candidate in the case of a list for the GC/DC (second) FC has ordinarily resided in Hong Kong for the 3 years immediately preceding the date of his/her nomination. *[Amended in June 2012]*

[Ss 37 and 40 of the LCO and ss 10(4) and (5) and 11(4) and (5) of the EAC (EP) (LC) Reg]

IMPORTANT :

No person shall be nominated in an election as a candidate for more than 1 constituency [s 41 of the LCO]. When a person submits his/her nomination form, he/she must have withdrawn all his/her other prior nominations, if any. He/She is required to make a declaration (contained in the specified form) that either he/she has not been nominated before for any other constituency in the election, or if he/she has been so, he/she has withdrawn all those prior nominations. Where a candidate stands nominated [see para. 4.26 below], any subsequent nominations of his/hers will be rejected as invalid.

In the nomination form, a candidate may choose to state his/her occupation and/or political affiliation for public information if he/she so prefers. If the candidate mentions the name of any organisation when stating his/her political affiliation, he/she must seek the consent of the organisation concerned beforehand. Candidates should make sure that their nomination forms are properly completed before submission. *[Amended in October 2007, June*

2012 and June 2016]

4.19 Each nomination form must be submitted to the RO for the constituency concerned together with the payment of an appropriate election deposit [see Part IV of this chapter for details]. The RO may refuse to accept any nomination form where there is a material alteration of its content.

4.20 The completed nomination form must be delivered with the RO for the constituency concerned by the candidate, and in case of a list of candidates by one of the candidates, **in person** during ordinary business hours (i.e. 9 am to 5 pm from Monday to Friday, and from 9 am to 12 noon on a Saturday) on a working day (i.e. any other day other than a general holiday) in the nomination period. In the case of nominations for traditional FC elections, the CEO may, in exceptional circumstances, e.g. the nominee's temporary absence from Hong Kong or incapacity due to illness, authorise other form of delivery of the nomination form to the RO [s 11(14) of the EAC (EP) (LC) Reg]. *[Amended in June 2012 and June 2016]*

4.21 The RO will also make available copies of the nomination forms for public inspection free of charge at his/her office during ordinary business hours until the relevant notice of the election result is published [s 14 of the EAC (EP) (LC) Reg]. Should the RO decide that a nomination is invalid (see Part V below), he/she is required to endorse on the nomination form his/her decision and the reasons for it [s 19(1) of the EAC (EP) (LC) Reg]. *[Added in June 2016]*

False Declarations

4.22 A candidate who knowingly and wilfully makes a statement which is false in a material particular in the declaration in the nomination form shall be guilty of an offence under the Crimes Ordinance (Cap 200) and shall be liable to a fine and to imprisonment for 2 years. Under s 103 of the EAC

(EP) (LC) Reg, a person who knowingly makes a false statement in a material particular or recklessly makes an incorrect statement in a material particular or omits a material particular in an election-related document commits an offence and shall be liable to a fine at level 2 (\$5,000) and to imprisonment for 6 months, which is a prescribed offence with the same disqualifying effect as conviction of a corrupt or illegal conduct under the ECICO (as described in paras. 16.66 and 17.33 of the Guidelines). *[Amended in October 2007 and June 2016]*

PART IV : ELECTION DEPOSIT

Payment of Election Deposit

4.23 Each nomination form must be presented with the payment of an election deposit, in cash, cashier order or by cheque, in such amount as prescribed by regulation [ss 40(3) and 82(2)(b) of the LCO]. The following election deposits are prescribed by s 2 of the LC Subscribers & Deposit Reg:

- | | | |
|-----|---|----------|
| (a) | for all the candidates on a GC list | \$50,000 |
| (b) | for a candidate of a traditional FC | \$25,000 |
| (c) | for all the candidates on a list for the DC (second) FC | \$25,000 |

[Amended in June 2012]

4.24 A nomination form will not be received by the RO unless it is accompanied by the required sum of election deposit.

IMPORTANT :

Candidates are encouraged to pay their election deposit by cash or cashier order although they may pay by crossed cheque. In the event that a cheque is dishonoured, the nomination will be ruled invalid unless the sum of deposit is made good before the end of the nomination period. Candidates must note that, in the case of dishonoured cheque, the RO may not be able to advise the candidate(s) concerned in good time to rectify the situation before the end of the nomination period. Therefore, in order to avoid the risk of invalidation of the nomination due to dishonoured cheque, candidates are strongly advised to submit the election deposit in cash or cashier order.

[Amended in June 2012]

Return of Election Deposit

4.25 The deposit will be returned to the candidate (or in the case of a list of candidates, the person who has lodged the deposit on behalf of the list) if:

- (a) he/she is not validly nominated (and in the case of a list of candidates, if all the candidates on the list are not validly nominated);
- (b) his/her nomination is withdrawn (and in the case of a list of candidates, if all the candidates on the list have withdrawn their nomination);
- (c) after his/her nomination is confirmed valid for the election, he/she has died or is disqualified from being nominated before the date specified for holding the election (and in the case of a list

of candidates, if all the candidates on the list have died or are disqualified from being nominated); *[Amended in June 2016]*

- (d) in the case of a list of candidates, the list is rejected by the RO after he/she has struck out from the list all the names of candidates for any one, or any combination, of the reasons stated in items (a), (b) or (c) above;
- (e) the election is terminated;
- (f) he/she is elected (and in the case of a list of candidates, if the first ranked candidate on the list is elected);
- (g) in the case of a GC or DC (second) FC or one of the ordinary FCs, he/she or the list of candidates secures in his/her/their favour not less than 3% of the total number of ballot papers containing valid votes received in that constituency; or
- (h) in the case of one of the 4 SFCs, he/she secures in his/her favour not less than 3% of the total number of ballot papers containing valid first preference votes received in that constituency.

The deposit will be forfeited if none of the above conditions is satisfied. [For details, see ss 3 and 4 of the LC Subscribers & Deposit Reg.] *[Amended in June 2016]*

PART V : VALIDITY OF NOMINATIONS

[Ss 16, 17, 18 and 21 of the EAC (EP) (LC) Reg]

4.26 The RO will make a decision as to the validity of a nomination as soon as practicable after receipt of the nomination form and will publish a

notice stating which persons are validly nominated as candidates within 14 days after the end of the nomination period [s 42A of the LCO and s 21(1) of the EAC (EP) (LC) Reg].

4.27 Where the RO has doubts as to whether or not a particular candidate is eligible to be nominated, he/she may apply to an NAC for advice [see para. 4.14 above]. *[Amended in June 2016]*

4.28 Where a nomination appears to the RO to be invalid because of some errors which can be corrected within the nomination period, the RO will, if practicable, give the candidate a reasonable opportunity of correcting the errors before making a decision that the nomination is invalid. For example, if the entitlement of any subscriber is in doubt, a prospective candidate may be allowed to make a substitution as soon after the submission of his/her nomination form as practicable. However, no substitution for any subscriber or re-submission of a nomination form will be accepted after the end of the nomination period.

4.29 A nomination may be ruled invalid if any errors on the nomination form are not corrected by the end of the nomination period.

4.30 The RO may require such additional information from a candidate as he/she considers necessary to satisfy himself/herself as to the validity of the nomination.

4.31 A nomination will not be valid unless it contains all the information and signatures required to be shown on the nomination form or other information required by the RO and the candidate has made the declarations and oath referred to in para. 4.18(b) above. *[Amended in June 2012]*

4.32 The RO may decide that a nomination is invalid only where:

- (a) the number or qualifications of the subscribers fall short of the requirements under s 7 of the LC Subscribers & Deposit Reg;
- (b) the nomination form, including the nomination and declarations and oath, has not been completed or signed as required by s 40 of the LCO and ss 10 and 11 of the EAC (EP) (LC) Reg;
- (c) he/she is satisfied that the candidate or all the candidates on a list of candidates is/are not eligible to be, or is disqualified from being, nominated as a candidate, having regard to any advice given by the NAC to an application made by him/her or by that candidate [see paras. 4.15 and 4.27 above]; *[Amended in June 2012]*
- (d) the candidate or all the candidates on a list of candidates has/have been nominated for another constituency in the same election and the RO is not satisfied that he/she/they has/have withdrawn that candidature; *[Amended in July 2008 and June 2012]*
- (e) the cheque for the payment of the election deposit of the candidate is dishonoured and has not been made good before the end of the nomination period;
- (f) he/she is satisfied that the candidate has passed away; or
- (g) the nomination form is not duly lodged within the nomination period [see paras. 4.16 and 4.20 above].

[Amended in July 2008, June 2012 and June 2016]

4.33 If, having decided that a candidate is validly nominated for election for a GC or the DC (second) FC but before the polling day, proof is given to the satisfaction of the RO that the candidate has died, he/she must publicly declare that the candidate has died and further declare which candidate is or candidates are validly nominated for that constituency. The RO does not have to make any such declaration if the candidate who has died is uncontested in the election for the relevant constituency and the RO has publicly declared that the candidate was duly elected. [S 42B(1), (2) and (3) of the LCO and s 22A of the EAC (EP) (LC) Reg] *[Amended in June 2012]*

4.34 If, having decided that a candidate is validly nominated for election for a GC or the DC (second) FC but before the polling day, proof is given to the satisfaction of the RO that the candidate is disqualified from being nominated as a candidate, the RO must vary the decision to the effect that the candidate is not validly nominated. He/She must then publicly declare his/her varied decision and which candidate is or candidates are validly nominated for that constituency. The RO does not have to vary his/her decision if the candidate who has been disqualified is uncontested for the relevant constituency and the RO has publicly declared that the candidate was duly elected [s 42B(4), (5) and (6) of the LCO and s 22B of the EAC (EP) (LC) Reg]. *[Amended in June 2012]*

4.35 If, after the end of the nomination period for an election for a traditional FC but before the polling day, proof is given to the satisfaction of the RO that the candidate who is validly nominated has died or is disqualified from being nominated as a candidate for the constituency, he/she must publicly declare that the proceedings for the election for that FC are terminated [s 42C of the LCO]. *[Amended in June 2012]*

PART VI : WITHDRAWAL OF CANDIDATURE

4.36 A candidate may withdraw his/her candidature only before the end of the nomination period. He/She should complete and sign a specified form entitled “Withdrawal of Candidature” and lodge it with the RO concerned [s 42 of the LCO and s 20 of the EAC (EP) (LC) Reg]. Where a candidate in a nomination list for a GC election or the DC (second) FC election has effectively withdrawn his/her candidature, the RO must strike out his/her name from the list and adjust the order of priority in which the names of other candidates appear on the list accordingly [s 38(6) of the LCO]. If, after the RO has determined that a nominee is validly nominated, but before the end of the nomination period, the RO becomes aware that the nominee has died or is disqualified from being nominated, the RO must strike out his/her name from the list and adjust the order of priority in which the names of other candidates appear on the list accordingly [s 38(6A) of the LCO]. After striking out a name from a list of candidates, the RO must not add the name of any other person to the list [s 38(12) of the LCO]. If no name remains on the list of candidates, the RO must reject the list [s 38(13) of the LCO]. *[Amended in June 2012]*

IMPORTANT :

It is an offence under ss 7 and 8 of the ECICO for a person to bribe, or to use or threaten to use force or duress against, a candidate to induce him/her to withdraw his/her candidature; and for a candidate to solicit or accept a bribe to withdraw his/her candidature.

PART VII : NOTICE OF VALID NOMINATIONS

4.37 The RO for the constituency concerned will publish a notice in

the Gazette within 14 days after the end of the nomination period, stating the name and the principal residential address of each of all the validly nominated candidates for the constituency, together with the number or the letter of the alphabet allocated by the drawing of lots to each candidate/list of candidates (please refer to para. 4.58) and, in the case of a FC, preceded by the code or the abbreviation assigned to the relevant FC as the case may be [s 21 of the EAC (EP) (LC) Reg]. These numbers or letters of the alphabet pertaining to candidates and lists of candidates will also be shown on the ballot paper. Each validly nominated candidate will be separately informed of the validity of all nominations of the same constituency. *[Amended in June 2012 and June 2016]*

PART VIII : PARTICULARS RELATING TO CANDIDATES ON BALLOT PAPERS

4.38 Under the PCBP (LC & DC) Reg, candidates may, **during the nomination period**, request the EAC to print specified particulars relating to candidates on ballot papers for use in LegCo elections. These particulars include registered names and emblems of prescribed bodies⁶, registered emblems of prescribed persons⁷, words indicating that a candidate is an independent candidate or a non-affiliated candidate, and personal photographs of candidates. *[Amended in October 2007]*

⁶ A prescribed body means a prescribed political body or a prescribed non-political body.

⁷ A prescribed person means a person that is registered in a final register of electors for GCs as compiled and published in accordance with the LCO and that is not disqualified from being so registered or from voting at an election.

Request to Print Particulars Relating to Candidates on Ballot Papers

Request by candidate for traditional FC or a sole candidate on nomination list in GC and DC (second) FC

4.39 A candidate for a traditional FC or a sole candidate on a nomination list in GC/DC (second) FC may request the EAC to print on a ballot paper his/her personal photograph and a choice of the following particulars -

- (a) the registered names and/or registered emblems relating to not more than 3 prescribed bodies (see paras. 4.40 and 4.44);
- (b) the registered emblem relating to the candidate; or
- (c) the registered names and/or registered emblems relating to not more than 2 prescribed bodies and the registered emblem relating to the candidate (see para. 4.40).

[S 3(2) and (3) of the PCBP (LC & DC) Reg]

In any case, the candidate can also choose the words “Independent Candidate” or “Non-affiliated Candidate” for printing on a ballot paper. *[Amended in October 2007, June 2012 and June 2016]*

4.40 A request must be made in the specified form and signed by the requestor. Where the subject of the request relates to 1 or more prescribed bodies, it must be accompanied by a written consent given, during the nomination period, by the body or each of the bodies in relation to the request. Where the subject of the request includes a photograph, it must be accompanied by the photograph with the name of the candidate shown on the back of the photograph. [S 3(4) of the PCBP (LC & DC) Reg] *[Amended in October 2007]*

Request by candidate on nomination list in GC/DC (second) FC with more than 1 candidate

4.41 A candidate on a nomination list with more than 1 candidate may request the EAC to print on a ballot paper a personal photograph of any 1 or more of the candidates on the list, and a choice of the following particulars –

- (a) the registered names and/or registered emblems relating to not more than 3 prescribed bodies (see para. 4.42);
- (b) the registered emblems relating to not more than 3 candidates on the nomination list concerned;
- (c) the registered names and/or registered emblems relating to 1 prescribed body and the registered emblem relating to not more than 2 candidates on the nomination list concerned; or
- (d) the registered names and/or registered emblems relating to 2 prescribed bodies and the registered emblem relating to one of the candidates on the nomination list concerned.

[S 4(2), (3) and (4) of the PCBP (LC & DC) Reg]

In any case, the candidate(s) can also choose the words “Independent Candidate” or “Non-affiliated Candidate” against the names of the corresponding candidates for printing on a ballot paper. *[Amended in October 2007 and June 2016]*

4.42 A request must be made in the specified form and signed by the requestor and all other candidates on the nomination list concerned. Where the subject of the request relates to 1 or more prescribed bodies, it must be

accompanied by a written consent given, during the nomination period, by the body or each of the bodies in relation to the request. Where the subject of the request includes one or more photographs, it must be accompanied by the photograph or photographs with the name of the candidate concerned shown on the back of each photograph. [S 4(5) of the PCBP (LC & DC) Reg] *[Amended in October 2007]*

Application for Registration of Name and Emblem

4.43 The particulars already registered with the EAC under the former Particulars Relating to Candidates on Ballot Paper (Legislative Council) Regulation are deemed to have been registered with the EAC in relation to both LegCo and DC elections. All subsequent registrations will be applicable to both LegCo and DC elections. *[Added in October 2007]*

Application by prescribed body for the registration of its name and emblem

4.44 Subject to the time frame for application as detailed in para. 4.48, a prescribed body intending to support a candidate in a LegCo election may at any time apply to the EAC for the registration of all or any of the following particulars:

- (a) the Chinese name of the body;
- (b) an abbreviation of the Chinese name of the body;
- (c) the English name of the body;
- (d) an abbreviation of the English name of the body;
- (e) an emblem of the body.

[S 8(1) of the PCBP (LC & DC) Reg]

4.45 An application must be made in the specified form and signed by the applicant. It should indicate that the applicant is a prescribed political body or a prescribed non-political body and that the applicant intends to consent to the subject of application being printed on a ballot paper as particulars relating to 1 or more persons as candidates. The application must also be accompanied by a copy of the certificate or document issued to the body by an authority or regulatory organisation that regulates the body under the laws of Hong Kong and showing the name of the body. [S 8(2) of the PCBP (LC & DC) Reg] *[Amended in October 2007]*

Application by prescribed person for the registration of his/her emblem

4.46 A prescribed person intending to run in a LegCo election may in accordance with the registration cycle apply to the EAC for the registration of an emblem of the person [s 9(1) of the PCBP (LC & DC) Reg]. *[Amended in June 2016]*

4.47 An application must be made in the specified form and signed by the applicant [s 9(2) of the PCBP (LC & DC) Reg]. *[Amended in October 2007]*

Timing of Application

4.48 Applications for registration may be submitted to the EAC for processing and approval. A register containing the particulars in respect of the registered names and emblems of prescribed bodies and registered emblems of prescribed persons, which have been approved by the EAC and published in the Gazette, is maintained by the CEO for public inspection. The register is updated annually to reflect any approved additions/deletions and only the approved particulars may be used by candidates in an election. The relevant cut-off date for the receipt of applications for processing and inclusion in the

register in each year is as follows:

- (a) 15 June in a year in which a DC ordinary election is to be held;
and
- (b) 15 April in any other years.

[S 2 of the PCBP (LC & DC) Reg] *[Amended in October 2007, July 2008, June 2012 and June 2016]*

Processing of Application

4.49 The EAC will process any application made by a prescribed body or a prescribed person:

- (a) if the application is made on or before the relevant cut-off date in a year, as soon as practicable after that date, and in any event within that annual registration cycle; or
- (b) if the application is made after the relevant cut-off date in a year, as soon as practicable after the relevant cut-off date of the next following annual registration cycle, and in any event within the next following annual registration cycle.

[S 11 of the PCBP (LC & DC) Reg] *[Amended in October 2007, July 2008 and June 2012]*

4.50 If the EAC is of the opinion that it may refuse to grant an application made by a prescribed body or a prescribed person, it must give the applicant a notice in writing. The applicant may, within 14 days after the notice is given, vary the application or make representations in writing to the EAC on why it should not refuse to grant the application [ss 12 and 13(1) and

(2) of the PCBP (LC & DC) Reg]. *[Amended in October 2007]*

4.51 If the EAC, having considered an application made by a prescribed body or a prescribed person, is of the opinion that it may grant the application, it will publish a notice in respect of the application in the Gazette:

- (a) specifying the name of the applicant and the subject of the application;
- (b) stating that the EAC may grant the application; and
- (c) inviting any person who objects to the granting of the application to make objection to the EAC in accordance with s 15 of the PCBP (LC & DC) Reg.

[S 14 of the PCBP (LC & DC) Reg] *[Amended in October 2007]*

4.52 Under s 15 of the PCBP (LC & DC) Reg, any person may, within 14 days after the publication of a notice in respect of an application in the Gazette, by notice in writing given to the EAC, object to the granting of the application. *[Amended in October 2007]*

4.53 In the event of an objection, the EAC will conduct a hearing. Under normal circumstances, a hearing will be held in public. However, a hearing may be held in private if it is in the interest of justice to do so. The EAC will make a decision on whether the application should be granted after hearing the representations and examining the relevant materials. [S 17 of the PCBP (LC & DC) Reg]

4.54 The EAC will, as soon as practicable after a decision is made to grant an application made by a prescribed body or a prescribed person, publish a notice in respect of the application in the Gazette specifying the name of the

applicant and the subject of the application. If a decision is made to refuse an application, the EAC will notify the applicant in writing of the EAC's decision with reasons for its refusal [s 19 of the PCBP (LC & DC) Reg]. *[Amended in October 2007]*

Registration and De-registration of Name, Emblem, etc.

4.55 A register of the relevant particulars in respect of the registered names and emblems of prescribed bodies and the registered emblems of prescribed persons is established and maintained by the CEO who makes the register available for inspection, free of charge, by members of the public during ordinary business hours at the REO [s 20 of the PCBP (LC & DC) Reg]. *[Amended in October 2007]*

4.56 The EAC may de-register the name, the abbreviation of the name and the emblem that is registered in relation to a prescribed body on the grounds that:

- (a) no request is made to print the subject of registration on ballot papers:
 - (i) in 2 consecutive LegCo general elections;
 - (ii) in 2 consecutive DC ordinary elections, one of which is held between such LegCo general elections; and
 - (iii) in any LegCo or DC by-election held between such LegCo general elections or DC ordinary elections;

or

- (b) the body ceases to exist.

[S 21(1) of the PCBP (LC & DC) Reg] *[Amended in October 2007]*

4.57 The EAC may also de-register the emblem that is registered in relation to a prescribed person on the grounds that:

- (a) no request is made to print the subject of registration on ballot papers:
 - (i) in 2 consecutive LegCo general elections;
 - (ii) in 2 consecutive DC ordinary elections, one of which is held between such LegCo general elections; and
 - (iii) in any LegCo or DC by-election held between such LegCo general elections or DC ordinary elections;

or

- (b) the person has died.

[S 21(2) of the PCBP (LC & DC) Reg] *[Amended in October 2007]*

PART IX : CANDIDATES' BRIEFING AND INTRODUCTION TO CANDIDATES

4.58 The EAC will conduct a briefing for all validly nominated candidates/lists of candidates on important matters related to the election. After the end of the nomination period, the RO will inform each validly nominated candidate/list of candidates of the date and time of the Candidates' Briefing. The RO will conduct a lots drawing session immediately after the briefing to allocate to each candidate/list of candidates a number or a letter of

the alphabet to be shown on the ballot paper; and a set of designated spots for displaying EAs (please refer to para. 8.31). *[Amended in June 2016]*

4.59 The REO will publish an **Introduction to Candidates**. The number or the letter of the alphabet of each candidate/list of candidates on the ballot paper allocated to him/her or the list by the drawing of lots will also be shown on the Introduction to Candidates, which will be mailed to the electors together with the poll cards before the polling day. Copies of the Introduction to Candidates will be made available in the Correctional Services Department (“CSD”) and other law enforcement agencies for electors imprisoned or held in custody. *[Amended in July 2008, January 2010 and June 2016]*

4.60 Candidates are free to make use of the Introduction to Candidates to promote their election platforms. Any candidate/list of candidates who so wishes should submit the following to the relevant RO **before the end of the nomination period**:

- (a) a duly completed grid paper affixing a colour photograph of the candidate which must be in a specified size and should be taken within the last 6 months; and
- (b) 2 additional copies of his/her photograph identical to the one affixed to the grid paper with his/her name label affixed on the back.

If a candidate/list of candidates does not submit the grid paper, the Introduction to Candidates will only show the name(s) and the number or letter allocated in respect of him/her/them, and “Relevant information has not been provided by the candidate/list of candidates” will be printed in the space provided for the election platform. *[Amended in October 2007, July 2008 and June 2016]*

4.61 The contents, nature and presentation of the candidates’ messages

in the Introduction to Candidates are exclusively the idea and work of the candidate(s) himself/herself/themselves. They will not be subject to alteration or editing by the REO unless they are considered to be indecent, defamatory, unlawful or contain information not relating to the direct promotion of the candidature of the candidate(s) concerned. *[Amended in July 2008 and June 2012]*

4.62 To assist persons with visual impairment to read the contents of the election platform in the Introduction to Candidates, the REO has put in place a mechanism for candidates to provide separately the typed texts of their messages therein. With these typed texts, the REO would prepare a text version of the Introduction to Candidates for uploading onto the dedicated website for the election. This text version would enable persons with visual impairment to read the contents of the document with the aid of a computer. If the candidate/list of candidates does not provide the typed text of the Introduction to Candidates, the website will only show his/her/their name(s) and the number/letter allocated with the remark that the candidate/list of candidates has not provided a text version of his/her/their election platform. The EAC appeals to all candidates to support this initiative and make use of this text version to communicate their electoral messages to persons with visual impairment. As a general principle, candidates should be sensitive to the needs of persons with disabilities and, in the course of their electioneering campaign, make their utmost efforts to ensure that persons with disabilities, irrespective of their different forms of disability, can have fair access to their electoral messages. *[Added in June 2016]*

CHAPTER 5

POLLING AND COUNTING ARRANGEMENTS

PART I : BEFORE THE POLL

5.1 For each of the 5 GCs, a number of polling stations situated within the GC will be designated. Dedicated polling stations⁸ will also be set up inside penal institutions or other suitable places. Registered electors and ARs of corporate electors who are imprisoned or held in custody by the law enforcement agencies on polling day will be allocated to vote at dedicated polling stations. The polling stations (including dedicated polling stations) will be used for polling for the GCs and the FCs (a combined polling arrangement (see para. 5.5 below)). The polling stations (other than small polling stations (see para. 5.2 below) and dedicated polling stations) will be converted to counting stations for counting the GC ballot papers. A central counting station will be set up for counting the FC ballot papers and any misplaced GC ballot papers found in FC ballot boxes at the central counting station. *[Amended in January 2010 and June 2012]*

5.2 The CEO must designate by notice in the Gazette place(s) as polling stations (including small polling stations and special polling stations⁹), dedicated polling stations, ballot paper sorting stations¹⁰ or counting stations at least 10 days before the polling day. The CEO may also designate the same place as a polling station and a counting station. He/She will designate a

⁸ A dedicated polling station means a place situated inside penal institutions or other suitable places at which registered electors, who are imprisoned or held in custody by the law enforcement agencies on polling day, will be allocated to vote.

⁹ A special polling station is one accessible to electors with mobility difficulty. (See also para. 5.12 below)

¹⁰ A ballot paper sorting station may be set up to sort GC ballot papers received from the dedicated polling stations according to each GC before they are delivered to the respective main counting stations for counting of votes.

polling station at which less than 500 electors are assigned to vote as a **small polling station**. He/She will designate a polling station (other than a small polling station or a dedicated polling station) as a **main counting station** for the purpose of counting the GC votes cast at the designated polling station, the small polling station(s) and/or the dedicated polling station(s). [Ss 2(6), 28(1), (1A), (1B), (1BA) and (1C) and 30 of the EAC (EP) (LC) Reg] The RO must, at least 10 days before the polling day, give notice in writing to each candidate of the place or places at which vote counting and where applicable, at which sorting of ballot papers received from the dedicated polling stations is to take place for the constituency contested by the candidates [ss 2(6), 65(2A), (3) and (5) of the EAC (EP) (LC) Reg]. *[Amended in July 2008, January 2010 and June 2016]*

5.3 An area outside the polling station will be designated as the No Canvassing Zone (“NCZ”) and No Staying Zone (“NSZ”), the boundaries of which will be determined by the RO. All candidates will be notified of these zones before the polling day [s 40 of the EAC (EP) (LC) Reg]. The RO may also authorise the Presiding Officer (“PRO”) to vary the NCZ or NSZ on the polling day [s 40(11A) of the EAC (EP) (LC) Reg]. [See Chapter 14] *[Amended in July 2008]*

5.4 A polling station for a GC is normally situated within the boundaries of the constituency, but where there are no suitable premises for use within the GC, polling stations may have to be designated in nearby areas outside the constituency. Where circumstances require, non-permanent structures may be designated as polling stations. The polling stations designated for the 5 GCs will be, as far as practicable, close to the principal residence of electors as shown on the final register, save for registered electors imprisoned or held in custody by the law enforcement agencies who will be assigned to vote at the appropriate dedicated polling stations. [S 30(4) and (4A) of the EAC (EP) (LC) Reg] *[Amended in January 2010]*

The Combined Polling Arrangements

5.5 Combined polling arrangements will be made for the convenience of all electors. Whether an elector is entitled to vote in a GC, a FC, or both GC and FC(s), he/she needs only to attend **1** polling station to cast all his/her votes. There are the following scenarios:

- (a) an elector who is only entitled to cast a GC vote: he/she will be allocated to a polling station designated for that GC or a dedicated polling station as appropriate for casting his/her GC vote;
- (b) a FC elector/AR of a corporate elector of one of the FCs: he/she will be allocated to the polling station designated for his/her GC or a dedicated polling station as appropriate, in which he/she can at the same time cast his/her GC vote and his/her FC elector vote or his/her FC AR vote; and
- (c) an elector of a FC who may be at the same time an AR of another FC: he/she will be allocated to the polling station designated for his/her GC or a dedicated polling station as appropriate, in which he/she can at the same time cast his/her GC vote, his/her FC vote as elector and his/her FC vote as AR.

[S 30(4) and (4A) of the EAC (EP) (LC) Reg] *[Amended in January 2010 and June 2012]*

5.6 Owing to the fact that combined polling arrangements are used, special arrangements regarding poll cards, ballot papers, cardboards and ballot boxes may be required, so as to help prevent confusion and mistake at polling, avoid breaking the secrecy of the vote, and facilitate sorting of ballot papers at

the count.

5.7 The **ballot papers** for each of the 5 GCs and each of the 29 FCs will be made easily distinguishable by way of one or more of the following ways, namely, size, colour, colour pattern and code. This will facilitate the issue of ballot papers at polling and the sorting of ballot papers at the count. The **poll card** (notifying the elector/AR of the polling station he/she must attend to cast his/her vote or votes) sent to the elector/AR shortly before the polling day will bear the same colour as that used for the cardboard referred to in para. 5.9 below, depending on the number and combination of ballot papers he/she is entitled to be issued to him/her in the polling station. *[Amended in June 2012]*

5.8 **Three types of ballot boxes** are provided in a polling station for receiving the GC ballot papers, the DC (second) FC ballot papers and the ordinary FCs/SFCs ballot papers (combined). *[Amended in July 2008 and June 2012]*

5.9 In order to ensure that no elector/AR will leave the polling station with any ballot paper, a **colour cardboard** will be given to him/her at the same time when ballot paper(s) are issued to him/her. The colour of the cardboard will depend on the number and combination of ballot papers that are issued to the elector according to his/her entitlement: **green** for an elector issued with 1 GC ballot paper only, **white** for one issued with 1 GC ballot paper and 1 DC (second) FC ballot paper, **red** for one issued with 1 GC ballot paper and 1 FC (other than DC (second) FC) ballot papers and **blue** for one issued with 1 GC ballot paper and 2 FC ballot papers. *[Amended in June 2012]*

[Please see **Appendix D** for details of the combined polling arrangements mentioned in the preceding 5 paragraphs.]

5.10 At least 10 days before the polling day, poll cards notifying electors/ARs of contested constituencies the date, time and place of the poll will be sent to their registered address or correspondence address (if applicable). To allow electors and ARs of corporate electors serving a sentence of imprisonment on the polling day to receive the poll cards as early as possible, the REO will send the poll cards to the prisons where the electors/ARs are serving their sentences insofar as practicable. [S 31(1), (3A) and (6) of the EAC (EP) (LC) Reg] *[Amended in January 2010 and June 2016]*

5.11 In the case where the number of validly nominated candidates for a constituency does not exceed the number of vacancies, the candidate(s) will be declared elected [s 46(1) of the LCO and s 22(1) and (2) of the EAC (EP) (LC) Reg]. Electors in respect of such a constituency do not need to vote, and a notice to that effect will be sent to them.

5.12 An elector/AR **may vote only at the polling station allocated to him/her** by the CEO [s 32 of the EAC (EP) (LC) Reg]. Most of the polling stations are accessible to persons with mobility difficulty. Whether the polling station allocated to an elector/AR is accessible to persons who are wheelchair users or have difficulty in walking will be specified clearly in the location map attached to the poll card sent to each elector/AR. If an elector/AR with mobility difficulty is allocated to a polling station not accessible to him/her, he/she may **at least 5 days** before the polling day apply to the CEO for re-allocation to a special polling station [s 33(2) of the EAC (EP) (LC) Reg]. If a special polling station is re-allocated to an elector/AR, then he/she can vote only at that polling station. Subject to availability, free Rehabus service may also be arranged to take those electors/ARs to the special polling station. In case special circumstances require, the CEO may allocate to an elector/AR an alternative polling station, in addition to or in substitution of the one originally allocated to him/her [s 30(4A) of the EAC (EP) (LC) Reg]. Electors/ARs concerned can make enquiries with the REO on this subject by

telephone or in writing. *[Amended in October 2007 and June 2016]*

5.13 Due to security reasons, there is a need to separate some persons imprisoned or held in custody from others inside the penal institutions. The Commissioner of Correctional Services shall assign a time slot during the polling hours of a dedicated polling station situated in a penal institution to an elector allocated to that polling station to vote, and inform the elector of the time slot assigned. The Commissioner of Correctional Services must assign time slots so as to give the electors a reasonable opportunity to vote. An elector to whom a time slot is assigned may only cast his/her vote during that time slot (see para. 5.29 below). [S 27(2A), (2B), (3A) and (4A) of the EAC (EP) (LC) Reg] *[Amended in January 2010]*

PART II : OUTSIDE THE POLLING STATION

5.14 Unless it is not practicable to do so, the PRO will arrange a copy of the relevant Introduction to Candidates published by the REO to be displayed outside the polling station, or if it is a dedicated polling station inside the polling station, to facilitate easy reference by electors. *[Amended in June 2012]*

5.15 The CEO will display a map or plan showing the respective boundaries of the polling station outside the polling station, or if it is a dedicated polling station inside the polling station [s 43(1A) of the EAC (EP) (LC) Reg]. A NCZ will be designated outside each polling station to ensure the free and safe passage of electors into the polling station. A NSZ in which no one is allowed to stay or loiter will also be designated immediately outside the entrance/exit of a polling station to avoid any obstruction of entry/exit. The RO or the PRO of the relevant polling station will not allow canvassing activities within a NCZ (except for static display of EAs mounted at designated

spots approved by the RO). A notice of the declaration of a NCZ and a map or plan showing the boundary of the area will be put up at or near the polling station [s 40(10) of EAC (EP) (LC) Reg]. Door-to-door canvassing and, for the purpose of such canvassing, the display or wearing of any propaganda material, e.g. any badge, emblem, clothing or head-dress, which may promote or prejudice the election of a candidate or candidates at the election, or makes direct reference to a body any member of which is standing as a candidate in the election or to a prescribed body the registered name or registered emblem of which has been printed on any ballot paper for the election [see paras. 4.38 to 4.42 above], will be allowed on the storeys above or below street level in a building within a NCZ other than a building in which there is a polling station, provided that permission has been obtained for entry to the building for canvassing votes, and that obstruction is not posed to electors and no sound amplifying device is used [s 40 of EAC (EP) (LC) Reg]. [See Chapter 14] *[Amended in October 2007, July 2008, January 2010, June 2012 and June 2016]*

5.16 On the polling day, a person must not:

- (a) engage in canvassing votes (including suggesting not to vote for any candidate) within the NCZ other than the door-to-door canvassing activities stated in para. 5.15 above; *[Amended in October 2007]*
- (b) use a sound amplifying system or device for any purpose within the NCZ, except for the performance of duties by officers of the CSD on the polling day at the dedicated polling stations situated in prisons; *[Amended in June 2012]*
- (c) use a sound amplifying system or device, or conduct any activity (e.g. lion dance) for canvassing votes, so that the sound emitted

by it can be heard in the NCZ;

- (d) display or wear in the NCZ any propaganda material, e.g. any badge, emblem, clothing or head-dress (except for static display of EAs mounted at designated spots approved by the RO), which:
 - (i) may promote or prejudice the election of a candidate or candidates at the election; or
 - (ii) makes direct reference to a body any member of which is standing as a candidate in the election or to a prescribed body the registered name or registered emblem of which has been printed on any ballot paper for the election; or
- (e) stay or loiter in the NSZ without the express permission of the PRO;

otherwise he/she commits an offence with a maximum penalty of a fine at level 2 (\$5,000) and to imprisonment for 3 months [ss 40(16), (17), (19) and 45(5) and (7) of the EAC (EP) (LC) Reg]. *[Amended in October 2007, June 2012 and June 2016]*

PART III : COMMENCEMENT OF POLLING

5.17 The poll starts at 7:30 am and ends at 10:30 pm. For security reasons, dedicated polling stations situated in prisons open from 9:00 am to 4:00 pm. About 15 minutes before the commencement of polling, the PRO at a polling station will show the candidates, their election agents or polling agents, if they are present, the empty ballot boxes before proceeding to lock and seal them. Candidates concerned or their agents may observe the locking

and the sealing of the ballot boxes. For each candidate/list of candidates, only 1 such person may be present to observe the locking and the sealing of the ballot boxes: a candidate, the election agent or a polling agent. For dedicated polling station, due to security reasons,

- (a) only a maximum of 2 candidates may be present to observe the locking and the sealing of the ballot boxes at a dedicated polling station situated inside a maximum security prison; and
- (b) a maximum of 2 candidates, election agents or polling agents may be present to observe the locking and the sealing of the ballot boxes at a dedicated polling station situated in a prison other than a maximum security prison.

Admission of candidates, election agents or polling agents to the aforesaid dedicated polling stations to observe the locking and sealing of ballot boxes will be on a **first-come-first-served basis**. Where no candidates or any of their agents are present at the polling station, the above process of locking and sealing of ballot boxes will be conducted in the presence of any two of the following persons: police officer, member of the Civil Aid Service (“CAS”), officer of the CSD or polling staff, as the case may be, present at the polling station. [See also Chapter 7 on the procedures for applying for the presence of election agents or polling agents in dedicated polling stations situated in prisons.] *[Amended in January 2010 and June 2016]*

5.18 For a small polling station where the votes cast will not be counted therein, a notice about the venue for the counting of votes will be displayed by the PRO outside the station [s 39(1A) of the EAC (EP) (LC) Reg]. For a dedicated polling station, a notice providing information on the ballot paper sorting station (if any) and the main counting station will be displayed inside the station [s 39(1B) of the EAC (EP) (LC) Reg]. Before polling starts,

the PRO will also inform and show to the candidates, their election agents or polling agents, if they are present, the number of unissued ballot papers relating to the constituency, which are in his/her possession. *[Amended in January 2010]*

5.19 In the polling stations, there will be different sets of ballot papers for GC and the different FCs and corresponding ballot boxes. For ballot papers, there will be 30 different sets, 1 for the particular GC for which the polling station is designated and 1 for each of the 29 FCs in an ordinary polling station, whereas there will be 34 different sets, 1 for each of the 5 GCs and the 29 FCs, in a dedicated polling station. There will be 3 different sets of ballot boxes, 1 to hold the ballot papers cast for the GCs, 1 to hold the ballot papers cast for the DC (second) FC and 1 to hold the ballot papers cast for the ordinary FCs/SFCs (combined). *[Amended in June 2012]*

5.20 The GC and FC ballot papers are easily distinguishable by different colour patterns, sizes or code, at the back and/or in the front, to facilitate easy identification in the polling and counting process.

PART IV : ADMISSION TO THE POLLING STATION

5.21 Other than electors, the following persons may also be admitted to a polling station:

- (a) the PRO and other polling staff;
- (b) the Chief Returning Officer (“CRO”);
- (c) ROs and Assistant Returning Officers (“AROs”) for the relevant constituency;

- (d) members of the EAC;
- (e) the CEO;
- (f) police officers and members of the CAS on duty at the polling station;
- (g) officers of CSD and other law enforcement agencies on duty at dedicated polling stations;
- (h) candidates and election agents of the relevant constituency subject to para. 5.22;
- (i) polling agent(s) appointed for the polling station (this does not apply to dedicated polling stations situated in maximum security prisons) subject to para. 5.22;
- (j) public officers authorised in writing by the CEO;
- (k) any person authorised in writing by a member of the EAC;
- (l) a person authorised in writing by the RO for liaison purposes; and
- (m) a child who accompanies an elector who enters the polling station for the purpose of voting (if the PRO considers that the child should not be left unattended while that elector is in the polling station and the child will not disturb or cause inconvenience to any person in the polling station). *[Amended in October 2007]*

[S 44(4), (5) and (13) of the EAC (EP) (LC) Reg] *[Amended in October 2007 and January 2010]*

A notice will be displayed at the entrance to polling stations (other than dedicated polling stations) to show that only the above persons and electors may be allowed to enter.

5.22 For the purpose of maintaining order in the polling station, the PRO may regulate the number of electors/ARs, candidates, election agents and polling agents to be admitted to the polling station at any one time: [S 44(2) of the EAC (EP) (LC) Reg]

- (a) For each candidate/list of candidates, only 1 of the following persons may be present in the polling station to observe the poll at any one time: a candidate, the election agent or a polling agent.
- (b) A notice will be displayed outside each polling station showing the capacity of the designated area inside the polling station for candidates, their election agents or polling agents to observe the poll. [S 44(7) and (8) of the EAC (EP) (LC) Reg]
- (c) Admission of candidates, election agents and polling agents will be on a **first-come-first-served basis**. In order that as many candidates, election agents and polling agents as possible may have the chance to observe the poll at the polling station, any candidate, election agent or polling agent who has been admitted to the polling station may only stay for 1 hour. He/She must then leave the polling station unless there is no other candidate, election agent or polling agent waiting for admission. He/She may apply for re-admission into the polling station again on a first-come-first served basis. *[Amended in June 2016]*
- (d) Anyone on admission into a polling station has to sign and enter his/her time of entry on a log sheet. A candidate, election agent

or polling agent who has to queue outside the polling station for his/her turn to observe the poll at the designated area will be given a number chit that indicates the order of admission. The polling staff will call out the number to admit the holder of the number chit concerned. If the holder concerned is not present at the time, his/her place will be taken over by the person next in line. He/She who has lost his/her place due to his/her absence will have to obtain a new number chit when he/she returns.

- (e) As stated in (c) above, to ensure fairness, waiting slots for entering a polling station are all allocated on a first-come-first-served basis. If a candidate or his/her agent seeks admission to a polling station but all the waiting slots are full until the close of poll, no vacant slot can be allocated to the candidate or his/her agent. However, if none of this candidate or his/her agent has earlier entered the polling station to observe the poll on the polling day, the PRO concerned will endeavour to give the candidate/agent an opportunity to enter the polling station to observe the poll before the close of poll under a special arrangement. Under this special arrangement, the person will replace the candidate or his/her agent who has been allocated the last waiting slot for admission to the polling station if this last candidate or any of his/her agents has already been given an earlier slot to observe the poll at that polling station.

The above special arrangement will apply to a list of candidates in a similar way and the reference to a candidate should be construed to mean any candidate on the list.

[Added in June 2016]

- (f) For security reasons, only a maximum of 2 candidates may be present at any one time to observe the poll at a dedicated polling station situated inside a maximum security prison, and a maximum of 2 candidates, election agents or polling agents may be admitted to a dedicated polling station situated in a prison other than a maximum security prison at any one time. Observers will have to take turn in case more than two candidates/agents intend to observe the poll at the same time. The PRO may regulate the number of people entering the dedicated polling stations. [See also Chapter 7]

[Amended in January 2010 and June 2016]

5.23 Except for an elector, a police officer, an officer of the CSD, an officer of any law enforcement agency or a member of the CAS on duty, all other persons permitted to enter a polling station are required to sign a **Declaration of Secrecy** on a specified attested form and observe the provisions governing the secrecy of voting [s 95 of the EAC (EP) (LC) Reg]. *[Amended in January 2010]*

PART V : CONDUCT INSIDE THE POLLING STATION

5.24 Polling stations are designated for the GCs as well as FCs for the convenience of electors. Inside each polling station, a notice will be displayed to inform electors that polling for the relevant GC and all the FCs is being held concurrently, and that an elector will be issued with 1, 2 or 3 **different ballot papers**, depending on his/her entitlement. **The ballot papers** issued to the elector so entitled **will be issued at the same time**. Such elector who wishes to exercise the right to cast any of his/her votes will have to do so at the **same visit** to the polling station. *[Amended in June 2012]*

5.25 On arrival at the polling station, an elector/AR should show to the polling staff at the ballot paper issuing desk his/her identity card or such other identity document or documents, which show the identity card/document number, name and photograph of the elector, to the satisfaction of the polling staff or PRO [s 50 of the EAC (EP) (LC) Reg]. The polling staff will check the elector/AR's identity document against the entries on the copy of register of electors to ascertain if the elector/AR is registered in respect of both the GC, and one or two of the 29 FCs. The polling staff will call out the name of the elector/AR as stated in the entry in the copy of the register of electors and cross out the name and the identity document number of that entry, before giving him/her either 1, 2 or 3 ballot papers, depending on his/her entitlement. If an elector/AR is entitled to be issued with 2 or more ballot papers, all the ballot papers must be handed over to him/her at the same time. An elector/AR may be asked to check the number of ballot papers issued to him/her to ensure that he/she has been given the correct ballot paper(s). No record will be made as to which particular ballot paper is given to an elector/AR. [S 53 of the EAC (EP) (LC) Reg] *[Amended in June 2012 and June 2016]*

5.26 For control purpose regarding the total number of ballot papers issued, the counterfoil of each ballot paper bears a serial number on its front. However, the serial number on the counterfoil will not be recorded as correlating to the particular elector to whom the ballot paper is issued.

5.27 If there is reasonable grounds for questioning the bona fides of an elector, the PRO shall ask him/her the following questions at the time of his/her application for a ballot paper (but not afterwards):

- (a) Are you the person registered in the final register now in effect for this GC and/or FC (as appropriate), as follows (reads the whole of the relevant entry in the register)? *[Amended in October 2007]*

- (b) Have you already voted for this or any other GC and/or FC (as appropriate) in this election?

The person will not be issued with any ballot paper unless he/she has answered the questions to the satisfaction of the PRO [s 51(3) and (5) of the EAC (EP) (LC) Reg]. *[Amended in October 2007]*

5.28 Where there is reasonable cause to believe that a person has committed an offence of impersonation of an elector, the PRO may request the police officer on duty at the polling station to arrest that person. If the polling station is a dedicated polling station, the PRO may request the officer of the CSD or the law enforcement agency to remove the person concerned from the polling station and report the case to the police [s 52(1), (2) and (2A) of the EAC (EP) (LC) Reg]. *[Amended in January 2010]*

5.29 If an elector has been issued with one or more ballot papers but leaves the station without casting any or all of the votes, he/she cannot return to the polling station later to cast the vote(s) not yet cast, except under the following circumstances:

- (a) if, after having been issued with one or more ballot papers, an elector has become incapacitated from voting or completing the voting by physical illness and has left the polling station without marking his/her ballot paper or any or all of the ballot papers, he/she may return to the polling station to cast his/her vote(s) before the close of poll, provided that before he/she leaves the polling station, his/her ballot paper(s) has been retrieved by the PRO; or
- (b) for a reason considered justified by the PRO, an elector who has

not marked the ballot paper(s) issued to him/her may, with the permission of the PRO, hand back the ballot paper(s) to the PRO and return later to cast his/her vote(s); and

- (c) for a dedicated polling station situated in a prison, the elector has to return to cast his/her vote(s) within the existing or any newly assigned time slot.

Under the above circumstances, the following actions must be taken by the PRO and/or the Commissioner of Correctional Services or his officer:

- (a) the PRO must keep the ballot paper(s) in his/her custody and re-issue such ballot paper(s), in the presence of a police officer for polling stations other than a dedicated polling station or an officer of the CSD or any law enforcement agency for a dedicated polling station, to the elector in question when the latter returns before the close of poll to cast his/her vote(s); and/or
- (b) the Commissioner of Correctional Services or his officer must, as far as practicable, assign to an elector of a dedicated polling station situated in a prison a new time slot during the polling hours appointed for the polling station and notify the elector of the time slot [s 53A(2A) and (5A) of the EAC (EP) (LC) Reg]; and
- (c) if at the close of poll, the elector has not returned, the PRO shall endorse the ballot paper(s) with the word “**UNUSED**”; such ballot paper(s) shall not be counted [ss 53A, 61 and 80 of the EAC (EP) (LC) Reg].

[Amended in January 2010 and June 2016]

5.30 The PRO would only need to keep a ballot paper left in the polling station in his/her custody in the circumstances described in para. 5.29 above when he/she knows which elector had left the ballot paper behind. Otherwise, a ballot paper found to be left in the polling station should be endorsed as “UNUSED” and would not be counted. *[Amended in June 2016]*

5.31 When issued with the ballot paper(s), an elector/AR will also be provided with a cardboard to which a chop with a tick “✓” is attached (as well as a pen for marking the SFC ballot papers as applicable). Persons who are supplied with 1 GC ballot paper only will be required to carry **green** cardboard to show that they have only 1 ballot paper. Persons who are supplied with 1 GC ballot paper and 1 DC (second) FC ballot paper will be required to carry a **white** cardboard, whereas those who are supplied with 1 GC ballot paper and 1 FC other than DC (second) FC ballot paper will be required to carry a **red** cardboard. Persons who are issued with 1 GC ballot paper and 2 FC ballot papers will be required to carry a **blue** cardboard. This arrangement is to facilitate the control and monitoring of the casting of the ballot papers into the correct ballot boxes and also to prevent any person from taking away any ballot paper from the polling station. The cardboard will be collected by the polling staff after the elector/AR has inserted his/her ballot paper(s) into the ballot box(es) before leaving the polling station. *[Amended in June 2012 and June 2016]*

5.32 After being issued with the ballot paper(s) and the cardboard to which a chop with a tick “✓” is attached (as well as a pen for marking the SFC ballot papers as applicable), the elector/AR should immediately proceed to one of the voting compartments where he/she would mark his/her ballot paper(s) to indicate his/her choice of the candidate(s)/list of candidate(s). The manner in which a ballot paper should be marked for the GC, the DC (second) FC, the other 24 ordinary FCs and the 4 SFCs are different, depending on the

applicable voting system. An elector/AR should read carefully the instructions given on the ballot paper and follow the instructions in marking his/her choice of candidate(s)/list of candidate(s). One compartment may be used only by one elector at one time. *[Amended in June 2012 and June 2016]*

5.33 Briefly speaking, the ballot paper(s) should be marked in the following way –

- (a) In respect of a ballot paper for the GC and the DC (second) FC election to which the list system of proportional representation is applicable, the elector has only one vote and he/she must affix the chop supplied to mark a single “✓” against the list containing one or more candidates’ names of his/her choice in the circle provided (as opposed to each individual candidate’s name).
- (b) In respect of a ballot paper for the 24 ordinary FCs to which the first past the post voting system is applicable, the elector/AR is entitled to cast 1 vote and must indicate his/her choice of candidate of the relevant FC by marking a single “✓” against the candidate of his/her choice in the circle provided, save in the Labour FC which has 3 vacancies to fill, then the elector may mark a “✓” against the names of up to 3 candidates.
- (c) The ballot paper for the 4 SFCs to which the preferential elimination voting system is applicable will have all the candidates’ names printed on it with corresponding circles against each name for the elector/AR to mark his/her preferential choices. He/She must use the pen provided to indicate his/her preference, by writing **Arabic numerals** (1, 2, 3, etc.) in the circle opposite the names of the candidates, in descending order of preference, i.e.: *[Amended in June 2012]*

- (i) writing “1” in the circle opposite the name of the candidate of his/her first preference (“first preference vote”);
- (ii) writing “2” in the circle opposite the name of the candidate of his/her second preference;

and so on. **An elector/AR must mark a first preference vote** for validity of the vote, he/she may, if he/she wishes, mark the second, third and subsequent preferences for as many candidates as are indicated on his/her ballot paper. [Ss 55, 56 and 57 of the EAC (EP) (LC) Reg] *[Amended in June 2012 and June 2016]*

5.34 For an elector of the GC or the DC (second) FC, after he/she has marked the ballot paper(s) to indicate his/her choice of the list of candidates, he/she should **fold the ballot paper(s) so that the marked side is inside**. For an elector/AR of the ordinary FCs/SFCs, he/she must **not fold his/her ballot paper** before inserting it face down into the ballot box. [S 54(3) and (3A) of the EAC (EP) (LC) Reg] *[Amended in June 2012]*

5.35 Immediately after an elector/AR comes out of the voting compartment, he/she should put his/her marked ballot paper(s), folded or unfolded as the case may be, into the ballot box(es) as directed by the polling staff. An elector should insert the GC ballot paper into the ballot box designated for the GC ballot papers. If he/she is an elector of the DC (second) FC, he/she should insert the ballot paper into the ballot box designated for the DC (second) FC. For an elector/AR of the ordinary FCs/SFCs, he/she should insert the ordinary FC/SFC ballot paper(s) facing down into the ballot boxes designated for the ordinary FCs/SFCs. The elector/AR should then return the cardboard with the chop (and the pen for marking the SFC ballot papers as the case may be) to the polling staff and leave the polling station immediately.

[S 54 of the EAC (EP) (LC) Reg] [*Amended in July 2008, June 2012 and June 2016*]

NOTE :

An elector/AR must not remove a ballot paper from a polling station. It is an offence under s 54(6) of the EAC (EP) (LC) Reg for a person to bring out a ballot paper from a polling station. Further, any person who removes a ballot paper from a polling station with intent to deceive may commit an offence under s 17(1)(c) of the ECICO and may be prosecuted. It will also be a corrupt conduct under s 17(1)(d) of the ECICO if any person, without lawful authority, destroys, defaces, takes or otherwise interferes with a ballot paper at the election.

5.36 An elector with visual impairment who so requests will be provided with a **braille template** to facilitate his/her marking of the ballot paper by himself/herself. The template should be returned to the polling staff after use. [S 59(3) of the EAC (EP) (LC) Reg] [For details about the template, see para. 7.41 of Chapter 7.] [*Amended in June 2016*]

5.37 An elector/AR who is unable to mark a ballot paper by himself/herself to indicate the choice of candidate (e.g. being unable to read or incapacitated by visual deficiency or other physical cause) may ask the PRO, Deputy PRO or Assistant PRO to mark the ballot paper on his/her behalf. The marking of the ballot paper will be made to show the elector's choice in the presence of one of the polling officers as a witness [s 59(1) and (2) of the EAC (EP) (LC) Reg].

5.38 **The ballot is secret. No one can force a person to vote or not to vote for any particular candidate** [s 13 of the ECICO]. **Also no one is**

required to tell which candidate he/she has voted for or is going to vote for.

A person who, without lawful authority, requires or purports to require an elector to disclose the name of, or any particular relating to, the candidate for whom the elector has voted commits an offence [s 60 of the LCO]. S 96 of the EAC (EP) (LC) Reg prohibits necessary acts which may infringe the secrecy of the vote during the polling and counting process. If a person contravenes any of the acts prohibited under this section, he/she commits an offence and will be liable to a fine at level 2 (\$5,000) and to imprisonment for 6 months.

5.39 For the protection of the elector/AR's privacy, no one shall, at any time, disclose whether an elector/AR has or has not applied for a ballot paper or voted; or disclose the identity of an elector/AR at a dedicated polling station. Anyone who makes such disclosure commits an offence and will be liable to a fine at level 2 (\$5,000) and to imprisonment for 6 months. [S 96(1A) and (10) of the EAC (EP) (LC) Reg] *[Added in January 2010 and amended in June 2016]*

5.40 Any elector/AR who has inadvertently torn or damaged any ballot paper or has made an error in marking any ballot paper issued to him/her may ask the PRO to exchange it for another unmarked ballot paper. If the PRO considers the request reasonable, he/she will issue a new ballot paper to the elector/AR in exchange for the spoilt ballot paper. Such spoilt ballot papers will be endorsed on the front with the word "**SPOILT**" and will be kept by the PRO. The spoilt ballot papers will not be counted at the counting of the votes. [Ss 62 and 80 of the EAC (EP) (LC) Reg] *[Amended in June 2016]*

5.41 Where a person, claiming to be a particular elector/AR entered on the register, applies for a ballot paper after a person has already been issued with a ballot paper as such an elector/AR, the PRO may issue a tendered ballot paper to the latter elector/AR **only if** he/she is not certain that the latter person

is the former person who had been issued with a ballot paper earlier, and the latter person has answered the appropriate questions in accordance with the law as set out in para. 5.27 to the satisfaction of the PRO. The PRO may in such circumstances issue a ballot paper with the word “**TENDERED**” endorsed on the front. Such a ballot paper shall not be counted at the counting of the votes. [Ss 60(1) and 80(1)(b) of the EAC (EP) (LC) Reg] *[Amended in July 2008]*

5.42 Ballot papers which have been issued (whether marked or unmarked) may sometimes be abandoned or found left behind by electors/ARs in the voting compartments or lying on the floor of the polling station, or otherwise not used. Any person who discovers such a ballot paper is required to hand it to the PRO. Such a ballot paper will be endorsed on the front with the word “**UNUSED**” and will be kept by the PRO. In no circumstances shall such ballot paper be put into a ballot box. Such a ballot paper will not be counted at the counting of the votes. [Ss 61 and 80 of the EAC (EP) (LC) Reg] *[Amended in June 2016]*

5.43 Subject to para. 5.44, no person including an elector/AR should interfere with or attempt to influence any other elector/AR, especially no one shall:

- (a) speak to or communicate with any other elector/AR contrary to a direction of the RO, ARO, PRO or any polling officer not to do so;
- (b) attempt to obtain information, or disclose any knowledge acquired, concerning the vote of another elector/AR;
- (c) exhibit or distribute any campaign material;
- (d) display or wear any propaganda material, e.g. any badge, emblem,

clothing or head-dress, which:

- (i) may promote or prejudice the election of a candidate or candidates at the election; or
 - (ii) makes direct reference to a body any member of which is standing as a candidate in the election or to a prescribed body the registered name or registered emblem of which has been printed on any ballot paper for the election; or
- (e) use a mobile telephone or any telephone or paging machine or any other form of electronic communication device contrary to a direction of the RO, ARO, PRO or any polling officer not to do so.

If a person contravenes any of the above prohibitions, he/she commits an offence and will be liable to a fine at level 2 (\$5,000) and to imprisonment for 3 or 6 months, as the case may be. [Ss 45 and 96 of the EAC (EP) (LC) Reg] *[Amended in October 2007 and July 2008]*

5.44 Only the following persons may speak to or communicate with electors/ARs, and use a mobile telephone, paging machine or any other form of electronic communication device within a polling station:

- (a) the PRO and other polling staff;
- (b) the ROs and AROs for the relevant constituency;
- (c) members of the EAC;
- (d) the CEO;

- (e) police officers and members of the CAS on duty at the polling station;
- (f) an officer of the CSD or other law enforcement agency on duty at a dedicated polling station;
- (g) a person authorised in writing by the ROs for liaison purposes; and
- (h) any person authorised in writing by a member of the EAC.

[S 45(1) and (6) of the EAC (EP) (LC) Reg] *[Amended in January 2010 and June 2016]*

5.45 A person who misconducts himself/herself at a polling station or its vicinity or fails to obey any lawful order of the RO or the PRO commits an offence and will be liable to a fine and to imprisonment and may be ordered by such officer to leave the polling station or the vicinity of the polling station. A person misconducts himself/herself if he/she disrupts the poll or disturbs or causes inconvenience to any person in the polling station. An elector/AR must cast his/her vote without undue delay. If an elector/AR who is allocated to vote at a dedicated polling station fails to cast his/her vote without undue delay, the RO or the PRO may order him/her to leave the polling station immediately. If a person fails to leave immediately as ordered by the RO or the PRO, he/she may be removed by:

- (a) a police officer if the polling station is not a dedicated polling station; or
- (b) an officer of the CSD or other law enforcement agency if the

polling station is a dedicated polling station; or

- (c) any other person authorised in writing by the RO or the PRO to remove him/her.

The person so removed may not re-enter the polling station on that day except with the permission of the RO or the PRO. [S 46(2), (2A), (3) and (4) of the EAC (EP) (LC) Reg] *[Amended in January 2010]*

5.46 Any person who undertakes photographing, filming and video or audio recording within a polling station without the express permission of the PRO, the RO for the constituency or constituencies for which the polling station is used or a member of the EAC, commits an offence and will be liable to a fine at level 2 (\$5,000) and to imprisonment for 6 months [s 45(2) and (7)(a) of the EAC (EP) (LC) Reg]. Normally such permission is only granted to members of the media or government photographers for publicity purposes. *[Amended in October 2007 and July 2008]*

PART VI : CLOSE OF POLL

5.47 Electors who intend to vote but are not already at the door of their designated polling station by the close of poll will not be allowed in afterwards. *[Amended in January 2010]*

A Polling Station which is also a Counting Station

5.48 Except for small polling stations and dedicated polling stations, all other polling stations will be designated as counting stations for the counting of GC votes. At the close of poll, a notice will be displayed by the PRO outside these polling stations to inform the public that the poll has been

closed and that the station is being arranged for the counting of votes and will be open to them when such arrangements are completed. A candidate, and his/her election agent, a counting agent and a polling agent may stay inside the polling station while it is closed for the preparation for the counting of votes. The ballot boxes will be locked and sealed by the PRO in the presence of the candidates and their agents, if they are present. The PRO will also inform them of the numbers of unissued ballot papers, spoilt ballot papers and unused ballot papers in his/her possession. All such ballot papers and the marked copies of the registers will then be made up into separate sealed packets for the respective constituencies. [S 63(1), (1A), (2) and (3) of the EAC (EP) (LC) Reg] *[Amended in January 2010 and June 2016]*

5.49 The sealed ballot boxes and sealed packets referred to in para. 5.48 above will be kept by the PRO until the counting of the GC votes begins, when all GC ballot boxes will be opened and all ballot papers inside will be put on the counting table (GC sealed packets will be kept in PRO's safe custody until delivery to the RO). For the counting of FC votes, the sealed ballot boxes and the sealed packets referred to in para. 5.48, together with any FC ballot papers found to have been misplaced in GC ballot boxes [see para. 5.69 below], will be delivered to the central counting station. Up to 2 persons being candidates competing in the FCs (or their respective agents), if they so wish, will be allowed to accompany the Deputy PRO/Assistant PRO in the delivery of the ballot boxes from the polling station to the central counting station under police escort. Where there are more than 2 such persons wishing to accompany in the delivery, the PRO will draw lots to determine which 2 persons will be allowed. FC candidates and their agents are allowed to remain in the polling station until they see that the police escort for the delivery is available. Thereafter, all of them shall leave the polling station. They may enter the counting station to observe the count of the GC votes in the public area. *[Amended in June 2012 and June 2016]*

A Polling Station which is not a Counting Station

5.50 Small polling stations and dedicated polling stations will not be converted into a counting station after the close of poll. For small polling station, a notice will be displayed by the PRO outside the polling station to inform the public that the poll has been closed. After the close of poll, a candidate, his/her election and polling agent may stay in the polling station to observe the process of locking and sealing of ballot boxes. For dedicated polling station, the following persons may stay behind to observe the process:

- (a) a candidate, his/her election agent and a polling agent may stay in a dedicated polling station not situated in a prison;
- (b) a maximum of 2 candidates, election agents or polling agents may stay in a dedicated polling station situated in a prison other than a maximum security prison; and
- (c) a maximum of 2 candidates may stay in a dedicated polling station situated in a maximum security prison.

[S 63A(2) and (2A) of the EAC (EP) (LC) Reg] *[Amended in January 2010 and June 2016]*

In the presence of the candidates and/or their agents, if any, the ballot boxes will be locked and sealed by the PRO. The PRO will also inform them of the numbers of unissued ballot papers, spoilt ballot papers and unused ballot papers in his/her possession. All such ballot papers and the marked copies of the register will then be made up into separate sealed packets. [S 63A(1) of the EAC (EP) (LC) Reg] *[Added in June 2016]*

5.51 For the small polling stations which have not been designated as

counting stations for GC votes, the sealed ballot boxes, the sealed packets of unissued ballot papers, etc. and ballot paper accounts, etc. for the GCs and FCs will be first delivered to the main counting station by the PRO/Deputy PRO under police escort. The PRO of a dedicated polling station will deliver the sealed GCs and FCs ballot boxes, the sealed packets of unissued ballot papers, etc. and the ballot paper accounts etc. under police escort to:

- (a) the PRO of the ballot paper sorting station concerned in the case of a LegCo general election or by-election in which such a ballot paper sorting station has been set up;
- (b) the PRO of the main counting station concerned in the case of a LegCo by-election in respect of a GC in which no ballot paper sorting station has been set up; or
- (c) the RO of the counting station concerned in the case of a LegCo by-election in respect of a FC.

[S 63A(3) and (4) of the EAC (EP) (LC) Reg] *[Amended in January 2010]*

The FC ballot boxes at the main counting stations and the ballot paper sorting stations, together with any misplaced FC ballot papers found inside the GC ballot boxes, will then be delivered to the central counting station for counting [see paras. 5.69 and 5.78 below for details]. *[Amended in June 2012]*

5.52 Not more than 2 candidates and/or their agents, if they so wish, will be allowed to accompany in the delivery. Where there are more than 2 of them wishing to accompany in the delivery, the PRO will draw lots to determine which 2 persons will be allowed. Candidates and their agents are allowed to remain in the polling station only until they see that the police escort for the delivery is available, and thereafter all of them, except those 2 persons

who are to accompany in the delivery, must leave the polling station.

[Amended in January 2010 and June 2016]

PART VII : SORTING OF BALLOT PAPERS

Conduct at the Ballot Paper Sorting Station

5.53 In a LegCo general election or, where the CEO considers it appropriate in a LegCo by-election, ballot paper sorting station(s) will be set up for sorting GC ballot papers received from dedicated polling stations according to each GC before the GC ballot papers are delivered to the respective main counting stations for the counting of votes. The PRO of a ballot paper sorting station may determine the time at which the sorting of ballot papers is to begin, which must be a time after the poll has closed at all the dedicated polling stations situated in prisons and may be a time before the poll has closed at all the other polling station(s). Before the polling day, candidates will be informed of the expected time of the commencement of the sorting of ballot papers at the ballot paper sorting station(s). [Ss 2(6), 28(1)(c), 63A(4) and 65(2A) of the EAC (EP) (LC) Reg] *[Added in January 2010]*

5.54 The following persons may be present at the sorting of ballot papers:

- (a) the ROs, AROs, PROs, Deputy PROs, Assistant PROs and counting staff for the relevant constituencies;
- (b) the CRO; *[Added in June 2012]*
- (c) members of the EAC;

- (d) the CEO;
- (e) candidates and their election agents and counting agents of the relevant constituencies;
- (f) police officers and members of the CAS on duty at the ballot paper sorting station;
- (g) public officers authorised in writing by the CEO;
- (h) any person authorised by the CRO, the RO or the PRO; and
[Amended in June 2012]
- (i) any person authorised in writing by a member of the EAC.

The PRO will designate a restricted area where the counting staff will sort the ballot papers. Candidates and their agents must not go into the restricted area. Any member of the public may observe the sorting of ballot papers from the public area designated by the PRO unless the PRO considers that his/her presence may:

- (a) cause disorder or disturbance in the ballot paper sorting station;
or
- (b) prejudice the secrecy of individual votes.

[Ss 2(6) and 68(1) and (2) of the EAC (EP) (LC) Reg] *[Added in January 2010 and amended in June 2012]*

5.55 Before entry, every person authorised to be present at a ballot paper sorting station, other than the police officers and members of the CAS on

duty, must make a **Declaration of Secrecy** on a specified form and observe the provisions governing the secrecy of voting [ss 2(6) and 95 of the EAC (EP) (LC) Reg]. Members of the public present within the public area will not be required to make a Declaration of Secrecy. *[Added in January 2010]*

5.56 Except with the express permission of the relevant PRO, the CRO, or the RO for the constituency or constituencies for which the ballot paper sorting station is used or a member of the EAC as the case may be, any person who undertakes photographing, filming and video or audio recording within the restricted area of a ballot paper sorting station during the period commencing from the time at which the sorting of GC ballot papers is to begin and ending upon the completion of the sorting commits an offence [ss 2(6), 68A(1) and (2) of the EAC (EP) (LC) Reg]. *[Added in January 2010 and amended in June 2012]*

5.57 A person who misconducts himself/herself in or in the vicinity of a ballot paper sorting station or fails to obey any lawful order of the PRO commits an offence and will be liable to a fine and to imprisonment and may be ordered by the PRO to leave the area. A person misconducts himself/herself if he/she disrupts the sorting of GC ballot paper or disturbs or causes inconvenience to any person in the sorting station. The PRO may also order a person to leave the ballot paper sorting station if the person behaves himself/herself in such way that the purpose of his/her presence is not that for which he/she was authorised or permitted to enter or remain in the ballot paper sorting station. If he/she fails to leave immediately, he/she may be removed by a police officer or by any other person authorised in writing by the PRO to remove him/her. The person so removed may not re-enter the ballot paper sorting station on that day except with the permission of the PRO [ss 2(6), 68A(3) and 69(2A), (3) and (4) of the EAC (EP) (LC) Reg]. *[Added in January 2010]*

Sorting of Ballot Papers

5.58 The PRO of a ballot paper sorting station will sort the GC ballot papers, delivered from dedicated polling station(s), in the presence of the candidates, their election or counting agents, if they are present. The PRO will check whether GC ballot boxes and sealed packets are properly sealed. The seal on the ballot box will be broken by the PRO in the presence of the candidates, their election or counting agents, if they are present at the time. The ballot box will then be opened and the contents emptied onto a sorting table. After the PRO has opened the ballot box, the candidates, their election or counting agents may request to inspect any papers, other than the marked ballot papers, taken out from the ballot boxes before they are disposed of. **At no time should a candidate, his/her election agent or counting agent touch any ballot papers.** *[Added in January 2010]*

5.59 The PRO of a ballot paper sorting station shall:

- (a) open the GC ballot boxes received from dedicated polling stations;
- (b) sort the GC ballot papers in each ballot box according to each GC;
- (c) count and record the number of GC ballot papers for each GC in each GC ballot box;
- (d) verify the ballot paper account by comparing it with the number of GC ballot papers recorded under para. 5.59(c) above;
- (e) prepare a statement in writing as to the result of the verification;

- (f) prepare a statement in writing as to the number of GC ballot papers recorded under para. 5.59(c) above;
- (g) make into separate bundles the sorted GC ballot papers together with the relevant statement prepared under para. 5.59(f) above;
- (h) place each bundle in a separate receptacle and seal it in the presence of those present at the counting zone;
- (i) arrange the receptacles to be delivered to the PROs of the respective main counting stations of the relevant GCs ¹¹; *[Amended in June 2016]*
- (j) send to the CEO the ballot paper accounts, verification of the ballot paper accounts and the sealed packets made up under para. 5.48 above; and
- (k) deliver, or arrange to deliver, to the central counting station the FC ballot box(es), the sealed packets of unissued FC ballot papers etc. and the relevant ballot paper accounts received from the dedicated polling stations.

[Ss 70 and 74AA of the EAC (EP) (LC) Reg] [Added in January 2010 and amended in June 2012 and June 2016]

5.60 If the PRO of a ballot paper sorting station finds any FC ballot paper in a GC ballot box, he/she must:

- (a) sort the FC ballot paper(s) according to each FC;

¹¹ If no electors of a constituency have cast vote in the dedicated polling station(s), no receptacles will be delivered to the relevant main counting station. In that case, the PRO of the main counting station will be notified accordingly.

- (b) count and record the number of FC ballot paper(s) for each FC in the GC ballot box concerned;
- (c) prepare a statement in writing as to the number of ballot paper(s) recorded for each FC under para. 5.60(b) above;
- (d) make into separate bundles the sorted FC ballot paper(s) together with the relevant statement prepared under para. 5.60(c) above ;
- (e) place each bundle in a separate receptacle and seal it in the presence of those present at the counting zone of the ballot paper sorting station; and
- (f) give the receptacles into the charge of an Assistant PRO in attendance at the counting zone of the ballot paper sorting station.

[S 74AB(2) of the EAC (EP) (LC) Reg] *[Added in June 2012]*

5.61 The Assistant PRO shall deliver the receptacles referred to para. 5.60(f) above to the central counting station and hand over the receptacles containing the bundle of FC ballot papers to the RO concerned [s 74AB(3) of the EAC (EP) (LC) Reg]. *[Added in June 2012]*

PART VIII : THE COUNT

Conversion of Polling Station into Counting Station

5.62 A polling station, other than a small polling station or a dedicated polling station, will be converted to a counting station for the purpose of

conducting the count for GC votes and making known the counting results to the candidates and their agents present. Where the same place is designated as both a polling station and a counting station, the PRO of the polling station is to be regarded as the PRO of the counting station [s 34(4) of the EAC (EP) (LC) Reg]. The PRO, assisted by his/her Deputy PROs, Assistant PROs and counting staff, will be responsible for the conversion and the conduct of the count. Before the counting of votes begins, a notice will be displayed outside the counting station to inform the public the time that the station is expected to be open to them to observe the counting of votes [s 65(5A) of the EAC (EP) (LC) Reg]. The telephone number of the counting station should also be shown on such a notice to facilitate communication between the candidates/agents and the station staff. *[Amended in October 2007 and January 2010]*

Central Counting Station

5.63 For FC votes, a central counting station will be set up to conduct the count and announce the election results. The RO for each FC, assisted by his/her AROs and counting staff will be responsible for the conduct of the count.

5.64 An RO will be designated for each of the 5 GCs. The 5 ROs will be stationed at the central counting station. Each RO will be assisted by a number of AROs to compile the final election results of the respective GC by adding up counting results from polling stations under his/her charge. *[Amended in October 2007]*

Conduct at the Counting Station and Central Counting Station

5.65 The following persons may be present at the counting of votes at the counting zone of a counting station or the central counting station:

- (a) the ROs, AROs, PROs, Deputy PROs, Assistant PROs and counting staff for the relevant constituencies;
- (b) the CRO;
- (c) members of the EAC;
- (d) the CEO;
- (e) police officers and members of the CAS on duty at the counting station;
- (f) candidates and their election agents and counting agents of the relevant constituencies;
- (g) public officers authorised in writing by the CEO;
- (h) any person authorised by the CRO, the RO or the PRO; and
- (i) any person authorised in writing by a member of the EAC.

The PRO or the CRO or the RO, as the case may be, will designate a restricted zone inside the counting zone where the counting staff will count the votes. Candidates and their agents must not go into the restricted zone. Any member of the public may observe the counting of the votes from an area (“the public area”) at the counting station set apart for that purpose by the PRO or the CRO or the RO, unless the PRO or the CRO or the RO considers that his/her presence may:

- (a) cause disorder or disturbance in the counting station; or

- (b) prejudice the secrecy of the individual votes.

[S 68 of the EAC (EP) (LC) Reg]

5.66 Before entry, every person authorised to be present at a counting station, other than the police officers and members of the CAS on duty, must make a **Declaration of Secrecy** on a specified attested form and observe the provisions governing the secrecy of voting [s 95 of the EAC (EP) (LC) Reg]. Members of the public present within the public area will not be required to make a Declaration of Secrecy.

5.67 Except with the express permission of the relevant PRO or CRO or RO or a member of the EAC, as the case may be, any person who undertakes photographing, filming and video or audio recording within a counting zone of a counting station during the period commencing from the time at which the counting of the votes is to begin at the zone and ending upon the completion of the counting and re-count, if any, at the zone commits an offence [s 68A(1) and (2) of the EAC (EP) (LC) Reg].

5.68 A person who misconducts himself/herself in or in the vicinity of a counting station or fails to obey any lawful order of the PRO (for counting stations other than the central counting station) or the CRO/RO (for the central counting station) commits an offence and will be liable to a fine at level 2 (\$5,000) and to imprisonment for 3 months and may be ordered by the PRO, or the CRO or the RO as applicable to leave the area immediately. A person misconducts himself/herself if he/she disrupts the counting of votes or disturbs or causes inconvenience to any person in the counting station. The PRO or the CRO or the RO may also order a person to leave the counting station if the person conducts himself/herself in such a way that the purpose of his/her presence is not that for which he/she was authorised or permitted to enter or

remain in the counting station. If he/she fails to leave immediately, he/she may be removed by a police officer or by any other person authorised in writing by the PRO or the CRO or the RO to remove him/her. The person so removed may not re-enter the counting station on that day except with the permission of the PRO or the CRO or the RO [ss 68A and 69 of the EAC (EP) (LC) Reg]. *[Amended in June 2016]*

(a) **Counting of GC votes**

5.69 The PRO of a counting station will conduct the count of the GC ballot papers in the presence of the candidates, their election agents or counting agents, if they are present. The PRO will check whether all the ballot boxes and sealed packets are properly sealed. The seal on each GC ballot box will be broken by the PRO in the presence of the candidates, their election agents or counting agents, if they are present at the time. All GC ballot boxes will then be opened and the contents emptied onto the counting table(s). After the PRO has opened the ballot box, the candidates, their election agents or counting agents may request to inspect any papers other than ballot papers taken out from the ballot boxes before they are disposed of [s 73A of the EAC (EP) (LC) Reg]. If the PRO identifies any misplaced FC ballot papers, the PRO will seal the misplaced FC ballot papers and then arrange to deliver them, together with the sealed FC ballot boxes, to the relevant RO of the central counting station for counting. **At no time should a candidate, his/her election agent or counting agent touch any ballot paper.** *[Amended in January 2010 and June 2016]*

5.70 The PRO who is not a PRO of a main counting station, a small polling station, a dedicated polling station or a ballot paper sorting station shall:

- (a) sort the ballot papers according to the choices marked by the electors on the ballot papers and place them in separate plastic

and transparent boxes on the table;

- (b) separate and put aside the invalid and questionable ballot papers, if any;
- (c) determine the validity of questionable ballot papers;
- (d) count the valid votes obtained by each candidate;
- (e) verify the ballot paper account; and
- (f) compile the final counting results.

[Ss 74A and 75 of the EAC (EP) (LC) Reg] *[Amended in January 2010, June 2012 and June 2016]*

5.71 The PRO of a main counting station shall:

- (a) count and record the number of GC ballot papers in the receptacle(s) received from a ballot paper sorting station (which will be set up in a LegCo general election or, where the CEO considers it appropriate in a LegCo by-election) and verify the respective ballot paper account(s);
- (b) count and record the number of GC ballot papers in the ballot box(es) from designated small polling station and dedicated polling station (in the case of a LegCo by-election in which no ballot paper sorting station has been set up) and verify the respective ballot paper accounts;
- (c) prepare a statement in writing as to the respective result of the

verification in (a) and (b) above;

- (d) mix the ballot papers in at least one of the ballot boxes at the polling station designated as the main counting station together with the ballot papers that have been delivered from the small polling stations and ballot paper sorting stations or dedicated polling stations as the case may be;
- (e) sort the ballot papers according to the choices marked by the electors on the ballot papers and place them in separate plastic and transparent boxes on the table;
- (f) separate and put aside the invalid and questionable ballot papers, if any;
- (g) determine the validity of questionable ballot papers;
- (h) count the valid votes obtained by each candidate;
- (i) verify the ballot paper account in respect of the main counting station concerned;
- (j) prepare a statement in writing as to the result of the verification in (i) above; and
- (k) compile the final counting results.

[Ss 74A and 75 of the EAC (EP) (LC) Reg] *[Amended in January 2010, June 2012 and June 2016]*

Invalid Ballot Papers

5.72 A ballot paper is invalid if:

- (a) no vote has been marked on it;
- (b) it is not marked with the chop provided;
- (c) it is endorsed on the front with the word “SPOILT”;
- (d) it is endorsed on the front with the word “TENDERED”;
- (e) it is endorsed on the front with the word “UNUSED”; or
- (f) votes are given for more than 1 list of candidates for a GC (e.g. by marking a “✓” each against 2 lists of candidates).

[S 80(1) of the EAC (EP) (LC) Reg]

These ballot papers will be set aside as invalid on the spot. They will not be counted and will not be treated as questionable ballot papers. A candidate, an election agent or a counting agent may inspect these ballot papers but is not entitled to make representations to the PRO concerning these ballot papers [s 80(4) of the EAC (EP) (LC) Reg]. *[Amended in October 2007 and July 2008]*

Questionable Ballot Papers

5.73 Ballot papers with doubtful validity in the following categories are set aside as questionable ballot papers. A questionable ballot paper will be decided as invalid if in the opinion of the PRO:

- (a) it has any writing or mark by which the elector can possibly be identified;
- (b) it is not marked by affixing the chop to give a single “✓” in the circle opposite the list of candidates of the elector’s choice on the ballot paper, and the elector’s intention is unclear. However, the PRO may count that ballot paper if he/she is satisfied that the elector’s intention is clear, notwithstanding the “✓” mark is not placed inside the circle; *[Amended in June 2016]*
- (c) it is substantially mutilated; or
- (d) it is void for uncertainty.

[S 81(2) of the EAC (EP) (LC) Reg]

When deciding on the validity of the ballot papers in (a) above, the PRO will make reference to the judgment made by the Court on an election petition case (HCAL 127/2003). In that case, the Court ruled that the handwritten tick found on the ballot paper in question in the said election petition was considered a mark by which the elector could possibly be identified. The validity of ballot papers with any other writing or mark will remain to be determined by the PRO on a case-by-case basis [s 81(3) of the EAC (EP) (LC) Reg]. *[Amended in October 2007 and June 2016]*

5.74 The validity of all questionable ballot papers shall be decided by the PRO [s 81(2) of the EAC (EP) (LC) Reg]. The PRO will invite the candidates, their election or counting agents present to participate in the determination process of questionable ballot paper. *[Amended in June 2016]*

5.75 The determination process will be conducted in the following manner:

- (a) The PRO will inform the candidates and their agents of his/her initial decision on the validity of each questionable ballot paper. A candidate, an election agent or a counting agent, may inspect and make representations concerning any questionable ballot papers [s 81(1) of the EAC (EP) (LC) Reg];
- (b) The PRO will then consider their representations and make his/her final decision on the validity of the questionable ballot paper (see para. 5.76 below) [s 81(2) of the EAC (EP) (LC) Reg];
- (c) If the PRO decides that a questionable ballot paper is invalid and, therefore, not to be counted, he/she must endorse the words “不獲接納” and “rejected” on the front of it. In that case, if a candidate, an election agent or a counting agent objects to that officer’s final decision, that officer must also endorse the words “反對此選票不獲接納” and “rejection objected to” on that ballot paper [s 81(4) of the EAC (EP) (LC) Reg];
- (d) If a candidate, an election agent or a counting agent objects to the decision of the PRO to count a questionable ballot paper, that officer must endorse the words “反對此選票獲接納” and “acceptance objected to” on that ballot paper [s 81(5) of the EAC (EP) (LC) Reg]; and
- (e) The PRO shall prepare a statement to record his/her decisions made in respect of all questionable ballot papers [s 81(6) of the EAC (EP) (LC) Reg].

[Amended in June 2016]

5.76 The decision of the PRO in regard to any question arising in respect of any ballot paper shall be **final** [s 82 of the EAC (EP) (LC) Reg], and may only be questioned by an election petition [s 61 of the LCO] [see Part II of Chapter 6].

5.77 The counting of the votes will proceed continuously, as far as possible, until the counting is completed.

5.78 When vote counting is completed at any one of the counting stations for the constituency, the relevant PRO will inform the candidates or their election or counting agents present of the counting results. Any such candidate or his/her election agent or his/her counting agent may request the PRO to re-count the votes and the PRO shall comply with the request unless in his/her opinion it is unreasonably made. Where there is no request for a re-count or where the request for a re-count is rejected or the re-count is completed and there is no request for a further re-count or the request for a further re-count has been rejected by the PRO, the PRO shall report to an ARO for the constituency at the central counting station of the counting results. Any misplaced GC ballot papers found in FC ballot boxes at the central counting station and delivered to the relevant RO will be counted by the RO. The validity of any questionable ballot papers will be determined by the RO. Candidates, their election agents or counting agents present may raise objection to the acceptance or rejection of a questionable ballot paper. The RO's decision on the validity of the ballot paper is final [s 82 of the EAC (EP) (LC) Reg]. The counting arrangement as set out in paras. 5.72 to 5.76 above will be followed by the RO [s 79A of the EAC (EP) (LC) Reg]. *[Amended in July 2008 and June 2012]*

5.79 After the ARO has been notified of the results of the counting of votes of all the counting stations in the constituency in his/her charge, he/she shall inform the RO for the constituency of the results who shall then inform the candidates or their election agents or counting agents at the central counting station of the results [s 79A(5) of the EAC (EP) (LC) Reg]. If a candidate or his/her election agent at the central counting station requests the RO to re-count all the votes of all the counting stations for the constituency, the RO will decide whether the request should be acceded to. If he/she decides that such a re-count is reasonable in the circumstances, he/she will inform the PROs of all the counting stations for the constituency to conduct a re-count at their respective counting stations [s 79A(6) of the EAC (EP) (LC) Reg].

5.80 When the RO makes known to the candidates or their election agents or counting agents the counting results of all the counting stations for the GC, he/she must also make known to them the estimated number of GC ballot papers estimated to be misplaced in FC ballot boxes (the estimated number will be based on the information in the ballot paper account). Candidates and their election agents may at that point request a re-count of the votes of all counting stations for a GC without having to wait for the counting results of any misplaced GC ballot papers [see para. 5.79 above] [s 79A(7) of the EAC (EP) (LC) Reg]. Alternatively, they may at that point request a re-count of the votes of all the counting stations together with the votes of the misplaced GC ballot papers after the latter votes are counted. The RO will not entertain the alternative request if the estimated number of misplaced GC ballot papers is **less** than the difference between the remaining numbers of votes cast for any two lists of candidates (in which case the counting results of the misplaced GC ballot papers will not affect the overall election results of the GC in question) [s 79A(14) of the EAC (EP) (LC) Reg]. *[Amended in June 2012]*

5.81 The PRO of each of the counting stations will make known the result of the re-count at his/her counting station to the candidates or their

election agents or counting agents present at that counting station and shall report the same to the ARO for the constituency at the central counting station who shall inform the RO for the constituency of the results of the re-count of all the counting stations in his/her charge [s 79A(10) of the EAC (EP) (LC) Reg]. The RO shall add such results and the result of the counting of the votes recorded on the misplaced GC ballot papers found in FC ballot boxes, and shall inform the candidates or their election agents or counting agents present at the central counting station of the aggregate result. If a candidate or his/her election agent requests the RO for a re-count of the votes of the misplaced GC ballot papers, the RO shall comply with the request unless in his/her opinion, it is unreasonably made [s 79A(12) of the EAC (EP) (LC) Reg].
[Amended in July 2008 and June 2012]

5.82 If at any time, it appears to the EAC that a counting station (“first counting station”) assigned for the counting of votes cast at a polling station (“polling station concerned”) in respect of a GC is no longer available or suitable for the counting to take place or continue to take place for reasons other than those referred to in s 2(3) of Schedule 2 to the EAC (EP) (LC) Reg, (*i.e. the occurrences of a typhoon or other climatic condition of a serious nature; riot, open violence or any danger to public health and safety; or an occurrence which appears to the EAC to be a material irregularity relating to the election, the poll or count*), the EAC may direct that the counting is to take place or continue to take place at another counting station (“new counting station”) specified by the CEO [s 75A(1) of the EAC (EP) (LC) Reg]. The RO must give notice to the candidate ranking first in priority on each list of candidates for the constituency of the time and place at which the counting is to take place or continue to take place [s 65(7A) of the EAC (EP) (LC) Reg]. Where such direction is given by the EAC, the PRO of that station must arrange the ballot boxes (whether opened or un-opened) and receptacles, if any, together with the ballot papers (whether counted or not), any un-issued ballot papers, tendered ballot papers, ballot paper account, verification of a ballot

paper account or re-verification of a ballot paper account, and any other relevant election materials to be transferred to the new counting station [s 75A(3) of the EAC (EP) (LC) Reg]. Any person who is entitled to be present at the first counting station or polling station concerned may also be present with the PRO when the PRO makes any of the aforesaid arrangement [s 75A(4) of the EAC (EP) (LC) Reg]. *[Amended in July 2008 and June 2016]*

(b) Counting of FC votes

5.83 The DC (second) FC ballot boxes and the ordinary FC/SFC ballot boxes will be delivered to the central counting station, together with any FC ballot papers found to have been misplaced in GC ballot boxes, and will be given into the charge of the relevant RO [ss 70(1) and 72(1) of the EAC (EP) (LC) Reg]. Each ballot box will then be checked to see if it is properly sealed. The seal on the ballot box will be broken by the relevant RO (or the RO/AROs for the DC (second) FC) [s 92(4) of the EAC (EP) (LC) Reg] in the presence of the relevant candidates or their election agents or counting agents, if they are present at the time [s 73(1) of the EAC (EP) (LC) Reg]. The ballot box will then be opened and the contents emptied onto a counting table. Any misplaced ballot papers (whether GCs, DC (second) FC or other FCs) found will be sealed and then delivered to the RO of the relevant FC and GC for counting. The candidates, their election agents or counting agents may request to inspect any papers, other than ballot papers, taken out from the ballot boxes before they are disposed of. **At no time should a candidate, his/her election agent or counting agent touch any ballot paper.** [S 73(2) of the EAC (EP) (LC) Reg] *[Amended in June 2012 and June 2016]*

5.84 There will be a large number of sorting/counting zones for the FCs. Other than a ballot paper for the DC (second) FC (the counting procedure of which is described in paras. 5.87 and 5.88 below), the ballot papers for the ordinary FCs/SFCs from each of the polling stations will first be

sorted and counted for verification of the ballot paper accounts by the counting staff. Such sorted ballot papers will then be separately bundled with the respective verified ballot paper account. [S 74(1) of the EAC (EP) (LC) Reg] *[Amended in June 2012]*

5.85 As described above, the ordinary FC/SFC ballot papers in each of the sorting/counting zones will be sorted to make up separate bundles for each constituency. Each bundle of ballot papers which is required to be delivered to another sorting/counting zone will be placed in a separate receptacle and sealed under observation by candidates or agents, if any, present at the counting station. Bundles belonging to the same constituency will be allocated to the AROs and their staff for transferring them to the counting zones in respect of the relevant constituency for the counting of votes marked on them under the supervision of the RO of the ordinary FC/SFC. The ballot papers for the same ordinary FC/SFC from not less than 2 of the polling stations will first be mixed before counting [ss 76(3) and 77(3) of the EAC (EP) (LC) Reg]. *[Amended in June 2012 and June 2016]*

5.86 The RO of an ordinary FC/SFC, with assistance of the counting staff, at the counting zone will:

- (a) (i) For SFC
sort the first preference votes marked by the electors on the ballot papers and place them in separate plastic and transparent boxes on the table; or
- (ii) For ordinary FC returning 1 member
sort the votes according to the choices marked by the electors on the ballot papers and place them in separate plastic and transparent boxes on the table; or

- (iii) For ordinary FC returning more than 1 member
record the votes as given to the choices marked by the electors on the ballot papers;
- (b) separate and put aside the invalid and questionable ballot papers, if any;
- (c) determine the validity of questionable ballot papers (by RO);
- (d) (i) For SFC
count the valid votes on the ballot papers in accordance with the preferential elimination system of voting described in s 50 of the LCO; or
- (ii) For ordinary FC
count the valid votes obtained by each candidate; and
- (e) compile the final counting results.

[Please see **Appendix C** for details of the preferential elimination system of voting mentioned in the preceding para. 5.86(d).] [Ss 76 and 77 of the EAC (EP) (LC) Reg] *[Added in June 2012]*

5.87 For DC (second) FC, the votes marked on ballot papers will be counted at the counting zones under the supervision of the RO or AROs of the DC (second) FC. *[Added in June 2012]*

5.88 The AROs of the DC (second) FC, with assistance of the counting staff at counting zones, will:

- (a) for any small polling station or dedicated polling station, count

and record the number of DC (second) FC ballot papers and verify with the respective ballot paper accounts first [s 74AAA(2)(a) of the EAC (EP) (LC) Reg];

- (b) mix those ballot papers from any small polling station or dedicated polling station with the ballot papers in at least one of the ballot boxes from a polling station (other than a small polling station or dedicated polling station) [s 77A(1A) of the EAC (EP) (LC) Reg];
- (c) sort the ballot papers according to the choices marked by the electors on the ballot papers and place them in separate plastic and transparent boxes on the counting tables; separate and put aside the invalid and questionable ballot papers, if any;
- (d) determine the validity of questionable ballot papers (by ARO) [s 77A(4) of the EAC (EP) (LC) Reg];
- (e) count the valid votes obtained by each candidate list;
- (f) verify the number of the DC (second) FC ballot papers recorded in the counting process by comparing the number with the ballot paper account of each polling station (other than a small polling station or a dedicated polling station which is dealt with under (a) above) after the counting of votes [s 74AAA(2)(b) of the EAC (EP) (LC) Reg];
- (g) prepare a statement in writing as to the respective result of the verification in (a) and (f) above [s 74AAA(2)(c) of the EAC (EP) (LC) Reg]; and

- (h) compile the final counting results.

[Ss 74AAA and 77A of the EAC (EP) (LC) Reg] *[Added in June 2012 and amended in June 2016]*

Invalid Ballot Papers

5.89 A ballot paper is invalid if:

- (a) no vote has been marked on it;
- (b) it is endorsed on the front with the word “TENDERED”;
- (c) it is endorsed on the front with the word “SPOILT”;
- (d) it is endorsed on the front with the word “UNUSED”;
- (e) in respect of an ordinary FC and the DC (second) FC ballot paper, it is not marked with the chop provided;
- (f) for an ordinary FC, votes are marked for more than the number of vacancies to be filled (in respect of the Labour FC, a ballot paper is invalid if more than 3 votes are marked on it; in respect of the other 23 FCs, a ballot paper is invalid if more than 1 vote is marked on it);
- (g) for the DC (second) FC, votes are given for more than 1 list of candidates (e.g. by marking a “✓” each against 2 lists of candidates);
- (h) in respect of a SFC ballot paper, it is not marked by Arabic

numerals;

- (i) for a SFC, votes are marked with a first preference for 2 or more candidates (whether or not the elector marks second, third or subsequent preferences); or
- (j) for a SFC, votes are not marked with a first preference (whether or not the elector marks second, third or subsequent preferences).

[S 80(1) of the EAC (EP) (LC) Reg]

Ballot papers from (a) to (j) will be set aside as invalid on the spot. They will not be counted and will not be treated as questionable ballot papers. A candidate, an election agent or a counting agent may inspect these ballot papers but is not entitled to make representations to the RO concerning these ballot papers [s 80(4) of the EAC (EP) (LC) Reg]. *[Amended in October 2007, July 2008 and June 2012]*

Questionable Ballot Papers

5.90 Other ballot papers with doubtful validity in the following categories are set aside as questionable ballot papers. A questionable ballot paper will be decided as invalid if in the opinion of the RO:

- (a) it has any writing or mark by which the elector/AR can possibly be identified;
- (b) for an ordinary FC/DC (second) FC, the vote is not marked by affixing the chop to mark a single “✓” in the circle opposite the name of the candidate/list of candidates in respect of the DC (second) FC of the elector’s/AR’s choice on the ballot paper, and the elector’s/AR’s intention is unclear. For a SFC, the Arabic

numeral is not entered in the circle opposite the name of the candidate of the elector's/AR's choice on the ballot papers and the elector's/AR's intention is unclear. However, the RO may count that ballot paper if he/she is satisfied that the elector's/AR's intention is clear, notwithstanding the "✓" mark or the Arabic numeral are not placed inside the circle; *[Amended in July 2008, June 2012 and June 2016]*

- (c) it is substantially mutilated; or
- (d) it is void for uncertainty.

Regarding the validity of the ballot papers in (a) above, please also refer to the court judgment on an elector petition case (HCAL 127/2003) referred to in para. 5.73 above [s 81(2) and (3) of the EAC (EP) (LC) Reg]. *[Amended in July 2008 and June 2012]*

5.91 For a SFC, where an elector marks on his/her ballot paper the same preference for two or more candidates, only the preference vote or votes prior in sequence to that preference shall be valid. Where an elector marks on his/her ballot paper preferences which are not in a consecutive sequence, only the preference vote or votes which appear before the break in sequence shall be valid. *[Amended in June 2016]*

5.92 The validity of all questionable ballot papers shall be decided by the RO of the relevant constituency. The RO will invite the candidates, their election or counting agents present to participate in the process. *[Amended in June 2016]*

5.93 The determination process will be conducted in the following manner:

- (a) the RO will inform the candidates and their agents of his/her initial decision on the validity of each questionable ballot paper. A candidate, an election agent or a counting agent if present at the counting zone, may inspect and make representations concerning any questionable ballot paper [s 81(1) of the EAC (EP) (LC) Reg];
- (b) the RO will then consider their representations and make his/her final decision on the validity of the questionable ballot paper (see para. 5.94 below) [s 81(2) of the EAC (EP) (LC) Reg];
- (c) if the RO decides that a questionable ballot paper is invalid and, therefore, not to be counted, he/she must endorse the word “不獲接納” and “rejected” on the front of it. In that case, if a candidate, an election agent or a counting agent objects to the RO’s final decision, the RO must also endorse the words “反對此選票不獲授納” and “rejection objected to” on that ballot paper [s 81(4) of the EAC (EP) (LC) Reg];
- (d) if a candidate, an election agent or a counting agent objects to the decision of the RO to count a questionable ballot paper, the RO must endorse the words “反對此選票獲接納” and “acceptance objected to” on that ballot paper [s 81(5) of the EAC (EP) (LC) Reg]; and
- (e) the RO shall prepare a statement to record his/her decisions made in respect of all questionable ballot papers [s 81(6) of the EAC (EP) (LC) Reg].

[Added in June 2016]

5.94 The decision of the RO in regard to any question arising in respect of any ballot paper shall be **final** [s 82 of the EAC (EP) (LC) Reg], and may only be questioned by an election petition [s 61 of the LCO] [see Part II of Chapter 6].

5.95 The counting of the votes will proceed continuously, as far as possible, until the counting is completed.

5.96 When vote counting is completed for the relevant constituency of the FC, the relevant RO will inform the candidates, their election or counting agents present of the counting result [s 79(1) of the EAC (EP) (LC) Reg]. Any such candidate or his/her election agent may request the RO to re-count the votes and the RO shall comply with the request unless in his/her opinion it is unreasonably made [s 79(2) of the EAC (EP) (LC) Reg]. Where there is no request for a re-count or where the request for a re-count is rejected or the re-count is completed and there is no request for a further re-count or the request for a further re-count has been rejected by the RO, the RO will inform the candidates and their agents of the counting results [s 79 of the EAC (EP) (LC) Reg].

Counting arrangements for the by-election in respect of the DC (second) FC

5.97 If the polling day of a by-election held for DC (second) FC does not fall on the polling day of a by-election held for any GC, the same arrangement for counting the GC ballot papers for a LegCo by-election in which no ballot paper sorting station has been set up as set out in paras. 5.48 to 5.52 and paras. 5.62 to 5.82 above will be adopted to count the ballot papers of the aforesaid DC (second) FC. Under such circumstances, the polling stations (except small polling stations and dedicated polling stations) will be converted into counting stations for counting of votes. The relevant PROs will supervise

the count and determine the validity of the ballot papers. If a by-election for the DC (second) FC and that for any GC are to be held on the same day, the ballot papers of the DC (second) FC would be delivered to the central counting station for counting as in the LegCo general election. [Ss 77B and 92 of the EAC (EP) (LC) Reg] *[Added in June 2012]*

PART IX : DECLARATION OF RESULT

(a) For GCs and the DC (second) FC

5.98 Where the count is to be conducted at the individual polling stations (as in the case for a GC election or a DC (second) FC by-election), the PRO of each of the counting stations shall report to an ARO for the constituency the final counting or re-count result of his/her counting station; where the count is to be conducted at a central counting station (as in the case of a DC (second) FC election), the Counting Supervisor of each of the counting zone in the central counting station shall report to the ARO of the constituency. After tallying the total of the final counting or re-count results with all the final counting or re-count results reported from individual counting stations/counting zones for the constituency, the RO shall apply the list system of proportional representation and accordingly declare the successful candidates as elected [s 83 of the EAC (EP) (LC) Reg]. *[Amended in June 2012 and June 2016]*

5.99 In the event that 2 or more lists have the equal largest number of remaining votes and the number of those lists exceeds the number of vacancies to be filled, the RO shall determine the result of the election by drawing lots at the central counting station. He/She shall use the means of contact of such candidates provided in their nomination forms to request them to be present at the central counting station for conducting the drawing of lots and such list of candidates shall comply as soon as possible. If the RO fails to contact such a

list of candidates, the RO may draw lots on behalf of the list of candidates [see para. 2.26 for detailed procedures for drawing of lots]. He/She shall declare the candidate on whose list the lot falls as elected. He/She shall display a notice of the result of the election at a prominent place outside the central counting station and shall also publish the notice in the Gazette within 10 days of the declaration of the result [ss 83 and 84 of the EAC (EP) (LC) Reg].

(b) For Ordinary FCs/SFCs

5.100 When the counting of votes and re-counts, if any, are completed and a result obtained, the RO for the relevant constituency shall declare the successful candidate(s) elected for the constituency concerned. In respect of the ordinary FCs, in the event that a vacancy is still to be filled for a constituency and the most successful candidates have an equal number of votes, the RO will determine the result of the election by drawing lots at the central counting station. For the SFC, if the remaining candidates after the final stage of counting have an equal number of votes, the RO will determine the result of the election by drawing lots at the central counting station [see para. 2.26 for detailed procedures for drawing of lots]. He/She shall declare the candidate on which the lot falls as elected. The RO for the relevant constituency shall display a notice of result of the election of the constituency in a prominent place outside the central counting station. The result of the election will also be published in the Gazette within 10 days of the declaration of the result [ss 83 and 84 of the EAC (EP) (LC) Reg]. *[Amended in July 2008 and June 2012]*

PART X : DISPOSAL OF DOCUMENTS

5.101 As soon as practicable after the RO/PRO has ascertained the result of the poll in an election, he/she shall seal all the relevant documents and ballot papers into packets. Candidates and their agents may observe the

packaging, if they so wish [s 85(1) and (3) of the EAC (EP) (LC) Reg].
[Amended in June 2012]

5.102 These sealed packets, together with other documents including the nomination forms, notices of appointment of agents, etc. will be sent to the CEO for safe custody for at least 6 months before they are destroyed [ss 86(1) and 88 of the EAC (EP) (LC) Reg]. *[Amended in June 2012]*

5.103 **Except pursuant to a court order** in relation to an election petition or criminal proceedings, **no person may inspect any ballot paper in the custody of the CEO** [s 87 of the EAC (EP) (LC) Reg].

CHAPTER 6

ELECTION PETITIONS

PART I : GROUNDS FOR LODGING AN ELECTION PETITION

6.1 The result of the LegCo election may be questioned only by an election petition made on the following grounds:

- (a) the ground that the person declared as elected by the RO in accordance with regulations in force under the EACO was not duly elected because:
 - (i) he/she was not eligible to be, or was disqualified from being, a candidate at the election; or
 - (ii) he/she engaged in corrupt or illegal conduct at the election; or
 - (iii) corrupt or illegal conduct was generally prevalent at the election; or
 - (iv) material irregularity occurred in relation to the election, the poll at the election or the count of votes in respect of the election; or
- (b) a ground specified in any other enactment that enables an election to be questioned.

PART II : WHO COULD, AND WHEN TO, LODGE ELECTION PETITIONS

6.2 An election petition may be lodged, in the case of an election for a constituency:

- (a) by 10 or more electors entitled to vote at the election for the relevant constituency; or
- (b) by a person claiming to have been a candidate in the election for the relevant constituency.

[S 62(1) of the LCO]

6.3 An election petition questioning an election may be lodged with the Court of First Instance (“CFI”) only during the period of 2 months following the date on which the RO has published the result of the election in the Gazette [s 65(1) of the LCO].

6.4 An election petition is triable in open court and before a single judge. At the end of the trial of an election petition, the CFI must determine questions of the validity of a nomination or whether the person was or was not duly elected, as appropriate. The CFI must announce its determination by means of a written judgment. [Ss 64(2) and 67(1), (2) and (3) of the LCO] *[Amended in October 2007 and June 2012]*

6.5 An appeal against the decision of the CFI may be lodged to the Court of Final Appeal (“CFA”) direct, subject to leave being granted by the Appeal Committee of the CFA. Notice of a motion for applying for leave to the CFA to appeal must be filed within 14 working days after the date on which the written judgment of the CFI to be appealed against is handed down, and the applicant must give the opposite party 3 days’ notice of his/her intended

application at any time during the period of 14 working days. At the end of the hearing of an appeal against the determination of the CFI, the CFA must determine questions of the validity of a nomination or whether the person was or was not duly elected, as appropriate. The CFA must announce its determination by means of a written judgment. [Ss 65(2) and 70B of the LCO]
[Added in June 2012]

CHAPTER 7

APPOINTMENT AND ROLES OF ELECTION AGENT, ELECTION EXPENSE AGENTS, POLLING AGENTS AND COUNTING AGENTS

PART I : GENERAL

7.1 This chapter deals with the appointment of agents at an election and their roles.

7.2 The law and guidelines referred to in this chapter apply to candidates/candidates on lists of candidates in a GC/DC (second) FC election as they apply to candidates in a traditional FC election. Wherever there are special features applicable only to a **list of candidates**, they will be expressed in the relevant context. *[Amended in June 2012]*

7.3 A candidate should think carefully before selecting any of his/her agents. He/She should choose persons suitable for the task. They will be viewed as his/her representatives and their conduct may affect the public's perception of him/her and his/her election.

PART II : TYPES AND NUMBERS OF AGENTS

7.4 A candidate/list of candidates may appoint the following agents to assist him/her/them in an election:

- (a) 1 election agent [s 23(1), (2) and (3) of the EAC (EP) (LC) Reg];

- (b) **any number** of election expense agents;
- (c) not more than **2** polling agents for **each polling station** other than a dedicated polling station situated in a prison in respect of the GC, the ordinary FC, the DC (second) FC or SFC for which he/she is nominated [s 42(3), (4), (5) and (8A) of the EAC (EP) (LC) Reg]; *[Amended in June 2012]*
- (d) **1** polling agent for **each dedicated polling station** situated in a prison other than a maximum security prison [s 42(8A)(a) and (c) of the EAC (EP) (LC) Reg]; and

(Only candidates themselves may enter maximum security prison (see para. 7.26 below) For arrangements regarding admission of election agents or polling agents to dedicated polling stations situated in prisons, please refer to paras. 7.13 to 7.16 and paras. 7.25 to 7.27 below.)

- (e) not more than such number of counting agents as will be specified by the EAC¹² [s 66(2) of the EAC (EP) (LC) Reg]. *[Amended in June 2016]*

[Amended in January 2010, June 2012 and June 2016]

PART III : QUALIFICATIONS OF AGENTS

7.5 The election, polling and counting agents should be holders of Hong Kong identity card and have attained the age of 18 years [ss 23(5), 42(7) and 66(4) of the EAC (EP) (LC) Reg] while an election expense agent needs to

¹² The number of counting agents to be specified by the EAC will be stated in the specified form for the appointment of counting agents.

be a person who has attained the age of 18 years [s 25(5) of the EAC (EP) (LC) Reg].

PART IV : CIVIL SERVANTS ACTING AS AGENTS

7.6 Civil servants, other than directorate officers, Administrative Officers, Information Officers and Police Officers and those officers acting in the above grades or ranks with a view to substantive appointment thereto, (i.e. other than acting for temporary relief purpose), may act as agents or assist in electioneering activities **provided that** they are not already appointed as the CRO, ROs, AROs, PROs, polling or counting staff, that there is no conflict of interest with their official duties, that no use of public resources is involved, and that no government uniform is worn. To avoid any unfairness or appearance of unfairness or conflict of interest, civil servants who work in a constituency or have extensive contacts with the public in a constituency are strongly advised not to accept appointment by a candidate in that constituency to be his/her agent and/or participate in electioneering activities in the constituency concerned. Civil servants who participate in electioneering activities, including the seeking of election donations, for any candidates should not use or give the impression of using any public resources in such activities. The guidelines set out in this paragraph are equally applicable to the non-civil service contract staff of the Government. *[Amended in October 2007 and June 2012]*

PART V : ELECTION AGENT

Appointment

7.7 A candidate/list of candidates may appoint **1** election agent to assist him/her/them and to act on his/her/their behalf in an election [s 23(1), (2)

and (3) of the EAC (EP) (LC) Reg]. The appointment may be made at any time after a candidate hands in his/her own nomination form.

7.8 The candidate must give notice of such appointment to the RO for the relevant GC or FC for which the candidate is nominated [s 23(6) of the EAC (EP) (LC) Reg]. The notice must be in the specified form, signed by both the candidate and the agent, and delivered by hand, by electronic mail, by facsimile transmission or by post to the RO (in the case of a list of candidates, the notice must be signed by all the candidates on the list and be given to the RO by any one of the candidates on the list). If the notice of appointment is given on the polling day, it should not be delivered to the RO by post. [S 23(6), (9) and (16) of the EAC (EP) (LC) Reg] The appointment will not be effective until the notice of appointment is received by the RO [s 23(7) of the EAC (EP) (LC) Reg]. *[Amended in June 2016]*

7.9 Expenses incurred by any purported agent before the notice of appointment is received for promoting the election of a candidate or for prejudicing the election of another candidate or other candidates may, depending on the circumstances, still be treated as the election expenses incurred in respect of the candidate. It is **important** to note that it is an **illegal conduct** for any person other than a candidate or a candidate's election expense agent to **incur election expenses at or in connection with an election** [s 23(1) of the ECICO]. An election agent must not incur election expenses for or on behalf of a candidate unless he/she has been appointed as an election expense agent. *[Amended in June 2016]*

Revocation

7.10 The appointment of an election agent may be revoked by the candidate (or in the case of a list of candidates, all the candidates on the list) at any time. The candidate must also give notice of the revocation in writing in the specified form and deliver the signed notice by hand, by electronic mail, by

facsimile transmission or by post to the RO. In the case of a list of candidates, a notice of revocation must be signed by all the candidates on the list and be given to the RO by any one of the candidates on the list. If the notice of revocation is given on the polling day, it should not be delivered to the RO by post. A revocation of an appointment of an election agent will not be effective until such notice is received by the RO. [S 23(9), (11), (12), (13) and (16) of the EAC (EP) (LC) Reg] *[Amended in June 2012 and June 2016]*

7.11 If an election agent passes away or has his/her appointment revoked, the candidate may appoint another election agent. In such a case, the candidate must give notice of the replacement appointment in the specified form to the RO in accordance with para. 7.8 above. In the case of a list of candidates, all the candidates on the list may jointly appoint a replacement. [S 23(14), (15) and (16) of the EAC (EP) (LC) Reg] Like other election agents, the new election agent has to follow the arrangements set out in paras. 7.13 to 7.16 below, including the need to submit an application to the CEO if he/she wishes to observe the poll at a dedicated polling station situated in a prison (other than a maximum security prison). *[Amended in January 2010]*

Notification

7.12 Not later than 10 days after the end of the nomination period, and thereafter as required, each validly nominated candidate/list of candidates or his/her/their election agent will receive from the RO a notice containing the particulars of all the election agents (such as names and correspondence addresses) appointed by all candidates for the constituency concerned. In the case of a list of candidates, the RO must send the notice to the candidate ranking first in priority on the list or the election agent of the list. [S 24(1), (2), (4), (5) and (6) of the EAC (EP) (LC) Reg] The RO must also display outside his/her office a notice of the particulars of the election agents [s 24(7) of the EAC (EP) (LC) Reg]. *[Amended in June 2012]*

Role of an Election Agent

7.13 A duly appointed election agent ranks in the **most important position** amongst all kinds of agents of a candidate. He/She has the **authority to do everything a candidate is authorised to do under the EAC (EP) (LC) Reg** for the purposes of the election **except**:

- (a) to sign the nomination form or make any requisite declaration or promissory oath in relation to a candidate's nomination;
- (b) to withdraw the candidate's candidature;
- (c) to incur election expenses save where he/she has been appointed as an election expense agent by the candidate;
- (d) to authorise an election expense agent to incur election expenses;
and
- (e) to be present in a dedicated polling station situated in a maximum security prison.

[S 23(17) and (18) of the EAC (EP) (LC) Reg] *[Amended in October 2007, January 2010 and June 2016]*

IMPORTANT :

An election agent is, along with the candidate, responsible for the management of the election campaign. A candidate is responsible for all the acts of his/her or his/her list's election agent. If the election agent fails in his/her duties, he/she may contravene the law, in particular, the ECICO, and may commit criminal offences for which the candidate may also be liable, with

serious consequences. An election agent will need to be authorised as an election expense agent by a candidate to incur election expenses. If so authorised, the election agent becomes also an election expense agent. [See Part VI of this chapter.]
[Amended in June 2012]

7.14 Candidates and their election agents are allowed admission to all polling stations in respect of the constituency concerned and are entitled to be present at the counting of the votes. Due to security reasons, only candidates may enter dedicated polling stations situated in maximum security prisons to observe the poll. An election agent, who wishes to observe the poll at a dedicated polling station situated in a prison other than a maximum security prison, must deliver an application in the specified form to the CEO by hand, by post, by electronic mail or by facsimile transmission at least 1 week before the polling day. The election agent may not be present at that dedicated polling station unless the Commissioner of Correctional Services has given consent to his/her presence. If the Commissioner of Correctional Services refuses to give consent to the application received, he/she will notify the candidate, any candidate on the list of candidates or the election agent as soon as practicable. [S 23(18) and (21) of the EAC (EP) (LC) Reg] *[Amended in January 2010 and June 2016]*

7.15 The Commissioner of Correctional Services may, on an application delivered to the CEO during the week before the polling day, give consent if he/she is satisfied that a person imprisoned or held in custody by the CSD, who is entitled to vote for the relevant constituency at the dedicated polling station concerned, is admitted or transferred to the prison concerned during that week and the application is made without undue delay after the admission or transfer [s 23(20) of the EAC (EP) (LC) Reg]. The REO will post and update on its website the number of registered electors who are imprisoned or held in custody in individual prisons daily from Monday to Friday (other than a general holiday) starting from three weeks before the

polling day and on the Saturday immediately before the polling day for candidates' reference. *[Added in January 2010 and amended in June 2016]*

7.16 No election agent may be present at a dedicated polling station situated in a prison if a polling agent has already been appointed by the same candidate or the same list of candidates for that polling station [s 23(19) of the EAC (EP) (LC) Reg]. *[Added in January 2010]*

7.17 The PRO of a polling station may regulate the number of candidates and their agents to be admitted to the polling station at any one time, for the purpose of maintaining order in the polling station and ensuring that polling is conducted smoothly [s 44(2) of the EAC (EP) (LC) Reg]. **Whilst inside a polling station, a counting station or a ballot paper sorting station, the provisions to be observed by polling agents and counting agents are also applicable to candidates and their election agents.** They are therefore advised to familiarise themselves also with the guidelines set out in Parts VII and VIII of this chapter. *[Amended in January 2010]*

PART VI : ELECTION EXPENSE AGENTS

Authorisation

7.18 A candidate may authorise **any number** of election expense agents to incur election expenses on his/her behalf in an election. The authorisation will remain in force until the end of the election period, i.e. the end of the polling day or the last polling day if there is more than 1 polling day [ss 2 and 23 of the ECICO]. All the candidates on a GC/DC (second) FC list must jointly authorise the election expense agent to incur election expenses on behalf of the list, for any expenditure incurred for promoting the election of any candidate on the GC/DC (second) FC list or for prejudicing the election of another candidate/list of candidates must necessarily be incurred for the

promotion or benefit of all candidates on the whole list [s 25(8) of the EAC (EP) (LC) Reg]. Each candidate on the GC/DC (second) FC list must mutually authorise the other fellow candidate(s) on the same GC/DC (second) FC list as his/her election expense agent(s), or otherwise none of the other fellow candidates can lawfully incur election expenses for him/her, or for the whole list which includes him/her [s 23(2) of the ECICO]. For details of the special features applicable to a list of candidates, see Part VII of Chapter 16. *[Amended in October 2007 and June 2012]*

7.19 The authorisation shall be in writing on a specified form and state the name, identity document number and residential address of the election expense agent, and must specify the maximum amount of election expenses the agent may incur [s 25(6) and (7) of the EAC (EP) (LC) Reg]. It should be signed by both the candidate (in the case of a list of candidates, by all the candidates on the list) and the agent [s 25(8) of the EAC (EP) (LC) Reg]. A copy of the authorisation must be delivered by hand, by post, by electronic mail or by facsimile transmission to the RO for the constituency, or the CEO if the RO has not been appointed [s 25(9) and (10) of the EAC (EP) (LC) Reg]. *[Amended in June 2012 and June 2016]*

7.20 The authorisation is not effective until it has been received by the RO or the CEO as the case may be [s 25(11) of the EAC (EP) (LC) Reg]. Before the authorisation is received, no election expenses should be incurred by a person purporting to be authorised as an election expense agent. It is also important to note that it is an illegal conduct for any person other than a candidate or a candidate's election expense agent to incur such expenses [s 23(1) of the ECICO]. The expenses so incurred may also be counted as the candidate's election expenses.

Revocation

7.21 The authorisation of an election expense agent may be revoked

by a candidate (or in the case of a list of candidates, by all the candidates on the list) at any time. The candidate must give notice of the revocation as soon as possible in writing in the specified form and deliver the signed notice by hand, by post, by electronic mail or by facsimile transmission to the RO, or the CEO if the RO has not been appointed. In the case of a list of candidates, the notice must be signed by all the candidates on the list and be given by any one of the candidates on the list. [S 25(14), (15) and (15A) of the EAC (EP) (LC) Reg] The revocation will only be effective when the RO or the CEO, as the case may be, receives the notice [s 25(16) of the EAC (EP) (LC) Reg]. The election expenses already incurred will still be counted as election expenses of the candidate/list of candidates. *[Amended in October 2007, June 2012 and June 2016]*

Role of Election Expense Agents

7.22 An election expense agent is authorised **to incur election expenses on behalf of a candidate**. He/She must not incur election expenses in excess of the amount specified in the form of authorisation; otherwise he/she commits a criminal offence [s 23(4) of the ECICO].

Candidate's Duty to Know the Details of Election Expenses Incurred by his/her Election Expense Agents

7.23 Every candidate is under a **duty**, subject to criminal penalty for breach, to submit to the CEO a return and declaration of his/her election expenses and election donations (thereafter referred to as "election return") with supporting invoices and receipts issued by recipients of the payments. The candidate must ensure that the election return is lodged before the expiry of the period of 60 days after the date on which the last of the following events occurs in relation to the election –

- (a) the result of the election is notified in the Gazette;

- (b) the proceedings for the election are declared to have been terminated;
- (c) the election is declared to have failed,

or within such extended period as may be allowed by the CFI under the relevant law [s 37(1B), (1C) and (1N) of the ECICO and Part IV of Chapter 16]. For the efficient and effective discharge of his/her duty, the candidate should **make sure** that his/her election expense agents will keep account of all election expenses incurred on his/her behalf and will provide to him/her, as soon as practicable but not later than the same period, a detailed statement of expenditure in which each item of expenditure of \$100 or above has to be supported by an invoice and a receipt. If any item of expenditure incurred by the election expense agents is paid or defrayed or contributed to by a donation, the candidate should **make sure** that they will provide him/her with a statement stating the expenses. If an item is not explicit in monetary terms, it should be assessed at a reasonable value; and if any item of donation is more than \$1,000, it should be supported by a copy of the receipt issued to a donor (in a standard form signed by the donor). Without such statements, invoices and receipts issued by recipients of the payments or to donor(s), as the case may be, provided by the election expense agents, the candidate will no doubt have difficulty in discharging his/her duty to file the election return, which **may render him/her liable for a criminal offence** under s 38 of the ECICO.

[Amended in October 2007, June 2012 and June 2016]

Public Inspection of Authorisation of Election Expense Agents

7.24 The RO or the CEO, as the case may be, will make available for public inspection all copies of authorisations of election expense agents submitted by candidates until the expiration of the period for which copies of the election return lodged by the candidates are available for inspection, (i.e.

the period ending with the 60th day before the first anniversary of the date of the deadline for lodging the relevant election return) (disregarding any order made by the CFI under s 40 of the ECICO allowing a candidate to lodge an election return within a further period as specified by the CFI) [s 41(6) of the ECICO]. This offers the public and other candidates an opportunity to scrutinise the maximum amount of election expenses that could be incurred by the election expense agents on behalf of the candidates. [S 26 of the EAC (EP) (LC) Reg] *[Amended in June 2012 and June 2016]*

PART VII : POLLING AGENTS

Appointment

7.25 A candidate/list of candidates may appoint **not more than 2 polling agents** for each polling station, other than a dedicated polling station situated in a prison, in respect of the constituency for which he/she is nominated [s 42(3), (4), (5) and (8A) of the EAC (EP) (LC) Reg]. The notice of appointment must be in writing, in the specified form, signed by the candidate and delivered by hand, by post, by electronic mail or by facsimile transmission to the CEO, at least **7 days** before the polling day. In the case of a list of candidates, the notice must be signed by all the candidates on the list and be given to the CEO by any one of the candidates on the list. [S 42(8), (8AA) and (11) of the EAC (EP) (LC) Reg] Where a candidate wishes to appoint a polling agent after the above deadline, he/she is required to give notice of the appointment to the PRO of the polling station for which that agent has been appointed. Such a notice must be given by the candidate (or in the case of a list of candidates, any one of the candidates on the list) or the election agent **in person** by delivering the notice of appointment to the PRO at the relevant polling station on the polling day [s 42(9) of the EAC (EP) (LC) Reg]. The appointment will not be effective until the notice of appointment is received by the CEO or the PRO, as the case may be [s 42(10) of the EAC (EP)

(LC) Reg]. *[Amended in January 2010, June 2012 and June 2016]*

7.26 In respect of the appointment of polling agent to be admitted to a dedicated polling station situated in prison, the following provisions would apply:

- (a) only the candidate or any one of the candidates on a list of candidates is allowed to be present in a dedicated polling station situated at a maximum security prison [s 42(8A)(c) of the EAC (EP) (LC) Reg];
- (b) only 1 polling agent may be appointed for a dedicated polling station situated in a prison which is not a maximum security prison and the Commissioner of Correctional Services has given consent to the presence of the agent [s 42(8A)(a) of the EAC (EP) (LC) Reg]. The appointment is effective only when an application made in a specified form is delivered to the CEO by hand, by post, by electronic mail or by facsimile transmission at least **7 days** before the polling day [s 42(8), (8AA) and (8A) of the EAC (EP) (LC) Reg]. In the case of a list of candidates, the notice must be signed by all the candidates on the list and be given to the CEO by any one of the candidates on the list [s 42(11) of the EAC (EP) (LC) Reg]; and
- (c) for a dedicated polling station situated in a prison which is not a maximum security prison, no polling agent may be appointed if the Commissioner of Correctional Services has already given consent to the presence of the election agent of the same candidate/list of candidates at that polling station [s 42(8A)(b) of the EAC (EP) (LC) Reg].

[Amended in January 2010, June 2012 and June 2016]

7.27 If the Commissioner of Correctional Services refuses to give consent to the application received, he/she will notify the candidate, any candidate on the list of candidates or the election agent as soon as practicable [s 42(8C) of the EAC (EP) (LC) Reg]. The Commissioner of Correctional Services may, upon receipt of a notice of appointment given during the week before the polling day, still give consent if he/she is satisfied that a person imprisoned or held in custody by the CSD, who is entitled to vote for the relevant constituency at the polling station concerned, is admitted or transferred to the prison concerned during that week and that the application is given without undue delay after the admission or transfer [s 42(8B) of the EAC (EP) (LC) Reg]. The REO will post and update on its website the number of registered electors who are imprisoned or held in custody in individual prisons on every Monday to Friday (other than a general holiday) starting from 3 weeks before the polling day and on the Saturday immediately before the polling day for candidates' reference. *[Added in January 2010 and amended in June 2016]*

Revocation

7.28 The appointment of a polling agent may be revoked by the candidate (or in the case of a list of candidates, by all the candidates on the list) at any time. The candidate (or in the case of a list of candidates, any one of the candidates on the list) must give notice of revocation in writing in the specified form and deliver the signed notice by hand, by post, by electronic mail or by facsimile transmission to the CEO (other than on the polling day). In the case of a list of candidates, the notice must be signed by all the candidates on the list. If the notice of revocation is given on the polling day:

- (a) for a polling agent appointed for a polling station other than a dedicated polling station situated in a prison, such notice must be delivered to the relevant PRO by either the candidate (or in the

case of a list of candidates, by any candidate on the list) or the election agent **in person**;

- (b) for a polling agent appointed for a dedicated polling station situated in a prison, such notice must be delivered to the CEO by hand, by electronic mail or by facsimile transmission.

[S 42(13), (14) and (14A) of the EAC (EP) (LC) Reg] *[Amended in June 2016]*

7.29 A revocation of an appointment of a polling agent is not effective until the notice thereof is received by the CEO or the PRO, as the case may be [s 42(15) of the EAC (EP) (LC) Reg]. If a replacement of polling agent is appointed and he/she wishes to observe the poll at a dedicated polling station in a prison (other than a maximum security prison), he/she is required to follow the arrangements set out in paras. 7.25 to 7.27 above. *[Amended in January 2010 and June 2012]*

Role of Polling Agents

7.30 Polling agents are appointed **to assist a candidate in observing the conduct of the poll**, to detect impersonation or irregularity at polling stations.

Provisions which the Polling Agents should be Aware of

7.31 On behalf of each candidate/list of candidates, only 1 polling agent may be admitted at any one time to the polling station for which he/she has been appointed [s 44(6) of the EAC (EP) (LC) Reg]. He/She is required to stay and keep his/her movements within the area designated for observation of the poll and not outside. Where a candidate or his/her election agent is present within a polling station, a polling agent of that candidate/list of candidates will not be allowed to be present at the same time within the polling

station [s 44(7) and (8) of the EAC (EP) (LC) Reg]. [See also Part IV of Chapter 5 regarding the admission of candidates, election agents and polling agents to the polling station.] *[Amended in January 2010 and June 2012]*

7.32 Before entering a polling station, every person, other than an elector/AR, a police officer, an officer of the CSD, an officer of any law enforcement agency or a member of the CAS on duty, must make a Declaration of Secrecy on a specified form and observe the provisions governing the secrecy of voting [s 95(1), (2) and (5) of the EAC (EP) (LC) Reg]. This is to make sure that, subject to penalty of making a false declaration, all persons inside a polling station will observe the secrecy of the vote of the elector and, in particular, not to divulge which elector/AR has voted for which candidate and/or list of candidates. *[Amended in January 2010 and June 2012]*

7.33 On attending the polling station for which he/she has been appointed, a polling agent shall report to the PRO and produce his/her identity card and the Declaration of Secrecy completed by him/her for inspection [s 44(10) of the EAC (EP) (LC) Reg].

7.34 The following procedures shall apply on the polling day:

(a) Before the poll

- (i) About 15 minutes before the commencement of the poll, the PRO will inform the candidates or their agents (either election agent or polling agent) if they are present, of the number of ballot papers in the PRO's possession, showing them the books of ballot papers not yet issued to any elector/AR (“**UNISSUED** ballot papers”).
- (ii) The PRO will show the empty ballot boxes to such persons before proceeding to lock and seal them.

(b) During the poll

- (i) Where a person, claiming to be a particular elector/AR entered on the register, applies for a ballot paper after a person has already been issued with a ballot paper under the name of such an elector/AR, the PRO may issue a tendered ballot paper to the latter elector/AR **only if** he/she is not certain that the latter person is the former person who had been issued with a ballot paper earlier, and the latter person has answered the appropriate questions in accordance with the law as set out in para. 5.27 to the satisfaction of the PRO. The PRO will in such circumstances issue a ballot paper with the word **“TENDERED”** endorsed on the front. Such a ballot paper shall not be counted at the counting of the votes. [Ss 60(1) and 80(1)(b) of the EAC (EP) (LC) Reg]
- (ii) Any elector/AR who has inadvertently torn or damaged any ballot paper or has made an error in marking any ballot paper issued to him/her may ask the PRO to exchange it for another ballot paper. If the PRO considers the request reasonable, he/she will issue a new ballot paper to the elector in exchange for the spoilt one. The PRO shall endorse on the front of such spoilt ballot paper with the word **“SPOILT”** and keep it in his/her own custody. The spoilt ballot paper will not be put into a ballot box and will not be counted at the counting of votes. [Ss 62 and 80(1)(c) of the EAC (EP) (LC) Reg]
- (iii) The PRO shall endorse on the front of any abandoned ballot papers that have been issued or any torn pieces of

such ballot papers found lying anywhere in the polling station with the word “**UNUSED**” and keep them in his/her own custody. Such ballot papers shall not be put into a ballot box and will not be counted at the counting of votes. [Ss 61 and 80(1)(d) of the EAC (EP) (LC) Reg] Under these circumstances, the PRO will show to each candidate or his/her election agent or polling agent, who is present at the relevant time, such ballot papers.

(c) After the poll

- (i) The PRO shall, in the presence of persons at the polling station, lock the flap on the lid of the ballot boxes and seal it. He/She will also inform each candidate or his/her agent, if present, of the number of the following types of ballot papers in his/her possession: unissued ballot papers, unused ballot papers, and spoilt ballot papers [s 63(2) of the EAC (EP) (LC) Reg].
- (ii) For GCs, candidates, their election agents, polling and counting agents, if present, may stay inside the polling station to observe the conversion of the venue into a counting station [s 63(1A) of the EAC (EP) (LC) Reg]. The count will commence upon the completion of the conversion. *[Amended in July 2008]*
- (iii) For FCs, up to 2 persons being candidates competing in the FCs (or their respective agents), if they so wish, will be allowed to accompany the Deputy PRO(s)/Assistant PRO(s) in the delivery of the ballot boxes from the polling station to the central counting station under police escort. Where there are more than 2 persons with such intention

remaining at the polling station, the PRO will draw lots to determine which 2 candidates or their respective agents will participate in the delivery. Other FC candidates and their agents are allowed to remain in the polling station only until they see that the police escort for the delivery is available. Thereafter, all of them shall leave the polling station. They may enter the counting station to observe the count of the GC votes in the public area.

[Amended in July 2008 and June 2016]

7.35 Generally speaking, a polling agent may observe all proceedings in the polling station for which he/she has been appointed and record his/her observations but shall not do anything that may interfere with the conduct of the poll. A polling agent **may**:

- (a) observe the locking and sealing of empty ballot boxes before the poll commences and the locking and sealing of the ballot boxes during or at the close of the poll; *[Amended in June 2012]*

NOTE :

A polling agent who signs the sealing certificate of a ballot box as witness is required to write his/her name in block letters beneath his/her signature for easy identification. Candidates are advised to keep a list of their own polling agents to facilitate checking when the sealing certificate is broken at the counting station.

- (b) leave the polling station at any time during the poll in which case his/her place may be taken by the relevant candidate, election agent or another polling agent (representing the same

candidate/list of candidates) appointed to attend at the polling station [see para. 7.31 above];

- (c) subject to para. 7.36(b) below, observe the issue of ballot papers to electors/ARs and the crossing out of entries from the copy of the register of electors, subject to the condition that they cannot interfere with the work of the polling staff;
- (d) where there is reasonable ground for questioning the bona fides of an elector/AR, ask the PRO to put the following prescribed questions (subject to necessary modifications having regard to whether the ballot paper applied for is a GC ballot paper or an FC ballot paper) to that person at the time of his/her application for a ballot paper (but not afterwards):
 - (i) Are you the person registered in the final register now in effect for this GC and/or FC (as appropriate), as follows (reads the whole of the relevant entry in the register)?
[Amended in October 2007]
 - (ii) Have you already voted for this or any other GC and/or FC (as appropriate) in this election?

NOTE :

The person will not be issued with any ballot paper unless he/she has answered the questions to the satisfaction of the PRO.

[S 51(3), (4) and (5) of the EAC (EP) (LC) Reg]

- (e) where there is reasonable cause to believe that a person who has applied for a ballot paper has engaged in corrupt conduct by

impersonation, inform the PRO for appropriate action before that person leaves the polling station. This may possibly lead to the arrest of the person. The polling agent must however undertake in writing to give evidence to substantiate the allegation in a court of law [s 52(1) of the EAC (EP) (LC) Reg]. *[Amended in June 2012]*

[Amended in October 2007, January 2010, June 2012 and June 2016]

7.36 Inside a polling station, a polling agent **must not**:

- (a) interfere with or attempt to influence any elector/AR;
- (b) speak to or communicate with any elector/AR, or interfere with or attempt to interfere with any ballot boxes, ballot papers, the marked copy of the register of electors or other relevant election materials. In this regard, a polling agent should station within the designated area demarcated by red adhesive tape, and must not enter, or move close to, the restricted zone delineated with yellow tapes about 1 metre, or 2 metres if the configuration allows, around the voting compartments. Moreover, it is most improper for a polling agent to ask an elector/AR about his/her identity card number, let alone check an elector/AR's identity card;
- (c) attempt to obtain information, or disclose any knowledge acquired, concerning the vote of any elector/AR. A polling agent should read and observe carefully the provisions governing the secrecy of voting issued with the form of Declaration of Secrecy;
- (d) exhibit or leave or distribute any campaign material;

- (e) display or wear any propaganda material, e.g. any badge, emblem, clothing or head-dress which:
 - (i) may promote or prejudice the election of a candidate or candidates at the election; or
 - (ii) makes direct reference to a body any member of which is standing as a candidate in the election or to a prescribed body the registered name or registered emblem of which has been printed on any ballot paper for the election; or
[Amended in October 2007]
- (f) use a mobile telephone or any telephone or paging machine or any other form of electronic communication device.

[Ss 45 and 96 of the EAC (EP) (LC) Reg] *[Amended in October 2007 and June 2016]*

7.37 A polling agent must not misconduct himself/herself in or in the vicinity of a polling station or fail to obey any lawful order of the RO or the PRO; otherwise he/she commits an offence and will be liable to a fine and to imprisonment and may be ordered by such officer to leave the area. If he/she fails to leave immediately, he/she may be removed by:

- (a) a police officer if the polling station is not a dedicated polling station; or
- (b) an officer of the CSD or any law enforcement agency if the polling station is a dedicated polling station; or
- (c) any other person authorised in writing by the RO or the PRO to

remove him/her.

The person so removed may not re-enter the polling station during that day except with the permission of the RO or the PRO [s 46(2), (3) and (4) of the EAC (EP) (LC) Reg]. *[Amended in January 2010]*

Other Useful Information for Polling Agents

7.38 Polling staff, candidates, their election agents and polling agents will be required to wear an identification device issued by the RO or the PRO for identification. If in doubt, a polling agent may enquire with the PRO as to the identities of the persons inside the polling station. No attempt, however, should be made to obtain information as to the identity of any elector/AR who is about to vote or has voted [s 96(8) of the EAC (EP) (LC) Reg]. *[Amended in June 2016]*

7.39 Electors with a disability may be permitted to vote in a special polling station designated for that purpose. Candidates or their agents can make inquiries with the RO for information.

7.40 Only the PRO, the Deputy PRO or an Assistant PRO may, in the presence of one of the polling officers as a witness, help an elector to mark a ballot paper if he/she claims that he/she is unable to read or is incapacitated from casting his/her vote due to visual impairment or other physical disabilities [s 59(1) and (2) of the EAC (EP) (LC) Reg]. The responsible officer should inform the candidates or their agents who are present when such a request for assistance is received. A candidate or his/her polling agent in the polling station may suggest the PRO, the Deputy PRO or an Assistant PRO to choose a particular Polling Officer who is not working at the issuing counter as the witness, but the final decision as to which Polling Officer should be the witness remains with the PRO, Deputy PRO or Assistant PRO. An elector's relative, friend or any other person is in no circumstances allowed to accompany the

elector in the course of voting. *[Amended in June 2012]*

7.41 In each polling station designated for an election in respect of a GC or a FC, a number of **braille templates** are made available for the use of electors with visual impairment, if they so choose, to facilitate them to mark their vote on the ballot paper [s 59(3) of the EAC (EP) (LC) Reg]. The basic features of the template are as follows:

- (a) the template for each constituency is of the same width and length as the ballot paper;
- (b) the template contains numbers in braille starting with the first numeral in a sequence assigned to the candidates/list of candidates of the constituency from the top downwards and on the right hand side against each of the number is a round hole;
- (c) the **top left hand corner** of the ballot paper and the template is cut so as to guide the elector to place the template on top of the face of the ballot paper in the proper direction; and
- (d) when the template is placed properly over the ballot paper, each braille number corresponds with the candidate number or the number of a list of candidates in the constituency; and each of the holes on the template corresponds with the circle on the ballot paper against the candidate/list number. The number of holes equals the number of candidates/lists in the constituency.

In the case of an election in respect of a GC/DC (second) FC which adopts the “list system of proportional representation” or an ordinary FC which adopts “first past the post voting system”, an elector with visual impairment should apply the chop with a “✓” sign so provided in the circle through the hole on the template against the candidate/list number. In the case of an election for one

of the 4 SFCs which adopts the “preferential elimination system”, the elector with visual impairment should mark numbers starting from 1 on the ballot paper through the hole against the candidate numbers of his/her choice, in descending order of preference. Whenever it is necessary, the polling staff will help the elector with visual impairment to identify the different ballot papers before the elector proceeds to mark his/her choice. *[Amended in June 2012 and June 2016]*

7.42 No person may canvass, display or wear any election propaganda material relating to any candidate/list of candidates or the election within a polling station. Candidates and their agents should not bring electioneering materials into the polling station or leave them there, and should remove any promotional badges, emblems, clothing and head-dress before entering. A person must not use a sound amplifying system or device for any purpose within the NCZ; nor should he/she use such system or device or conduct any activities (e.g. lion dance), for canvassing, so that the sound emitted by it can be heard within the NCZ. [Ss 40(16) and 41(1) of the EAC (EP) (LC) Reg] However, an officer of the CSD may use a sound amplifying system or device in the NCZ of a dedicated polling station situated in a prison for the performance of his/her duties on the polling day [ss 40(19) and 41 (1A) of the EAC (EP) (LC) Reg]. Also, a person must not stay or loiter in the NSZ without the express permission of the PRO [s 41(1)(d) of the EAC (EP) (LC) Reg]. Any person who undertakes photographing, filming and video or audio recording within a polling station without the express permission of the PRO, the RO for the constituency, or a member of the EAC, commits an offence and will be liable to a fine at level 2 (\$5,000) and to imprisonment for 6 months [s 45(2) and (7) of the EAC (EP) (LC) Reg]. Normally such permission is only granted to government photographers for publicity purposes. Polling agents should also read Parts I to VI of Chapter 5 on all matters relating to polling and in particular, paras. 5.43 to 5.46 for activities that are prohibited, and the consequences of conducting such activities, in a polling station. *[Amended in October 2007, June 2012 and June 2016]*

7.43 If a candidate or his/her election or polling agent has any complaint about whatever happens inside a polling station, he/she should follow the procedures laid down in Chapter 20 on Complaints Procedure of these Guidelines.

PART VIII : COUNTING AGENTS

Appointment

7.44 A candidate/list of candidates may appoint not more than such number of counting agents as will be specified by the EAC to attend at the count at a counting station and to observe the sorting of ballot papers received from dedicated polling stations at a ballot paper sorting station [ss 2(6) and 66(1) and (2) of the EAC (EP) (LC) Reg]. The same persons may, but need not, be appointed also as polling agents. *[Amended in January 2010, June 2012 and June 2016]*

7.45 The notice of appointment must be in writing, in the specified form signed by the candidate (in the case of a list of candidates, the notice of appointment must be signed jointly by all the candidates on the list) and delivered by hand, by post, by electronic mail or by facsimile transmission to the RO at least **7 days** before the polling day [ss 2(6), 66(3), (5), (5A) and (7) of the EAC (EP) (LC) Reg]. Where a candidate wishes to appoint a counting agent after the above deadline, the notice of the appointment must be delivered by the candidate (or in the case of a candidate list, any one of the candidates on the list) or the election agent **in person** to the PRO for the relevant counting station (or the RO in the central counting station) on the polling day during the period from the commencement of the poll to the conclusion of the count or the completion of the sorting of ballot paper as the case may be [ss 2(6) and 66(6) of the EAC (EP) (LC) Reg]. The appointment is only effective when the

notice of such appointment is received by the RO or the PRO, as the case may be [ss 2(6) and 66(8) of the EAC (EP) (LC) Reg]. *[Amended in January 2010, June 2012 and June 2016]*

Revocation

7.46 The appointment of a counting agent may be revoked by the candidate (or in the case of a list of candidates, all the candidates on the list) at any time. The candidate (or in the case of a list of candidates, any one of the candidates on the list) must also give notice of revocation in writing in the specified form and deliver the signed notice by hand, by post, by electronic mail or by facsimile transmission to the RO (other than on the polling day) [ss 2(6) and 66(9), (10) and (10A) of the EAC (EP) (LC) Reg]. In the case of a list of candidates, a notice of revocation must be signed by all the candidates on the list [s 66(7) of the EAC (EP) (LC) Reg]. If the notice of revocation is given on the polling day, such notice must be delivered by the candidate (or in the case of a list of candidates, any one of the candidates on the list) or his/her election agent **in person** to the PRO for the relevant counting station (or the RO in the central counting station) [ss 2(6) and 66(11) of the EAC (EP) (LC) Reg]. A revocation of an appointment of a counting agent is not effective until notice thereof is received by the RO or the PRO, as the case may be [ss 2(6) and 66(12) of the EAC (EP) (LC) Reg]. *[Amended in January 2010, June 2012 and June 2016]*

Role of Counting Agents

- 7.47 Counting agents are appointed to attend at:
- (a) the counting stations to observe the breaking of the seals on the ballot boxes, the sorting, separation and counting of ballot papers and the counting of votes recorded on the valid ballot papers; or

- (b) the ballot paper sorting stations to observe the breaking of the seals on the ballot boxes received from dedicated polling stations and the sorting of the GC ballot papers cast at the dedicated polling station.

This arrangement ensures the transparency of the counting and sorting process and is conducive to openness and fairness. [See Parts VII and VIII of Chapter 5.] *[Amended in January 2010]*

Provisions which the Counting Agents should be aware of

7.48 Before the counting of votes or sorting of ballot papers commences, every person authorised to be present at a counting station or a ballot paper sorting station, other than police officers and members of the CAS on duty, must make a Declaration of Secrecy on a specified form and observe the provisions governing the secrecy of voting [s 95(2) of the EAC (EP) (LC) Reg]. This is to make sure that, subject to penalty of making a false declaration, all persons inside a counting station or a ballot paper sorting station will observe the secrecy of the vote of the elector and, in particular, not to divulge which elector has voted for which candidate and/or list of candidates. Members of the public present within the area designated by the PRO or the CRO or the RO will not be required to make a Declaration of Secrecy. *[Amended in January 2010 and June 2012]*

7.49 On attending the counting station or the ballot paper sorting station, a counting agent shall report to the relevant RO or PRO, as appropriate and produce his/her identity card and the Declaration of Secrecy completed by him/her for inspection [ss 2(6) and 68(4) of the EAC (EP) (LC) Reg]. *[Amended in June 2012 and June 2016]*

7.50 Counting agents are entitled to be present throughout the count to observe the relevant counting proceedings. They will be allowed by the RO

or the PRO to stay close to, and round the counting tables to monitor the count. Nonetheless, they must not handle any ballot papers. A counting agent **may**:

- (a) observe the breaking of the seals on the ballot boxes and the opening of the ballot boxes for the relevant constituency by the RO/AROs/PRO; *[Amended in June 2012]*
- (b) inspect any papers other than ballot papers taken from the ballot boxes before they are disposed of;
- (c) observe the conduct of the count by counting officers including how ballot papers relating to a constituency are separated from those relating to other constituencies and how individual votes are counted;
- (d) observe the determination of questionable ballot papers by the PRO or the RO and make representations on behalf of the candidate/list of candidates concerned [s 81(7) of EAC (EP) (LC) Reg]; and
- (e) observe, where he/she wishes, the packing of ballot papers by the counting officers and the RO or the PRO, as the case may be, at the conclusion of the count.

[Amended in January 2010, June 2012 and June 2016]

7.51 A counting agent in a ballot paper sorting station **may**:

- (a) observe the opening of the GC ballot boxes received from dedicated polling stations;

- (b) inspect any papers other than the ballot papers taken from the ballot boxes before they are disposed of;
- (c) observe the counting of the GC ballot papers in each ballot box;
- (d) observe the sorting of the aforesaid GC ballot papers according to each GC; and
- (e) observe the sealing of the receptacles containing the sorted GC ballot papers before they are delivered to the PRO of the respective main counting stations of the relevant GCs.

[Added in January 2010]

7.52 A counting agent **must not**:

- (a) handle, separate or arrange ballot papers; and
- (b) misconduct in or in the vicinity of a counting station or a ballot paper sorting station, or fail to obey any lawful order of the CRO/RO/PRO, as the case may be, otherwise he/she commits an offence and will be liable to a fine at level 2 (\$5,000) and to imprisonment for 3 months and may be ordered by the CRO/RO/PRO to leave the area. If he/she fails to leave immediately, he/she may be removed by a police officer or by any other person authorised in writing by the CRO/RO/PRO to remove him/her. The person so removed may not re-enter the counting station or the ballot paper sorting station during that day except with the permission of the CRO/RO/PRO, as the case may be [ss 2(6) and 69 of the EAC (EP) (LC) Reg].

[Amended in January 2010]

7.53 Counting agents should read Part VII and Part VIII of Chapter 5 on all matters relating to sorting of ballot papers and counting of votes and in particular, paras. 5.53 to 5.57 and paras. 5.62 to 5.68 for activities that are prohibited, and the consequences of conducting such activities, within the ballot paper sorting station and counting station. *[Amended in October 2007 and January 2010]*

CHAPTER 8

ELECTION ADVERTISEMENTS

PART I : WHAT CONSTITUTES AN ELECTION ADVERTISEMENT

8.1 An election advertisement (“EA”), in relation to the LegCo election, means:

- (a) a publicly exhibited notice, leaflet, circular, bill, booklet, placard or poster; or
- (b) a notice, leaflet, circular, bill, booklet, placard or poster delivered by hand or electronic transmission; or
- (c) a public announcement made by radio or television or by video or cinematographic film; or
- (d) any other form of publication,

published for the purpose of promoting or prejudicing the election of a candidate or candidates at the election [s 2 of the ECICO and s 2 of the EAC (EP) (LC) Reg]. *[Amended in June 2012]*

IMPORTANT:

“Candidate” includes a person who has publicly declared an intention to stand for an election at any time before the end of the nomination period for the election, whether or not he/she has submitted a nomination form [s 2 of the ECICO and s 2(2) of the

EAC (EP) (LC) Reg]. The reference of “candidate” in this chapter includes a list of candidates in a GC/DC (second) FC to which the list system of proportional representation applies.

“Publish” means print, display, exhibit, distribute, post up, publicly announce or make publicly known by any other means, and includes continue to publish [s 104(1) of the EAC (EP) (LC) Reg]. *[Added in June 2012]*

Any person who authorises the publication of an EA is taken to have published the EA [s 104(2) of the EAC (EP) (LC) Reg]. *[Added in June 2012]*

8.2 **An EA** includes the following if it is published for the purpose of promoting or prejudicing the election of any candidate or candidates in an election:

- (a) any address, notice, bill, placard, poster, board, banner, roll-up banner, flag, standard, colour, sign, message, sound, image or picture and any article, thing or material; *[Amended in July 2008]*
- (b) audio/video cassette tapes, discs, diskettes, electronic messages, websites, facsimile transmissions, balloons, badges, emblems, carrier bags, head-dress and clothing; or *[Amended in October 2007]*
- (c) any thing or material published by any person or any organisation, including political organisation, professional or trade organisation, owners’ corporation, mutual aid committee (“MAC”), tenants’ association, owners’ committee, etc. (irrespective of whether or not the candidate concerned is its office-bearer or member)

showing his/her or its support for any candidate/list of candidates or advertising the platform or services of such an organisation with reference to a candidate or candidates/list(s) of candidates by name or photograph or in any other form or manner. *[Amended in June 2012]*

8.3 As stated in para. 8.1 above, EA is defined to include any messages published publicly for the purpose of promoting or prejudicing the election of a candidate or candidates at an election under s 2 of the ECICO. Any materials published by any person or organisation during or before the election period to appeal directly or indirectly to electors to vote or not to vote for certain candidates or candidates belonging to or affiliated with certain organisations, irrespective of the form of publication and whether they contain any names or photographs of candidates, may also be regarded as EAs depending on all the circumstances at the time since when read in their whole context, the materials concerned may be capable of being reasonably understood by an elector as referring to certain identified candidate(s) or group(s) of candidates. The expenses incurred for the publication of such materials will be regarded as election expenses incurred by or on behalf of the candidate(s). If expenses are involved in the publication of the EA and the publisher is neither a candidate nor a candidate's election expense agent, the publisher may engage in illegal conduct under the ECICO. If a candidate instructs that person or organisation to publish the EAs, the candidate will also violate the law if such expenses are not accounted for as election expenses. *[Added in June 2016]*

8.4 The statutory definition of EA is very wide and encompasses anything published publicly by any means, including a message published through internet platforms (e.g. websites, social media, communication networks, etc.) for promoting the election of a candidate/list of candidates or prejudicing the election of other candidates/lists of candidates. However, if web surfers merely share or forward different candidates' election campaigns

through internet platforms for expression of views and do not intend to promote or prejudice the elections of any candidates, such sharing or forwarding will not normally be construed as publishing EAs. However, if the web surfers are instructed by the candidate or candidates on the list or his/her/their election helpers to share or forward the election campaigns through internet platforms with the intention to promote or prejudice the election of a candidate or candidates at the election, such act will be regarded as publication of the candidate's or candidates' EAs and any costs incurred will have to be included in the election expenses of the candidate/list of candidates. The candidate(s) should also observe fully the requirements relating to publication of EAs as set out in para. 8.50 below. *[Added in June 2016]*

8.5 In addition, any publicity materials containing the name or photograph of a candidate/list of candidates issued or displayed during the election period (i.e. the period beginning on the first day of the nomination period for the election and ending on the day on which the polling for the election ends, or on the day on which a declaration is made in accordance with ss 42C or 46 of the LCO or s 22C of the EAC (EP) (LC) Reg) may also be regarded as EAs. Even though the content of the publicity materials is not, on the face of it, election-related, the candidates may still receive the promotional effect depending on circumstances. *[Amended in June 2016]*

8.6 Under s 104 of the EAC (EP) (LC) Reg, the definition of "publish" includes "continue to publish". In this regard, for the sake of prudence, any person who intends to stand as a candidate at the election, including but not limited to an incumbent member of the LegCo or a DC (who should also comply with the terms and conditions under the Lands Department's Management Scheme for the Display of Roadside Non-commercial Publicity Materials, if his/her publicity materials are being displayed under the said Scheme), should ensure that all publicity materials

published by him/her in the constituency concerned¹³ prior to the election period, especially posters or banners bearing his/her name or photograph displayed at a public place or at the common parts of a building, are removed before he/she has been nominated as a candidate or has publicly declared an intention to stand as a candidate at the election. Otherwise, any unremoved publicity material **may** be regarded as an EA in accordance with the foregoing principles. *[Added in June 2016]*

8.7 Under s 104(4) of the EAC (EP) (LC) Reg, a document published by a candidate **during** an election period that gives details of the work done by the candidate in the capacity of:

- (a) the CE; or
- (b) a member of the LegCo; or
- (c) a member of a DC; or
- (d) a member of the Heung Yee Kuk; or
- (e) the Chairman or Vice-Chairman or a member of the Executive Committee of a Rural Committee within the meaning of s 3(3)(a) of the Heung Yee Kuk Ordinance (Cap 1097); or
- (f) a Rural Representative (“RR”),

is also regarded as an EA. *[Amended in June 2012 and June 2016]*

8.8 For the avoidance of doubt, if a person who has publicly declared his/her intention to stand as a candidate at an election **before** the election

¹³ In the case of an election for the FC, the constituency concerned would be construed in the context of the provision to mean the whole territory of Hong Kong.

period, publishes a document as mentioned in para. 8.7 above, the document will also be regarded as an EA if it is published for the purpose of promoting or prejudicing the election of a candidate or candidates at the election. It is important to note that a document referred to in this paragraph and para. 8.7 above must comply with all the requirements for an EA and the expenditure so incurred be accounted for as election expenses. *[Amended in October 2007, June 2012 and June 2016]*

8.9 If a person publishes a document before he/she submits his/her nomination form or publicly declares his/her intention to stand as a candidate that gives details of his/her work done by him/her in his/her capacity as set out in para. 8.7 above without promoting or prejudicing the election of a candidate or candidates at the election, the document will not be construed as an EA. On such basis, the expenditure incurred in the publication of such a document would not be counted as election expenses. *[Amended in June 2012]*

8.10 A candidate in an election may publish EAs in accordance with all the relevant laws and regulations and these guidelines.

Election Advertisements Prejudicing the Election of a Candidate

8.11 There are occasions that candidates or a third party may publish EAs for the purpose of prejudicing the election of a candidate at the election. The concept of “promoting” and “prejudicing” the election of someone can be relative. To publish a document which is designed to persuade electors not to vote for one candidate would have the effect of improving the chances of success of other candidate(s) and could therefore be said to promote the latter’s election. For example:

- (a) If candidate A criticises candidate B in his/her own EAs with a view to prejudicing B’s candidature at the election, candidate A has to include the expenditure incurred in his/her election

expenses.

- (b) If a third party criticises candidate B in an EA and the EA has the effect of indicating support for candidate A, the third party must obtain candidate A's prior written consent for incurring the production expenses before he/she produces that EA, and the expenditure incurred will have to be included in candidate A's election expenses.
- (c) If the third party publishes an EA as described in (b) above without the prior written consent of candidate A, that third party will be breaching s 23 of the ECICO as only a candidate or a person who has been duly authorised by a candidate as his/her election expense agent may incur election expenses. It would only be fair to candidate A that the third party needs to obtain candidate A's written consent before publishing such EA. It would also prevent candidate A from circumventing the law by asking the third party to publish materials prejudicing candidate B without having to account for the expenses of those materials.

[Amended in June 2016]

8.12 Materials published by any person, including a candidate, for the purpose of prejudicing a candidate or candidates are treated as EAs, if reference could be made from the materials to identify the candidate(s) being prejudiced.

8.13 The **election expenses** allowed by law to be incurred by a candidate include the expenses he/she incurs for the preparation and publication of EAs, and he/she should therefore be careful in planning how much he/she should spend in this area. [For the definition of election expenses, see s 2 of the ECICO.]

8.14 Subject to the maximum amount that can be incurred by a candidate for election expenses [s 24 of the ECICO], there is no restriction as to the quantity of EAs employed by him/her. The maximum amounts allowed for the elections of GCs and FCs are specified in the Maximum Amount of Election Expenses (Legislative Council Election) Regulation. [See para. 16.10 of Chapter 16.]

8.15 A candidate must ensure the correctness and accuracy of all factual statements in his/her EAs. In particular, a candidate is reminded to comply with the requirements for obtaining prior written consent of support from other persons or organisations, which are summarised in Chapter 18. [For criminal sanctions, see ss 25, 26 and 27 of the ECICO.] *[Amended in June 2016]*

PART II : PERIOD AND AREA OF DISPLAY

8.16 Subject to the necessary **written permission or authorisation**, a candidate may display EAs on government or private land and property [s 104A(1) of the Public Health and Municipal Services Ordinance (Cap 132) (“PHMSO”) and s 4 of the Land (Miscellaneous Provisions) Ordinance (Cap 28)].

8.17 Display spots are classified into two types:

- (a) **designated spots** which are spots on government land/property and sometimes even at the premises owned or occupied privately that have been made available to the Government for allocation to candidates of the 5 GCs and the 29 FCs; and
- (b) **private spots** which are spots on private land/property in respect of which written permission or authorisation for display has been

obtained from the owner or occupier concerned by the candidate himself/herself.

Government or Private Land/Property - Designated Spots

8.18 Allocation of designated spots for the use of **contested** GC/DC (second) FC candidates to display their EAs will be made by the RO for the relevant GC/DC (second) FC. Some of the government land/property have been allocated to some public authorities, such as the Housing Authority, and are under their respective control. The RO for the relevant GC/DC (second) FC may designate spots on such allocated land/property in coordination with the said authorities. For GC/DC (second) FC, the designated spots will be allocated to candidates by reference to and on the basis of lists. **Each list of candidates competing in the same constituency will be allocated the same number of designated spots.** *[Amended in June 2012]*

8.19 Designated spots for traditional FCs will be allocated by the relevant ROs in the similar way. There may be certain places on government or private land/property where candidates of the traditional FCs may wish to display their EAs, because those places are frequented by members of their electorate. Where considered appropriate, the respective ROs will identify and designate suitable display spots in these places for allocation to candidates. *[Amended in June 2012]*

8.20 Prospective candidates as well as political organisations are welcome to suggest locations of display in which they are interested. The ROs concerned will take into consideration such suggestions in drawing up the list of “**designated spots**”, but with absolute discretion to decide whether to adopt the suggestions.

NOTE:

Suggestions under para. 8.20 should reach the CEO not later than **8 weeks before the polling day.** *[Amended in July 2008 and June 2012]*

Other Land/Property - Private Spots

8.21 Candidates who wish to display their EAs on land/property other than government land/property and other than the designated spots must **obtain the prior written permission or authorisation** of the owner or occupier [s 104A(1) of the PHMSO]. The obtaining of written permission or authorisation from the private owner or occupier is a matter for private arrangement between the candidate and the owner or occupier, and they are therefore called “**private spots**”. A copy of all the permissions or authorisations obtained by a candidate himself/herself must be provided by him/her for public inspection in the manner as set out in para. 8.50 below. [Please also see para. 8.27 below.] Any consideration, fee or money incurred or agreed to be paid by or on behalf of the candidate to the owner or occupier for display of his/her EAs forms part of his/her election expenses. If the private spot secured for displaying the EA is normally used for commercial purpose, the actual rent charged or the usual rent or market rent that would normally be charged should be counted as the election expenses of the candidate concerned, irrespective of whether it is owned by the candidate or whether the owner of it allows the candidate to use it free of charge (in which case it would be a donation of the rent). Where a space provided by a particular private owner or occupier for a candidate to display EAs is not used for commercial advertising, but similar space belonging to other owners or occupiers is available for commercial advertising, the market value of the space should also be accounted for. The provision of this kind of rent-free space should be regarded as election donation and counted as election expenses. Such a provision is to ensure that the candidate concerned will not have unfair

advantage over the others who do not have access to such facilities. For details on how the estimated value should be assessed, please refer to para. 16.24 of Chapter 16. If a space is not the type normally used by any private owners or occupiers for commercial advertising, there is no need for the candidate to account for its value. *[Amended in June 2016]*

8.22 For the display of EAs at the common parts of private premises (those parts to which exclusive rights of use or occupation do not belong to a particular owner or tenant), the EAC appeals to owners and occupiers of private premises concerned to give all candidates/lists of candidates competing in the same constituency **fair and equal treatment**. [For details, please see Chapter 9.] *[Amended in June 2012 and June 2016]*

8.23 Candidates should note that public corporations (e.g. the MTR Corporation Limited) may have their own rules for display of EAs in properties under their management. *[Amended in June 2016]*

Allocation of Designated Spots

8.24 In principle, available designated spots will be allocated among the different constituencies in the following manner:

<u>Constituency</u>	<u>Percentage of total</u>
GCs	50
DC (second) FC	30-40
other FCs	10-20

No designated spot will be provided to a candidate who is returned uncontested. *[Amended in June 2012]*

8.25 The RO for each constituency will allocate the designated spots to candidates of the constituency either in accordance with the mutual consent

of the candidates or by the drawing of lots after the end of the nomination period, when the number of candidates/lists of candidates contesting in the constituency will have been ascertained. **No display of EAs will be allowed on any designated spots before the allocation.** [Also see the requirements in para. 8.31 and Part VI below.] EAs displayed by the candidates on government land/property other than designated spots are unauthorised and will be removed, save those EAs displayed in connection with electioneering activities conducted on government land/property with approval by the authorities concerned. A candidate/list of candidates will be provided with a list of the designated spots allocated to him/her/it, together with a set of standardised map or maps to help identify the locations. *[Amended in July 2008 and June 2012]*

8.26 Candidates/lists of candidates using the designated spots are required to read and comply with all the requirements and conditions stipulated in the “Conditions for Display of EAs at Designated Spots”, which will be provided to each candidate in the candidate’s folder and uploaded onto the EAC’s webpage. To safeguard the safety of road users, candidates should ensure that EAs on display must not distract motorists or interfere with the sight lines of motorists and pedestrians, or obscure any traffic sign or traffic light signal. *[Amended in June 2012]*

Written Permission or Authorisation

8.27 The RO will obtain prior approval from the relevant authorities under s 104A(1) of the PHMSO and s 4 of the Land (Miscellaneous Provisions) Ordinance for candidates to display their EAs at designated spots. Immediately after the allocation of designated spots is made, a copy of the necessary written permission or authorisation under the relevant legislation will be provided to the candidates by the RO of the constituency concerned [see Part III below]. For any display on private premises, written permission or authorisation of the private owner or occupier will have to be obtained by the

candidates themselves [s 104A(1) of the PHMSO]. A person displaying an EA without the necessary written permission or authorisation commits an offence and will be liable to a fine of \$10,000 and, where the offence is a continuing offence, by an additional daily penalty of \$300 for each day during which it is proved to the satisfaction of the court that the offence has continued [s 104A(2) of the PHMSO]. A copy of all the permissions or authorisations obtained by a candidate himself/herself, as opposed to those provided to him/her by the RO, must be provided by him/her for public inspection in the manner as set out in para. 8.50 below. All candidates are also reminded that if carrying out of building works (including erection of signboards) at private premises is involved for display of the EA, the relevant provisions of the Buildings Ordinance (Cap 123) (“BO”) and the subsidiary regulations should be complied with. In this regard, the candidates are strongly advised to consult building professionals, registered contractors and, where necessary, authorised persons on the compliance with the BO, and to make submission in accordance with the simplified requirements under the Minor Works Control System or formal application for approval and consent from the Buildings Department as appropriate before the carrying out of such works. *[Amended in July 2008, June 2012 and June 2016]*

No Canvassing Zone

8.28 No EA may be displayed within the boundaries of a polling station (including the outer walls of the premises) or within any **NCZ** [see Chapter 14], except for static display of EAs mounted at designated spots approved by the RO. Where there are private premises situated within the NCZ, the ROs should issue a notice in advance to all the candidates in the constituencies concerned asking them to remove all of their EAs, if any, posted up at the private premises within the NCZ which can be seen by electors on their way to the polling stations on the polling day. If the candidates fail to remove the EAs as requested by the ROs, the ROs may issue a warning to them

to remove the offending EAs immediately. If the candidate/list of candidates fails to do so, the EAC may issue a censure or reprimand. The RO for the constituency for which a candidate/list of candidates stands will provide each candidate/list of candidates with 1 set of sketch maps or plans showing the boundaries of all polling stations in respect of the relevant constituency and all NCZs outside those polling stations. *[Amended in June 2012]*

PART III : ALLOCATION OF DESIGNATED SPOTS

8.29 A candidate/list of candidates of a constituency can obtain the following information from the RO for that constituency at the time of submitting the nomination form:

- (a) the general locations of the designated spots, which may include unleased government land and premises managed by the Housing Department and the Hong Kong Housing Society, and occasionally private premises (if any) available for allocation to the candidates for a particular constituency. The size and number of spots for allocation will be finalised by the RO, taking into account the number of candidates in the constituency, **after** the end of the nomination period. In order to allow all contested candidates to display their EAs at all locations, particularly popular ones, the size of each spot may vary from location to location; and
- (b) the date and time for conducting the allocation of designated spots, which would normally be held within 3 working days after the end of the nomination period. The RO will invite representatives from the relevant authorities relating to government land/property, save those who have already given a blanket approval, to be present to give the necessary written

authorisation for the spots allocated.

[Amended in June 2012]

8.30 The RO for the constituency will need to know the exact number of candidates/lists of candidates who wish to display EAs at designated spots within a particular GC area, so that they can finalise the number of designated spots and their size for allocation. Therefore, candidates/lists of candidates who wish to display EAs at designated spots **must register their interest in writing by filing a completed form to the relevant RO within the nomination period. Only candidates of contested constituencies will be allocated with designated spots.** *[Amended in October 2007 and June 2012]*

8.31 The principle of allocation of designated spots is that candidates/lists of candidates contesting in the same constituency should each be allocated the same number of designated spots and an equal area of space for mounting EAs. Designated spots are allocated by agreement of the representatives of all the contested candidates/lists of candidates of a constituency or by the drawing of lots. After allocation of the spots and the necessary authorisations have been obtained from the relevant authorities [s 104A(1) of the PHMSO and s 4 of the Land (Miscellaneous Provisions) Ordinance] and after complying with the requirements set out under Part VI, the candidate/list of candidates may display EAs at such spots allocated to him/her/it. *[Amended in June 2012 and June 2016]*

8.32 A copy of all the permissions or authorisations obtained by a candidate himself/herself, as opposed to those provided to him/her by the RO, must be provided by him/her in the manner as set out in para. 8.50 below [s 105(2) and (3) of the EAC (EP) (LC) Reg]. *[Amended in July 2008 and June 2012]*

8.33 Subject to para. 8.35, designated spots allocated are not transferable. Nor are they exchangeable with other spots. Where a candidate of a particular constituency no longer wishes to use one or more designated spots allocated to him/her, he/she should inform the RO of that constituency in writing within 1 week after the allocation of those spots. At a contested election, upon request by any other candidate of the same constituency, the RO, if he/she considers appropriate, will re-allocate by agreement or by the drawing of lots the designated spots amongst all other candidates who are eligible to be allocated with designated spots of the same constituency. In such a case, paras. 8.31 and 8.32 above apply. *[Amended in July 2008 and June 2012]*

NOTE :

In some cases, designated spots allocated in the first round of allocation are left unused for various reasons. The RO may re-allocate such spots to the relevant candidates by mutual consent or the drawing of lots. Candidates may wish to plan accordingly their resources in respect of EAs.

8.34 Candidates/Lists of candidates of a GC will not in principle be allocated designated spots outside the constituencies in which they stand for election. If, for any reason, a candidate/list of candidates in a by-election for a GC wishes to be allocated designated spots outside his/her/their constituency, he/she/they should write to the CEO to state the reasons as soon as possible after his/her/their nomination form has been handed in. If such request is considered technically feasible and justified, the CEO will proceed to identify suitable designated spots for inclusion in an allocation exercise but the CEO has the final decision as to whether or not to accede to the request. *[Amended in June 2016]*

8.35 An EA advertising 2 or more candidates/lists of candidates of the same or different constituencies jointly is allowed to be displayed on the designated spots allocated to the candidates/lists of candidates. Nevertheless, it is important to ensure that, for each one of the joint candidates/lists of candidates, the total area of all the spaces actually occupied for advertising the candidate/list of candidates on his/her/their EAs, including the joint EAs, mounted at the designated spots (as measured by the dimension of EAs) does not exceed the total area of the designated spots allocated to each of the candidates/lists of candidates. A joint EA is also subject to the size restrictions specified in para. 8.39 below. Through joint advertisement, the candidates concerned promote themselves at the election, and so each of the candidates would benefit from the joint advertisement. The expenses incurred for the joint EAs will therefore have to be borne by the candidates concerned in equal or proportional shares as their respective election expenses, to be calculated by the proportion of the size of the portion advertising each. In this connection, it is important to note that only a candidate himself/herself or his/her election expense agent may incur election expenses on his/her behalf [s 23 of the ECICO]. In order to comply with the requirement stipulated in s 27 of the ECICO, the candidates concerned also have to seek prior written consent of support from each other before publishing the joint EA. [See also paras. 7.18 to 7.20 of Chapter 7 and para. 18.8 of Chapter 18.] *[Amended in October 2007, June 2012 and June 2016]*

PART IV : CONDITIONS AND LIMITATIONS ON DISPLAY

Name of the Constituency

8.36 To avoid possible confusion to electors, EAs of all candidates of the GCs and all the FCs must bear the name of the constituency for which the candidate concerned is standing. Similarly, in respect of joint EAs, the name of the constituency (be it GC or FC) should be stated clearly in relation to each

of the candidates advertised. Either the full name of the constituency or its abbreviated name (to be advised by the RO for the constituency) may be used, dependent on the choice of the candidate for the constituency. In the case of a breach for EAs displayed at designated spots, the approval for the use of the designated spots in question will be revoked. *[Amended in June 2016]*

8.37 Likewise, all candidates should make known to the electors the name of their respective constituencies when they conduct joint canvassing activities.

Re-use of Old Publicity Boards

8.38 A candidate may re-use old publicity boards used at a previous election. However, any information in relation to the previous election, e.g. the candidate number, name of constituency, party affiliation and names of persons who supported the candidate at that election, should be fully obliterated before any old publicity board is re-used. This would not only avoid confusion to electors but would also help the candidate to avoid laying himself/herself open to allegations of false claim of support of persons who might not have consented to support him/her at the current election. The cost incurred in refurbishing as well as the estimated value of the old publicity boards will be counted towards the candidate's election expenses. *[Amended in June 2012]*

Size

8.39 As a general rule, EAs displayed at designated spots should not exceed 1 metre high and 2.5 metres long. In the case of designated spots at roadside railings, the EAs must be **printed on one side only** and be displayed at the **designated side of the railings** with the side of the EAs carrying the promotional messages **facing the designated direction of the spots**. Before displaying EAs, candidates are reminded to ensure that the EAs must not

distract motorists or interfere with the sight lines of motorists and pedestrians, obscure any traffic sign or traffic light signal, or obstruct the circulation of pedestrians. [See also para. 8.26 above.] For the rules on display of joint advertisement, see para. 8.35 above. *[Amended in October 2007, July 2008, June 2012 and June 2016]*

Mounting and Installation

8.40 The mounting and display of EAs must not cause any risk to injuries or property. The EAs must be firmly and separately fastened. *[Amended in June 2012]*

8.41 Permanent fixing devices, such as nails or insoluble glue, should not be used.

8.42 Use “tie-on” posters (rather than “stick-on” posters or metallic wires) to facilitate subsequent removal. *[Amended in June 2012]*

8.43 Do not stick posters on painted or varnished surfaces as their subsequent removal will cause damage or leave irremovable marks.

8.44 Do not excavate or erect any structure on public pavements, e.g. nailing boards to the ground. *[Amended in June 2012]*

8.45 Owners or occupiers of a property including a government authority may specify the way in which EAs are to be displayed, and may require an indemnity against any claim or damage arising from the display of such materials.

Dismounting

8.46 All candidates should remove all their EAs displayed on

government land/property **within 10 days** following an election. Failure to do so may result in prosecution being brought against the offending candidate and such advertisements removed and seized by the relevant authority. Relevant authorities will issue demand notes for the removal costs to the candidates concerned within 21 days after the election results have been published in the Gazette (normally the Friday after the polling day). The **cost of removal** will be construed as **election expenses** and the candidates must include all these costs as election expenses in their election returns. *[Amended in October 2007, June 2012 and June 2016]*

PART V : APPLICATION FOR TEMPORARY OCCUPATION OF GOVERNMENT LAND AT PUBLIC PLACE FOR HOLDING ELECTIONEERING ACTIVITIES

8.47 For temporary occupation of government land including public street, pavement, footbridge, public escalator systems and pedestrian tunnel for holding electioneering activities (such as setting up of a manned street counter and displaying of EAs which may include banners, roll up banners and vertical flying poster or bunting), candidates/lists of candidates are required to submit applications with scheduled date, time, location/spot and brief description of the proposed set-up, to the relevant District Lands Office (“DLO”) of Lands Department for consideration. DLOs will only consider applications from validly nominated candidates/lists of candidates and applications from uncontested candidates/lists of candidates will not be considered. Approved occupation should not exceed 2 m² in area and 2 m in height. The respective DLO will consult the government departments concerned in considering the applications. *[Added in June 2016]*

8.48 The Lands Department will issue detailed guidelines for candidates/lists of candidates to apply for temporary occupation of government land at public place for holding electioneering activities during election period.

The deadlines for submission of applications will be specified in the guidelines. Applications should be submitted to the relevant DLO according to the designated deadlines. Applications for occupying government land on the polling day should be submitted to the relevant DLO by the subject deadline as specified in the guidelines. The DLO will arrange drawing of lots to determine the allocation if necessary. On the polling day, the approval will be deemed to have been revoked if and when the spot falls under the NCZ. *[Added in June 2016]*

8.49 The DLOs will not consider applications for holding electioneering activities on government land outside the designated periods. No fee is required for the application above. Display of EAs is not permitted if and when the street counter is not manned. *[Added in June 2016]*

PART VI : REQUIREMENTS RELATING TO PUBLICATION OF ELECTION ADVERTISEMENTS

Copies for Public Inspection

8.50 A candidate must make available a copy of each of his/her EAs, and the relevant information/documents (see **Appendix E**) including publication information, permission or consent in relation to the EAs for public inspection **within 1 working day (i.e. any day other than a general holiday or Saturday) after publication of the EAs** by the following means:

- (a) posting an electronic copy each of all his/her EAs and the relevant information/documents onto an open platform¹⁴ maintained by the CEO or a person authorised by the CEO (“Central Platform”) in accordance with the procedures set out in

¹⁴ Open platform means a platform operated through the Internet to which the public has access without having to go through an access control process put in place for that platform.

Appendix E;

- (b) posting an electronic copy each of all his/her EAs and the relevant information/documents onto an open platform maintained by the candidate or a person authorised by the candidate (“Candidate’s Platform”) and provide the **electronic address** of the platform to the CEO **at least 3 working days before publication of the first EA (For details, please see Appendix E);**
- (c) if it is technically impracticable to comply with (a) or (b) above for EAs published through an open platform on the internet (such as when messages are sent through social networking or communication websites on the Internet like Twitter, Facebook, blogs, etc. and the exchanges are of an interactive and spontaneous nature), posting a hyperlink of such open platform and the information/documents relevant to the EAs onto the Candidate’s Platform or the Central Platform in accordance with the procedures set out in **Appendix E;**
- (d) providing 2 hard copies each of the EAs (or 2 identical full colour photographs/printouts/photocopies of each EA which cannot be practically or conveniently produced in specie) and 1 hardcopy each of the relevant information/documents to the RO; or
- (e) providing 2 identical copies of a CD-ROM or DVD-ROM each containing the EAs and 1 hardcopy each of the relevant information/documents to the RO.

As an interim arrangement, in case the RO has yet to be appointed and the Central Platform has yet to be established, the candidates should deposit his/her EAs and the relevant information/documents with the CEO in the same manner

as stated in (d) or (e) above. [S 105(2) and (3) of the EAC (EP) (LC) Reg]
[Amended in June 2012 and June 2016]

Publication Details

8.51 A candidate should provide information related to the printing/publication of his/her EAs (i.e. the name and address of the printer, date of printing/publication and number of copies printed) when posting the EAs onto the Candidate's Platform or Central Platform or submit the information in a specified form to the RO **within 1 working day after publication of the EAs** (see **Appendix E**) [s 105(4) and (6) of the EAC (EP) (LC) Reg]. A candidate must ensure the accuracy of all the information provided. *[Amended in October 2007 and June 2012]*

8.52 Where the information uploaded onto the Candidate's Platform or Central Platform or provided to the RO as set out in para. 8.51 above contains a mistake, the candidate should post such corrective information onto the Candidate's Platform or Central Platform or submit the corrective information in a specified form to the RO for public inspection. All such corrective information must be posted onto the Candidate's Platform or Central Platform or deposited with the relevant RO **within 2 working days after the polling day, the latest**. The information will be used as one of the basis for checking the candidate's election return and for the removal of unauthorised or offending EAs. For the avoidance of doubt, any amendment to the content of an EA will be regarded as publication of a new EA for which the requirements stated in paras. 8.50 and 8.51 above should be complied with, except the addition of the number or the letter of the alphabet of each candidate/list of candidates allocated at the Candidates' Briefing onto a published EA, in which case a copy of the EA bearing such addition and the corrective information must be made available for public inspection in accordance with this paragraph. *[Amended in June 2012 and June 2016]*

8.53 All EAs published must be posted onto the Candidate's Platform or the Central Platform or deposited with the RO by the candidate for public inspection in the manner specified in this Part VI. *[Amended in June 2012]*

8.54 A candidate must not display his/her EAs other than at the places permitted or authorised. *[Amended in June 2012]*

8.55 Speeches orally delivered by a candidate during election meetings or ad hoc visits will not be treated as EAs, but the copies of the speech provided to the audience or media will be regarded as printed EAs. Therefore, the candidates concerned are required to comply with all the requirements in this Chapter as applicable to EAs in the distribution of the copies and for public inspection. *[Added in October 2007 and amended in June 2012]*

8.56 In the circumstances where candidates contesting different constituencies use identical copies of an EA, each candidate/list of candidates concerned should each post an electronic copy of the EA and the relevant information/documents onto his/her/their Candidate's Platform or the Central Platform or deposit 2 copies of the EA and 1 copy of the relevant information/documents with the RO(s) concerned. [S 105(2) and (3) of the EAC (EP) (LC) Reg] *[Amended in June 2012 and June 2016]*

8.57 Copies of the EAs and the relevant information/documents must be made available for public inspection till the end of the period for which copies of election returns are available for inspection under s 41 of the ECICO, i.e. the period ending with the 60th day before the first anniversary of the date of the deadline for lodging the relevant election return [s 41 of the ECICO and s 105(7) of the EAC (EP) (LC) Reg]. A candidate electing to comply with para. 8.50(b) above must ensure that the Candidate's Platform is maintained till the end of the aforesaid inspection period to facilitate public inspection of the EAs [s 105(2)(b) of the EAC (EP) (LC) Reg]. The CEO will also publicise

the Central Platform and the electronic address of the Candidate's Platform to facilitate public inspection of the EAs. For a candidate electing to comply with para. 8.50(d) or (e) above, the RO concerned will make available a copy of the EAs and the relevant information/documents for public inspection at the RO's office as soon as practicable after copies of such EAs and information/documents have been furnished till the end of the aforesaid inspection period [s 105(7) of the EAC (EP) (LC) Reg]. *[Amended in June 2012 and June 2016]*

PART VII: REQUIREMENTS RELATING TO PRINTED ELECTION MATERIALS

Printing Details

8.58 All printed EAs, with the exception of those printed in a registered local newspaper, should bear printing details in Chinese or English, which should state the name and address of the printer together with the date of printing and the number of copies printed. It applies to all materials reproduced by any method of multiplying copies (e.g. printing machines, duplicators or photocopiers). The following are some suggested formats:

- (a) Printed by ABC Printing Works,
XX XZY Street, HK
On (date) in (number) copies

or

- (b) Printed by own office machine
XX XZY Street, HK
On (date) in (number) copies

[S 105(4) and (6) of the EAC (EP) (LC) Reg] *[Amended in June 2012]*

Election Advertisements Placed in Print Media

8.59 Where an EA is placed in the print media and takes the form of a news report or any other form which does not clearly show that it is an EA, the words “**Election Advertisement**” or “**選舉廣告**” must be stated in the advertisement, to avoid misunderstanding by readers that it is not an EA.

Inadvertent Omission of Printing Details

8.60 A candidate who has inadvertently omitted the printing details from his/her printed EAs can make a statutory declaration giving the omitted details, and deposit such declaration with the relevant RO **not later than 7 days after** the publication of the offending EA [s 105(6) of the EAC (EP) (LC) Reg]. Having taken this remedial step, he/she will not be prosecuted for contravention of s 105(4) of the EAC (EP) (LC) Reg. The statutory declaration will be made available for public inspection by the relevant RO till the period for which copies of election returns are available for inspection under s 41 of the ECICO [s 105(7) of the EAC (EP) (LC) Reg]. *[Amended in June 2012 and June 2016]*

PART VIII : NON-COMPLIANCE AND CONSEQUENCES

Enforcement and Penalties

8.61 A candidate who fails to comply with the requirements set out in Parts VI and VII above commits an offence and is liable to a fine at level 2 (i.e. \$5,000) and to imprisonment for 6 months [s 105(9) of the EAC (EP) (LC) Reg]. *[Amended in June 2012]*

8.62 Each candidate must observe and comply with the conditions imposed by the permissions or authorisations for the display of EAs. Any EAs displayed in contravention of these guidelines will be removed and seized. Candidates and their supporters should report any non-compliance to the RO and should not take removal action themselves against any unauthorised or offending EAs. *[Amended in June 2016]*

8.63 Any unauthorised or offending EAs displayed may be seized, disposed of, destroyed, covered or obliterated by the RO or any person authorised by him/her as he/she thinks fit [s 107 of the EAC (EP) (LC) Reg]. The candidate or his/her election agent responsible may also be prosecuted and if convicted, may be liable to a fine and to imprisonment [s 105(9) of the EAC (EP) (LC) Reg]. The cost of removal, being a civil debt, will be counted as election expenses. Such civil debt must be reported in the candidate's election return. The seized articles may be kept as evidence and will be disposed of or returned upon application in accordance with the PHMSO or the Housing Ordinance (Cap 283), as the case may be, and the procedures of the relevant authority [s 104C of the PHMSO and s 24 of the Housing Ordinance]. *[Amended in October 2007, July 2008 and June 2012]*

8.64 Each candidate must observe and comply with the conditions agreed between him/her and the owner or occupier of private land or property for the display of EAs, and any additional charges or damages that a candidate is liable to pay to the owner or occupier may be construed as election expenses.

8.65 Complaints should be made to the relevant RO. Upon complaints being received, the EAC may also issue public statements in such manner as it deems fit to reprimand or censure any non-compliance with these guidelines. Although a censure may be a further detriment to the candidate in addition to his/her liability for removal expenses and criminal liability, the EAC will not hesitate to publish one in an appropriate case.

Relief for Election Advertisements

8.66 A person, who publishes an EA without complying with the requirements as set out in paras. 8.50 (except that related to the submission of permission/authorisation document under s 104A(1) of the PHMSO and consent document under s 27 of the ECICO), 8.51, 8.52, and 8.58 above may apply to the CFI for an order allowing the publication of the above EAs to be excepted from the relevant requirements and relieving him/her from the penalties. The CFI may make such an order provided that the CFI is satisfied that the non-compliance was due to inadvertence, an accidental miscalculation or any reasonable cause and was not due to bad faith. [S 106 of the EAC (EP) (LC) Reg] *[Amended in June 2012]*

PART IX: ADVERTISEMENTS OF POLITICAL, PROFESSIONAL/TRADE BODIES OR OTHER ORGANISATIONS

8.67 Any thing or material published by any organisation, including political organisation, professional or trade organisation, owners' corporation, MAC, tenants' association, owners' committee, etc. which advertises its platform or services **with reference to candidate** (irrespective of whether or not the candidate concerned is its office-bearer or member) **during or even before the election period** by name or photograph or otherwise may be treated as EA put up by, or on behalf of, or on account of, the candidate. The expenses for doing so may be construed as election expenses incurred by or on behalf of the candidate. It is therefore a prudent step for the relevant organisations to suspend such advertising activities. However, if the material published by the organisation concerned, as opposed to by the candidate himself/herself, advertises only a particular activity, which:

- (a) is organised from time to time either as part of the organisation's normal functions, and/or according to the local tradition;
- (b) is not related to the election; and
- (c) does not explicitly or implicitly promote or prejudice the election of a candidate in the election,

then the appearance in the published material of the name and/or photograph of a candidate who is involved in organising the activity will not be regarded as an EA.

8.68 It is an offence for anyone to incur election expenses unless he/she is a candidate or an election expense agent of a candidate [s 23(1) of the ECICO].

8.69 Candidates should protect their own interest by advising their political bodies or their organisations of these guidelines as soon as they have any intention or plan to run for an election.

8.70 To sum up the important points, where any organisation, including a political organisation, publishes an EA promoting a candidate:

- (a) the expenses incurred will be treated as the candidate's own election expenses;
- (b) the officer-in-charge of the organisation needs to be authorised by the candidate to be the candidate's election expense agent, or else it or the responsible person commits an offence under s 23 of the ECICO;

- (c) such advertisement must comply with the requirements of s 105 of the EAC (EP) (LC) Reg; and *[Amended in June 2012]*
- (d) such advertisement can only be displayed at the spots with the relevant written permission or authorisation. *[Amended in June 2016]*

PART X : FREE POSTAGE FOR ELECTION ADVERTISEMENTS

Conditions for Free Postage

8.71 A list of candidates for a GC/DC (second) FC or any other FC candidate who is declared to have been validly nominated in the notice of valid nominations published in the Gazette in accordance with regulations made under the EACO is permitted to post free of postage 1 letter to each elector of the constituency for which a candidate/list of candidates is validly nominated [s 43(1), (2) and (4) of the LCO]. However, before the publication of the notice of valid nominations in the Gazette, a candidate/list of candidates wishing to exercise his/her/their right to free postage may be required to furnish the Postmaster General with a security (full postage of the items posted) for the payment of postage in the event that his/her/their name is not subsequently shown in the notice of valid nominations. In the case of joint election mail, a candidate whose letters contain information on any other candidates is liable for payment of postage for all letters if the name of any of the other candidates is not subsequently shown in the notice of valid nominations. In this situation, the security payment made by the candidate will not be refunded and the relevant joint election mail will not be regarded as the candidate's letter sent free of postage. The remaining candidate(s) who is/are validly nominated is/are still entitled to exercise his/her/their right to free postage. [Reg 6(2)(a) of the Post Office Regulations (Cap 98A)] *[Amended in June 2012]*

8.72 The purpose of the free postage is to enable the candidate or candidates on the list to mail EAs to promote or advertise himself/herself/themselves in relation to that election to electors in the constituency. The free postage arrangement, which is the privilege of validly nominated candidate(s), should not be abused in any way. In particular, it cannot and should not be used for any other purpose or any other election or for promoting or advertising any other person. **As a general requirement, a candidate should publish EAs in accordance with all applicable laws and these guidelines and, in this regard, EAs sent by a candidate through free postage should not contain any unlawful content.** *[Amended in July 2008 and June 2016]*

8.73 A candidate/list of candidates, who/which is validly nominated for a GC, the DC (second) FC and the Labour FC, may choose to send joint election mails to electors [s 101A of the EAC (EP) (LC) Reg and s 43(4A), (4B) and (4C) of the LCO] in the manner as described in paras. 8.74 to 8.76 below. *[Added in June 2012]*

8.74 The letter sent by a list of candidates validly nominated for the GC may contain information on:

- (a) any number of list of candidates which is also validly nominated for that GC;
- (b) 1 single list of candidates which is validly nominated for the DC (second) FC; or
- (c) 1 single list of candidates which is validly nominated for the DC (second) FC and any number of list of candidates which is also validly nominated for that GC.

[S 43(4A) of the LCO] *[Added in June 2012]*

8.75 In the case of the DC (second) FC, the letter sent by a list of candidates may contain information on any number of list of candidates which is also validly nominated for 1 single GC. [S 43(4B) of the LCO] *[Added in June 2012]*

8.76 In the case of the Labour FC, the letter may contain information on any other candidate who is also validly nominated for that constituency. [S 43(4C) of the LCO] *[Added in June 2012]*

8.77 The letter as described in paras. 8.74 to 8.76 above will not be regarded as the letter sent by that other candidate/list of candidates. This means that other candidates/lists of candidates are still entitled to each send free of postage 1 letter addressed to each elector of the constituency concerned. [S 43(4D) of the LCO] *[Added in June 2012]*

8.78 Specifically, the letter must:

- (a) be posted in Hong Kong;
- (b) subject to paras. 8.74 to 8.76 above, contain materials relating only to the candidature of the candidate/candidates on the list, at the election concerned; *[Amended in June 2016]*
- (c) not exceed 50 grams in weight; and
- (d) be not larger than 175 mm x 245 mm and not smaller than 90 mm x 140 mm in size.

[S 101A(1) of the EAC (EP) (LC) Reg]

IMPORTANT :

Under s 101A(3)(a) of the EAC (EP) (LC) Reg, the candidate/all the candidates on the list sending postage-free mail items to electors in bulk is or are liable for payment of postage for all items in that bulk if any item in the bulk does not meet requirement (a), (b), (c) or (d) above.

In the case of joint election mails, candidates concerned should comply with the following requirements regarding (i) prior written authorisation to act as election expense agent; (ii) the sharing of expenditure in respect of the joint election mails among the candidates concerned for the purpose of submission of election return; and (iii) the obtaining of written consent of support from each other before sending the joint election mails [see paras. 18.6 and 18.8 of Chapter 18].

[Amended in October 2007, July 2008, June 2012 and June 2016]

Postal Requirements Stipulated by Hongkong Post**Make-up**

8.79 The letter may take the form of envelope, lettergramme, card or folder. Items in roll form or enclosed in plastic wrappers are **not** acceptable.

8.80 Cards and folders must be made of ordinary cardboard or paper not less than 0.25 mm thick, and must be rectangular in shape.

8.81 When a wrapper is used, it must extend over the full length of the item which it encloses. Envelopes must not be fastened with staples or with

paper fasteners with sharp edges or points, but they may be closed by means of an adhesive flap or tape.

8.82 Envelopes, folders and lettergrammes having an opening large enough to entrap smaller letters are prohibited. **Unsealed mail item** contained in envelopes with ordinary tuck-in flaps may be used up to the following size limits [s 6.3 of the Post Office Guide]:

Not over 90 mm in depth – opening
not over 150 mm in length

Not over 100 mm in depth – opening
not over 140 mm in length

Over 100 mm in depth – opening not
over 115 mm in length

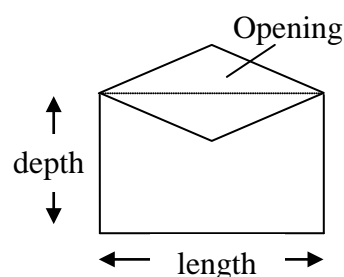

8.83 Folders (e.g. A4 size) with openings should be closed by means of adhesive flap or tape to avoid entrapping smaller letters. All open edges must not be longer than 90 mm in width. Otherwise, adhesive tapes should be applied to the midpoints of the open edges to reduce the width. For details, please refer to the illustration in **Appendix F**. [*Amended in July 2008 and June 2012*]

8.84 **The Chinese characters “選舉郵件” or “選舉廣告” or English words “Election Mail”, or “Election Advertisement” must be printed on the front (address) side of the election item, or the address side of the folder (unenvveloped mail). The layout of the election items is as follows:**

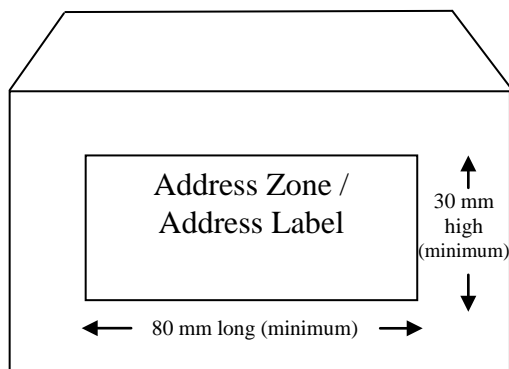
Front Side of an Election Item

The Chinese characters “選舉郵件” or “選舉廣告” or the English words “Election Mail” or “Election Advertisement” must be printed on the front (address) side of the election mail.

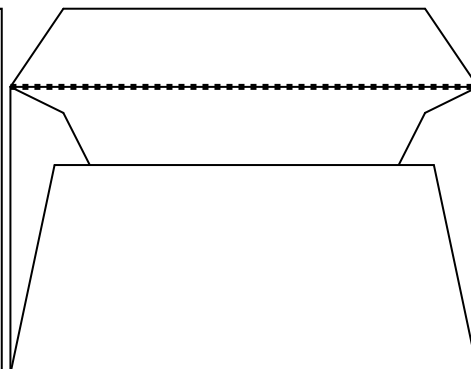
Back Side of an Election Item

[Amended in October 2007, July 2008 and June 2016]

Addressing

8.85 To avoid delay or misdelivery, the full postal address should be typed or legibly written on the front of the envelope in 4 rows as follows:

Name of addressee

Floor and flat number and name of building

Street number, name of street

Name of district

8.86 Addressing slips may be used for the mailing of EAs provided that they are legible and **securely pasted** onto the election items. *[Amended in October 2007]*

IMPORTANT :

For the purpose of posting of election mails, candidates may request the REO to provide one set of mailing labels in respect of the electors of the relevant constituencies (either produced on a “household” or an “individual” basis) and/or a “Candidate Mailing Label System” (CMLS) DVD-ROM. To protect the

environment, candidates are encouraged to use household labels. Furthermore, no mailing labels will be provided for electors who have provided their e-mail addresses to receive EAs. *[Added in June 2016]*

8.87 The name(s) of the candidate(s) and other propaganda slogans, including photographs, should appear on the back or the front (address) side of the item. An address zone of at least 80 mm long and 30 mm high, preferably at the right-hand half or at the centre of the front (address) side for the address of an elector, should be reserved exclusively for the address. If an adhesive address label is used, it should not be less than 80 mm long and 30 mm high. The address label should only contain the name and address of elector(s) and be affixed to the address zone. The whole address zone and address label should be free of advertisement and should appear on the front side of the item. The address zone and address label should be in white background colour while the characters of the postal address should be in black. *[Please refer to para. 8.84 for better illustration.] [Amended in October 2007 and July 2008]*

8.88 No postage-free EA bearing an address outside Hong Kong will be accepted. Specifically, **only 1 address of elector(s) should be shown on the postage-free election mail.** *[Amended in July 2008]*

Posting Arrangements

8.89 In order to allow adequate time for Hongkong Post to process the election mail during the election period, candidates are advised to make their postage-free EA postings **before the posting deadline as designated by Hongkong Post.** Candidates and their agents are therefore **reminded** that **postings made after the posting deadline is very unlikely to be delivered to the addressees before the polling day.** *[Amended in October 2007]*

8.90 **Candidates should apply to Hongkong Post for written approval of their EA specimens for free postage. They should carefully study the requirements governing free postage for EAs before deciding on the contents of their EAs and seek advice from Hongkong Post relating to postal requirements and the REO on other aspects as appropriate if in doubt. Candidates should make every effort to submit their EA specimens to Hongkong Post for written approval as early as possible before mass production of their EAs so as to allow sufficient time for revising the contents of their EA specimens, if necessary. [Added in June 2012]**

8.91 Candidates should present 3 unsealed specimens of their EAs, together with a Notice of Posting of Election Mail in duplicate (the notice will be provided by the REO to the candidates upon their submission of nominations) to the manager(s) at the designated post offices for written approval of their EA specimens. At least **2 clear working days** (excluding Saturday) must be allowed for the respective manager(s) at the designated post office to process each set of specimens and postings should only be made after receipt of Hongkong Post's approval. As a large number of EA specimens may have to be processed at the same time, there is no guarantee that the EA specimens will necessarily be approved in 2 working days immediately after their submission. Candidates who wish to post joint election mails should indicate their intention in the Notice of Posting of Election Mail which should be signed jointly by all the candidates/election agents concerned. The specimens of joint election mails should be submitted to the manager(s) at the designated post offices for approval as well. *[Amended in October 2007, July 2008, June 2012 and June 2016]*

8.92 Candidates should post their postage-free mail at the respective post offices/delivery offices designated by Hongkong Post for the election concerned. When making postings, the candidates should furnish a copy of the election mail for the attention of the manager(s) of the designated post

offices/delivery offices for record purpose. *[Amended in October 2007, June 2012 and June 2016]*

8.93 The postings should be made up in bundles of 50 or 100 each for easy counting. All election mails must be stacked on the same side and arranged in accordance with the same order as the address labels/address lists (e.g. by building name or block number) provided by the REO. To facilitate handling of a huge volume of postings within a tight time schedule, **candidates of GCs and the DC (second) FC** must sort their election mail according to the DC Constituency Areas when making postings at the designated post offices/delivery offices. *[Amended in October 2007, July 2008, June 2012 and June 2016]*

8.94 With each posting, the candidate or his/her election agent must present a signed declaration (the declaration form will be given to a candidate by the REO upon his/her submission of nomination) **in duplicate** (the original to be kept by Hongkong Post and the duplicate copy duly signed by Hongkong Post and kept by the candidate or his/her election agent as acknowledgement of the posting):

- (a) stating the quantity of packets in the posting and the name of the candidate;
- (b) declaring that the posting is his/her postage-free mail;
- (c) declaring that in the case of joint election mails at the election concerned each packet contains material relating only to the information as set out in paras. 8.74 to 8.76 above, as the case may be; is identical to the unsealed specimen submitted by the candidate/list of candidates or his/her/its election agent for inspection and approval by Hongkong Post; and *[Amended in July 2008, June 2012 and June 2016]*

- (d) declaring that not more than 1 postage-free mail will be sent to any of the electors. *[Amended in October 2007]*

It is important to note that under s 101A(3)(b) of the EAC (EP) (LC) Reg, a candidate sending postage-free mail items to electors in bulk is liable for payment of postage for all the items in that bulk if the declaration made by him/her or his/her election agent is false in any particular. *[Amended in October 2007, July 2008, June 2012 and June 2016]*

8.95 If a candidate makes posting in more than 1 batch, the same declaration form should be presented at the same designated post office/delivery office on each occasion. *[Amended in June 2012]*

8.96 If the name, logo or pictorial representation of a person or an organisation, as the case may be, is included in the election mail, and the publication is in such a way as to imply or to be likely to cause electors to believe that the candidate(s) has/have the support of the person or organisation concerned, the candidate(s) should ensure that **prior written consent** has been obtained from the person or organisation concerned. [Please refer to Chapter 18 for the detailed requirements.] *[Added in June 2016]*

8.97 Government reserves the right to charge a candidate postage where any of the requirements under s 101A(3) of the EAC (EP) (LC) Reg is not met or the free postage arrangements are abused in any way. The charge counts towards the candidate's election expenses and must be included in his/her election return to be sent to the CEO. The EAC may also issue public statements in such manner as it deems fit to censure any abuse of the free postage arrangements. *[Amended in July 2008]*

8.98 **The postal requirements stated in the above guidelines (paras. 8.79 to 8.96) are quoted for general reference only. Candidates should**

comply with the latest requirements issued by Hongkong Post at the time of the election concerned. *[Added in July 2008]*

Enquiries

8.99 For general enquiries concerning the posting of EAs, please contact:

Assistant Manager (Retail Business Support)

Room 1M05

General Post Office

2 Connaught Place

Central

Hong Kong

Telephone: 2921 2190 / 2921 2307

Fax: 2501 5930

[Amended in October 2007, July 2008, June 2012 and June 2016]

**PART XI : ELECTION ADVERTISEMENTS FOR REGISTERED
ELECTORS AND AUTHORISED REPRESENTATIVES
IN THE CUSTODY OF CSD AND OTHER LAW
ENFORCEMENT AGENCIES**

8.100 Candidates may send EAs to registered electors/ARs in the custody of the CSD where the electors/ARs have provided the addresses of the penal institutions concerned as their correspondence addresses for the receipt of EAs. For security reasons, candidates should adhere to the guidelines laid down by CSD at **Appendix T** when sending EAs to these electors/ARs.

[Added in January 2010 and amended in June 2016]

8.101 Candidates may note that persons who are in prison or held in custody by the law enforcement agencies who are registered electors/ARs may access election-related information through the mass media in accordance with the existing policies of the law enforcement agencies on access to the mass media. *[Added in January 2010]*

CHAPTER 9

ELECTIONEERING ACTIVITIES AT PREMISES OR BUILDINGS WHERE ELECTORS RESIDE, WORK OR FREQUENT

PART I : GENERAL

9.1 There are occasions when candidates may wish to target their electioneering activities at an individual elector or a group of electors at:

- (a) his/her/their living/working places;
- (b) the premises of the organisation(s) to which the elector(s) belong;
or
- (c) the building(s) which the elector(s) frequent.

These electioneering activities may include visits to, personal contact with people, using amplifying devices to advertise in the common parts of the building, display or distribution of EAs and holding of election meetings at, the places mentioned above. **Appendix G** gives some kind of reference as to what activity is to be regarded as an electioneering activity. This chapter explains the general guidelines to be observed by candidates in conducting electioneering activities, the rights of all concerned and appeals to the electors, the management bodies of the organisations to which the electors belong and the management bodies of the buildings which the electors frequent to **provide fair and equal treatment** to all candidates so as to ensure that the election is conducted fairly. *[Amended in October 2007]*

9.2 Candidates are reminded that different organisations/buildings may have their own guidelines to allow or disallow the conduct of electioneering activities on the premises under their management. To ensure the smooth conduct of electioneering activities in public or private places, candidates should consult the relevant authorities or management in advance and, if required, obtain prior permission from them for the conduct of electioneering activities in the places within their jurisdiction. *[Added in October 2007]*

9.3 The general guidelines to be observed for conducting electioneering activities at the living and working places of electors, premises of organisations to which electors belong and buildings which electors frequent are set out in Part III below. The specific guidelines to be observed for conducting electioneering activities in the premises managed by the Housing Department and the Hong Kong Housing Society are set out in **Appendix H**. *[Added in October 2007]*

9.4 For the purpose of ensuring fair treatment and equal opportunity of access for all candidates in conducting electioneering activities and to avoid causing undue disturbance to the public, Part IV below provides the owners/management of premises and organisations with some guidelines in handling applications for conducting electioneering activities in the premises under their control. *[Added in October 2007]*

PART II : RIGHTS OF TENANTS AND OWNERS

Tenant's Right – His/Her House, Flat, Office or Factory

9.5 The tenant who has exclusive possession of a house, flat, office or factory, and not the owner, has the right to allow or deny access by anyone to the place.

Common Parts

9.6 The **common parts** of a building (those parts to which exclusive rights of use or occupation do not belong to a particular owner or tenant) are usually under the control and management of the owners of the various units in the building. Where there is an owners' corporation of the building incorporated under the former Multi-storey Buildings (Owners Incorporation) Ordinance or the present Building Management Ordinance (Cap 344), the control and management of the common parts are exercised by the owners' corporation representing all the owners of the building.

9.7 The carrying out of the powers and duties and the acts of an owners' corporation do not affect the rights of the tenants of the individual flats, offices or factories in the building except in relation to matters concerning the common parts. Candidates and tenants should note that as **a tenant** has exclusive possession of the unit that he/she occupies, he/she **has the right to invite anyone to visit his/her unit for any lawful purpose**, including electioneering, but he/she has no right to allow the invitee to approach other tenants' units, such as knocking on other people's doors, or to do anything in the common parts of the building, except for accessing and leaving his/her unit or for the purposes allowed by the owners.

Owners' Committees

9.8 In some buildings, no owners' corporation has been established, but instead an owners' committee is formed. While an owners' committee generally operates in the same manner as an owners' corporation, its powers vis-à-vis the rights of the individual owners are not standardised and may differ from case to case.

Management Companies

9.9 Very often, the management of the common parts of a building has been delegated by the owners or owners' corporation or owners' committee to a management company. Management companies are only managing the common parts on behalf of the owners and unless specifically empowered to do so, have no independent right or power to decide whether electioneering by candidates in the common parts should or should not be allowed.

Tenants' Associations, Residents' Associations, MACs

9.10 Sometimes there are tenants' associations or residents' associations or MACs representing tenants' interests in buildings. As against the owners, they have no right to control or manage the common parts. If they are given the authority by the owners, then they are entitled to control and manage the common parts on behalf of the owners.

PART III : GUIDELINES TO BE OBSERVED BY CANDIDATES IN THE CONDUCT OF ELECTIONEERING ACTIVITIES

Visits to Living and Working Places of Electors

9.11 Candidates should note that electors have the right to allow or deny access by anyone, including the candidates, to their own living or working places. In other words, electors are free to invite, or accept the request from, a particular candidate(s), but not the others, to visit them at their living or working places.

9.12 However, access to a private office may require the approval of the management of the office building or the companies which employ the electors, and such management when making a decision should have due

regard to the fair and equal treatment principle mentioned in Part IV below. In conducting electioneering activities at the common parts of the living or working places of electors, candidates should observe the general guidelines set out in paras. 9.15 to 9.22 below. *[Added in October 2007]*

9.13 Any government offices, which are working places of electors, will be treated in the same manner as the premises referred to in this chapter. Government offices may allow or disallow electioneering activities as they wish, but such decision should comply with the fair and equal treatment principle mentioned in Part IV below. *[Amended in October 2007]*

9.14 Due to security reasons, arrangements will not be made to facilitate in-person canvassing activities in a prison or the premises of a law enforcement agency. A visitor, who visits a prison or the premises of a law enforcement agency for a business or official purpose, is not allowed to canvass for votes. This is to ensure that such a visitor will not have an advantage over other persons who cannot make the visit. A person, who canvasses for votes during the aforesaid visit, commits an offence and will be liable to a fine at level 2 (\$5,000) and to imprisonment for 3 months [s 90A of the EAC (EP) (LC) Reg]. *[Added in January 2010]*

Respect for the Decision and Privacy

9.15 After a candidate/list of candidates has been notified of the decision relating to electioneering activities, he/she/they should ensure that he/she/they and his/her/their supporters comply with the decision and should not avail himself/herself/themselves of or obtain any unfair advantage over any other candidate(s)/list(s) of candidates. *[Amended in October 2007 and June 2012]*

9.16 If a decision to disallow electioneering in an organisation or a building has been made, the candidate or his/her supporters should conduct no

electioneering activity in such places. If the candidate concerned acts against the decision of the organisation or building in whatever manner, then he/she commits trespass and the organisation or building management can simply stop him/her from doing the contravening act or carry out the decision to exclude the candidate concerned. If the candidate refuses to leave, it would be wise in such circumstances for the organisation or building management, as the case may be, to report the matter to the Police in the first instance and then to the EAC which may publish a reprimand or censure against the candidate concerned. *[Amended in October 2007]*

9.17 A candidate and his/her supporters should respect the decisions of the organisation or building management, and it is unwise to enter into **arguments** with members of the organisation or the building residents who obstruct the candidate's electioneering inside the premises of the organisation or the building. Such arguments may affect the candidate's reputation or image with members of the organisation or the residents of the building. Any dissatisfaction with the decision or act of the organisation or the building should more properly be made a subject of a complaint as soon as possible to the EAC or its Complaints Committee which will decide whether the decision or act is fair or unfair. *[Amended in October 2007]*

9.18 **Privacy of the electors should be respected.** The guidance note on personal data privacy in respect of electioneering activities at **Appendix I**, prepared by the Office of the Privacy Commissioner for Personal Data ("OPCPD"), serves as a general reference on compliance with the requirements of the PD (P) O in relation to electioneering activities that may involve the collection and use of personal data of an individual. According to the aforesaid guidance note, the act of canvassing for votes is not in contravention of the PD (P) O provided that collection and handling of personal data is in compliance with the data protection principles in schedule 1 to the PD (P) O. The aforesaid guidance note also reminds candidates, inter alia, that:

- (a) individuals should be informed of the purpose of collection of their personal data when collecting the data directly from them for electioneering;
- (b) personal data should not be collected by deceptive means or by misrepresentation (e.g. collecting personal data in the pretext of opinion poll or assisting citizens to apply for government welfare);
- (c) before using personal data from sources other than the extract from the Final Register provided by the REO for electioneering purpose, express consent from the data subjects should be obtained unless the original purpose of collection of the data is directly related to the electioneering purpose; and
- (d) if election agents or other contractors are engaged to process personal data of electors/ARs on behalf of the candidates for electioneering purpose, necessary means (contractual or otherwise) must be adopted to prevent the personal data transferred to the election agents or other contractors from: (i) being kept longer than is necessary for the electioneering purpose; and (ii) unauthorised or accidental access, processing, erasure, loss or use.

[Added in June 2016]

In addition, in order to facilitate better understanding of the privacy concerns of the electors and compliance with the requirements of the PD (P) O, the OPCPD has provided 4 complaint cases at **Appendix J** for illustration purpose. **Candidates and their election agents are strongly advised to strictly follow the guidance provided by the OPCPD in the aforesaid note when conducting electioneering activities.** *[Amended in June 2012 and June 2016]*

9.19 Candidates/lists of candidates are supplied by the REO with an **extract of the Final Register** in respect of their respective constituencies which contains the name and residential address of electors of the relevant constituency and their email addresses (where the electors concerned have provided to REO for the purpose of receiving EAs from candidates), but **not their telephone numbers**. As a general rule, candidates/lists of candidates should respect elector's privacy when using their contact information for canvassing. In particular, for mass distribution of EAs over email, candidates/lists of candidates are reminded to use the "bcc" function of email or other proven means to ensure that the email addresses of individual electors would not be inadvertently disclosed to other recipients. Candidates/lists of candidates should note that some members of the public do not like or detest being called over the telephone, the entrance intercom system and some do not like their names being called out aloud. Many electors also consider canvassing messages sent to them through electronic devices annoying. Their disapproval may be reflected in their choice of candidates/lists of candidates on the polling day. It is therefore unwise to call or send messages through electronic devices to electors who find such approaches objectionable or to act in any other way that may antagonise them. As a matter of good practice, candidates/lists of candidates and their supporters should maintain a list of electors that they know finding such electioneering telephone calls or messages or visits objectionable and avoid approaching these electors through these means again. On the other hand, electors who receive the objectionable telephone calls or messages can just disconnect them. If the caller or sender does not desist from calling or sending messages and causes a nuisance, the elector should report the matter as soon as possible to the **Police** who may take action against the caller or sender. *[Amended in October 2007, July 2008, June 2012 and June 2016]*

9.20 Some candidates or their supporters may use **loud-hailers** to assist their campaign. They should exercise restraint in the use of loud-hailers

so as not to create a nuisance to the persons in the vicinity, including those who live in the buildings nearby. They should be mindful that some people working shift hours need to take rest during the daytime and the noise generated from the use of loudspeakers for electioneering activities may affect their daily life. In order to reduce the nuisance caused to members of the public, candidates are required **not** to use loudspeakers in electioneering **between 9 pm and 9 am**. If the EAC comes to know that a candidate/list of candidates has breached the time restriction, it may make a reprimand or censure against the candidate/list of candidates. Excessive noise will amount to an offence and the Police may be called. Anyway, it is unwise to create a nuisance through the use of loud-hailers, for the annoyance of the electors will obviously be reflected in their choice of candidate. [See also Chapter 12] *[Amended in October 2007 and June 2012]*

9.21 Canvassing through the use of the **entrance intercom system** in a building is prohibited unless it is expressly allowed by the building management. *[Amended in October 2007 and July 2008]*

Identification of Canvassers

9.22 For security reasons and for prevention of abuse, the EAC advises that each candidate should provide some forms of identification to his/her canvassers for them to enter the premises of an organisation or a building for electioneering purposes. The EAC suggests that the candidate should devise an authenticated identification document containing the name and photograph of his/her canvasser who should produce his/her identification document together with his/her identity card for inspection to gain entry into the premises of an organisation or a building. Candidates should note that the production costs of this kind of identification document will be counted as election expenses. *[Amended in October 2007]*

**PART IV: GUIDELINES TO BE OBSERVED BY OWNERS,
MANAGEMENT AND ORGANISATIONS FOR
HANDLING APPLICATIONS FOR CONDUCT OF
ELECTIONEERING ACTIVITIES ON THE
PREMISES WITHIN THEIR JURISDICTION**

**Electioneering at Premises of Organisations to which Electors Belong and
Buildings which Electors Frequent**

9.23 The premises of the organisations to which the electors belong and the buildings which electors frequent usually do not belong to a particular elector or group of electors. They are usually under the control of the management bodies of the organisations or the buildings concerned.

9.24 On the polling day or even quite some time before, candidates and their supporters may wish to carry out canvassing or electioneering activities at the premises mentioned above. Such activities mainly consist of the following:

- (a) distribution of election leaflets or advertisements by delivering them into the flats themselves, or into mail boxes of the flats, or placing them in the common parts of the building for collection, or handing them out to residents or people in the common parts of the building (but not distribution by post which is not subject to the control of the private premises);
- (b) display of posters, banners, placards, boards and any other EAs, etc. at any of the places within the common parts of the building;

NOTE :

Candidates who are allowed to display or distribute EAs at the premises mentioned above must comply with the guidelines set out in Chapter 8. *[Amended in October 2007]*

- (c) personal contact with people or using amplifying devices to advertise in the common parts of the building; and
- (d) household or home visits to occupiers of flats.

[Amended in October 2007]

9.25 **A tenant's right to invite lawful visitors to his/her own flat or office or factory cannot be lawfully restrained by any decision made by the owners or owners' corporation.** If he/she invites a candidate and his/her supporters into his/her own premises, the owners or owners' corporation have no right to stop or obstruct it.

Decision to be Made at a Tenants' Meeting

9.26 During election time, there may be tenants wishing to entertain the approaches by candidates and their supporters, but different tenants may invite different candidates to their units, and there may be arguments as to which candidate should be allowed to electioneer in the building. It is therefore advisable for owners or owners' corporations to make a decision on whether to allow candidates and their supporters to conduct electioneering activities in the building, so that arguments relating to who is allowed and who is not allowed to do so will be resolved for the benefit of all concerned. It is also advisable for owners or owners' corporations to invite all the tenants to attend the meeting held for discussing this matter so that tenants' views will be heard before any decision to allow or deny electioneering activities in the

building is taken.

9.27 As a motion on whether or not electioneering should be allowed in a building concerns the rights of tenants and occupiers more than those of owners, it is advisable for owners or owners' corporations to allow occupiers who are not owners to vote on the motion and a secret ballot is always the fairest way of voting on such a controversial subject. If approval or consent has been obtained from the owners having the control of the common parts of the building or the owners' corporation, the building management organisation may conduct a questionnaire survey to collect the views of the occupiers of each flat and act according to the majority view relating to matters covered by and in accordance with this chapter.

9.28 Candidates in an election see electioneering as a form of freedom of expression whereby they express to electors their platforms and the electors have a corresponding right to receive such information. Electors can only make a proper choice when casting their votes if they know the platforms of each of the contesting candidates.

9.29 If a decision is made to allow electioneering by all candidates, the decision can also set out the hours of access and other conditions, such as not causing annoyance to occupiers, and the maximum number of persons allowed for home visits, etc. for the candidates to comply [see also **Appendix K**].
[Amended in October 2007]

Decision Must Provide Fair and Equal Treatment

9.30 The EAC appeals to all management bodies of the organisations or buildings concerned to provide **equal opportunity** to all candidates/lists of candidates competing in the same constituency for the purposes of electioneering. However, if it is decided **not** to allow a particular candidate/list of candidates to conduct electioneering activities at the premises

of the organisation or in the common parts of the building, no other candidate/list of candidates in the same constituency should be allowed to do so, **for it is important to provide fair and equal treatment for all candidates/lists of candidates** so as to ensure that the election is conducted fairly. Discriminatory treatment of candidates may also lead to unequal treatment of tenants, and have the undesirable effect of giving rise to dissatisfaction and discord amongst neighbours in the same building. *[Amended in June 2012]*

9.31 For all types of building organisations, be it an owners' corporation, owners' committee, MAC, tenants' association, residents' association, management company or managers of the building, the decision that it makes relating to electioneering activities of candidates in the common parts of the building, including the office premises of the organisation and all private streets, etc., **must comply with the fair and equal treatment principle.**

IMPORTANT :

The office bearers of building organisations must not abuse their positions in the organisations to give unfair treatment to any candidate in the conduct of electioneering or canvassing activities in the buildings concerned. This is particularly the case when the office bearers themselves or their close relatives are candidates in the election. Furthermore, it would be the responsibility of the building organisations to ensure that the fair and equal treatment principle is strictly complied with in all circumstances and no candidates will be given unfair advantage in the election. *[Added in June 2016]*

9.32 The organisation concerned should make a decision that applies equally and fairly to all candidates/lists of candidates of each constituency

instead of dealing with each application from them separately. This will avoid having to convene a meeting to deal with each application upon its receipt, sometimes incurring delay in dealing with some applications. The EAC may treat such delay as a device to avoid compliance with the fair and equal treatment principle and may issue a reprimand or censure. *[Amended in June 2012]*

Notification of Decision

9.33 The management bodies of organisations and buildings are urged to notify the relevant RO in writing as soon as possible of their decision on electioneering by candidates, so as to equip the RO with the correct information to be provided to the candidates who may make inquiries with him/her. A **form** of notification to the RO can be obtained from the REO. Enquiries may be made with the DO or sub-offices of the District in which the building is located. Nevertheless, candidates are advised to note that some buildings may not be able to make a decision on electioneering by candidates before the end of nomination period and therefore have not given the notification to the RO as required. When candidates come across these buildings, they should respect the interim decision of these buildings not to allow electioneering.

Display of Election Advertisements

9.34 The management bodies of the organisations or buildings concerned should avoid handling applications by candidates/lists of candidates for display of EA on a first-come-first-served basis as this may create unfairness. For example, if one candidate/list of candidates knows the decision and applies to put up posters and banners on all available spots in the common parts of the building, no space will be left for other candidates/lists of candidates who apply after him/her/them. To ensure fairness, management bodies are advised to:

- (a) ascertain all the available spots at the premises for candidates/lists of candidates to display posters and banners;
- (b) decide on the maximum size of posters and banners to be allowed; *[Added in October 2007]*
- (c) after the close of nominations of candidature, find out from the relevant RO how many candidates/lists of candidates are contesting in the constituency/constituencies concerned;
- (d) divide all the available spaces according to quality and quantity to ensure equality as far as possible into portions equivalent to the number of candidates/lists of candidates in the constituency/constituencies concerned;
- (e) when one of the candidates/lists of candidates of the constituency concerned applies for display of EAs, allow him/her/them to draw lots to obtain a portion of the spots still available at the time of his/her/their application; and
- (f) where 2 or more candidates/lists of candidates wish to display their joint EAs, they should be allowed to do so but the joint EAs should occupy no more than the total of all the portions of the spots allocated to them by the restriction of size under (b) and the drawing of lots under (e) mentioned above. *[Added in June 2012]*

9.35 If a building has any spaces in the common area that can be made available through any arrangement including rental for candidates to display EAs or conduct other electioneering activity, the building shall ensure that such spaces are **equally available** to all the candidates/lists of candidates contesting the same constituency, and give reasonable notice to all such candidates

accordingly. Providing a space to only one of the candidates/lists of candidates but not the others will be considered to be offering an unfair advantage to the candidate/list of candidates concerned and operating unfairly towards the other candidates/lists of candidates. Candidates should not take any such unfair advantage. *[Amended in June 2012]*

9.36 Where a decision has been made, notice of its contents together with the conditions should be posted up at the entrance so that candidates or their agents will be able to know. This openness will help prevent misunderstanding and complaint.

9.37 Whenever a decision has been taken by a building, insofar as the decision does not offend against the fair and equal treatment principle regarding electioneering activities of all candidates/lists of candidates of the same constituency, and such decision is not carried out unfairly towards any of the candidates/lists of candidates, the EAC will not intervene. *[Amended in June 2012]*

9.38 An owners' corporation or other organisation or person should be very careful not to incur any election expenses for promoting a candidate/list of candidates, such as putting up a banner to show support for a candidate/list of candidates, because it is an illegal conduct at an election for a person, other than a candidate or a candidate's election expense agent, to incur election expenses at or in connection with the election [s 23(1) of the ECICO]. *[Amended in June 2012]*

9.39 Any person who puts up any publicity materials, including those which do not look election-related, in the nomination period on private premises should declare to the management body concerned in writing whether he/she is a candidate or intends to stand as a candidate in the election. This is to prevent a prospective candidate from making use of such device to promote himself/herself. The management body is also advised to exercise its own

judgment on whether the publicity materials are serving electioneering purposes and then make a decision with due regard to the fair and equal treatment principle.

PART V: CONDUCT OF ELECTIONEERING ACTIVITIES IN PREMISES UNDER THE MANAGEMENT OF HOUSING DEPARTMENT AND HONG KONG HOUSING SOCIETY

9.40 The specific guidelines to be observed by candidates and their agents in the conduct of electioneering activities in premises under the management of the Housing Department and Hong Kong Housing Society are set out in **Appendix H**. *[Amended in October 2007]*

PART VI: SANCTION

9.41 If the EAC receives a complaint of unfair or unequal treatment of candidates by any organisation or building or a person acting or purporting to act on behalf of such organisation or building, and is satisfied that the complaint is justified, it may make a **reprimand** or **censure** in a public statement which will include the names of the candidates/lists of the candidates favourably and unfavourably treated. Candidates should therefore advise the organisation management or building owners whom they approach of these guidelines. On the other hand, however, if it is proved that a person has made a false, unfounded or unreasonable allegation of unfair treatment by an organisation or a building, the EAC may issue a reprimand or censure in a public statement against that person. *[Amended in July 2008 and June 2012]*

9.42 Candidates should also refrain from accepting any unfair advantage over other candidates in the same constituency even though such

may be ready on offer by an organisation or a building. The EAC may publish a public **reprimand** or **censure** against the candidate who contravenes the guidelines in this chapter or whose act or behaviour results in any unfair or unequal treatment by organisation or buildings towards any other candidate.

CHAPTER 10

ELECTION MEETINGS

PART I : GENERAL

10.1 An **election meeting** is a meeting held to promote or prejudice the election of a particular candidate or particular candidates [s 12(5) of the ECICO]. For the avoidance of doubt, election forums organised for all candidates in the same constituency are not treated as election meetings [see Part IV of Chapter 11]. During the election period, a candidate may attend any other meetings as part of his/her normal activities which are **not election-related**. Insofar as such meetings are **not** held for the purpose of promoting or prejudicing the election of a particular candidate or particular candidates, they will not be regarded as election meetings. *[Amended in October 2007]*

10.2 Expenses incurred before, during or after the election on account of an election meeting organised for any of the purposes stated above are **election expenses** [s 2 of the ECICO]. There may be cases where a meeting is not organised for any of the above purposes, but has nevertheless been used for such purposes by a candidate or any other person on his/her behalf. In that event, it will be for the candidate to assess the expenses which have been incurred for the said purposes. [See Chapter 16] The person who uses the meeting for promoting the candidate may also be liable for prosecution for his/her failure in obtaining the candidate's prior authorisation to appoint him/her as the candidate's election expense agent for incurring election expenses on behalf of the candidate [s 23(1) of the ECICO].

10.3 Candidates should refer to the part on "Treating" in Part IV of

Chapter 17, regarding the serving of drinks and meals at or incidental to an election meeting.

10.4 In addition to the election expenses incurred, candidates are responsible for the election meetings or public processions which they organise, including the keeping of order and safety, controlling noise level, cleanliness and other liabilities.

10.5 An election meeting may take place in a public place or at private premises. A public procession for election campaigning purposes is a form of election meeting, as is an exhibition organised with a view to promoting or prejudicing the election of a particular candidate or particular candidates.

10.6 Candidates are reminded that individual government departments and management authorities may have their own guidelines to allow or disallow the conduct of election meetings on the premises under their control. To ensure the smooth conduct of election meetings in public or private places, **candidates should consult the relevant authorities concerned in advance and if required, obtain prior permission from each of them for the conduct of election meetings on the premises within their jurisdiction.** *[Added in October 2007]*

10.7 The requirements of the Hong Kong Police Force for the organisation of election meetings in public places and the guidelines of the Housing Department/Hong Kong Housing Society for premises under their jurisdiction are set out in paras. 10.8 to 10.19 below. *[Added in October 2007]*

PART II : ELECTION MEETINGS IN PUBLIC PLACES

10.8 Any person who organises an election meeting in a public place

must notify the Commissioner of Police in writing **not later than 11 am on the same day (if a general holiday, the first day immediately preceding that day which is not a general holiday) of the week in the preceding week as the day on which the meeting is intended to be held** [s 8(1) of the Public Order Ordinance (Cap 245) (“POO”)]. “Public place” means any place to which for the time being the public or any section of the public are entitled or permitted to have access, whether on payment or otherwise, and, in relation to any meeting, includes any place which is or will be, on the occasion and for the purposes of such meeting, a public place [s 2 of the POO].

10.9 The written notification shall be **handed in** to the officer in charge of any police station. It should contain the following particulars:

- (a) the name, address and telephone number of the person organising the meeting, any society or organisation promoting or connected with the holding of the meeting and a person able to act, if necessary, in place of the organiser;
- (b) the purpose and subject matter of the meeting;
- (c) the date, location, time of commencement and duration of the meeting;
- (d) an estimate of the number of people expected to attend the meeting;
- (e) the number and names of persons proposed as platform-speakers for the meeting;
- (f) the sound amplification devices, if any, intended to be used at the meeting; and

- (g) the nature, form and contents of the advertisements, printed matter, posters or banners intended for publication, distribution or display in respect of the meeting.

[S 8(4) of the POO] *[Amended in October 2007]*

A **form** of notification for a public meeting or procession together with guidance notes provided by the Police will be given to a candidate upon his/her submission of nomination. The Police has advised that the use of the form will speed up processing time.

10.10 Notification to the Commissioner of Police of an election meeting is not required if the meeting is to be:

- (a) attended by not more than 50 persons; or
- (b) held at the private premises where the number of persons attending will not exceed 500 persons; or
- (c) held in a school registered or provisionally registered or exempted under the Education Ordinance (Cap 279), college registered under the Post Secondary Colleges Ordinance (Cap 320), or educational establishment established by any Ordinance with the approval of an accredited society or similar body of such school, college or educational establishment **and** consent of the governing body of the establishment concerned. *[Amended in June 2016]*

[S 7(2) of the POO]

Where in doubt, a candidate should seek advice from the Police. *[Amended in June 2016]*

10.11 The Commissioner of Police may prohibit the holding of any public meeting notified (referred to in paras. 10.8 and 10.9 above) where he/she reasonably considers such prohibition to be necessary in the interests of national security or public safety, public order or the protection of the rights and freedoms of others, and if so, he/she shall give notice of the prohibition to the person who gave the notification or to any person named in that notice not later than 48 hours prior to the time of commencement of the meeting or by publication in writing in such manner, or by posting a notice of the prohibition in such place, as the Commissioner of Police may think fit [s 9 of the POO]. On the other hand, the Commissioner of Police may give notice to the organisers and impose conditions for the meeting to take place, and the organisers must comply with such conditions and comply forthwith with any direction given by a police officer for ensuring compliance with or the due performance of the conditions and the requirements referred to in para. 10.12 below [s 11(2) and (3) of the POO]. *[Amended in October 2007 and June 2016]*

10.12 At every public meeting:

- (a) there shall be present throughout the meeting either the organiser, or if he/she is not present, a person nominated by him/her to act in his/her place;
- (b) good order and public safety shall be maintained throughout the meeting; and
- (c) the control of any amplification device that is used in such a manner that it causes a noise that would not be tolerated by a reasonable person shall, if so required by a police officer, be surrendered to the police officer for the duration of the meeting.

[S 11(1) of the POO]

10.13 A guidance note on safe conduct of election-related activities, is at **Appendix K**. It serves as a general advice to candidates and organisers of election-related activities, to enable them to conduct such activities safely.
[Added in October 2007]

Public Processions

10.14 A public procession for election campaigning purposes may be held without notification to the Commissioner of Police where:

- (a) it consists of not more than 30 persons; or
- (b) it is held at a place other than a public highway, public thoroughfare or public park; or
- (c) it is of a nature or description specified by the Commissioner of Police by notice in Gazette.

[S 13(2) of the POO] *[Amended in June 2016]*

10.15 In all other cases, written notification of a public procession, including a vehicle procession, must be given by the person organising the procession or by any person on his/her behalf, to the Commissioner of Police (which may be handed in to the officer in charge of any police station) **not later than 11 am on the same day (if a general holiday, the first day immediately preceding that day which is not a general holiday) of the week in the preceding week as the day on which the procession is intended to be held** containing the following information:

- (a) the name, address and telephone number of the person organising

the procession, any society or organisation promoting or connected with the holding of the procession and a person able to act, if necessary, in place of the organiser;

- (b) the purpose and subject matter of the procession;
- (c) the date, precise route, time of commencement and duration of the procession;
- (d) in respect of any meeting to be held in conjunction with the procession, the location, time of commencement and duration of the meeting; and
- (e) an estimate of the number of people expected to attend the procession.

A notification **form** mentioned in para. 10.9 should be used. [S 13A(1) and (4) of the POO] [*Amended in June 2016*]

10.16 The Commissioner of Police may object to a public procession being held if he reasonably considers that the objection is necessary in the interests of national security or public safety, public order or the protection of the rights and freedoms of others. If the Commissioner of Police objects to the public procession being held, he shall as soon as reasonably practicable and within the time limit specified under POO –

- (a) notify in writing the person who gave notice under s 13A of the POO or a person named for the purposes of s 13A(4)(a)(i) of the POO of his objection and reasons; or
- (b) publish a written notice of objection and reasons in the manner he thinks fit; or

- (c) post a written notice of objection and reasons in the place he thinks fit.

[Ss 14 and 15(2) of the POO] *[Amended in June 2016]*

10.17 The Commissioner of Police shall not issue a notice of objection for a public procession –

- (a) if notice of a procession is given in accordance with s 13A(1)(b) of the POO, later than 48 hours before the notified commencement time of the procession;
- (b) if shorter notice of 72 hours or more is accepted by the Commissioner of Police under s 13A(2) of the POO, later than 24 hours before the notified commencement time of the procession; or
- (c) if shorter notice of less than 72 hours is accepted by the Commissioner of Police under s 13A(2) of the POO, later than the notified commencement time of the procession.

[S 14 of the POO] *[Amended in October 2007 and June 2016]*

10.18 At every public procession:

- (a) there shall be present throughout the procession either the organiser of the procession, or if he/she is not present, a person nominated by him/her to act in his/her place;
- (b) good order and public safety shall be maintained throughout the procession; and

- (c) the control of any amplification device that is used in such a manner that it causes a noise that would not be tolerated by a reasonable person shall, if so required by a police officer, be surrendered to the police officer for the duration of the procession.

[S 15(1) of the POO]

PART III : ELECTION MEETINGS AT PRIVATE PREMISES

10.19 Any person who organises an election meeting at private premises should consult the owner, occupier, owners' corporation, building management or the MAC concerned, etc. in advance and, if required, obtain prior permission from them. Insofar as the decision regarding election meetings by candidates in the common areas of a building accords fair and equal treatment to all candidates, the EAC will not intervene. Specific guidelines for conducting election meetings in the premises managed by the Housing Department and the Hong Kong Housing Society are set out in **Appendix H**. *[Amended in October 2007]*

10.20 Notification in writing to the Commissioner of Police will need to be given, in accordance with the procedures set out in paras. 10.8 and 10.9 above, if at the proposed meeting the attendance will exceed 500 persons.

PART IV : ELECTIONEERING EXHIBITIONS

General

10.21 A candidate may hold an exhibition for election campaigning purposes. If such an exhibition is to be held, the candidate should consult the

relevant management authorities of the premises concerned in advance, and, if required, obtain prior permission from the housing manager, owner, occupier, owners' corporation, building management or the MAC concerned, etc. Relevant guidelines in the other parts in this chapter should also be observed, in addition to compliance with regulations and conditions imposed by other relevant authorities. *[Amended in October 2007]*

Premises under the Purview of the Housing Department and the Hong Kong Housing Society

10.22 Where approval has been given by a housing manager for such an exhibition in housing estates managed by the Housing Department and the Hong Kong Housing Society, the display of EAs at the venue of the exhibition will normally be subject to the conditions that they are displayed in connection with the activity in question and for a temporary duration of less than a day. The guidelines in Chapter 8 are applicable to such displays and must be observed by the candidate concerned. The housing manager should send a copy of the letter of approval to the relevant RO for record and for public inspection. Please also see **Appendix H** for reference. *[Amended in October 2007]*

PART V: FUND RAISING ACTIVITIES AT ELECTION MEETINGS

10.23 A permit is required for organising, providing equipment for, or participating in any collection of money or sale of badges, tokens or similar articles or exchange the same for donations in a public place [s 4(17) of the Summary Offences Ordinance (Cap 228)]. Any person who wishes to raise funds at an election meeting for non-charitable purposes should apply to the Secretary for Home Affairs. A copy of the administrative guidelines and licensing conditions for the issue of such permits with an application form is at **Appendix L** for general information.

CHAPTER 11

ELECTION BROADCASTING, MEDIA REPORTING AND ELECTION FORUMS

PART I : GENERAL

11.1 This chapter deals with election broadcasting through electronic means (which covers all programmes including those on current affairs and news reporting of the radio and television stations licensed under the Broadcasting Ordinance (Cap 562) and the Telecommunications Ordinance (Cap 106)), media reporting on election-related matters and the holding of any election forum. *[Amended in June 2016]*

IMPORTANT :

“Candidate” includes a person who has publicly declared an intention to stand for election at any time before the close of nominations for the election, whether or not he/she has submitted a nomination form [s 2 of the ECICO]. The reference of “candidate” in this chapter includes a list of candidates in a GC/DC (second) FC to which the list system of proportional representation applies. *[Amended in June 2012]*

PART II : ELECTIONEERING ON TELEVISION AND RADIO

11.2 Operators of television broadcasting services licensed under the Broadcasting Ordinance are not allowed under the law to broadcast advertisements of a political nature. Operators of radio broadcasting services

licensed under the Telecommunications Ordinance are not allowed under the Code of Practice issued by the Communications Authority to broadcast advertisements of a political nature except with the prior approval of the Communications Authority. *[Amended in October 2007, June 2012 and June 2016]*

11.3 Broadcasters licensed under the Broadcasting Ordinance and the Telecommunications Ordinance are required under the **fair and equal treatment principle** to handle any programmes relating to the election and candidates in compliance with the guidelines set out in this chapter and ensure that no favourable or unfavourable treatment will be given to any of the candidates/lists of candidates. *[Added in June 2016]*

11.4 For programmes of which the entire or part of the theme is on the election (e.g. for introducing the candidates/lists of candidates or reporting/analysing the election platforms and activities of the candidates/lists of candidates), the **fair and equal treatment principle** will apply. In accordance with the fair and equal treatment principle, broadcasters should ensure that each of the candidates/lists of candidates contesting in the same constituency will be introduced and reported in the programme and no favourable or unfavourable treatment will be given to any of the candidates/lists of candidates. *[Amended in June 2016]*

11.5 For current affairs or other programmes on television and radio which are not election-related, candidates/lists of candidates may take part as guests in these programmes insofar as their participation is pertinent to the subject matters of the programmes. Under the fair and equal treatment principle, broadcasters should be careful to avoid giving unfair publicity to any candidates/lists of candidates, and should be prepared to justify their choices of guests having regard to all the circumstances of the case, including the subject matter of the programmes, the candidates' background and expertise, availability of other guests having similar background and expertise, etc.

[Amended in June 2012 and June 2016]

11.6 **No unfair advantage** should be **offered** to or **obtained** by any candidate/list of candidates over others regarding election campaigning.

11.7 To comply with the fair and equal treatment principle, when inviting a candidate/list of candidates to attend a programme of which the entire or part of the theme is on the election, broadcasters should invite all candidates/lists of candidates contesting in the same constituency and include in the invitation a notice to the invitee that a similar invitation has been or will be made to other candidates/lists of candidates of the same constituency, so as to give the invitees an equal opportunity to appear. The EAC also appeals to all candidates/lists of candidates to attend these programmes as far as possible in order to enable electors and the public to be apprised of their election platforms. Some candidates/lists of candidates may choose not to attend due to personal or other reasons. Under such circumstances, the relevant broadcaster may continue with the production of the programme as planned without contravening the fair and equal treatment principle. The fair and equal treatment principle applies to the entire programme and, in particular, requires the broadcaster to give equal time to each of the candidates/lists of candidates in that part of the programme to present his/her/its election platform. **A record should be kept by the broadcaster of the date, time and contents of the invitation and the notice until 3 months after the election.** To avoid any possible confusion, broadcasters should provide the audience of the programmes with clear information on the total number and names of candidates/lists of candidates in the same constituency. Furthermore, to ensure equal treatment to all candidates/lists of candidates concerned, broadcasters should in particular take heed of the observations made by the Court in an election petition relating to the 2010 LegCo By-election as set out in **Appendix M** and, where appropriate, follow the arrangement set out therein when producing multi-episode programmes which are election-related.

[Amended in June 2012 and June 2016]

11.8 If there is evidence to substantiate that the relevant broadcaster has provided/allowed favourable or unfavourable treatment to some candidates/lists of candidates in producing the programme of which the entire or part of the theme is on the election, such case will be regarded as a breach of the fair and equal treatment principle. *[Added in June 2012]*

11.9 The principles stated in paras. 11.4 to 11.8 above apply equally to political parties or political organisations of which the candidate or candidates in a list for a GC or the DC (second) FC is/are member(s) as they apply to the candidates(s) himself/herself/themselves and to a prescribed body the registered name or registered emblem of which has been printed on any ballot papers for the election.

11.10 The aforesaid principles do not apply to programmes which are entirely news reporting and are not related to the candidates' participation in the election. Nonetheless, the broadcaster is obliged to ensure fair treatment for all candidates/lists of candidates and that no candidate/list of candidates is offered an unfair opportunity of publicity in all circumstances as required under paras. 11.4 and 11.5. *[Amended in June 2012 and June 2016]*

11.11 Broadcasters' attention is drawn to the provisions of the Generic Code of Practice on Television Programme Standards, Radio Code of Practice on Programme Standards and Radio Code of Practice on Ancillary Visual Service Standards issued by the Communications Authority which govern the accuracy, impartiality and fairness of news and current affairs programmes. *[Added in June 2016]*

11.12 During the election period (i.e. the period beginning with the commencement of the nomination for the election and ending with the polling day for the election), broadcasters should ensure that the fair and equal treatment principle is applied to all political parties or political organisations

which have members contesting the LegCo election and the said prescribed bodies, whether or not contesting the same constituency. If a political party or political organisation whose members contest as candidates in the election is invited to take part in a current affairs or any other programme of which the entire or part of the theme is on the election, then all political parties or political organisations which have members contesting the LegCo election or a prescribed body the registered name or registered emblem of which has been printed on any ballot papers for the election, whether or not contesting the same constituency, should also be invited. *[Amended in June 2012]*

11.13 The EAC appeals to broadcasters to treat all candidates/lists of candidates competing in the same constituency fairly and equally when making comments on or reference to the candidates in any of their programmes. Comments made for the purpose of promoting or prejudicing a candidate or candidates are treated as EAs, if reference could be made from the materials to identify the candidate(s) being promoted or prejudiced [see also paras. 8.3 to 8.4 of Chapter 8]. Moreover, if such comments are determined as EAs, the EAC will refer the matter to the Communications Authority for appropriate action. Where there is fair and equal treatment to all candidates/lists of candidates of the same constituency, the editorial line of the broadcaster or personal opinions of the programme presenter on each of the candidates can be freely expressed, insofar as they are fair comments and based on true facts. The guidelines do not seek to impose any shackle on the expression of such ideas. However, as election is a solemn matter, to prevent any person from having a perception that favourable or unfavourable treatment is given to any candidate(s)/list(s) of candidates, broadcasters should ensure that in the expression of such ideas, no candidate, political party or organisation to which the candidate belongs will be offered unfair publicity or advantage. *[Amended in June 2012 and June 2016]*

Candidates Appearing on Television/Radio/Movie as Presenters, Regular Contributors, Actors, Musicians, Singers or Other Entertainers

11.14 A presenter, including a guest presenter, or a regular contributor should not appear in any programme in his/her normal programme role after he/she has publicly declared his/her intention to stand for the election or during the election period if he/she becomes a candidate. This is to avoid unfair publicity for him/her at the critical time. A presenter or a regular contributor may, of course, appear as a candidate in election forums referred to in Part IV below.

11.15 A person who has contracted to appear as a presenter, regular contributor, actor, musician, singer or any other form of entertainer in any performance scheduled to be shown before his/her declaration of intention to stand for the election or before and after the election period may always do so and continue to do so. However, such a person should make his/her utmost endeavours to request the person(s) responsible not to broadcast his/her appearance in any media after his/her declaration of intention to run for the election or during the election period if he/she becomes a candidate. The EAC appeals to the aforesaid responsible person(s) to accede to such a request as far as practicable in order to avoid giving unfair publicity to the person concerned. *[Amended in June 2012]*

Candidates Appearing in Commercial Advertisements

11.16 A person should not participate in the making of an advertisement in which his/her image, name or voice appears (“the relevant advertisement”) and which he/she knows will be broadcast on television/radio/cinema after his/her declaration of intention to stand for the election or during the election period if he/she becomes a candidate.

11.17 If, after the relevant advertisement has been made, the person

then decides to run in the election, and it comes to his/her attention that the relevant advertisement will appear in television/radio/cinema after his/her declaration of intention to stand for the election or after the nomination period has commenced if he/she becomes a candidate during that period, he/she should make his/her utmost endeavours to request the person(s) responsible not to broadcast the relevant advertisement after his/her declaration of intention to stand for the election or during the election period. The EAC appeals to the aforesaid responsible person(s) to accede to such a request as far as practicable in order to avoid giving unfair publicity to the person concerned. *[Amended in June 2012]*

PART III : ADVERTISING THROUGH THE PRINT MEDIA

11.18 A candidate may advertise in the print media to promote his/her candidature. Where such an advertisement is placed in the print media and takes the form of a news report or any other form which does not clearly show that it is an EA, the words “**Election Advertisement**” or “**選舉廣告**” must be stated in the advertisement, to avoid misunderstanding by readers that it is not an EA [see para. 8.59 of Chapter 8]. The expenses so incurred must be accounted for in the election return. EAs printed in a registered local newspaper would be exempted from the requirement of bearing printing details [see also para. 8.58 of Chapter 8 for details]. The EAC appeals to all publishers to provide **equal opportunity** to all candidates/lists of candidates in the same constituency for placing advertisement in the print media. *[Amended in October 2007 and June 2016]*

11.19 The print media should ensure that, during the election period, any news reporting or reference made in its publications will not give unfair publicity to any particular candidate(s)/list(s) of candidates, or lead to a public perception that such reporting or reference is made for the publicity of a particular candidate/list of candidates. Therefore, publishers have the

responsibility to handle carefully any news reporting or reference made in relation to the election or candidate(s)/lists(s) of candidates, and ensure that no favourable or unfavourable treatment is given to any of the candidate(s)/list(s) of candidates in accordance with the **fair and equal treatment principle**. Nor should a candidate obtain from a publisher any unfair opportunity for publicity regarding election campaigning. Any publications (e.g. special newspaper editions or leaflets), whether for free or otherwise, which serve to promote or prejudice the election of a particular candidate/list of candidates may be construed as EAs for the candidate(s) concerned and are subject to the requirements for EAs and election expenses as stipulated in Chapters 8 and 16. A publisher may also contravene the relevant legislation if the requirements for publishing and distributing EAs are not complied with prior to distributing such free publication. Candidates and publishers should consult their legal advisors if they have doubt as to whether a free publication should be treated as an EA and counted towards election expenses. *[Amended in July 2008, June 2012 and June 2016]*

11.20 A regular columnist should not contribute articles to the print media after he/she has publicly declared his/her intention to stand for the election or during the election period if he/she becomes a candidate. This is to avoid unfair publicity for his/her at the critical time. A person who has contracted to serve as a columnist should make his/her utmost endeavours to request the person(s) responsible not to publish his/her commentaries in any media after his/her declaration of intention to run for the election or during the election period if he/she becomes a candidate. The EAC appeals to the aforesaid responsible person(s) to accede to such a request as far as practicable in order to avoid giving unfair publicity to the person concerned. A regular columnist may, of course, appear as candidate in election forums referred to in Part IV below. *[Amended in June 2012]*

11.21 As election is a solemn matter, the EAC appeals to members of the print media to provide **fair and equal treatment** to all candidates/lists of

candidates competing in the same constituency in the reporting of them or their electioneering activities. How fair and equal treatment is to be applied in practice is set out in **Appendix N**. In addition, when reporting candidates/lists of candidates competing in the same constituency in different pages or issues of a publication, members of the print media should provide readers with clear information on the total number and names of candidates/lists of candidates competing in the same constituency in the reports. If there is evidence to substantiate that the relevant print media has provided/allowed favourable or unfavourable treatment to a particular candidate/list of candidates in the publication, such case will be regarded as a breach of the fair and equal treatment principle and the publication is very likely to have the effect of promoting or prejudicing the election of the candidate/list of candidates concerned and thus becomes an EA of the candidate/list of candidates. The relevant acts might therefore be in breach of the statutory requirements on EAs and election expenses [see also Chapter 8 and Chapter 16] and both the print media and candidate/list of candidates concerned may as a result be subject to criminal liability. *[Amended in June 2016]*

PART IV : ELECTION FORUMS

11.22 During the election period, broadcasters may organise election forums in their programmes. Broadcasters should ensure that the fair and equal treatment principle is applied to all candidates/lists of candidates. If a candidate/list of candidates is invited to take part in the election forum, then all candidates/lists of candidates of the same constituency should also be invited to be present at such forum so as to give the candidates/lists of candidates an equal opportunity to attend the forum and present their election platforms. The fair and equal treatment principle applies to the production and conduct of the entire election forum and, in particular, requires the broadcaster to give each candidate/list of candidates in the relevant part of the election forum equal

time to present his/her/its election platform. Presenter(s) should treat each candidate/list of candidates in a courteous and fair manner at any time throughout the programme to avoid the impression that any particular candidate(s)/list(s) of candidates is/are being treated favourably or unfavourably. *[Amended in June 2012 and June 2016]*

11.23 Other organisations, such as professional or trade organisations, academic institutions and schools, etc., may organise election forums for civic education or other purposes. In line with the fair and equal treatment principle, the EAC appeals to all these organisers to invite all candidates/lists of candidates of the same constituency to be present at such forums, so that no unfair advantage will be accorded to or obtained by any candidate/list of candidates over others regarding election campaigning. *[Amended in June 2012]*

11.24 The EAC appeals to all candidates/lists of candidates to use their best endeavours to take part in election forums in order to enable electors and the public to be apprised of their platforms. Some candidates may choose not to attend due to personal or other reasons. Under such circumstances, the relevant forum organiser may continue to organise such activity as planned without contravening the fair and equal treatment principle. *[Amended in June 2012]*

PART V : SANCTION

11.25 If the EAC comes to know of unfair or unequal treatment of candidates by any broadcaster, publisher or forum organiser, it may make a **reprimand** or **censure** in a public statement which will include the names of the candidates favourably and unfavourably treated and the broadcaster, publisher or forum organiser concerned. The EAC may also notify the relevant authorities for appropriate action to be taken. Moreover, the

programme, news reporting or article concerned is very likely to have the effect of promoting or prejudicing the election of a particular candidate/list of candidates and thus becomes an EA of the candidate(s). The relevant acts might therefore be in breach of the statutory requirements on EAs and election expenses [see also Chapter 8 and Chapter 16] and both the media and candidate(s) concerned may as a result be subject to criminal liability. The EAC will refer any cases involving possible breach of the legislation to the relevant law enforcement agencies for follow-up actions. Therefore, the EAC appeals to broadcasters, publishers, forum organisers and candidates to strictly comply with the guidelines set out in this chapter and avoid any conduct which will cause public concern about the fairness of the election. *[Amended in July 2008 and June 2016]*

11.26 The candidates as mentioned in paras. 11.14 to 11.17 and 11.20 above should make their best endeavours as advised thereof to avoid taking unfair publicity. If the EAC receives a complaint about a candidate taking the aforesaid unfair publicity and it is subsequently found that the candidate has failed to make such an endeavour, the EAC may make a **reprimand** or **censure** in a public statement against the candidate. *[Added in June 2012]*

CHAPTER 12

USE OF SOUND AMPLIFYING DEVICE AND VEHICLES

PART I : GENERAL

12.1 The law relevant to this chapter can be found in the Public Order Ordinance (Cap 245), the Summary Offences Ordinance (Cap 228), the Noise Control Ordinance (Cap 400) and the Road Traffic Ordinance (Cap 374) (“RTO”).

12.2 Candidates are reminded that some members of the public find the sound or noise emitted by loudspeakers annoying and intrusive. When using loudspeakers, candidates should particularly bear in mind possible annoyance caused to people in hospitals, homes for the elderly, kindergartens, nurseries, schools and dwelling houses. Electors’ choice of candidate in casting their votes may be affected as a result of any noise nuisance caused by candidates or their supporters.

PART II : USE OF LOUDSPEAKERS AND VEHICLES

12.3 With effect from July 1995, the Commissioner of Police ceases issuing loudspeaker permits under s 4(29) of the Summary Offences Ordinance. Candidates are therefore **not** required to submit any application for a permit. However, this does not exempt candidates from complying with the requirements of the law and the conditions imposed by the Commissioner of Police when any amplification device is used in an election meeting or procession. An amplification device includes a loudspeaker and any device

which can emit or amplify sound. [Please refer to Chapter 10.]

12.4 Although no permit is now required, any person using a loudspeaker should ensure that the noise emitted through the loudspeaker does not cause a nuisance to any other person. Under s 5(1)(b) of the Noise Control Ordinance, making a nuisance by using a loudspeaker, megaphone, or other device or instrument for magnifying sound from which the noise emitted is a source of annoyance at either domestic premises or public places at any time of the day is an offence, and this includes use of loudspeakers attached to vehicles. Candidates should be mindful that some people working shift hours need to take rest during the daytime and the noise generated from the use of loudspeakers for electioneering activities may affect their daily life. In order to reduce the nuisance caused to members of the public, candidates are required **not** to use loudspeakers in electioneering **between 9 pm and 9 am**. If the EAC comes to know that a candidate/list of candidates has breached the time restriction, it may make a reprimand or censure against the candidate/list of candidates. Candidates should note that some members of the public may find the noise emitted from loudspeakers on vehicles disturbing. They should therefore seriously consider the public's tolerance over the noise level and try to keep the noise volume at a reasonable level. *[Amended in October 2007, July 2008 and June 2012]*

12.5 Should any complaint be received by the Police concerning the volume of the loudspeaker, the volume of sound should be reduced on the instructions of any police officer. If verbal warning or instruction by the police officer is ignored, prosecution may be instituted.

12.6 All vehicles used for and in connection with canvassing activities must comply with the provisions and regulations of the RTO. Drivers of such vehicles are obliged to obey all directions given by uniformed police officers and traffic wardens. Additionally, drivers of all vehicles must comply strictly with all the stopping and parking regulations of the RTO. Deliberate slow

driving may constitute “careless driving” as it could be deemed as driving “without reasonable consideration for other persons using the road”.

12.7 Paraphernalia attached to a vehicle must also comply with the Road Traffic (Construction and Maintenance of Vehicles) Regulations (Cap 374A) of the RTO, and should not affect the safe operation of the vehicle. For the display of EAs on public light buses and taxis, their owners/operators shall obtain prior written approval from the Transport Department (“TD”) and ensure that the display of EAs is in compliance with the conditions as stipulated by the TD in an approval letter, including in particular the following conditions:

- (a) (i) for taxi, no EA may be displayed on all windows;
- (ii) for public light bus, no EA may be displayed:
 - (1) on all windows except on the interior surface of:
 - the window on the left of the first row of single-seat; and
 - the window on the right of the second row of double-seat.

EA(s) to be displayed in each of the abovesaid windows shall not exceed a total size measuring 210 mm by 297 mm (equivalent to A4 size);
 - (2) at areas between the windows and the exterior roof panel; and
 - (3) on the exterior roof panel (except sticker-type EAs);
- (b) no luminous or reflecting material may be used for EAs; and

- (c) no EAs may obstruct any statutory lighting/label/markings required to be shown on the vehicle body as specified by the Commissioner for Transport or stipulated in the RTO and its subsidiary legislation.

According to the TD's performance pledge which is applicable to only public light buses and taxis, it normally takes no more than 7 working days to process an application for the display of an EA on a public light bus or taxi. The TD has issued general approval to all franchised bus companies for advertising on the body and window of buses subject to conditions imposed by the TD. The bus companies should comply with the conditions set out in the TD approval letters when they handle all kinds of advertisements. In this connection, there are no special guidelines on the display of EAs on buses. For the other modes of public transport, the operators concerned have their internal rules to govern the display of advertisements. In this regard, candidates should check with the operators for the relevant procedures and comply with the conditions imposed. *[Amended in October 2007, July 2008, June 2012 and June 2016]*

12.8 Candidates and their supporters are reminded that they should observe the statutory requirements of the Road Traffic (Safety Equipment) Regulations (Cap 374F) and Road Traffic (Traffic Control) Regulations (Cap 374G) under the RTO, including those relating to seating requirement, wearing of seat belts and permission to carry passengers in a vehicle. Standing up in moving vehicles is **illegal** for both the drivers and standees except on trams, single-decked public service buses and the lower deck of double-decked buses. Passengers can also stand up on a vehicle used as a float if approved by the Commissioner for Transport. The registered owner of the vehicle concerned should apply to the Licensing Office of the TD for exemption of the vehicles from carriage of standing passengers. *[Amended in October 2007 and June 2016]*

12.9 Any vehicle modified to a float configuration for display or

canvassing purposes must be approved by the Commissioner for Transport. Application procedures for approval of float design are included at **Appendix O**.

12.10 Candidates should also note that the use of loudspeakers will not be permitted within the NCZ outside the polling station, nor will it be permitted in the vicinity where the sound emitted can be heard within the NCZ [s 40(16) of the EAC (EP) (LC) Reg]. [See also Chapter 14.]

PART III : SANCTION

12.11 If the EAC comes to know that any candidate is in breach of the guidelines in this chapter, apart from notifying the relevant authorities for actions to be taken, it may make a **reprimand** or **censure** in a public statement which will include the name of the candidate concerned. The censure may be in addition to the criminal liability for offences inside the NCZ liable to a fine at level 2 (\$5,000) and to imprisonment for 3 months [s 45(7)(b) of the EAC (EP) (LC) Reg]. Candidates should also remind their supporters to observe these guidelines when they are campaigning on behalf of the candidates. *[Amended in October 2007 and July 2008]*

CHAPTER 13

ELECTIONEERING ACTIVITIES CONDUCTED IN SCHOOLS OR PARTICIPATED BY SCHOOL PUPILS

PART I : GENERAL

13.1 Candidates, school supervisors, principals and teachers are requested to take note of these guidelines when considering allowing the conduct of electioneering activities in their schools or seeking the assistance of pupils in electioneering activities.

13.2 Involvement of school pupils in electioneering activities has always been a matter of public concern. Anybody in authority must **not** use his/her position to exert undue influence on youths of school age under his/her charge to recruit them for electioneering activities. If the EAC comes to know that a person has abused his/her position by involving youths of school age under his/her charge in electioneering activities, it may make a reprimand or censure against the person. For use of force or duress on a person's voting preference, see s 13 of the ECICO.

PART II : SCHOOL PUPILS

13.3 While it is for the promotion of civic education that school pupils are encouraged to take an interest in community affairs, including elections, it is considered undesirable to involve them in electioneering activities at too young an age. Unattended young children may cause control problems and, particularly where in large numbers or in overcrowded situations, may create a danger to themselves and others. Therefore, pre-primary or primary school

pupils should not take part in electioneering activities. *[Amended in June 2012]*

13.4 Distribution of EAs is a form of electioneering activity. School supervisors, principals or teachers may be supporters of a particular candidate/list of candidates. While they are free to support any candidate/list of candidates they prefer, they should not distribute or help in the distribution of EAs of any candidate/list of candidates to the parents of pre-primary, primary or secondary school pupils through these pupils. Moreover, they should not ask pupils to request their parents to vote for any particular candidate/list of candidates. The guidelines above also apply to candidates who are themselves school supervisors, principals or teachers. This guideline is based on the same principle stated in para. 13.2 above, and could avoid any semblance of undue influence on young children under the charge of these persons in authority in the school. *[Amended in June 2012]*

13.5 The EAC adopts the advisory circular issued by the Secretary for Education to all schools for general guidance, emphasising the following points:

- (a) participation by pupils in electioneering activities must be **entirely voluntary**;
- (b) the **written consent** of a parent or guardian must be obtained beforehand;
- (c) in no circumstances should pre-primary or primary school pupils be asked to take part in such activities;
- (d) there should be no disruption of the pupils' education, and in no circumstances should normal lessons be interrupted to enable pupils to take part in such activities; and

- (e) in no circumstances should pupils be asked to take part in activities in areas where they may be subject to various elements of danger, including those of traffic.

[Amended in October 2007]

13.6 Pupils who take part in canvassing activities should pay attention to their own school regulations, and in particular those regarding the wearing of school uniform in such activities.

13.7 The EAC recognises that school pupils who are 18 years of age or above are by law responsible for their own acts and make election-related decisions for themselves.

PART III : ELECTIONEERING ACTIVITIES IN SCHOOLS

13.8 During the election period, school supervisors, principals or teachers may invite or be approached by candidates to give talks on topical issues to students in their schools. Regardless whether the topic to be covered by such a talk involves an election, the presence of a candidate delivering the talk and copies of the speech which may be circulated to students and brought home to their parents may have the effect of promoting or advertising that candidate/list of candidates. Such activities should, therefore, be regarded as the relevant candidate's electioneering activities. [See also para. 13.4 above.]

[Amended in June 2012]

13.9 In line with the **fair and equal treatment** principle, the EAC appeals to all school supervisors, principals and teachers to provide equal opportunity to all candidates/lists of candidates of the same constituency for the purpose of electioneering. If a school authority has decided to allow a

particular candidate/list of candidates to conduct electioneering activities in the school, other candidates/lists of candidates of the same constituency should be informed and given the opportunity to do the same, so that no unfair advantage will be accorded to or obtained by any candidate over others regarding election campaigning. Information on the name and address (and contact numbers if the candidate has no objection to releasing the same) of candidates/lists of candidates can be obtained from the REO. *[Amended in June 2012]*

PART IV : SANCTION

13.10 If the EAC comes to know that any candidate or school or person is in breach of the guidelines in this chapter, it may make a **reprimand** or **censure** in a public statement which will include the name of the candidate, the school or person concerned, and may also refer the case to the Education Bureau. Candidates should therefore apprise the school or person concerned who offers them assistance of these guidelines. *[Amended in October 2007 and July 2008]*

CHAPTER 14

PROHIBITION AGAINST CANVASSING ACTIVITIES OUTSIDE POLLING STATIONS

PART I : GENERAL

14.1 This chapter deals with the ban on canvassing activities **outside** polling stations on the polling day.

14.2 A “No Canvassing Zone Scheme” is employed for the purpose of prohibiting canvassing activities outside polling stations on the polling day in order to afford free and safe passage for electors, and to ensure that electors are not unduly harassed on their way to a polling station.

PART II : DETERMINATION OF NO CANVASSING ZONE AND NO STAYING ZONE

14.3 The RO for a GC must determine, in respect of each polling station designated for the GC and 29 FCs an area outside the polling station to be a NCZ. In so doing, he/she will take into account the characteristics and special conditions of the polling station. He/She must also determine an area within the NCZ outside the entrance/exit of the polling station as a NSZ. These 2 zones are to be determined with reference to a map or plan [s 40(1) of the EAC (EP) (LC) Reg]. *[Amended in October 2007 and June 2012]*

14.4 For a polling station which is used for more than one constituency, the determination of the NCZ and NSZ is to be made by the RO specified for the purpose by the CEO [s 40(2) of the EAC (EP) (LC) Reg]. *[Added in June*

2012]

14.5 The RO who made the determination of a NCZ and a NSZ in respect of a polling station must, at least **7 days** before the polling day, give a notice of the determination to the candidates of his/her own constituency and, where appropriate, to the ROs of other constituencies for which polling will be held in the polling station; and thereafter each of the ROs of these other relevant constituencies must give the notice of the determination to the candidates of his/her own constituency as soon as practicable [s 40(3), (4), (6), (7) and (8) of the EAC (EP) (LC) Reg].

14.6 The notice will be given in writing, and delivered by hand, by post, by electronic mail or by facsimile transmission, to the candidates/lists of candidates (or in the case of a multiple candidates list, to the candidate ranking first in priority on the list) or to the election agents or to the polling agents of the candidates/lists of candidates [s 40(3), (4), (6) and (14) and s 98(2) of the EAC (EP) (LC) Reg]. *[Amended in October 2007, July 2008, June 2012 and June 2016]*

14.7 Where the circumstances so warrant, the RO who has made a determination may vary the NCZ or NSZ. Notice of the variation must be given as soon as practicable after the variation in the same manner as a notice referred to in para. 14.6 above. [S 40(9) of the EAC (EP) (LC) Reg] The notice of variation of a NCZ or NSZ on the polling day may be given orally if sending it by hand, by post, by electronic mail or by facsimile transmission is not practicable or is not suitable in the circumstances [s 98(3) of the EAC (EP) (LC) Reg]. However, a notice of variation need not be given to the candidates if it is not reasonably practicable to do so before the close of poll [s 40(13) of the EAC (EP) (LC) Reg]. *[Amended in June 2012 and June 2016]*

14.8 A notice of the determination or the variation, together with indication of the boundaries of the NCZ or the NSZ, must be displayed on the

polling day at or near the relevant polling station, in order to make the determination or variation effective [s 40(10), (11) and (12) of the EAC (EP) (LC) Reg].

14.9 The RO who is empowered to determine NCZ and NSZ may authorise his/her ARO or the PRO of the relevant polling station to exercise the power to vary the determination and to perform the associated duties on the polling day [ss 40(11A) and 92 of the EAC (EP) (LC) Reg]. *[Amended in July 2008]*

PART III : CONDUCT INSIDE THE NO CANVASSING ZONE AND NO STAYING ZONE

14.10 Door-to-door canvassing and for the purpose of such canvassing, the display or wearing of propaganda material, e.g. any badge, emblem, clothing or head-dress which may promote or prejudice the election of a candidate or candidates at the election, or makes direct reference to a body any member of which is standing as a candidate in the election or to a prescribed body the registered name or registered emblem of which has been printed on any ballot paper for the election, will be allowed on the storeys above or below street level in a building within a NCZ other than a building in which there is a polling station provided that permission has been obtained for entry to the building for canvassing votes, and that obstruction is not posed to electors and no sound amplifying device is used (except for the performance of duties by officers of the CSD on the polling day at the dedicated polling stations situated in prisons) [s 40(16), (17), (18) and (19) of the EAC (EP) (LC) Reg]. Apart from this, no other canvassing activities (including suggesting not to vote for any candidate) will be allowed within a NCZ except for static display of EAs mounted at designated spots approved by the RO. Where there are premises situated within the NCZ, the ROs should issue a notice in advance to all the candidates in the constituencies concerned asking them to remove all of their

EAs, if any, posted up at the premises within the NCZ which can be seen by the electors on their way to the polling stations on the polling day. If the candidates fail to remove the EAs as requested by the ROs, the ROs may issue a warning to them to remove the offending EAs immediately. If the candidate/list of candidates fails to do so, the EAC may issue a censure or reprimand. Canvassing activities may take many different forms. A list of common canvassing activities which are forbidden in a NCZ is at **Appendix G**. *[Amended in October 2007, June 2012 and June 2016]*

14.11 On the polling day, the PRO will use his/her best endeavours to ensure that no person carries out any activity other than those permitted activities described in para. 14.10 above in the NCZ in respect of his/her polling station to persuade or induce any elector to vote or not to vote [s 41(1) of the EAC (EP) (LC) Reg]. Any unauthorised display of EAs in the area will be removed by the RO or other persons authorised by the RO [s 107 of the EAC (EP) (LC) Reg]; and any person found to have conducted canvassing activities prohibited in the area will be asked to leave the area [s 41(2) of the EAC (EP) (LC) Reg]. *[Amended in October 2007]*

14.12 The use of loudspeakers or loud-hailers will not be permitted within the NCZ, nor will any such device or any activity (e.g. lion dance) be permitted in the vicinity so that the sound emitted can be heard within the NCZ [ss 40(16) and 41(1) of the EAC (EP) (LC) Reg]. However, an officer of the CSD may on the polling day use a sound amplifying system or device for the performance of his/her duties in the NCZ of a dedicated polling station situated in a prison [ss 40(19) and 41(1A) of the EAC (EP) (LC) Reg]. Save for canvassing activities allowed in para. 14.10, candidates and their supporters are not allowed to pass, let alone shout, appeal message to persons while inside the NCZ. [See Part II of Chapter 12 regarding the use of loudspeakers.] *[Amended in June 2012]*

14.13 Within the NCZ but immediately outside the entrance/exit of each

polling station (and sometimes the entrance is also the same as the exit), there will be a **NSZ**, in which no person is allowed to stay or loiter, except where a person has been expressly permitted to do so by the PRO [ss 40(16) and 41(1)(d) of the EAC (EP) (LC) Reg]. This is for the purpose of securing safe and smooth passage of electors into and out of polling stations. *[Amended in October 2007]*

14.14 A person shall not obtain or attempt to obtain (in any manner) information as to which candidate an elector of the relevant polling station is about to vote for or has voted for in a NCZ or in a NSZ without the express permission of the PRO who should have regard to exit pollsters who have complied with the requirements set out in Chapter 15. [S 96(7) of the EAC (EP) (LC) Reg]

14.15 Any person who misconducts himself/herself or carries out any forbidden activity in a NCZ or NSZ, or fails to obey a lawful order of the RO (who has made the determination in respect of that NCZ or NSZ) or the PRO, commits an offence and will be liable to a fine and to imprisonment and may be ordered by such officer to leave the NCZ or NSZ [ss 41(2), 45(4) and (7)(b) of the EAC (EP) (LC) Reg]. If he/she fails to leave immediately, he/she may be removed from the relevant zone by a police officer, an officer of the CSD or any law enforcement agency, or by any other person authorised in writing by the RO or the PRO [s 41(3) of the EAC (EP) (LC) Reg]. The person so removed may not re-enter the NCZ or NSZ on that day except with the permission of the RO or the PRO [s 41(4) of the EAC (EP) (LC) Reg]. *[Amended in October 2007 and January 2010]*

14.16 Nevertheless, the RO or the PRO shall not exercise their powers to remove an elector from the NCZ or NSZ so as to prevent him/her from voting [ss 41(5), 44(14) and 46(5) of the EAC (EP) (LC) Reg].

PART IV : PENALTY

14.17 Any canvassing within a NCZ except those exempted and any conduct prohibited under paras. 14.13 and 14.15 above will each be an offence under s 45(7)(b) of the EAC (EP) (LC) Reg and will be liable to a fine at level 2 (\$5,000) and to imprisonment for 3 months. Any attempt to obtain information as described in para. 14.14 above without the necessary permission will be an offence under s 96(10) of the EAC (EP) (LC) Reg and will be liable to a fine at level 2 (\$5,000) and to imprisonment for 6 months. *[Amended in October 2007]*

CHAPTER 15

EXIT POLL

PART I : GENERAL

15.1 This chapter sets out the guidelines for the conduct, publication and broadcast of exit polls to avoid unfair interference with the election process by unduly influencing electors. The aim is to ensure that elections are conducted honestly and fairly and, at the same time, to strike a good balance between the need to maintain order outside polling stations and upholding the freedom of expression, freedom of the press and academic freedom. *[Amended in June 2012]*

15.2 **The EAC appeals to the media and organisations concerned for self-regulation, goodwill and voluntary cooperation in the conduct of exit polls, and the publication and broadcast of the result of exit polls so that electors' behaviour will not be unduly affected.**

PART II : SECRECY OF THE VOTE

15.3 **The ballot is secret.** It is an elector's right to keep his/her vote secret. An elector does not have to disclose his/her choice of candidate/list of candidates if he/she does not want to. **It is a criminal offence for a person, without lawful authority, to require, or purport to require, an elector/AR to disclose the name of, or any particular relating to, the candidate/list of candidates for whom the elector/AR has voted at an election** [s 60 of the LCO and s 96(7) of the EAC (EP) (LC) Reg]. **Those who conduct exit polls must respect the electors' right and wish not to be disturbed.** The

interviewers should inform the electors being interviewed that their participation in the exit poll is voluntary prior to the conduct of exit poll. *[Amended in October 2007, July 2008 and June 2012]*

15.4 Any announcement or disclosure of results of exit polls or predictions, particularly in relation to any individual candidate/list of candidates, during the polling hours may affect electors' behaviour and have an impact on election results. **The EAC, therefore, reminds the media and organisations concerned that they should not announce the results of exit polls or make specific remarks or predictions on the performance of individual candidate/list of candidates before the close of poll. Furthermore, interviewers of approved exit poll should not speak to or communicate with candidates/lists of candidates or their agents when conducting the poll outside polling stations.** *[Amended in July 2008, June 2012 and June 2016]*

PART III : CONDUCT OF EXIT POLLS

15.5 Any person or organisation may apply to the REO to conduct exit polls in respect of any GC/FC. However, to forestall public perception of unfairness, approval would normally not be granted in one or more of the following circumstances:

- (a) the applicant has publicly expressed support for any candidate(s)/list(s) of candidates contesting in the constituency, of which any polling stations are covered by the exit poll(s);
- (b) the applicant organisation has member(s) contesting in the constituency, of which any polling stations are covered by the exit poll(s);

- (c) the person(s) responsible for the exit poll(s) or interviewers nominated for the poll(s) are currently members of the organisation(s) -
 - (i) which has candidate(s) contesting in the constituency, of which any polling stations are covered by the exit poll(s),
or
 - (ii) which have publicly expressed support for any candidate(s)/list(s) of candidates contesting in the constituency, of which any polling stations are covered by the exit poll(s).

[Amended in June 2012 and June 2016]

15.6 For security reasons, no exit poll may be conducted for dedicated polling stations. For the purpose of better control of the conduct of exit poll, persons or organisations intending to conduct exit polls must provide the following to the REO **at the latest 10 days before the polling day**:

- (a) the name and address of the person or organisation intending to conduct an exit poll on the polling day;
- (b) the identity document number and name of the person responsible together with his/her telephone number(s) for contact, especially during the polling hours; and
- (c) a list showing the number of persons who will be deployed for the conduct of the exit poll at each polling station on the polling day together with the identity document number and name of each of all the persons who will be so deployed.

[Amended in July 2008, January 2010 and June 2012]

15.7 On the receipt of the application, the REO will consider the application and issue approval to the person or organisation concerned as appropriate. Before the grant of approval, the person or organisation allowed to conduct exit poll will be required to sign a **declaration** to abide by its terms and the guidelines governing the conduct of exit poll. If a person or an organisation fails to comply with the terms of the declaration and the guidelines set out in this chapter, the approval to conduct exit poll on the polling day or during the polling hours may be revoked. The EAC may also make a reprimand or censure in a public statement which will include the name of the person or organisation who/which fails to comply with the terms of the declaration and the guidelines. A notice showing the persons or organisations allowed to conduct exit poll together with their contact telephone numbers will be released to the public prior to the polling day for the reference of the public and candidates. Such a notice will also be displayed at the respective polling stations. *[Amended in July 2008, June 2012 and June 2016]*

15.8 Interviews are not allowed inside polling stations. Interviewers should note that canvassing activity is prohibited under criminal sanction within the NCZ except door-to-door canvassing activities on the storeys above or below street level in a building other than the one in which there is a polling station provided that permission has been obtained for entry to the building for canvassing votes, and that obstruction is not posed to electors and no sound amplifying device is used. Interviewers must therefore be extremely careful in conducting exit poll so as not to give rise to any suspicion that they are canvassing electors inside the NCZ. Interviewers, like any other person, are not allowed to stay or loiter in the areas designated as the NSZ (within the NCZ but immediately outside the entrance/exit to each polling station). [S 41(1) of the EAC (EP) (LC) Reg] Interviewers are also not allowed to accost electors in the NSZ. All these measures are for the purpose of securing safe and smooth passage of electors into and out of polling stations. The PRO of a

polling station may, if circumstances require, designate an area outside the exit of the polling station so that interviewers may only conduct exit poll within that area. *[Amended in October 2007]*

PART IV : IDENTIFICATION OF INTERVIEWERS

15.9 There had been occasions where exit poll interviewers were mistaken for government officials or polling staff. Such interviewers are therefore required to display prominently an identification device showing the identity of the organisation/person conducting exit poll so that electors will not be misled into thinking that they are appointed by the Government. In addition, the interviewers are required to make known to the electors that any response is entirely voluntary. Arrangements should be made for electors to be aware of the name of the organisation/person conducting the exit poll at the start of the interview and the fact that the exit poll is not commissioned by the Government. *[Amended in July 2008 and June 2016]*

15.10 After receipt of the information referred to in para. 15.6 above, the REO will notify the organisation or person concerned to collect a number of identification devices bearing the name of the organisation/person that is required to be displayed prominently by each of the persons included in the list in para. 15.6(c) above when conducting an exit poll. Any person not displaying prominently such a device will not be allowed to conduct an exit poll outside any polling station. *[Amended in July 2008]*

PART V : SANCTION

15.11 Apart from the criminal sanction provided in the LCO, if the EAC comes to know that any broadcaster or organisation has failed to heed or comply with the guidelines in this chapter, it may make a **reprimand** or

censure in a public statement which will include the name of the broadcaster or the organisation concerned. *[Amended in July 2008]*

CHAPTER 16

ELECTION EXPENSES AND ELECTION DONATIONS

PART I : WHAT CONSTITUTES ELECTION EXPENSES

16.1 Provisions relating to election expenses can be found in the ECICO.

16.2 **Election expenses**, in relation to a candidate/list of candidates at an election, mean expenses incurred or to be incurred **before, during** or **after** an **election**, by or on behalf of a candidate/list of candidates for the purpose of promoting the election of the candidate/list of candidates, or prejudicing the election of another candidate/list of candidates, and include the value of election donations consisting of goods and services used for that purpose [s 2 of the ECICO]. The term “candidate” includes a person **who has publicly declared an intention to stand for election** in respect of a constituency at any time before the end of the nomination period for the election, regardless of whether he/she has submitted his/her nomination form, or after submission of the nomination form, he/she has withdrawn his/her nomination, or his/her nomination is ruled invalid by the RO [s 2 of the ECICO]. A prescribed person who has applied under PCBP (LC & DC) Reg to have his/her emblem registered should not, by that act alone, be treated as having publicly declared an intention to stand for election. As the list voting system of proportional representation applies to the election of the GCs and the DC (second) FC, where lists of candidates instead of individual candidates will contest the election, a candidate who is on a list of candidates should pay attention to the special features applicable to the GC and DC (second) FC lists as set out in Part VII, although the law and guidelines in this chapter referable to candidates apply generally to the GC and DC (second) FC lists of candidates. *[Amended*

in October 2007 and June 2012]

16.3 When considering what expenses would amount to “election expenses” under the law in different circumstances, it is considered both necessary and useful to take heed of the observations made by the CFA in a case relating to the 2008 LegCo Election, as summarised in **Appendix P**.
[Added in June 2012]

16.4 A candidate may receive **election donations** for the purpose of meeting the costs of his/her election expenses. Election donation, in relation to a candidate or candidates at an election, means any of the following donations:

- (a) any money given to or in respect of the candidate or candidates for the purpose of meeting or contributing towards meeting the election expenses; or
- (b) any goods given to or in respect of the candidate or candidates for the purpose of promoting his/her/their election or of prejudicing the election of another candidate or other candidates and includes any goods given incidental to the provision of voluntary service; or
- (c) any service provided to or in respect of the candidate or candidates for the purpose of promoting his/her/their election or of prejudicing the election of another candidate or other candidates, but does not include voluntary service.

[S 2 of the ECICO]

An election donation to a candidate on a list of candidates will necessarily be a donation to all the individual candidates on the list jointly [see Part VII of this

chapter]. All such donations, whether in cash or in kind, when spent or used, are counted as election expenses. [For details, see Part III of this chapter.]
[Amended in June 2012]

16.5 It is a question of fact in each case whether expenses incurred will or will not be counted as election expenses. For as long as an expense is incurred for the purpose either of:

- (a) promoting the election of a candidate; or
- (b) prejudicing the election of another candidate or other candidates;

it will be an election expense, irrespective of when it is incurred, either before, during or after the election, and regardless of the source of funding.
[Amended in June 2012]

16.6 Whether a particular item of expenditure should be regarded as an election expense is a question of fact to be answered in the circumstances of each case. Each case should be determined by reference to the purpose behind the expenses, taking account of the nature, circumstances and context of the expenditure. If an expense is incurred for more than one purpose, there is a need for apportionment of expenses between election-related purposes and any other purposes. The candidate/list of candidates concerned should include relevant particulars in his/her/their election return. As a general principle, time and usage are relevant factors for consideration. The candidate/list of candidates may seek professional advice on apportionment of expenses as necessary. Any fees incurred for such professional advice will not be regarded as his/her/their election expenses. *[Amended in June 2016]*

16.7 Use of staff and other resources which are available to a candidate in his/her official capacity or at work for the purpose of promoting his/her candidature in the election should be counted as election expenses. A

list of common expenditure items which may be counted towards election expenses is at **Appendix Q**. The list is only illustrative and should not be considered as having precedence over the legislation. Candidates should consult their legal advisers if they have doubt as to whether an expenditure item should count as an election expense. Any legal fees incurred as a result will not themselves be regarded as election expenses.

16.8 A candidate should not use any public resource for the purpose of promoting his/her election or prejudicing the election of another candidate or other candidates at the election. *[Amended in June 2016]*

PART II : WHO MAY INCUR ELECTION EXPENSES AND THEIR LIMIT

Maximum Amount of Election Expenses

16.9 The maximum amount of election expenses for the LegCo election for the different constituencies is prescribed by the Maximum Amount of Election Expenses (Legislative Council Election) Regulation (Cap 554D) made by the CE in Council pursuant to s 45 of the ECICO. These expense limits control the extent of election campaigns and serve to prevent candidates with ample financial resources from having an unfair advantage. *[Amended in October 2007, July 2008, June 2012 and June 2016]*

16.10 The election expense limits (from the 2016 LegCo general election onwards) are set out in the following table. For ascertaining the number of registered electors referred to in items (c), (d) and (e), inquiry can be made with the RO for the constituency concerned.

Constituencies	Election Expense Limits
<p>(a) for a GC election:</p> <p>(i) Hong Kong Island GC</p> <p>(ii) Kowloon East and Kowloon West GCs</p> <p>(iii) New Territories East and New Territories West GCs</p>	<p>\$2,428,000 per list of candidates</p> <p>\$1,821,000 per list of candidates</p> <p>\$3,035,000 per list of candidates</p>
<p>(b) for an election for one of the following 4 SFCs, namely Heung Yee Kuk, Agriculture and Fisheries, Insurance, and Transport FCs</p>	<p>\$121,000 per candidate</p>
<p>(c) for an election for a FC (other than those in (b) above and the DC (second) FC) with not more than 5,000 registered electors</p>	<p>\$194,000 per candidate</p>
<p>(d) for an election for a FC (other than the DC (second) FC) with between 5,001 and 10,000 registered electors</p>	<p>\$388,000 per candidate</p>
<p>(e) for an election for a FC (other than the DC (second) FC) with over 10,000 registered electors</p>	<p>\$583,000 per candidate</p>
<p>(f) for a DC (second) FC election</p>	<p>\$6,936,000 per list of candidates</p>

[Ss 3, 3A and 4 of the Maximum Amount of the Election Expenses (Legislative Council Election) Regulation] *[Amended in July 2008, June 2012 and June 2016]*

16.11 A candidate must not incur election expenses in excess of the maximum amount prescribed [s 24(1) of the ECICO]. For lists of candidates at an election at which the list system of voting is used, each member of a list of candidates engages in illegal conduct at the election if the aggregate amount of the election expenses incurred at or in connection with the election by or on behalf of the list exceeds the prescribed maximum amount of election expenses [s 24(2) of the ECICO]. *[Amended in June 2012 and June 2016]*

Persons Authorised to Incur Election Expenses

16.12 Only a candidate or a person (including a fellow candidate on the same list of candidates) who has been duly authorised by a candidate as the candidate's election expense agent may incur election expenses [s 23(1) and (2) of the ECICO]. The authorisation should follow the procedures specified in Part VI of Chapter 7. *[Amended in June 2012]*

16.13 Before incurring expenses in carrying out any **negative campaigning (i.e. canvassing against other candidates/lists of candidates)** for or for the benefit of a candidate, a person will need the authorisation of the candidate to be the election expense agent of the candidate. Such expenses will be counted towards election expenses of the candidate. If the negative campaign includes EAs, all the requirements of the ECICO and of the EAC (EP) (LC) Reg must also be complied with. *[Amended in October 2007 and June 2012]*

16.14 Candidates should advise the organisations with which they are associated and which may incur expenses to support them of these guidelines

as soon as they have any intention or plan to run for an election, to avoid offences being committed by these organisations out of ignorance.

16.15 A candidate will be responsible for the overall amount of his/her election expenses. In the event the total amount incurred by him/her and/or on his/her behalf exceeds the limit prescribed, he/she will be liable for contravening the law, unless he/she can prove that the excess was incurred without his/her consent, or beyond his/her authorisation, and not due to any negligence on his/her part. The election expense agent, on the other hand, should not incur an amount of election expenses which exceeds the limit authorised by the candidate lest the agent will contravene s 23(4) of the ECICO. [Ss 23 and 24 of the ECICO] *[Amended in June 2012]*

PART III : ELECTION DONATIONS

General Provisions

16.16 A person who has made known his/her intention to stand as a candidate in an election may receive election donations for the sole purpose of meeting his/her election expenses.

16.17 Election donations can only be used for meeting, or contributing towards meeting, a candidate's election expenses, or in the case of an election donation consisting of goods or services, for the purpose of promoting the election of the candidate or of prejudicing the election of another candidate or other candidates [s 18 of the ECICO].

16.18 Election donations can be in cash or in kind, and include any money's worth, any valuable security or other equivalent of money and any valuable consideration. Election donations in kind include goods and services obtained free of charge or at a discount. All spent or used election donations,

whether in cash or in kind, which may be received before, during or after an election, are counted towards the total election expenses which are subject to the maximum amount prescribed. *[Amended in June 2016]*

16.19 Any unspent or unused election donations must be given to charitable institution(s) or trust(s) of a public character chosen by the candidate(s). Any amount of election donations that exceeds the upper limit of election expenses must also be given to such charitable institution(s) or trust(s). It must be done before the election return is lodged in accordance with s 37 of the ECICO. [S 19(4) of the ECICO] *[Amended in June 2012]*

16.20 Since election donations can only be lawfully spent for meeting or contributing towards meeting election expenses, donations and expenses are often corresponding to each other. For every item of election expense which is avoided or reduced by obtaining the goods supplied or services rendered free of charge or at a discount, there should normally be a corresponding item of election donation. The only exception is voluntary services obtained that are not treated as election donations (but any goods given incidental to the provision of a voluntary service will however be counted as an election donation). These points are elaborated in paras. 16.23 to 16.25 below. *[Amended in June 2012]*

16.21 On receiving an election donation, of money or in kind, of more than \$1,000 in value, a candidate must issue to the donor a receipt which specifies the name and address of the donor (as supplied by the donor) as well as the particulars of the donation. A standard form of receipt is obtainable from the REO and will be provided to a candidate/list of candidates when he/she/they submit(s) the nomination form. While it is not uncommon that some donors would like to be anonymous, if a donation, in cash or in kind, is more than \$1,000 in value, then only where the donor's name and address (as supplied by the donor) are shown as required by the standard form of donation receipt can it be used for election-related purpose. Donations exceeding

\$1,000 or, in the case of an election donation consisting of goods, of more than \$1,000 in value received from anonymous donors must not be used for meeting election expenses and must be given to a charitable institution or trust of a public character chosen by the candidate(s) [s 19(1) and (2) of the ECICO].
[Amended in October 2007, June 2012 and June 2016]

16.22 Any person or organisation (including a political party) acting as an agent to solicit, receive or collect election donations for a candidate or some candidates should also comply with all the requirements under the ECICO as if the election donations are received by the candidate(s) direct. To avoid possible confusion to donors/members of the public, the agent is advised to note the points and adopt the good practice suggested in **Appendix R**.
[Added in June 2016]

Election Donations in Kind

16.23 Election donations in kind include goods and services obtained free of charge or at a discount. Unless the discount is generally available to all customers, the difference between the market/regular price and the price charged is an election donation and must be declared and included as such and correspondingly as an election expense in the election return. The same principle applies to loans obtained at no interest or at an interest rate lower than usual. Unless the facility is generally available to others, the interest not charged must be declared and included as an election donation and election expense in the election return. For premises provided free of charge to a candidate for his/her election campaign, a reasonable amount should be assessed as the deemed rental for the premises, declared and included as an election donation and election expense in the election return.

16.24 For services or goods obtained free of charge, a candidate must include in the election return their estimated value as if the expenses had been incurred. Where the services or goods are furnished by a person who deals in

similar services or goods with the public, their estimated value should be assessed at the lowest price at which the person offers his/her services or goods to the public at the time when they are furnished. Where such services or goods are furnished by persons who do not deal in similar services or goods with the public, their estimated value should be assessed at the lowest market retail price at the time when they are furnished.

16.25 **Voluntary service** is the only service rendered free of charge which may be excluded from being counted as election expenses. In addition to being free of charge, the service must be provided by a natural person, voluntarily and personally, in his/her own time for the purpose of promoting the election of the candidate or candidates, or of prejudicing the election of another candidate or other candidates [s 2 of the ECICO]. Otherwise, the service provided should be treated as an election donation and counted towards election expenses at a fair estimated value. *[Amended in October 2007]*

PART IV : RETURN AND DECLARATION OF ELECTION EXPENSES AND ELECTION DONATIONS

16.26 A candidate must keep an accurate account of all election expenses incurred and election donations (whether in cash or in kind) received, and submit to **the CEO an election return in a specified form before the expiry of the period of 60 days after the date on which the last of the following events occurs in relation to the election –**

- (a) **the result of the election is notified in the Gazette;**
- (b) **the proceedings for the election are declared to have been terminated;**
- (c) **the election is declared to have failed,**

or within such extended period as may be allowed by the CFI under the relevant law [s 37(1), (1B), (1C) and (1N) of the ECICO]. *[Amended in October 2007, June 2012 and June 2016]*

16.27 The election return must cover all the election expenses incurred by the candidate or the person(s) so authorised by him/her, services or goods obtained free of charge or at a discount and all outstanding claims. It must be submitted with supporting invoices and receipts issued by recipients of the payments for all payments each of \$100 and above. The copies of receipts issued by the candidate for election donations of more than \$1,000 in value and those issued by charitable institutions or trusts of a public character for the collection of any unspent election donations, anonymous donations of more than \$1,000 in value or election donations which are in excess of the limit of election expenses must also be attached. A declaration verifying the contents of the election return must also be submitted together with the election return. [S 37 of the ECICO] *[Amended in June 2012 and June 2016]*

16.28 At the time when a candidate/list of candidates submits his/her/their nomination form, he/she/they will be given:

- (a) the specified form for making election return mentioned in para. 16.26 above, together with a standard form of receipt for election donations mentioned in para. 16.21 above;
- (b) the standard form for advance return of election donations [see paras. 16.35 to 16.37 below]; and
- (c) a guide and a video showing how the election return can be completed.

A candidate should read the explanatory notes attached to the election return

carefully before completing it, and make reference to the guide and video whenever necessary. *[Amended in June 2016]*

Statutory Relief Mechanism for Errors and False Statements

16.29 If a candidate is unable or fails to send to the CEO the election return before the end of the permitted period due to his/her own illness or absence from Hong Kong, or the death, illness, absence from Hong Kong or misconduct of any agent or employee of the candidate, or by reason of inadvertence or accidental miscalculation by the candidate or any other person, or any reasonable cause, and not due to the candidate's bad faith, he/she can make an application to the CFI for an order to allow him/her to send in the election return within a further period as specified by the CFI [s 40(1) and (2) of the ECICO]. The legal costs so incurred will not be regarded as his/her election expenses. *[Amended in June 2012 and June 2016]*

16.30 If a candidate makes an error or a false statement in the election return due to misconduct of any agent or employee of the candidate, or by reason of inadvertence or accidental miscalculation by the candidate or any other person, or any reasonable cause, and not due to the candidate's bad faith, he/she may apply to the CFI for an order to enable him/her to correct any error or false statement in the election return or in any document accompanying the election return [s 40(3) and (4) of the ECICO]. The legal costs so incurred will not be regarded as his/her election expenses. *[Added in June 2012 and amended in June 2016]*

16.31 Notwithstanding the provision set out in para. 16.30 above, if a candidate makes any error and/or false statement in the election return, the nature of which is either a failure to set out in the election return any election expense of the candidate at the election or any election donation received by or on behalf of the candidate in connection with the election, or incorrectness in the amount of any election expense or any election donation, **and** the aggregate

value of the error(s) and/or false statement(s) does **not** exceed, as the case may be:

- (a) \$3,000 for an election to elect a Member or Members of the GC;
- (b) \$5,000 for an election to elect a Member or Members of the DC (second) FC;
- (c) \$500 for an election to elect a Member or Members of any FC other than the DC (second) FC;

[Items (2), (3) and (4) of the Schedule of the ECICO]

he/she may, subject to the conditions set out in para. 16.32 below, seek to have the error and/or false statement rectified in accordance with a simplified relief arrangement for minor errors or false statements as provided under s 37A of the ECICO. Under the arrangement, the candidate may write to notify the CEO of his/her request for lodging a revised election return to rectify the error and/or false statement and provide the necessary details for consideration of the request. If the CEO is satisfied that it is appropriate to allow the candidate to lodge a revised election return under the simplified relief arrangement, the CEO would issue a notice to the candidate. Upon receipt of the notice, the candidate may, within the specified period, lodge with the CEO a revised election return which will be a copy of the original election return earlier submitted to the CEO marked with the necessary revision to have the error(s) or false statement(s) in question corrected. An error or false statement made in an election return also includes an error or false statement in any document accompanying the election return; or a failure to send any document required by s 37(2)(b) of the ECICO in relation to the election return [s 37A(12) of the ECICO]. *[Added in June 2012 and amended in June 2016]*

16.32 A copy of the revised election return lodged by a candidate is of

no effect unless it is:

- (a) lodged within 30 days after the date on which the candidate receives a notice from the CEO relating to the error(s) and/or false statement(s) in the election return;
- (b) accompanied by all relevant documents as required under s 37(2)(b) of the ECICO (e.g. invoice and receipt) and, if applicable, an explanation; and
- (c) accompanied by a declaration to be made by the candidate in a specified form verifying the contents of the revised election return.

[s 37A(6) of the ECICO]

A copy of the revised election return made under the relief arrangement cannot be withdrawn or further amended after it has been lodged with the CEO. If the candidate fails to correct the error(s) or false statement(s) within the specified period, the election return will be subject to the normal checking and investigation under the ECICO. *[Added in June 2012 and amended in June 2016]*

16.33 The relief arrangement will not be applicable if, after including the cumulative amount of errors or false statements, the aggregate amount of election expenses incurred at or in connection with the election, exceeds the maximum amount of election expenses prescribed for a candidate, which is an illegal conduct under s 24 of the ECICO. If the ICAC has received complaints or information indicating that a candidate may have made a statement that he/she knows or ought to know is materially false or misleading which amounts to corrupt conduct under s 20 of the ECICO, the ICAC will conduct investigation into the case despite the relief arrangement set out above.

The rectifications of the election return under the relief arrangement will not exempt the candidate from being investigated or subsequently prosecuted under the ECICO in such circumstances. Moreover, this relief arrangement will not relieve the candidate from liability under other offence provisions in the ECICO if the election return concerned has contravened any such provisions. [S 37A of the ECICO] *[Added in June 2012]*

16.34 When the candidate finds himself/herself in any of the situations set out in paras. 16.29 and 16.30 above, other than the situations where correction of errors or false statements is allowed under the relief arrangement in para. 16.31, it would be wise of him/her to make the application to the CFI and inform the REO as soon as possible. The legal costs so incurred will not be regarded as his/her election expenses. It is a corrupt conduct if a candidate who, in an election return lodged under s 37 of the ECICO, or a copy of an election return lodged under s 37A of the ECICO, makes a statement that he/she knows or ought to know is materially false or misleading [s 20 of the ECICO]. *[Amended in October 2007 and June 2012]*

PART V : ADVANCE RETURN OF ELECTION DONATIONS

16.35 Any candidate who is an incumbent public servant under the POBO, e.g. a serving member of the LegCo or a DC, etc., may give advance disclosure to the CEO of any election donations received. This may enable such an incumbent member to avoid any inadvertent contravention of the provisions of the POBO relating to the acceptance of “advantages”. The donations so disclosed must also be incorporated in the election return to be submitted to the CEO before the expiry of the period, or extended period provided for in s 37 of the ECICO for lodging an election return [see para. 16.26 above] [ss 37(1), (1B) and (1C) of the ECICO]. The general provisions regarding election donations in Part III must be observed. *[Amended in October 2007, June 2012 and June 2016]*

16.36 Any **advance return of election donations** must be made on the standard form mentioned in para. 16.28 above. *[Amended in June 2012]*

16.37 Depending on the time and the number of election donations received, a candidate may submit any number of advance returns of election donations to the CEO. *[Amended in June 2012]*

PART VI : FINANCIAL ASSISTANCE

16.38 Under the Financial Assistance Scheme for candidates and lists of candidates standing in LegCo elections in respect of election expenses, candidates/lists of candidates who get elected or who have received 5% of valid votes or more and are not disqualified will be eligible for financial assistance as follows:

- (a) in respect of a candidate/list of candidates in a contested GC or FC, the amount payable is the lowest of the following:
 - (i) the amount obtained by multiplying the total number of valid votes cast for the candidate/list of candidates by the specified rate (at \$14 per vote, from the 2016 LegCo general election onwards); *[Amended in July 2008, June 2012 and June 2016]*
 - (ii) 50% of the maximum amount of election expenses that may be incurred by or on behalf of the candidate/list of candidates as set out in ss 3, 3A or 4 of the Maximum Amount of Election Expenses (Legislative Council Election) Regulation; or *[Added in June 2012]*

- (iii) the declared election expenses of the candidate/list of candidates.
- (b) in respect of a candidate/list of candidates in an uncontested GC or FC, the amount payable is the lowest of the following:
- (i) the amount obtained by multiplying 50% of the number of registered electors for the constituency by the specified rate (at \$14 per registered elector, from the 2016 LegCo general election onwards); *[Amended in July 2008, June 2012 and June 2016]*
 - (ii) 50% of the maximum amount of election expenses that may be incurred by or on behalf of the candidate/list of candidates as set out in ss 3, 3A or 4 of the Maximum Amount of Election Expenses (Legislative Council Election) Regulation; or *[Added in June 2012]*
 - (iii) the declared election expenses of the candidate/list of candidates.

[Ss 60D, 60E and Schedule 5 of the LCO]

The amount of election donations received by a candidate/list of candidates will not affect the calculation of the amount of financial assistance payable to the candidate/list of candidates. As election donations will not be netted off in calculating the amount of financial assistance payable to a candidate/list of candidates, the amount of financial assistance payable to a candidate/list of candidates in some cases may be greater than the amount of his/her or their net election expenses¹⁵. Any such ‘surplus’ financial assistance may be used by

¹⁵ This may occur if the candidate/list of candidates secures donations which exceed 50% of his/her/their total election expenses.

the candidates for their future political or community work, or it may be expended generally as a token recognition of their efforts in election. The broad procedural and documentary requirements for making a claim, and general conditions for payment to be made are provided in Part 6A of the LCO. The EAC (FA) (APP) Reg sets out the detailed implementation procedures for the Scheme. *[Amended in October 2007, July 2008, June 2012 and June 2016]*

16.39 In the claim for financial assistance, a candidate/list of candidates should deduct the estimated value of the reused publicity materials (the expenses of which had been the subject of claims for financial assistance in a previous election) from calculation of the amount of financial assistance to be made payable to the candidate/list of candidates. *[Added in June 2012 and amended in June 2016]*

Making Claims and their Submissions

Requirements to be complied with when making claims

16.40 A claim for financial assistance shall be made by a candidate/list of candidates in a specified form (which will be provided by the REO at the time when candidates submit their nominations). It shall be signed by the candidate, or in respect of a list of candidates by all candidates on the list (or if there is only one candidate on the list, by that candidate). The claim form shall be accompanied by:

- (a) an election return made under s 37 of the ECICO; and
- (b) an auditor's report which confirms that an auditor has audited the account of the declared election expenses by conducting a reasonable assurance engagement in accordance with the Hong Kong Standards on Assurance Engagements, and states the

auditor's opinion as to whether the election return complies with s 37(1)(a) and (2)(b)(i) and (v) of the ECICO in all material respects.

[S 3 of the EAC (FA) (APP) Reg] *[Amended in October 2007]*

16.41 A set of guidance notes will be prepared by the REO with assistance by the Hong Kong Institute of Certified Public Accountants ("HKICPA") for auditors who are engaged by candidates to perform the auditing task. These notes will be issued by the HKICPA to its members prior to the LegCo election. *[Amended in October 2007]*

16.42 Since the auditing fee is not incurred for the purpose of promoting candidature or prejudicing another candidate, it should not be regarded as an election expense. Accordingly, an elected candidate could accept an advantage to meet the auditing fee incurred and he/she would not be required to report the acceptance in his/her election return. If an elected candidate decides to accept such an advantage, he/she should ensure that the acceptance is not in breach of the relevant provisions in s 4 of the POBO.

Submission of claims

16.43 The claim form, together with the accompanying documents, shall be submitted in person at the office of the CEO by the candidate or one of the candidates of a list of candidates (or if there is only one candidate on the list, by that candidate) who has signed the claim form, or his/her agent, before expiry of the period, or extended period provided for in s 37 of the ECICO for lodging an election return [see para. 16.26 above] [s 37(1B) and (1C) of the ECICO and s 4 of the EAC (FA) (APP) Reg]. *[Amended in October 2007, June 2012 and June 2016]*

Verification of Claims

Verification by the CEO

16.44 On receiving a claim, the CEO will check the eligibility for financial assistance of the candidate/list of candidates. He/She will also verify whether the claim conforms to the requirements set out in the EAC (FA) (APP) Reg.

Requirement for further information

16.45 The CEO may, through a written request, require the claimant to provide further information to verify the claim. The claimant must provide the information within 14 days from the date of receipt of the written request or within the period or extended period provided for in s 37 of the ECICO for lodging an election return, whichever is later. If the claimant fails to provide the information within the period, the CEO may stop processing the claim without any prior notice. [S 5(3), (5) and (6) of EAC (FA) (APP) Reg] *[Amended in June 2012]*

Part processing of claims

16.46 If an auditor's report states that only part of the election return complies with the requirements set out in the relevant sections of the ECICO, the CEO may process that part of the return that complies with those requirements and may stop processing the part of the return that does not comply with those requirements [s 6 of the EAC (FA) (APP) Reg]. *[Amended in October 2007]*

Withdrawal of Claims

16.47 A claim may be withdrawn before a payment of financial

assistance is made by submitting a notice of withdrawal at the office of the CEO. The notice has to be served in person by the candidate, or by one of the candidates in the case of a claim made by a list of candidates (or if there is only one candidate on the list, by that candidate), or his/her agent. The notice of withdrawal must be in a specified form and signed by the candidate, or by all the candidates in the case of a claim made by a list of candidates. [S 7 of the EAC (FA) (APP) Reg] *[Amended in October 2007]*

Payment of Claim after Verification

Payment to be made by the Director of Accounting Services

16.48 After verifying the claim, the CEO will certify the amount of financial assistance and notify the Director of Accounting Services (“DAS”) of the amount payable and the person to whom it is to be paid. As soon as practicable after receiving the notification, the DAS must make the payment in accordance with the notification. In the case of a list of more than one candidate, the payment is to be made to the candidate who is nominated in the claim form to receive the payment on behalf of the candidates on the list. [S 8 of the EAC (FA) (APP) Reg]

Recovery of Payment

16.49 Where a payment of financial assistance is made and the recipient is not entitled to receive the whole or part of the amount paid, the CEO is required to send a written notice under s 60H(1)(a) of the LCO by registered post to the recipient requiring repayment within 3 months after the date of notice. The recipient may make the repayment, in person, at the office of the CEO or send the repayment by post. [S 12(1) of the EAC (FA) (APP) Reg] *[Amended in June 2012]*

**PART VII : SPECIAL FEATURES APPLICABLE TO THE LIST
OF CANDIDATES IN A GEOGRAPHICAL
CONSTITUENCY AND THE DISTRICT COUNCIL
(SECOND) FUNCTIONAL CONSTITUENCY
ELECTION**

16.50 The guidelines in this chapter and the provisions of the ECICO apply generally to each and every candidate who is on a list of candidates. This Part draws attention of those candidates and their agents to the special features that are applicable to the list of candidates in a GC/DC (second) FC.
[Amended in June 2012]

16.51 As stated in item (a) and (f) of para. 16.10 above, a particular ceiling of election expenses applies to each list of candidates in the case of GC/DC (second) FC. The election expenses to be incurred by all the candidates on a list of candidates, or a single candidate on the list, cannot exceed the applicable ceiling, or else all the candidate(s) on the list of candidates will be guilty of an illegal conduct under s 24 of the ECICO.
[Amended in June 2012]

16.52 Any election expenses incurred by or on behalf of a candidate on a GC/DC (second) FC list for promoting the election of the candidate/list of candidates, or for prejudicing the election of another candidate/list of candidates, or any one of such candidates [see para.16.2 above] will necessarily be election expenses incurred for the whole list of candidates, because they are not only incurred for a particular candidate, but for promoting or benefiting the election of that list of candidates in its entirety, regardless of the candidate's rank of priority on that list of candidates. An authorisation to an election expense agent, regardless of whether or not he/she is one of the candidates on the GC/DC (second) FC list, to incur election expenses for a candidate on the list of candidates, therefore, must necessarily be an **authorisation** to incur

election expenses for all the candidates on the list of candidates, and thus it needs to be **signed by all the candidates on the list**, and not just by one or some of the candidates only. By the same reason, each candidate on the same GC/DC (second) FC list must authorise the other fellow candidate(s) to be his/her election expense agent(s), or otherwise none of the other fellow candidates can lawfully incur election expenses for him/her, or for the whole list which includes him/her. The election expenses incurred by any candidate on a GC/DC (second) FC list individually, whether before or after the formation of the list, form part of the election expenses capped by the applicable ceiling and must be counted towards the maximum amount allowed.
[Amended in June 2012]

16.53 In order to ensure that each of the candidates on a list of candidates will cross-authorise one another as his/her election expense agent(s), they will be required to complete and jointly sign a **declaration of election expenses already incurred and cross-authorisation form** and submit it to the relevant RO or the CEO, as the case may be, for the following purposes:

- (a) to declare the amount of election expenses each of the candidates has already incurred for himself/herself before formation of the list and up to the time when the declaration is made;
- (b) to declare the amount of election expenses each of the candidates and each election expense agents is authorised to incur for the list for the election campaign which, taking into account the expenses already incurred as referred to in (a) above, should not exceed the election expense ceiling applicable to the concerned GC/DC (second) FC; and
- (c) for each of the candidates to cross-authorise each other and to authorise the election expense agents to incur election expenses

up to the amounts declared in (b) above.

It is important to note that the authorisation is not effective until it has been received by the relevant RO or the CEO, as the case may be. So long as the sum total of the amounts in (a) and (b) above does not exceed the applicable ceiling for the concerned GC/DC (second) FC, the candidates on the list of candidates can decide the exact amount each is to expend for their campaign. However, candidates are advised that it would be wise to reserve a comfortable cushion below the ceiling when making the initial decision. The reason is that if any one of them wishes to expend above the amount to be incurred as declared in (b), this further expenditure could be covered by the cushioned amount. Moreover, since each candidate on a GC/DC (second) FC list is an election expense agent, he/she cannot by himself/herself delegate to any third party to incur election expenses for the GC/DC (second) FC list. Any election expense agent must receive a written authorisation from **all** the candidates on the GC/DC (second) FC list **before** he/she can incur such expenses without contravening s 23 of the ECICO. *[Amended in June 2012]*

16.54 If there is any proposed alteration of the amount of election expenses any one of the candidates on a GC/DC (second) FC list has been authorised to incur under the cross-authorisation referred to in para. 16.53(b) above, all candidates of the GC/DC (second) FC list are required to sign another declaration form for the purpose and submit it to the relevant RO or the CEO, as the case may be. If there is any proposed alteration of the amount of election expenses that any election expense agent has been authorised by all the candidates on a GC/DC (second) FC list to incur, the same procedure applies. *[Amended in June 2012]*

16.55 The reasoning set out in para. 16.52 above applies similarly to election donations.

16.56 **All candidates** on a GC/DC (second) FC list are required to

complete an election return which has been signed jointly before a Commissioner for Oaths or other authorised persons after the election. A single candidate on a list is **not** required to complete Part III. In the form, election donations must include the amount of contribution each of the candidates has made and election donations received from other sources for the election campaign for the promotion of the whole GC/DC (second) FC list. Each candidate on a GC/DC (second) FC list is responsible for the amount of election expenses he/she has incurred and been authorised to incur by the other fellow candidates on the list, which must be stated in the return with supporting invoices and receipts. *[Amended in June 2012 and June 2016]*

16.57 Candidates from the traditional FCs need to complete a different form of election return. *[Amended in June 2012]*

PART VIII : ENFORCEMENT AND PENALTY

Enforcement

16.58 The election returns will be made available at the REO for public inspection up to the 60th day before the first anniversary of the date of the deadline for lodging the relevant election return (disregarding any order made by the CFI under s 40 of the ECICO allowing a candidate to lodge an election return within a further period as specified by the CFI) [please see para. 16.26 above]. Copies of the election returns will be furnished to any person upon request subject to payment of copying fee at a fixed rate. [S 41 of the ECICO] *[Amended in June 2016]*

16.59 Any complaint or report of breach of these guidelines may be made to the relevant RO, the REO, the EAC or its Complaints Committee direct. The EAC or its Complaints Committee may, after consideration, refer the cases to the relevant authorities for investigation and prosecution.

16.60 The REO will check all election returns. Irregularities detected will be reported to the relevant authorities for investigation.

Penalties

16.61 It is an illegal conduct for a candidate to incur election expenses in excess of the maximum amount prescribed. It is also an illegal conduct for a person, other than a candidate or a candidate's election expense agent, to incur election expenses. An election expense agent engages in illegal conduct if he/she incurs election expenses in excess of the amount authorised. Such an illegal conduct is liable to a fine of \$200,000 and to imprisonment for 3 years [ss 22, 23 and 24 of the ECICO].

16.62 A candidate who uses any election donation for any purpose other than for meeting his/her election expenses, or fails to dispose of unspent or excessive election donations in accordance with s 19 of the ECICO commits a corrupt conduct liable to a fine of \$500,000 and to imprisonment for 7 years. [Ss 6, 18 and 19 of the ECICO]

16.63 A candidate who fails to submit the election return by the prescribed date or who fails to provide an accurate account of all election expenses incurred and all election donations received with the required supporting invoices and receipts issued by recipients of the payments commits an offence and will be liable to a fine of \$200,000 and to imprisonment for 3 years [s 38(1) of the ECICO]. *[Amended in June 2012]*

16.64 A candidate who knowingly makes a materially false or misleading statement in his/her election return lodged under s 37 of the ECICO or a copy of an election return lodged under s 37A of the ECICO, commits a corrupt conduct liable to a fine of \$500,000 and to imprisonment for 7 years [ss 6 and 20 of the ECICO]. *[Amended in June 2012 and June 2016]*

16.65 A candidate, who, having been elected to the LegCo, acts in the office or participates in the affairs of the LegCo, without filing the election return before the end of the permitted period commits an offence and will be liable to a fine of \$5,000 for each day on which a candidate acts in the office or participates in the affairs of the LegCo as a member without having complied with s 37 of the ECICO [s 39(1) and (2) of the ECICO]. *[Amended in June 2016]*

16.66 A person convicted of a **corrupt conduct or illegal conduct** within the meaning of the ECICO will, in addition to the penalties set out in paras. 16.61 to 16.65 above, be disqualified:

- (a) from being nominated as a candidate for the election of, or from being elected as, the CE, a member of the LegCo or DC or a RR, if the election is held within 5 years after the date of conviction [ss 14 and 20 of the Chief Executive Election Ordinance (Cap 569) (“CEEEO”), s 39 of the LCO, s 21 of the DCO and s 23 of the Rural Representative Election Ordinance (Cap 576) (“RREO”)]; and
- (b) from being nominated as a candidate at Election Committee (“EC”) Subsector Elections and from being elected as a member of the Election Committee if the election is held within 3 years after the date of conviction, or from being nominated as an EC member by the religious subsector for 3 years from the date of conviction [ss 9 and 18 of the Schedule to the CEEEO].

[Amended in October 2007, January 2010, June 2012 and June 2016]

CHAPTER 17

CORRUPT AND ILLEGAL CONDUCT

PART I : GENERAL

17.1 This chapter sets out the guidelines against corrupt and illegal conduct in conducting election-related activities. It is important that candidates are aware of the common pitfalls in election activities, which may involve corrupt and illegal conduct, and take appropriate preventive measures to guard against committing offences out of oversight.

17.2 Provisions relating to corrupt and illegal conduct can be found in the ECICO. To help candidates and their agents to get acquainted with the major provisions of the Ordinance, the ICAC had prepared an Information Booklet on “Clean Legislative Council Election” for distribution to candidates. The content of the Information Booklet will also be uploaded onto the website of the ICAC (www.icac.org.hk/elections). *[Amended in June 2012]*

17.3 The ECICO and the guidelines in this chapter apply generally to the elections in respect of the GCs and FCs. For the special features applicable to the system of the list of candidates in the GC and DC (second) FC elections, please also see Part VII of Chapter 16. *[Amended in June 2012]*

17.4 A person who engages in:

- (a) a **corrupt conduct** will be liable to a fine of \$500,000 and to imprisonment for 7 years and to pay to the court the amount or value of any valuable consideration he/she or his/her agents received in connection with the conduct or such part of the

amount or value as specified by the court [s 6(1) and (3) of the ECICO]; and

- (b) an **illegal conduct** will be liable to a fine of \$200,000 and to imprisonment for 3 years [s 22(1) of the ECICO].

In addition to these penalties, a convicted person will be disqualified from being nominated as a candidate in future elections. For details, please see para. 17.33 below. *[Amended in January 2010]*

17.5 The ECICO applies to all conduct concerning an election, whether the conduct is engaged in within Hong Kong or elsewhere. [S 5 of the ECICO] *[Added in June 2016]*

PART II : CORRUPT CONDUCT RELATING TO NOMINATION AND WITHDRAWAL OF CANDIDATURE

Offences Relating to Candidature

17.6 Any act to affect a person's candidature by bribery, force, duress or deception is prohibited. Candidature includes standing as a candidate, not standing as a candidate, or withdrawal of nomination. It will be a corrupt conduct if a person corruptly:

- (a) offers an advantage to another person as an inducement or reward to affect his/her candidature or for not using his/her best endeavours to promote his/her election;
- (b) offers an advantage to another person as an inducement or reward to affect the candidature of a third person or get the third person not to use his/her best endeavours to promote his/her election;

- (c) solicits or accepts an advantage from another person as an inducement or reward to affect the candidature of himself/herself or for not using his/her best endeavours to promote his/her election; or
- (d) solicits or accepts an advantage from another person as an inducement or reward to affect the candidature of a third person or get the third person not to use his/her best endeavours to promote his/her election.

[S 7(1) of the ECICO]

17.7 Similarly, a person engages in corrupt conduct if he/she uses or threatens to use force or duress against another person to affect the candidature of that person or a third person. The use of deception to induce another person to affect the candidature of that person or a third person is also a corrupt conduct. [Ss 8 and 9 of the ECICO] *[Amended in June 2012]*

17.8 It will also be a corrupt conduct if a person defaces or destroys a completed or partly completed nomination paper with intent to prevent or obstruct another person from standing for election [s 10 of the ECICO]. *[Amended in June 2012]*

PART III : ILLEGAL CONDUCT RELATING TO ELECTIONEERING

False Statement that a Person is or is not a Candidate

17.9 A person must not publish any statement that he/she is no longer a candidate at an election if he/she is a candidate, or that another person who

has been nominated as a candidate is no longer a candidate at the election, or that he/she or another person is a candidate at an election, knowing that the statement is false [s 25 of the ECICO].

False or Misleading Statement about a Candidate

17.10 A person must not publish any materially false or misleading statement of fact about a particular candidate or particular candidates for the purpose of promoting or prejudicing the election of the candidate or candidates. Similarly, a candidate must not publish any materially false or misleading statement of fact about himself/herself or another candidate or other candidates for the purpose of promoting the election of himself/herself or prejudicing the election of another candidate or other candidates. Any such publication will amount to an illegal conduct. [S 26 of the ECICO] It should be noted that materially false or misleading statements about a candidate or candidates include, but are not limited to, statements concerning the character, qualifications or previous conduct of the candidate or candidates to promote or prejudice the election of the candidate or candidates, e.g. a person who makes a materially false or misleading statement of fact about a candidate, thereby calling into question the integrity and honesty of that candidate, may contravene the above provision. Any person who wishes to publish a statement about a candidate or candidates should make every effort to ensure its accuracy before its publication. *[Amended in June 2012]*

Claim of Support

[Please also see Chapter 18.]

17.11 A candidate engages in illegal conduct if he/she fails to obtain **prior written consent** from a person or an organisation before using the name or logo of that person or organisation, or a pictorial representation of that person in any of his/her EAs as an indication of support from that person or organisation unless he/she has neither requested or directed nor authorised any

person to request or direct the inclusion of the aforesaid name, logo or pictorial representation in his/her EAs. Also, should any content of an EA (where either the candidate has obtained the prior written consent mentioned above or the candidate has neither requested or directed nor authorised any person to request or direct the inclusion of the name, logo or pictorial representation in his/her EAs) be provided by a person or an organisation, the candidate engages in illegal conduct if he/she modifies, or authorises any person to modify, the name, logo, or pictorial representation or the content unless **before** the modification, the person or organisation concerned **consented in writing** to the name, logo, pictorial representation or content as modified. Oral consent is **not** sufficient. [S 27(1), (1A) and (1B) of the ECICO] The EAC provides a sample consent form for this purpose. A candidate is required to post a copy of the consent form relevant to the EA concerned onto the Candidate's Platform or Central Platform or deposit a copy of the consent form with the relevant RO in the manner as set out in para. 8.50 of Chapter 8 [s 105(2) and (3) of the EAC (EP) (LC) Reg]. It is important to note that it is still an offence even if such an EA contains a statement to the effect that it does not imply support from the person or organisation concerned [s 27(4) of the ECICO]. It is also an offence for a person to give information which he/she knows or ought to know is materially false or misleading to a candidate or candidates for promoting or prejudicing the election of the candidate or candidates [s 27(6) of the ECICO]. *[Amended in October 2007, July 2008, June 2012 and June 2016]*

17.12 A person or an organisation may give support to a list of candidates, to one or more of the candidates on a list of candidates, or to a single candidate on a list. Support can be also given to 2 or more candidates or 2 or more lists of candidates, even if they are competing in the same constituency, although that may cause confusion. This should be specified in the written consent. A sample form on seeking "**Consent of Support**" prepared by the EAC will be available at the REO and RO's office and can be downloaded from the REO website after the gazettal of a notice specifying a period and place for submitting nomination forms. It will also be provided to

a candidate upon his/her submission of a nomination form for the election. Candidates should take care to ensure that their EAs make clear where support is claimed whether it is for the whole list of candidates or for individual candidate(s) on a list of candidates. Candidates are reminded that it is an offence to make a false claim of support [see Chapter 18]. *[Amended in June 2012 and June 2016]*

17.13 Candidates on a list of candidates must be very careful in their EAs to describe **precisely** the support obtained by them or only one of them from supporters (as evidenced by a completed form of consent of support) to ensure that there is no false claim of support [see also para. 16.14 of Chapter 16]. *[Amended in June 2012]*

17.14 Consent given can be revoked. In case of a revocation, in order to avoid dispute, it is advisable for the person or organisation who has revoked the consent to send a notice or copy of the revocation to the candidate concerned. In such case, the candidate is required to notify the relevant RO in writing of any revocation of consent or post a notice or copy of the revocation onto the Candidate's Platform or the Central Platform in the manner as set out in para. 8.50 of Chapter 8. The candidate concerned should cease to publish immediately any EA which contains the support of the person or organisation who has made the revocation. *[Amended in June 2012 and June 2016]*

17.15 S 28 of the ECICO provides for an injunction order by the Court to restrain the publication of any materially false or misleading statement or false claim of support. An application for such an injunction order may be made by a candidate in the same constituency, his/her election agent, an elector in the same constituency and the person or body to whom or which the false information is related.

PART IV : CORRUPT CONDUCT RELATING TO ELECTIONEERING AND VOTING

Bribery

17.16 Any act to affect a person's voting preference by offering or soliciting or accepting an advantage is prohibited [s 11 of the ECICO]. Voting preference covers voting for a particular candidate or particular candidates, not voting at an election, or not voting for a particular candidate or particular candidates.

Treating

17.17 A person must not at any time provide or meet all or part of the cost of providing another person with any food, drink or entertainment for the purpose of influencing that person's or a third person's voting preference. Likewise, the corrupt solicitation or acceptance of any such treating is prohibited [s 12 of the ECICO].

17.18 The serving of non-alcoholic drinks only at an election meeting, without more, will not be deemed corrupt for the above purposes [s 12(5) of the ECICO]. An election meeting is any meeting held to promote or prejudice the election of a particular candidate or particular candidates. [See Chapter 10]

17.19 If a person or an organisation hosts a banquet for a non-election-related purpose but, during the occasion, calls on the guests to vote for a particular candidate and if the candidate is present, the candidate concerned should immediately stop any promotion of his/her election and disown or dissociate with whatever has been said or done to promote his/her candidature. Otherwise, the occasion will be regarded as an election meeting held to promote his/her candidature and expenses incurred will have to be counted towards his/her election expenses. At the same time, the host who

uses the meeting for promoting the candidate may also be liable for prosecution for his/her failure in obtaining the candidate's prior authorisation to appoint him/her as the candidate's election expense agent for incurring election expense on behalf of the candidate. [See para. 10.2 above and s 23 of the ECICO] *[Amended in June 2012 and June 2016]*

17.20 If a candidate or another person offers food, drink or entertainment to affect a person's voting preference, it is an offence under s 12 of the ECICO. *[Amended in June 2012 and June 2016]*

Force and Duress

17.21 The use of or the threat to use force or duress against a person to induce him/her to vote or not to vote at an election, or to vote or not to vote for a particular candidate or particular candidates or to get a third person to do so is a corrupt conduct [s 13 of the ECICO]. *[Amended in June 2012]*

17.22 Persons in position to exert pressure and influence on others should be careful not to breach the provisions under the ECICO, e.g. employers over employees, school principals or teachers over students, religious advisers over believers and doctors over patients, etc.

Voting Offences

17.23 It is a corrupt conduct for any person:

- (a) to vote at an election knowing that he/she is not entitled to vote at that election;
- (b) to vote at an election after having knowingly or recklessly given materially false or misleading information to an electoral officer, or to vote at an election after having knowingly omitted to give

material information to an electoral officer;

- (c) except as expressly permitted by an electoral law,
 - (i) to vote at an election more than once in the same GC, or to vote in more than one GC; or
 - (ii) to vote more than once in the same FC, or vote in more than one FC; or *[Amended in June 2012]*
- (d) to invite or induce another person to commit (a), (b) or (c) above.

[S 16(1) and (2) of the ECICO]

Candidates must note that all their electioneering and canvassing activities must be conducted within the statutory confines of the ECICO. While candidates may engage in activities to promote themselves or to assist or facilitate electors to vote in an election, they must be extremely careful to ensure that these activities are not in breach of the provisions of the ECICO all the time. *[Amended in June 2012 and June 2016]*

PART V : CORRUPT AND ILLEGAL CONDUCT RELATING TO ELECTION EXPENSES AND ELECTION DONATIONS

17.24 Candidates should be careful when handling election expenses and election donations as non-compliance with the relevant requirements will be a corrupt or illegal conduct. For details of the requirements that have to be observed, please refer to Chapter 16.

PART VI : POWER OF COURT TO EXCUSE INNOCENT ACTS

17.25 S 31 of the ECICO provides a mechanism for a candidate to apply for a Court order to relieve himself/herself of criminal responsibility if he/she contravenes the illegal conduct provisions due to inadvertence, accidental miscalculation or any reasonable cause and not due to bad faith. No prosecution against him/her may be instituted or carried on until the application is disposed of by the Court. He/She will not be liable to be convicted of an offence if the illegal conduct is the subject of a Court order.

17.26 A candidate who is unable or has failed to send to the CEO the election return before the end of the permitted period due to his/her own illness or absence from Hong Kong, or the death, illness, absence from Hong Kong or misconduct of any agent or employee of the candidate, or by reason of inadvertence or accidental miscalculation by the candidate or any other person, or any reasonable cause, and not due to the candidate's bad faith, can make an application to the CFI for an order to allow him/her to send in the election return within a further period as specified by the CFI [s 40(1) and (2) of the ECICO]. *[Amended in June 2012]*

17.27 If a candidate makes an error or a false statement in the election return due to misconduct of any agent or employee of the candidate, or by reason of inadvertence or accidental miscalculation by the candidate or any other person, or any reasonable cause, and not due to the candidate's bad faith, he/she may apply to the CFI for an order to enable him/her to correct any error or false statement in the election return or in any document accompanying the election return [s 40(3) and (4) of the ECICO]. *[Added in June 2012]*

17.28 When the candidate finds himself/herself in any of the situations set out in paras. 17.26 and 17.27 above, other than the situations where correction of errors or false statements is allowed under the relief arrangement

in para. 16.31 of Chapter 16, it would be wise of him/her to make the application to the CFI and inform the REO as soon as possible. *[Amended in October 2007 and June 2012]*

PART VII : NON-COMPLIANCE WITH THE LAW AND SANCTION

17.29 Any complaint or report of breach of these guidelines may be made to the relevant RO, the REO, the EAC or its Complaints Committee direct. The EAC or its Complaints Committee may, after consideration, refer the cases to the relevant authorities for investigation and prosecution. *[Amended in June 2016]*

17.30 The ICAC may, subject to the decision of the Secretary for Justice, prosecute, issue a warning or caution to candidates and any other persons in appropriate cases concerning any breach of the electoral law or regulation, especially the ECICO.

17.31 The Director of Public Prosecutions has informed the EAC that the Department of Justice will not hesitate to prosecute appropriate cases of electoral offences.

17.32 The EAC may also issue public statements in such manner as it deems fit to reprimand or censure any non-compliance with these guidelines.

17.33 A person convicted of a **corrupt conduct or illegal conduct** within the meaning of the ECICO will, in addition to the penalties set out in para. 17.4 above, be disqualified:

- (a) from being nominated as a candidate for the election of, or from being elected as, the CE, a member of the LegCo or DC, or a

RR, if the election is held within 5 years after the date of conviction [ss 14 and 20 of the CEEO, s 39 of the LCO, s 21 of the DCO and s 23 of the RREO]; and

- (b) from being nominated as a candidate at EC Subsector Elections and from being elected as a member of the Election Committee if the election is held within 3 years after the date of conviction, or from being nominated as an EC member by the religious subsector for 3 years from the date of conviction [ss 9 and 18 of the Schedule to the CEEO].

[Amended in October 2007, January 2010, June 2012 and June 2016]

17.34 It is worth noting that the Courts of Hong Kong view election-related offences and contravention of the ECICO being serious crimes. On 27 November 1997, the Court of Appeal laid down sentencing guidelines that a person found guilty of any serious election-related offence should be punished by an immediate custodial sentence. *[Amended in October 2007]*

CHAPTER 18

NAMEDROPPING

Claim of Support

18.1 A candidate engages in illegal conduct if he/she fails to obtain **prior written consent** from a person or an organisation before using the name or logo of that person or organisation, or a pictorial representation of that person in any of his/her EAs as an indication of support from that person or organisation unless he/she has neither requested or directed nor authorised any person to request or direct the inclusion of the aforesaid name, logo or pictorial representation in his/her EAs. Also, should any content of an EA (where either the candidate has obtained the prior written consent mentioned above or the candidate has neither requested or directed nor authorised any person to request or direct the inclusion of the name, logo or pictorial representation in his/her EAs) be provided by a person or an organisation, the candidate engages in illegal conduct if he/she modifies, or authorises any person to modify, the name, logo, or pictorial representation or the content unless **before** the modification, the person or organisation concerned **consented in writing** to the name, logo, pictorial representation or content as modified. [S 27(1), (1A) and (1B) of the ECICO] [*Amended in June 2012*]

[Please also see paras. 17.11 to 17.15 of Chapter 17 especially regarding the GC and the DC (second) FC.]

18.2 Oral or retrospective consent is **not** sufficient. The EAC provides a sample consent form for this purpose. The written consent is a requirement under the ECICO. It protects the candidates from unnecessary complaints and disputes which may arise if only oral consent is obtained. It also protects the electors from being misinformed as to whether a candidate has the support of a person or an organisation. Prior written consent is required if

the inclusion of the name, logo or pictorial representation of a person or an organisation, as the case may be, implies support of the candidate concerned. What amounts to “support” will depend on the circumstances of each case. The question to consider is whether any reasonable person who has seen the pictorial representation would have the perception that the persons appearing in the EA support the candidate. *[Amended in June 2012 and June 2016]*

18.3 It is important to note that it is still an offence even if such an EA contains a statement to the effect that it does not imply support from the person or organisation concerned [s 27(4) of the ECICO]. It is also an offence for a person to give information which he/she knows or ought to know is materially false or misleading information to a candidate or candidates for the purpose of promoting or prejudicing the election of the candidate or candidates [s 27(6) of the ECICO].

18.4 For the avoidance of doubt, it is advisable for the written consent to set out clearly whether consent is given:

- (a) by a supporter in his/her personal capacity - in which case no mention should be made of any office title which he/she may have, in the candidate’s/list of candidates’ EAs and campaign activities;
- (b) by a supporter with the mention of his/her office title (bearing no reference to the name of the organisation concerned) - in which case the consent should indicate whether the supporter consents to the mention of his/her office title(s) and the description of such a title(s). Where such office title(s) is/are to be mentioned in an EA, the supporter and the candidate/list of candidates should take particular care to ensure that the information should not be used in such a way to misrepresent the support of the organisation(s) concerned.

For example, where the office title of “the school principal” (for example, “Chan Tai Man, the Principal”) or “chairman of an owners’ corporation” (for example, “Chan Tai Man, Chairman of Owners’ Corporation”) is to be included in an EA, and if the EA is to be posted in the school or the building in which he/she is serving, it would be desirable for the candidate to seek the relevant organisation’s prior written approval;

- (c) by a supporter with the mention of his/her office title and the name of the organisation concerned - in which case the candidate/list of candidates should ensure that the supporter has obtained the prior written approval of the organisation, in accordance with the organisation’s internal rules and procedures or any established convention (e.g. approved by the governing body of the organisation or by a resolution of that organisation passed at a general meeting), for using the name of the organisation together with his/her office title(s) by the candidate/list of candidates. In case of doubt, the candidate or his/her supporter should consult the organisation concerned on its internal rules and procedures. The candidate/list of candidates should be careful not to give the impression that it represents the support of the whole organisation; and
- (d) by an organisation - in which case the consent should indicate that approval has been given by the governing body of the organisation or by a resolution of the members of the organisation passed at a general meeting [s 27(5) of the ECICO]. The consent must be signed by an authorised person such as its director, chairman or chief executive, etc.

18.5 Candidates should note that the Home Affairs Department has its own guidelines for MACs and their office-bearers in respect of their giving consent of support to candidates. A copy of such guidelines can be found at **Appendix S**.

18.6 Consent can be given to 2 or more candidates or 2 or more lists of candidate(s) of a GC/DC (second) FC, even if they are competing in the same constituency, although that may cause confusion. A consent given can be revoked. In case of revocation, in order to avoid dispute, it is advisable for the person or organisation who has revoked the consent to send a notice or copy of the revocation to the candidate/list of candidates concerned. The candidate/list of candidates is required to notify the relevant RO in writing of any revocation of consent or post a notice or copy of the revocation onto the Candidate's Platform or the Central Platform in the manner as set out in para. 8.50 of Chapter 8. *[Amended in June 2012 and June 2016]*

18.7 Once consent has been revoked, the candidate concerned should be careful to cease immediately using any EA which contains the support of the person or organisation who has made the revocation. The costs incurred for the production of EAs bearing such support should still be regarded as the candidate's election expenses and be declared in the election return. *[Amended in June 2016]*

18.8 If candidate A's name or photograph appears in the EA of candidate B to indicate support for candidate B, whether expenditure incurred for an EA will need to be borne by candidate A would depend on whether the publicity material in question has explicitly or implicitly promoted the election of candidate A. There may be 2 different scenarios in such cases:

Scenario A

If the appearance of candidate A in candidate B's EA is solely to

indicate support for candidate B but not to promote the election of candidate A, the EA should not be treated as a joint EA. The election expenses incurred should be counted as candidate B's election expenses only, but not as candidate A's. Candidate B has to obtain the prior written consent of support from candidate A before using candidate A's names or photographs in his/her EAs [s 27 of the ECICO].

Scenario B

If candidate B wishes to publish the EAs for promoting his/her candidature and that of candidate A as well, he/she must obtain prior written authorisation from candidate A to act as his/her election expense agent and the expenses so incurred will have to be borne by the candidates A and B in equal or proportional shares as their respective election expenses, to be calculated by the proportion of the size of the portion advertising each.

It should be noted that the EA mentioned in Scenario B above should be treated as a joint EA. To comply with the requirement stipulated in s 27 of the ECICO, both candidates A and B also have to seek written consent of support from each other before publishing the joint EA. *[Added in June 2012]*

18.9 It is not uncommon for candidates to put photographs with the appearance of other persons (which may include other candidates in the election) in their EAs to show their past activities. However, it may be possible for electors to believe that those persons appearing in the photograph support a particular candidate when they receive such EAs. To avoid misunderstanding, for instance, if an EA carries a photograph of the candidate attending an activity with other attendees, a caption specifying the particular nature of the event could be added underneath the photograph in such a way

that will not imply, or likely to cause electors to believe, that the candidate has the support of those persons appearing in the photograph. If in the circumstances the photograph is likely to cause electors to believe that the candidate has the support of those persons appearing in the photograph, prior written consent of support should be obtained by the candidate. *[Amended in June 2012]*

18.10 To avoid misleading the electors to believe that a candidate has obtained support from a certain person, organisation, government agency or department, which is not the case, a candidate should not attach any materials published by any such person, organisation, government agency or department together with his/her own EAs.

18.11 As advised by the OPCPD, an image of an identified person¹⁶ will constitute his/her personal data and its use for a purpose other than the original purpose of collection or a directly related purpose, without the consent of the person concerned, will be an infringement of his/her personal data. Therefore, candidates when using the aforesaid image should also observe the relevant data protection principle as set out in the guidance notes on personal data privacy in respect of electioneering activities at **Appendix I**. *[Added in June 2012 and amended in June 2016]*

Form of Consent

18.12 A sample form on seeking “**Consent of Support**” prepared by the EAC will be available at the REO and RO’s office and can be downloaded from the REO website after the gazettal of a notice specifying a period and place for submitting nomination forms. It will also be provided to a candidate upon his/her submission of a nomination form for the election. It should be noted that the form is designed to cover a specific constituency in a particular

¹⁶ “An identified person” shall refer to a person appearing in a photograph whose identity is known to members of the public either because his/her name is mentioned in the photo caption or he/she can easily be identified by virtue of his/her job, profession or business, etc.

election. A candidate who subsequently switches to another constituency should seek afresh the consent from the person or organisation concerned. *[Amended in June 2012 and June 2016]*

18.13 There are occasions (as allegations and complaints were received) requiring confirmation of the compliance of the law by a candidate. Therefore, a candidate is required to post a copy of the written consent relevant to the EA concerned onto the Candidate's Platform or Central Platform or deposit a copy of the written consent with the relevant RO in the manner as set out in para. 8.50 of Chapter 8 [s 105(2) and (3) of the EAC (EP) (LC) Reg]. A candidate is also **required to post** onto the Candidate's Platform or Central Platform a written notice of revocation **or notify** the relevant RO of such revocation in the manner as set out in para. 8.50 of Chapter 8. Such written consent and notices of revocation received by the RO will be made available for public inspection (with the identity document numbers, if any therein, of the persons involved obliterated) at the office of the relevant RO. *[Amended in June 2012]*

Penalty

18.14 It is an illegal conduct under the ECICO for a person to make false claim of support. For details of penalty and sanction, please refer to para. 17.4(b) and Part VII of Chapter 17. *[Amended in June 2012]*

CHAPTER 19

PARTICIPATION IN ELECTION-RELATED ACTIVITIES BY CIVIL SERVANTS AND OFFICIALS UNDER THE POLITICAL APPOINTMENT SYSTEM AND ATTENDANCE OF PUBLIC FUNCTIONS BY BOTH CIVIL SERVANTS AND CANDIDATES

PART I : GENERAL

19.1 This chapter sets out the general guidelines on the participation in election-related activities of a LegCo election by civil servants and officials under the Political Appointment System and the attendance at public functions by civil servants which are also attended by candidates.

IMPORTANT :

“Candidate” includes a person who has publicly declared an intention to stand for election at any time before the end of the nomination period for the election, whether or not he/she has submitted a nomination form [s 2 of the ECICO]. The reference of “candidate” in this chapter includes a list of candidates in a GC/DC (second) FC to which the list system of proportional representation applies.

[Amended in June 2012]

PART II : PARTICIPATION IN ELECTIONEERING ACTIVITIES BY CIVIL SERVANTS

19.2 Civil servants who wish to participate in electioneering activities in a LegCo election should observe the regulations, rules and guidelines issued by the Civil Service Bureau. Civil servants, other than directorate officers, Administrative Officers, Information Officers and Police Officers and those officers acting in the above grades or ranks with a view to substantive appointment thereto i.e. other than for temporary relief purpose, may act as agents or assist in electioneering activities provided that they are not already appointed as CRO, ROs, AROs, PROs, polling or counting staff, that there is no conflict of interest with their official duties, that no use of public resources is involved, and that no government uniform is worn. To avoid any unfairness, appearance of unfairness or conflict of interest, civil servants who work in a constituency or have extensive contacts with the public in a constituency are strongly advised not to accept appointment by a candidate in the constituency to be his/her agent and/or participate in electioneering activities in the constituency concerned. Civil servants who participate in electioneering activities, including the seeking of election donations, for any candidate should not use or be seen to use any public resources in such activities. *[Amended in October 2007, June 2012 and June 2016]*

19.3 The guidelines set out in para. 19.2 above are equally applicable to the non-civil service contract staff of the Government. *[Added in June 2016]*

PART III : ATTENDANCE OF PUBLIC FUNCTIONS BY CIVIL SERVANTS

On the Occasion of Being Invited

19.4 Civil servants should exercise care in accepting invitations from persons or organisations to attend any public function that may also be attended by a candidate(s) (“the function”). *[Amended in June 2012]*

19.5 They should take such care when any person has publicly declared an intention to run for election in respect of a particular constituency or when the nomination commences, whichever is the earlier, up to the end of the polling day.

19.6 Before deciding to attend the function, a civil servant should satisfy himself/herself that:

- (a) by attending the function, he/she is performing an official duty normally required of the post he/she is currently holding; and
- (b) to his/her best knowledge, the organiser of the function has no intention whatsoever of making use of the function to promote or prejudice any candidate.

[Amended in June 2012]

When Attending

19.7 The EAC appeals to civil servants not to have photographs taken with candidates at the function since such photographs, if published, may be seen as their lending support to the candidate. A civil servant may do so, however, if the photograph taking:

- (a) arises from the need for him/her to perform his/her official duty at the function normally required of the post he/she is currently holding;
- (b) is a natural part of the function which, if he/she declines to participate, would be seen as breaching the protocol appropriate to that function; or
- (c) is participated by all other candidates of the same constituency.

[Amended in June 2012]

19.8 The guidelines set out from paras. 19.4 to 19.7 above are equally applicable to the non-civil service contract staff of the Government. *[Added in June 2012]*

PART IV : ATTENDANCE OF PUBLIC FUNCTIONS BY CANDIDATES

19.9 Similarly, the EAC appeals to all candidates who attend public functions not to have photographs taken with the civil servants, since such photographs, if published, may be seen as an unfair advantage over other candidates. A candidate may do so, however, if the photograph taking:

- (a) arises from the need for him/her to perform his/her role at the function as requested by the function organiser;
- (b) is a natural part of the function which, if the candidate declines to participate, would be seen as breaching the protocol appropriate to that function; or

- (c) is participated by all other candidates of the same constituency.

[Amended in June 2012]

PART V : OFFICIALS UNDER THE POLITICAL APPOINTMENT SYSTEM

19.10 The term “civil servants” used in the earlier parts of this chapter does not include officials under the Political Appointment System. Officials under the Political Appointment System are political appointees and they may belong to or be affiliated with political organisations. Politically appointed officials have to comply with a “Code for Officials under the Political Appointment System”. *[Amended in July 2008 and June 2012]*

19.11 Politically appointed officials may, subject to the guidelines below, participate in election-related activities. *[Amended in July 2008]*

19.12 Politically appointed officials are disqualified from being nominated as a candidate at an election of the CE, of the LegCo or of a DC. [For details related to the LegCo election, please see para. 4.5 in Chapter 4.] *[Amended in July 2008 and June 2012]*

19.13 As far as the LegCo elections are concerned, politically appointed officials should not use any public resources for any election-related activities. A politically appointed official should ensure that when taking part in such activities, great care should be taken that there is no actual or potential conflict of interest with the business of the Government or his/her own official duties. *[Amended in July 2008]*

CHAPTER 20

COMPLAINTS PROCEDURE

PART I : GENERAL

20.1 This chapter deals with the procedure for making complaints relating to any **breach or non-compliance of the Guidelines and the provisions of the EAC (EP) (LC) Reg or the spirit of them** which are for ensuring that elections are conducted honestly, fairly and openly. *[Amended in June 2012]*

20.2 A complaint against criminal, illegal or corrupt activities may be made direct to the relevant authorities such as the Police or the ICAC. The procedures for making and processing such a complaint will be handled by these authorities, and are not covered by this chapter.

PART II : TO WHOM A COMPLAINT MAY BE MADE

20.3 The EAC is an independent, impartial and apolitical body established by the EACO to deal with all matters concerning the conduct of elections including handling election-related complaints. The EAC may, if necessary, set up a **Complaints Committee** consisting of its 3 members and 1 or more judges of the District Court or High Court for the purpose of dealing with complaints. *[Amended in June 2012]*

20.4 Without limiting the right of a citizen to make a complaint to the Police or the ICAC or other authorities, a complaint for breach of or non-compliance with the Guidelines or the provisions of the EAC (EP) (LC)

Reg or relating to election matters can be made to one of the following bodies or persons:

- (a) the RO of the relevant constituency appointed by the EAC to deal with electoral arrangements;
- (b) the REO; or
- (c) the EAC or its Complaints Committee.

[Amended in June 2012]

20.5 **Caution:** if the complaint is against the conduct, behaviour, or acts of any of the REO officers or the RO personally, it should be addressed to the EAC or its Complaints Committee and marked “CONFIDENTIAL” in order to ensure that only the EAC or its Complaints Committee will receive it.

PART III : TIME AND PROCEDURE FOR MAKING COMPLAINT

20.6 The Guidelines deal with election-related activities, and any non-compliances, abuses and irregularities that can be redressed should be remedied as soon as practicably possible. It is **imperative** that **all complaints should be made as soon as possible**, for any delay in the making of complaint may result in remedial measures being useless or futile and necessary evidence being lost. Therefore, complaints should be lodged **not later than 45 days** after the date of the relevant election. *[Amended in June 2012]*

20.7 No specified or specific form is required for making a complaint. A complaint can be made either orally or in writing. A person who wishes to make an oral complaint can call the EAC Complaints Hotline. *[Amended in June 2012]*

20.8 In each case, the complainant is required to identify himself/herself and provide his/her correspondence address, telephone number and other means of communication. A written complaint must be signed. Save where it relates to a matter of minor nature or which requires urgent action, an oral complaint received will be recorded in writing and the complainant will be required to sign the written record afterwards. All personal particulars of a complainant will be **treated in strict confidence**.

PART IV : COMPLAINTS INSIDE A POLLING STATION

20.9 If a person has any complaint about whatever happens inside the polling station, he/she should follow the following procedures:

- (a) he/she should direct his/her complaint to the PRO, the Deputy PRO or an Assistant PRO immediately;
- (b) if the matter is not resolved, or if the complainant still feels aggrieved or if his/her complaint is directed at the PRO, the Deputy PRO or an Assistant PRO, he/she should as soon as possible report the matter to the RO of the constituency of the polling station by using the telephone number appearing in the guide on procedures for complaint;
- (c) where the matter is still not resolved by the RO, the complainant should without any delay telephone the EAC Complaints Hotline to report his/her complaint by giving a gist thereof. He/She should then try to obtain as much evidence as possible in order to substantiate his/her complaint. As he/she is not allowed to talk to or communicate with any elector inside the polling station, he/she may need to go outside the polling station to obtain

necessary evidence; and

- (d) a member of the EAC or its Complaints Committee or an officer of the REO will handle the complaint as soon as practicable.

A copy of the guide on procedures for handling of complaints at the polling station (together with telephone numbers of the relevant RO(s) and the EAC Complaints Hotline) will be available for inspection inside each polling station.

20.10 The PRO or his/her Deputy or Assistant PRO must record any complaint mentioned in para. 20.9(a) and (b) and any other complaints and enquiries concerning an elector's data.

PART V : THE PROCESSING OF COMPLAINT

20.11 The CEO, the ROs and the PROs are obliged under s 101 of the EAC (EP) (LC) Reg to report irregularities to the EAC or its Complaints Committee. By these guidelines, they are also required to report all complaints received by them to the EAC or its Complaints Committee. Except where a complaint is of minor nature or the RO has been delegated with the authority to deal with it, any complaint received by the RO or the REO will be forwarded to the EAC or its Complaints Committee with comments and all the relevant information relating to the complaint. When the EAC or its Complaints Committee receives a complaint, it may seek additional information and comments from the relevant RO or the REO, if necessary.

20.12 The EAC or its Complaints Committee, the RO or the REO (when they are so authorised by the EAC or its Complaints Committee), may seek further information on the complaint from the complainant or may arrange interviews with the complainant in order to seek clarification or evidence. The complainant may be required to make a statutory declaration for the truth

and correctness of his/her complaint or statement. If the further information required is not provided by the complainant or if he/she refuses to be interviewed or to make the statutory declaration, the EAC or its Complaints Committee, the RO or the REO may or may not take further action on the complaint.

20.13 All bona fide complaints will be processed and considered by the RO who has been delegated with the necessary authority or by the EAC or its Complaints Committee, as soon as reasonably practicable, taking into account the merits of the complaint with all the information and evidence gathered [s 6(3) of the EACO].

20.14 Where a complaint is substantiated, a decision will be made on the appropriate course to be taken, including one or more of the following:

- (a) take remedial measures against the matter complained of, such as the removal of EAs displayed in breach of the guidelines in that regard;
- (b) issue to the relevant person a warning on the matter under complaint after making a reasonable effort to contact the person and giving him/her a reasonable opportunity to give explanations. Where necessary, immediate rectification action against complaints proven on the spot should be taken without delay;
[Amended in October 2007]
- (c) publish a public statement of reprimand or censure against the acts or omissions and the person or persons complained of [see various chapters in these Guidelines] after making a reasonable effort to contact the person or persons and giving him/her or them a reasonable opportunity to make representations [s 6(4) of the EACO];

- (d) with or without comments, refer the matter to the ICAC for investigation and/or further action [s 5(e) of the EACO]; and
- (e) with or without comments, refer the matter to the Secretary for Justice or the Police for further action such as prosecution of the culprit [s 5(e) of the EACO].

[Amended in October 2007]

20.15 The EAC or its Complaints Committee will also notify the complainant in writing of its decision, and if the decision is that the complaint is not substantiated, it will also give reasons. It is common that a large number of complaints are received during the election period. As each complaint will be examined in detail, the investigation of all complaints may take some time to complete. *[Amended in October 2007 and June 2016]*

PART VI : ELECTORAL AFFAIRS COMMISSION'S REPORT ON COMPLAINTS

20.16 The EAC is required to report to the CE on any complaint made to it in connection with an election within 3 months of the conclusion of the election [s 8(1) and (2) of the EACO].

PART VII : OBLIGATIONS OF THE RETURNING OFFICER, THE PRESIDING OFFICER AND THE CHIEF ELECTORAL OFFICER

20.17 The RO(s), the PRO(s) and the CEO are required to report as

soon as practicable to the EAC or its Complaints Committee (in writing or otherwise as circumstances may demand) on any complaints received by them and on any occurrence which they consider to be a material irregularity relating to an election, poll or count. *[Amended in June 2012]*

PART VIII : SANCTION FOR FALSE COMPLAINT

20.18 Any person who knowingly makes or causes to be made to an ICAC officer a false report of the commission of any offence or misleads such an officer by giving false information or by making false statements or accusations is guilty of an offence and will be liable to a fine of \$20,000 and to imprisonment for 1 year [s 13B of the ICAC Ordinance (Cap 204)]. A similar offence is committed where a false report is made or false information given to a police officer [s 64 of the Police Force Ordinance (Cap 232)]. If a person knowingly makes a false complaint and gives false information to the EAC or its Complaints Committee knowing that the EAC or its Complaints Committee will refer or direct such complaint and information to the ICAC or the Police, the person concerned will similarly be guilty of the relevant offence. If a person knowingly and wilfully makes to the EAC or its Complaints Committee, the RO or the REO a statement false in a material particular and such a statement is in a statutory declaration, he/she commits an offence and will be liable to a fine and to imprisonment for 2 years [s 36 of the Crimes Ordinance (Cap 200)]. *[Amended in October 2007]*

APPENDICES

Legislative Council Election
Action Checklist for Candidates

A. Major Steps to be Observed

Before and during
Nomination Period

1. Obtain the following from the Returning Officer (“RO”), any District Office (“DO”) of the Home Affairs Department or the Registration and Electoral Office (“REO”):

- (a) Nomination Form;
- (b) Grid paper and Guide on Completion of Grid Paper (for inclusion in the official Introduction to Candidates);
- (c) the form of “Request by a Candidate for a Legislative Council Functional Constituency or a Sole Candidate on a Legislative Council Nomination List or by a Candidate for a District Council Constituency for Printing of Particulars Relating to the Candidate on a Ballot Paper” and/or the form of “Request by Candidates on a Legislative Council Nomination List with More than One Candidate for Printing of Particulars Relating to the Candidates on a Ballot Paper”, as the case may be;
- (d) the form of “Consent of a Prescribed Body for its Particulars to be Printed on a Ballot Paper in Relation to the Request by Candidate(s)”; and
- (e) the form of “Intention to Display Election Advertisements at Designated Spots”.

During Nomination
Period

2. Except where the Chief Electoral Officer (“CEO”) authorises otherwise, personally deliver the following to the RO before the end of the Nomination Period:

- (a) the duly completed Nomination Form; and

- (b) an election deposit in cash or by cashier order or crossed cheque made payable to “The Government of the Hong Kong Special Administrative Region”.

In order to avoid the risk of invalidation of the nomination due to dishonoured cheques, candidates are strongly advised to submit the election deposit in cash or cashier order.

- 3. Apply to Hongkong Post for written approval of their election advertisement (“EA”) specimens for free postage. Candidates should:
 - (a) carefully study the requirements governing free postage for EAs before deciding on the contents of their EAs and seek advice from Hongkong Post relating to postal requirements and the REO on other relevant aspects; and
 - (b) make every effort to submit their EA specimens to Hongkong Post for written approval as early as possible to allow sufficient time for revising the contents of their EA specimens, if necessary.
- 4. Obtain from the RO the following:
 - (a) a CD-ROM containing the relevant legislation and copy of the candidate forms/documents;
 - (b) an electoral boundary map of the relevant geographical constituency (“GC”) (for GC candidates only);
 - (c) forms –
 - (i) Return and Declaration of Election Expenses and Election Donations by a GC /District Council (second) Functional Constituency (“DC (second) FC”) List of Candidates or Return and Declaration of Election Expenses and Election Donations

Appendix A
(Page 3/20)

by a FC (other than the DC (second) FC) Candidate (thereafter referred to as “election return”)

- (ii) Standard Receipt for Election Donations to a GC/DC (second) FC Candidate List or Standard Receipt for Election Donations to Individual Candidates on a GC/DC(second) FC Candidate List or Standard Receipt for Election Donations to a Candidate for a FC (other than the DC (second) FC)
- (iii) Declaration of Election Expenses Already Incurred/Cross-Authorisation and Authorisation to Incur Election Expenses by a List of Candidates in a GC/DC (second) FC Election or Authorisation to Incur Election Expenses in a FC (other than the DC (second) FC) Election
- (iv) Notice of Adjustment of Authorised Amount of Election Expenses/Authorisation to Incur Election Expenses/Notice of Revocation of Authorisation to Incur Election Expenses by a List of Candidates in a GC/DC (second) FC or Notice of Revocation of Authorisation to Incur Election Expenses in a FC (other than the DC (second) FC) Election
- (v) Notice of Withdrawal of Candidature
- (vi) Notice of Appointment of Election Agent
- (vii) Notice of Appointment of Polling Agents for a Polling Station not Situated in a Prison
- (viii) Notice of Appointment of Polling Agent for a Dedicated Polling Station Situated in a Prison (other than a Maximum Security

Appendix A
(Page 4/20)

Prison) and Application for Consent to the Presence of Election Agent/Polling Agent in a Dedicated Polling Station Situated in a Prison (other than a Maximum Security Prison)

- (ix) Notice of Appointment of Counting Agents for a GC or Notice of Appointment of Counting Agents for DC (second) FC or Notice of Appointment of Counting Agents for a FC (other than the DC (second) FC)
- (x) Notice of Revocation of Appointment of Agent
- (xi) Information Sheet in relation to Election Advertisements
- (xii) Application for Creating an Account of the Central Platform and Undertaking in respect of the Terms and Conditions in Using the Central Platform for Candidates
- (xiii) Notification of the Electronic Address of the Candidate's Platform
- (xiv) Notification of Corrected Information in relation to Election Advertisements
- (xv) Consent of Support
- (xvi) Permission for Display of Election Advertisements or Conduct of Electioneering Activities at Private Premises
- (xvii) Declaration of Secrecy
- (xviii) Return of Election Deposit
- (xix) Advance Return and Declaration of

Appendix A
(Page 5/20)

Election Donations by a GC/DC (second) FC List of Candidates or Advance Return and Declaration of Election Donations by a FC (other than the DC (second) FC) Candidate

- (xx) Notice of Posting of Election Mail
(Attachment: Summary on Free Postage for Election Mail)

 - (xxi) Declaration for Posting of Election Mail

 - (xxii) Claim for Financial Assistance
(Attachment: Legislative Council Election Financial Assistance Scheme – Notes for Candidate and Independent Auditor of Candidate of Legislative Council Elections)

 - (xxiii) Notice of Withdrawal of Claim for Financial Assistance

 - (xxiv) Notice of Variation (Variation of the Claim for Financial Assistance)

 - (xxv) Notification of Decision on Electioneering Activities

 - (xxvi) Notification of the Intention to Hold a Public Meeting/Procession;
- (d) Notice for Collection of Electors' Information;
- (e) Undertaking on the Use of Electors' Information (Attachment: Supplementary Note on Undertaking on the Use of Electors' Information); and
- (f) Note for Submission of a Text Version of Introduction to Candidates for Persons with Visual Impairment.

5. Lodge with the RO a Notice of Withdrawal of Candidature if the candidate wishes to withdraw his/her candidature.
- Any time before, during or after handing in Nomination Form
6. (a) Ensure that all printed EAs, except for the category exempted, contain the name and address of the printer, date of printing and the number of copies printed.
- (b) Ensure that all prior written Consent of Support or Permission/Authorisation have been obtained before the publication of EAs and lodged with the RO (or CEO if RO has not yet been appointed), if applicable.
- (c) (i) If the candidates choose to post the electronic copy of EA and relevant information/documents onto the Candidate's Platform for public inspection, candidates should provide the CEO with the **electronic address** of the platform **at least 3 working days** (i.e. any day other than a general holiday or Saturday) **before publication of the first EA.**
- (ii) If the candidates choose to post the electronic copy of EA and relevant information/documents onto the Central Platform for public inspection, candidates should submit to the CEO the Application for Creating an Account of the Central Platform and Undertaking in respect of the Terms and Conditions in Using the Central Platform for Candidates.
- Candidates will receive the username and passwords from CEO **within 3 working days** upon receipt of the duly completed application and undertaking.
- (d) Make available a copy of each type of EAs and relevant information/documents for public inspection **within 1 working day** after publication by:

- (i) posting an electronic copy each of all his/her EAs and the relevant information/documents onto the Central Platform in accordance with the procedures set out in **Appendix E**;
- (ii) posting an electronic copy each of all his/her EAs and the relevant information/documents onto the Candidate's Platform and provide the CEO with the **electronic address** of the platform **at least 3 working days before publication of the first EA (For details, please see Appendix E)**;
- (iii) if it is technically impracticable to comply with (i) or (ii) above for EAs published through an open platform on the internet (such as when messages are sent through social networking or communication websites on the Internet like Twitter, Facebook, blogs, etc. and the exchanges are of an interactive and spontaneous nature), posting a hyperlink of such open platform and the information/documents relevant to the EAs onto the Candidate's Platform or the Central Platform in accordance with the procedures set out in **Appendix E**;
- (iv) providing 2 hardcopies each of the EAs (or 2 identical full colour photographs/printouts/photocopies of each EA which cannot be practically or conveniently produced in specie) and 1 hardcopy each of the relevant information/documents to the RO; or
- (v) providing 2 identical copies of a CD-ROM or DVD-ROM each containing the EAs and 1 hardcopy each of the relevant information/documents to the RO.

Candidates may make submission as required from time to time.

- | | | |
|--|-----|--|
| Any time before handing in Nomination Form till the end of election period | 7. | Submit to the CEO an Advance Return and Declaration of Election Donations when an election donation is received. |
| Any time after handing in Nomination Form | 8. | <p>Lodge with the RO (or CEO if RO has not yet been appointed) Authorisation to Incur Election Expenses.</p> <p>[For GC/DC (second) FC list of candidates, Declaration of Election Expenses Already Incurred/Cross-Authorisation and Authorisation to Incur Election Expenses by a List of Candidates in a GC/DC (second) FC Election is applicable.]</p> |
| Any time after handing in Nomination Form | 9. | Lodge with the RO a Notice of Appointment of Election Agent. |
| Any time after handing in Nomination Form, but before end of Nomination Period | 10. | <p>(a) If a candidate/list of candidates wishes to have his/her/their photograph(s) and election platform printed in the Introduction to Candidates, he/she/they should :</p> <p>(i) lodge with the RO a duly completed grid paper affixed with a colour photograph of the candidate which must be in specified size and taken within the last 6 months; and</p> <p>(ii) provide 2 additional copies of his/her photograph identical to the one affixed to the grid paper with his/her name label affixed on the back.</p> |

(If a candidate/list of candidates does not submit the grid paper, the Introduction to Candidates will only show the name of the candidate(s) and the number/alphabet of the candidate/list of the candidates. The statement, “Relevant information has not been provided by the candidate/list of candidates”, will also be printed in the space provided for the election platform.)

- (b) Lodge with the RO the form “Intention to Display Election Advertisements at Designated Spots”.
- (c) If a candidate wishes to have his/her photograph and particulars printed on a ballot paper, he/she should lodge with the RO:
- (i) a duly completed form of “Request by a Candidate for a Legislative Council Functional Constituency or a Sole Candidate on a Legislative Council Nomination List or by a Candidate for a District Council Constituency for Printing of Particulars Relating to the Candidate on a Ballot Paper” or a duly completed form of “Request by Candidates on a Legislative Council Nomination List with More than One Candidate for Printing of Particulars Relating to the Candidates on a Ballot Paper”, as the case may be;
 - (ii) a colour photograph of the candidate, in a specified size and taken within the last 6 months, which should be affixed to the form at (c)(i) above, and an additional copy of his/her photograph identical to the one affixed to the form with his/her name label affixed on the back; and
 - (iii) the duly completed form(s) of “Consent of a Prescribed Body for its Particulars to be Printed on a Ballot Paper in Relation to the Request by Candidate(s)”.

(If a candidate/list of candidate(s) does not submit the duly completed form(s) of request and consent, if any, specified above, only his/her/their name(s) and candidate/candidate list number/alphabet will be printed on a ballot paper.)

- Any time after handing in Nomination Form, but not later than 3 weeks before polling day
11. Make a request to the CEO for obtaining, **within 5 working days**, one set of mailing labels of electors and/or a Candidate Mailing Label System (“CMLS”) DVD-ROM containing information of electors in the constituency (Candidates or their election agents are required to submit an Undertaking on the Use of Electors’ Information with the request.).

(Note: To protect the environment, mailing labels of electors who have provided their email addresses for receiving EAs will not be provided by the CEO.)

- Any time after handing in Nomination Form, but not later than 7 days before polling day
12. Lodge with the CEO Notices of Appointment of Polling Agents for a Polling Station not Situated in a Prison.
13. Lodge with the RO Notices of Appointment of Counting Agents.
14. Lodge with the CEO the Notice of Appointment of Polling Agent for a Dedicated Polling Station Situated in a Prison (other than a Maximum Security Prison) and Application for Consent to the Presence of Election Agent/Polling Agent in a Dedicated Polling Station Situated in a Prison (other than a Maximum Security Prison).

(Note:(a) No consent will be given to the presence of an election agent at a dedicated polling station situated in a prison (other than a maximum security prison) if a polling agent has been appointed for that polling station. On the other hand, if consent has been given by the Commissioner of Correctional Services to the presence of an election agent at a dedicated polling station situated in a prison, no polling agent may be appointed for that polling station.

(b) No polling agent may be appointed nor may election agent be present at a dedicated polling station situated in a

maximum security prison.)

- | | |
|---|--|
| Around 3 days after end of Nomination Period | <p>15. Attend the briefing for candidates and collect from the RO the following:</p> <p style="margin-left: 40px;">(a) location maps and layout plans of the polling/ counting stations; and</p> <p style="margin-left: 40px;">(b) name badges for candidates and their agents.</p> <p>16. Attend meetings held by the RO to determine the candidate numbers/alphabets by drawing of lots and to allocate designated spots for display of EAs.</p> <p>17. Receive from the RO copy of the permission/ authorisation for display of EAs at designated spots allocated to the candidate (except for uncontested candidates who will not be allocated with designated spots).</p> |
| Around 7 days after end of Nomination Period | <p>18. Send by e-mail to e-intro_to_can@reo.gov.hk by the deadline specified by the REO the completed e-form of the text version of the Introduction to Candidates (available on website) for REO's uploading to the election dedicated website.</p> <p style="margin-left: 40px;">(If a candidate/list of candidates does not submit the file by the said deadline, only his/her/their name and candidate/candidate list number/alphabet and the words "Relevant information has not been provided by the candidate/list of candidates" will be shown in the appropriate area of the form.)</p> |
| Within 10 days after end of Nomination Period | <p>19. Receive from the RO information about the election agents appointed by other candidates of the same constituency.</p> |
| Around 14 days after end of Nomination Period | <p>20. Check the ballot paper printing proof and verify the particulars relating to the candidate to be printed on the ballot paper. If a candidate or his/her election agent cannot perform the checking in person, the candidate may authorise a representative in writing to check the</p> |

particulars concerned on the ballot paper printing proof on his/her behalf.

(If a candidate or his/her election agent/authorised representative does not perform the checking at the date and venue specified by the REO, the printing proof of the ballot paper will be printed without further notice.)

- | | | |
|--|-----|---|
| After end of
Nomination Period | 21. | Receive from the RO the notification on the validity of the candidate's nomination (which will also be sent to every other validly nominated candidate of the same constituency, if any). |
| Not later than 7 days
before polling day | 22. | Receive from the RO information regarding the delineation of no canvassing zones and no staying zones for the polling stations (including dedicated polling stations). |
| During the week before
the polling day | 23. | <p>Lodge with the CEO the Notice of Appointment of Polling Agent for a Dedicated Polling Station Situated in a Prison (other than a Maximum Security Prison) and Application for Consent to the Presence of Election/ Polling Agent in a Dedicated Polling Station Situated in a Prison (other than a Maximum Security Prison) only if –</p> <ul style="list-style-type: none"> (a) an elector imprisoned or held in custody who is entitled to vote for the relevant constituency at the aforesaid dedicated polling station situated in a prison is admitted or transferred to the prison during that week; and (b) the application is lodged without undue delay after the admission or transfer. |
| At least 2 clear working
days before posting
postage-free election
mail | 24. | Give notice of the date of the free posting of election mail by using the Notice of Posting of Election Mail (in duplicate), and present 3 unsealed election mail specimens to the relevant Manager (Retail Business) of Hongkong Post for inspection and approval. |

- | | | |
|--|-----|---|
| Make postage-free election mail before the posting deadline as designated by the Hongkong Post | 25. | Post postage-free election mail and present to the Hongkong Post a Declaration for Posting of Election Mail (in duplicate). Furnish a copy of the election mail for the attention of the manager(s) of the designated post offices/delivery offices for record purpose. |
| | | (Note: Election mail sent after the deadline may fail to reach the electors before the polling day.) |
| Within 2 working days after the polling day | 26. | Post the corrected information of the EAs concerned onto the Candidate's Platform or Central Platform alongside the original information and input the date of correction; or deposit with the RO a Notification of Corrected Information in relation to Election Advertisements. |
| Before entering the polling station, counting station or the ballot paper sorting station | 27. | Complete the Declarations of Secrecy (to be made by all candidates, their election agents, polling agents and counting agents). |
| Any time before polling day | 28. | Lodge with the CEO or RO, as the case may be, Notices of Revocation of Appointment of Agent, if any. |
| On polling day | 29. | Attend the poll and the count if so wishes, bringing along the Declaration of Secrecy. |
| | 30. | Candidates or their election agents personally deliver Notices of Appointment of Polling Agents for a Polling Station not Situated in a Prison and Notices of Revocation of Appointment of Agent to the relevant Presiding Officer ("PRO") other than a PRO of a dedicated polling station situated in a prison, if not yet lodged pursuant to paras. 12 and 28 respectively. |
| | 31. | Candidates or their election agents personally deliver Notices of Revocation of Appointment of Agent to the CEO to revoke the appointment of polling agent for a dedicated polling station situated in a prison, if not yet lodged pursuant to para. 28. |

32. Candidates or their election agents personally deliver Notices of Appointment of Counting Agents and Notices of Revocation of Appointment of Agent to the relevant PRO (or to the relevant RO if the counting agents are appointed for the central counting station), if not yet lodged pursuant to paras. 13 and 28 respectively.
- Within 10 days after polling day 33. Remove all EAs displayed on Government land/property.
- Within 2 weeks after polling day 34. Destroy or return to REO the CMLS DVD-ROM and unused mailing labels, if any. If a candidate/candidate(s) of a list has/have downloaded the electors' information from the CMLS for processing, he/she/they must also delete the information (use of data erasing software is recommended to completely erase the information).
- Before the expiry of the period of 60 days after the date on which the last of the following events occurs in relation to the election – 35. Lodge with the CEO an election return [See para. 4(c)(i)] signed by the candidate/all candidates of a list with invoices and receipts issued by recipients of the payments for all payments each of election expense of \$100 or above and duplicate donation receipts.
- (a) the result of the election is notified in the Gazette; 36. Eligible candidates/lists of candidates who wish to apply for financial assistance should complete a Claim for Financial Assistance. The completed form, together with the candidate's election return and an auditor's report should be presented in person by the candidate or his/her/their agent to the CEO.
- (b) the proceedings for the election are declared to have been terminated;
- (c) the election is declared to have failed.

Till the end of the period ending with the 60th day before the first anniversary of the date of the deadline for lodging the relevant election return (disregarding any order made by the CFI under s 40 of the ECICO)

37. Maintain the Candidate's Platform for public inspection of EAs and relevant information/documents.

Note:

Most of the forms mentioned in this checklist can be downloaded from the REO website at <http://www.reo.gov.hk>.

B. Handling and Declaring Election Expenses

Records Keeping

Before and After Nomination

1. Record all election expenses spent and all election donations received.
2. Keep the original invoices and receipts issued by recipients of the payment for expenses of \$100 or above.
3. Issue receipt for any non-anonymous donation of more than \$1,000 and keep a copy of the receipt. (The candidate/list of candidates may use the Standard Receipt for Election Donations provided by the REO.)
4.
 - (a) Keep records of the attachments posted onto the Candidate's Platform and maintain this platform till the end of the period ending with the 60th day before the first anniversary of the date of the deadline for lodging the relevant election return (disregarding any order made by the CFI under section 40 of the ECICO); or
 - (b) Keep records of the attachments posted onto the Central Platform; or

- (c) Keep copies of all relevant information/documents and EAs lodged with the RO.

***Appointment of
Election
Agents/Election
Expense Agents***

5. Each candidate/list of candidates can only appoint 1 election agent by completing a Notice of Appointment of Election Agent. An election agent has the authority to do everything a candidate is authorised to do under the EAC (EP) (LC) Reg for the purposes of the election, **except:**

(a) to sign the nomination form or make any requisite declaration and promissory oath in relation to a candidate's nomination;

(b) to withdraw the candidate's candidature;

(c) to incur election expenses unless he/she has been so authorised by the candidate;

(d) to authorise a person as an election expense agent to incur election expenses; and

(e) to be present in a dedicated polling station situated in a maximum security prison.

6. Each candidate/list of candidates can appoint 1 or more persons authorised to incur election expenses on his/her/their behalf, i.e. the election expense agents, by completing the Authorisations to Incur Election Expenses. A candidate/list of candidates **may** also authorise his/her/their election agent to incur election expenses for him/her/them. These agents may incur expenses only after the candidate/list of candidates has authorised them to do so. [After the formation of a GC or DC (second) FC list of candidates, each candidate on the list must also obtain the cross-authorisation from each other before they can incur any election expenses.]

***Lodging Authorisation
and Information Sheet
of Election***

7. Lodge with the RO the Notice of Appointment of Election Agent at any time after handing in Nomination Form.

***Advertisements with
the appropriate
authority and Posting
Election
Advertisements on
Central Platform or
Candidate's Platform***

8. Lodge with the RO (or CEO if the RO has not yet been appointed) the Authorisations to Incur Election Expenses or cross-authorisation of candidates on a GC or DC (second) FC list of candidates. The authorisation is not effective until it has been received by the RO or CEO (if the RO has not yet been appointed).
9. Make available a copy of each type of EAs and relevant information/documents for public inspection **within 1 working day** after publication by:
 - (a) posting an electronic copy each of all his/her EAs and the relevant information/documents onto the Central Platform in accordance with the procedures set out in **Appendix E**;
 - (b) posting an electronic copy each of all his/her EAs and the relevant information/documents onto the Candidate's Platform and provide the **electronic address** of the platform to the CEO **at least 3 working days before publication of the first EA (For details, please see Appendix E)**;
 - (c) if it is technically impracticable to comply with (a) or (b) above for EAs published through an open platform on the internet (such as when messages are sent through social networking or communication websites on the Internet like Twitter, Facebook, blogs, etc. and the exchanges are of an interactive and spontaneous nature), posting a hyperlink of such open platform on the Candidate's Platform or the Central Platform in accordance with the procedures set out in **Appendix E**;
 - (d) providing 2 hardcopies each of the EAs (or 2 identical full colour photographs/printouts/photocopies of each EA which cannot be practically or conveniently produced in specie) and 1 hardcopy each of the relevant information/documents to the RO; or

- (e) providing 2 identical copies of a CD-ROM or DVD-ROM each containing the EAs and 1 hardcopy each of the relevant information/documents to the RO.

Submission of Election Return

10. **A candidate/list of candidates must lodge his/her/their completed election return with the CEO before the expiry of the period of 60 days after the date on which the last of the following events occurs in relation to the election –**

- (a) **the result of the election is notified in the Gazette;**
- (b) **the proceedings for the election are declared to have been terminated;**
- (c) **the election is declared to have failed,**

or within such extended period as may be allowed by the Court of First Instance (“CFI”) under the relevant law.

11. The completed election return and a declaration verifying its contents must be submitted together with all supporting documents as required by s 37 of the ECICO. If financial assistance is to be claimed, the return and declaration must be audited by an auditor before submission and the auditor’s report must be attached to the submission.
12. The completed election return should include all election expenses incurred by the candidate/list of candidates, or by his/her/their election expense agents and also the removal cost for his/her/their EAs by Government Departments, if he/she/they has/have not removed all his/her/their EAs, and the election donations (including services and goods) received. All EAs submitted on the Information Sheet in relation to Election Advertisements, the Central Platform and the Candidate’s Platform should be included in the completed election return. ***A candidate/list of***

candidates is required to submit his/her/their election returns even if no election expenses have been incurred.

13. A candidate/all candidate(s) of a list must make the declaration/supplementary declaration(s) verifying the content of the election return before a Commissioner for Oaths (at District Offices) or a Justice of the Peace or a solicitor holding a practising certificate.
14. If a candidate/list of candidates is unable or has failed to lodge the election return by the deadline, he/she/they can apply to the CFI for an order allowing him/her/they to lodge the election return within such a further period as specified by the CFI.
15. If a candidate/list of candidates wishes to change any information in his/her/their submitted election return before the deadline, he/she/they may lodge with the CEO before the deadline a supplementary declaration stating the information to be changed.
16. If a candidate/list of candidates wishes to correct any error or false statement in his/her/their election return (including any document accompanying his/her/their election return) after the deadline, he/she/they must apply to the CFI for an order enabling him/her/they to do so. Notwithstanding this, if the aggregate value of any error or false statement found in the election return does not exceed the prescribed relief arrangement limit for election concerned for purposes of s 37A of the ECICO, the candidate/list of candidates may rectify the error or false statement in the election return in accordance with a simplified relief arrangement for minor errors or false statements as provided under s 37A of the ECICO within a specified period upon receipt of a notice from the CEO relating to the error and/or false statement (see paras. 16.29 to 16.34 of the Guidelines).

(This “Action Checklist for Candidates” is for general reference only. Candidates are advised to refer to the Action Checklist included in the candidate folder for the respective general election/by-election.)

[Amended in July 2008, January 2010 and, June 2012 and June 2016]

The Functional Constituencies and their Electors

<u>Item</u>	<u>Column 1 Constituency</u>	<u>Column 2 Electors</u>
1.	Heung Yee Kuk functional constituency	The Chairman and Vice-Chairmen of the Heung Yee Kuk and the Ex Officio, Special and Co-opted Councillors of the Full Council of the Kuk.
2.	Agriculture and fisheries functional constituency	<p>(1) Corporate members of each of the following bodies:</p> <p>(a) The Federation of Vegetable Marketing Co-operative Societies, Limited;</p> <p>(b) The Federation of Pig Raising Co-operative Societies of Hong Kong, Kowloon and New Territories, Limited;</p> <p>(c) The Joint Association of Hong Kong Fishermen;</p> <p>(d) Federation of Hong Kong Aquaculture Associations;</p> <p>(e) The Federation of Fishermen's Co-operative Societies of Shau Kei Wan District, Limited;</p> <p>(f) The Federation of Fishermen's Co-operative Societies of Tai Po District, N.T., Limited;</p> <p>(g) The Federation of Fishermen's Co-operative Societies of Sai Kung District, Limited;</p> <p>(h) The Federation of Fishermen's Co-operative Societies of Southern District, Limited.</p> <p>(2) Aberdeen Fishermen Friendship Association.</p> <p>(3) The Ap Lei Chau Fishermen's Credit Co-operative Society, Unlimited.</p> <p>(4) The Castle Peak Fishermen's Credit Co-operative Society, Unlimited.</p> <p>(5) The Castle Peak Mechanized Trawler Fishermen's Credit Co-operative Society, Unlimited.</p> <p>(6) Cheung Chau Fisheries Joint Association.</p> <p>(7) Cheung Chau Fishermen's Welfare Promotion Association.</p> <p>(8) The Fanling Kwun Ti Village Farmers' Irrigation Co-operative Society, Ltd.</p> <p>(9) Fish Farming and Stuff Association.</p> <p>(10) Fisherman's Association of Po Toi Island.</p> <p>(11) Fishery Development Association (Hong Kong) Limited.</p> <p>(12) Fraternal Association of The Floating Population of Hong Kong.</p> <p>(13) The Guild of Graziers.</p> <p>(14) Hang Hau Grazier Association.</p> <p>(15) Hong Kong and Kowloon Fishermen Association Ltd.</p> <p>(16) Hong Kong & Kowloon Floating Fishermen Welfare Promotion Association.</p> <p>(17) Hong Kong Fisheries Development Association.</p> <p>(18) Hong Kong Fishermen's Association.</p> <p>(19) Hong Kong Fishing Vessel Owners Association, Ltd.</p> <p>(20) Hong Kong Florists Association.</p>

<u>Item</u>	<u>Column 1</u> <u>Constituency</u>	<u>Column 2</u> <u>Electors</u>
2.	Agriculture and fisheries functional constituency (Cont'd)	<p>(21) Hong Kong Graziers Union.</p> <p>(22) Hong Kong Liner & Gill Netting Fisherman Association.</p> <p>(23) Hong Kong Livestock Industry Association.</p> <p>(24) Hong Kong N.T. Fish Culture Association.</p> <p>(25) Hong Kong N.T. Poultry (Geese & Ducks) Mutual Association.</p> <p>(26) Hong Kong Netting, Cultivation and Fisherman Association.</p> <p>(27) Hong Kong Off-shore Fishermen's Association.</p> <p>(28) The Lam Ti Agricultural Credit Co-operative Society, Limited.</p> <p>(29) Lamma Island Lo Dik Wan Aquaculture Association.</p> <p>(30) Lau Fau Shan Oyster Industry Association, New Territories.</p> <p>(31) Ma Wan Fisheries Rights Association Ltd.</p> <p>(32) The Mui Wo Agricultural Products Marketing & Credit Co-operative Society, Ltd.</p> <p>(33) Mui Wo Fishermen Fraternity Society.</p> <p>(34) N.T. Oyster and Aquatic Products United Association.</p> <p>(35) The New Territories Chicken Breeders Association, Ltd.</p> <p>(36) The New Territories Fishermen Fraternity Association Ltd.</p> <p>(37) New Territories Florist Association, Ltd.</p> <p>(38) North District Florists Association.</p> <p>(39) Outlying Islands Mariculture Association (Cheung Chau).</p> <p>(40) Peng Chau Fishermen Association Ltd.</p> <p>(41) Quality Broiler Development Association.</p> <p>(42) Sai Kung (North) Sham Wan Marine Fish Culture Business Association.</p> <p>(43) Sai Kung Po Toi O Fish Culture Business Association.</p> <p>(44) Sai Kung Tai Tau Chau Fish Culture Business Association.</p> <p>(45) Sai Kung Tai Wu Kok Fishermen's Association.</p> <p>(46) The Sha Tau Kok Marine Fish Culture Association.</p> <p>(47) The Sha Tau Kok Small Long Liner and Gill Net Fishermen's Credit Co-operative Society, Unlimited.</p> <p>(48) The Shan Tong Vegetable Marketing Co-operative Society, Ltd.</p> <p>(49) Shatin Ah Kung Kok Fishermen Welfare Association.</p> <p>(50) Shatin Florists Association.</p> <p>(51) The Shau Kei Wan Deep Sea Capture Fishermen's Credit Co-operative Society, Unlimited.</p> <p>(52) Shau Kei Wan Fishermen Friendship Association.</p> <p>(53) The Shau Kei Wan Pair Trawler Fishermen's Credit Co-operative Society, Unlimited.</p> <p>(54) The Shau Kei Wan Trawler Fishermen's Credit Co-operative Society, Unlimited.</p>

<u>Item</u>	<u>Column 1</u> <u>Constituency</u>	<u>Column 2</u> <u>Electors</u>
2.	Agriculture and fisheries functional constituency (Cont'd)	(55) Tai O Fishermen (Coastal Fishery) Association.
		(56) The Tai O Sha Chai Min Fishermen's Credit Co-operative Society, Unlimited.
		(57) The Tai Po Fishermen's Credit Co-operative Society, Unlimited.
		(58) Tai Po Florists and Horticulturists Association.
		(59) The Tai Po Purse Seiner and Small Long Liner Fishermen's Credit Co-operative Society, Unlimited.
		(60) The Tsing Lung Tau Hand Liner Fishermen's Credit Co-operative Society, Unlimited.
		(61) The Tsuen Wan Fishermen's Credit Co-operative Society, Unlimited.
		(62) The Tuen Mun Mechanized Fishing Boat Fishermen's Credit Co-operative Society, Unlimited.
		(63) Tuen Mun Agricultural Association.
		(64) Tung Lung Chau Mariculture Association.
		(65) The Hong Kong Branch of the World's Poultry Science Association.
		(66) Yuen Long Agriculture Productivity Association.
		(67) Yung Shue Au Marine Fish Culture Business Association.
		(68) Tsing Yi Residents Association.
		(69) 荃灣葵青居民聯會（漁民組）.
(70) 荃灣葵青漁民會.		
(71) The Shau Kei Wan Stern Trawler Fishermen's Credit Co-operative Society, Unlimited.		
(72) Sustainable Ecological Ethical Development Foundation Limited.		
(73) N. T. North District Fishermen's Association.		
(74) Tai Po Off Shore Fishermen's Association.		
(75) Aberdeen Fisherwomen Association.		
3.	Insurance functional constituency	Bodies that are insurers authorized or deemed to be authorized under the Insurance Companies Ordinance (Cap 41).
4.	Transport functional constituency	(1) Parking Management and Consultancy Services Limited.
		(2) Airport Authority Hong Kong.
		(3) Hong Kong Driver's Training Association.
		(4) The Association of N.T. Radio Taxicabs Ltd.
		(5) Autotoll Limited.
		(6) The Chartered Institute of Logistics and Transport in Hong Kong.
		(7) China Merchants Shipping & Enterprises Co. Ltd.
		(8) Chu Kong Shipping Enterprises (Holdings) Co. Ltd.
		(9) Chuen Kee Ferry Ltd.
		(10) Chuen Lee Radio Taxis Association Ltd.
		(11) Citybus Ltd.

<u>Item</u>	<u>Column 1</u> <u>Constituency</u>	<u>Column 2</u> <u>Electors</u>
4.	Transport functional constituency (Cont'd)	(12) Coral Sea Ferry Service Co., Ltd. (13) COSCO–HIT Terminals (Hong Kong) Limited. (14) CTOD Association Company Ltd. (15) Turbojet Ferry Services (Guangzhou) Limited. (16) Discovery Bay Transportation Services Ltd. (17) Driving Instructors Merchants Association, Limited. (18) Eastern Ferry Co. (19) Expert Fortune Ltd. (20) Far East Hydrofoil Co. Ltd. (21) Fat Kee Stevedores Ltd. (22) The Fraternity Association of N.T. Taxi Merchants. (23) Fraternity Taxi Owners Association. (24) G.M.B. Maxicab Operators General Association Ltd. (25) The Goods Vehicle Fleet Owners Association Ltd. (26) Happy Taxi Operator's Association Ltd. (27) Hoi Kong Container Services Co. Ltd. (28) Hon Wah Public Light Bus Association Ltd. (29) Hong Kong Air Cargo Terminals Limited. (30) Hong Kong & Kowloon Ferry Ltd. (31) Hong Kong Kowloon Goods Vehicles, Omnibuses and Minibuses Instructors Association Limited. (32) Hong Kong & Kowloon Motor Boats & Tug Boats Association Limited. (33) Hong Kong & Kowloon Radio Car Owners Association Ltd. (34) Hong Kong and Kowloon Rich Radio Car Service Centre Association Ltd. (35) HongKong Association of Freight Forwarding and Logistics Limited. (36) Hong Kong Automobile Association. (37) The Hong Kong Cargo–Vessel Traders' Association Ltd. (38) Hong Kong Commercial Vehicle Driving Instructors Association. (39) Hong Kong CFS and Logistics Association Limited. (40) Hong Kong Container Tractor Owner Association Ltd. (41) Hong Kong Driving Instructors' Association. (42) Hong Kong Guangdong Transportation Association Ltd. (43) The Hong Kong Institute of Marine Technology. (44) Hong Kong, Kowloon & NT Public & Maxicab Light Bus Merchants' United Association. (45) Hong Kong Taxi Owners' Association Limited. (46) The Hong Kong Liner Shipping Association. (47) Hong Kong Marine Contractors Association. (48) Hong Kong Motor Car Driving Instructors Association Ltd. (49) Hong Kong Pilots Association Ltd. (50) Hong Kong Public & Maxicab Light Bus United Associations.

<u>Item</u>	<u>Column 1</u> <u>Constituency</u>	<u>Column 2</u> <u>Electors</u>
4.	Transport functional constituency (Cont'd)	<p>(51) Hong Kong Public Cargo Working Areas Traders Association Ltd.</p> <p>(52) Hong Kong Scheduled (GMB) Licensee Association.</p> <p>(53) The Hong Kong School of Motoring Ltd.</p> <p>(54) Hong Kong Sea Transport and Logistics Association Limited.</p> <p>(55) The Hong Kong Shipowners Association Ltd.</p> <p>(56) Hong Kong Shipping Circles Association Ltd.</p> <p>(57) Hong Kong Shipping Industry Institute.</p> <p>(58) Hong Kong Logistics Management Staff Association.</p> <p>(59) Hong Kong Society of Articulated Vehicle Driving Instructors Ltd.</p> <p>(60) The Hong Kong Stevedores Employers' Association.</p> <p>(61) Hong Kong Tele-call Taxi Association.</p> <p>(62) Hong Kong Tramways, Limited.</p> <p>(63) Hong Kong Transportation Warehouse Wharf Club.</p> <p>(64) The Hongkong & Yaumati Ferry Co., Ltd.</p> <p>(65) Hongkong International Terminals Ltd.</p> <p>(66) Institute of Advanced Motorists (Hong Kong) Limited.</p> <p>(67) Institute of Seatransport.</p> <p>(68) Institute of Transport Administration (Hong Kong, China).</p> <p>(69) Kowloon Fung Wong Public Light Bus Merchants & Workers' Association Ltd.</p> <p>(70) The Kowloon Motor Bus Company (1933) Limited.</p> <p>(71) Kowloon Motor Driving Instructors' Association Ltd.</p> <p>(72) The Kowloon PLB Chiu Chow Traders & Workers Friendly Association.</p> <p>(73) The Kowloon Taxi Owners Association Ltd.</p> <p>(74) Kowloon Truck Merchants Association Ltd.</p> <p>(75) Kwik Park Limited.</p> <p>(76) Lam Tin Wai Hoi Public Light Bus Association.</p> <p>(77) Lantau Taxi Association.</p> <p>(78) Lei Yue Mun Ko Chiu Road Public Light Bus Merchants Association Ltd.</p> <p>(79) Lok Ma Chau China-Hong Kong Freight Association.</p> <p>(80) Long Win Bus Company Limited.</p> <p>(81) Mack & Co. Carpark Management Limited.</p> <p>(82) Marine Excursion Association Limited.</p> <p>(83) Maritime Affairs Research Association Ltd.</p> <p>(84) MTR Corporation Limited.</p> <p>(85) Merchant Navy Officers' Guild-Hong Kong.</p> <p>(86) Metropark Limited.</p> <p>(87) Mid-stream Holdings (HK) Limited.</p> <p>(88) Mixer Truck Drivers Association.</p> <p>(89) Modern Terminals Ltd.</p> <p>(90) N.T. PLB Owners Association.</p> <p>(91) N.T. San Tin PLB (17) Owners Association.</p>

<u>Item</u>	<u>Column 1</u> <u>Constituency</u>	<u>Column 2</u> <u>Electors</u>
4.	Transport functional constituency (Cont'd)	(92) N.T. Taxi Merchants Association Ltd. (93) N.T. Taxi Owners & Drivers Fraternal Association. (94) N.T. Taxi Radio Service General Association. (95) N.W. Area Taxi Drivers & Operators Association. (96) New Hong Kong Tunnel Co., Ltd. (97) New Lantao Bus Co., (1973) Ltd. (98) New Territories Cargo Transport Association Ltd. (99) New World First Bus Services Limited. (100) North District Taxi Merchants Association. (101) Organisation of Hong Kong Drivers. (102) Peak Tramways Co., Ltd. (103) Public and Private Light Buses Driving Instructors' Society. (104) The Public Cargo Area Trade Association. (105) Public Light Bus General Association. (106) The Public Omnibus Operators Association Ltd. (107) Public Vehicle Merchants Fraternity Association. (108) Quadripartite Taxi Service Association Ltd. (109) River Trade Terminal Co. Ltd. (110) Route 3 (CPS) Company Limited. (111) Sai Kung Public Light Bus Drivers and Owners Association. (112) Sai Kung Taxi Operators Association Ltd. (113) CSX World Terminals Hong Kong Limited. (114) Serco Group (HK) Limited. (115) The "Star" Ferry Co., Ltd. (116) Sun Hing Taxi Radio Association. (117) Taxi Association Limited. (118) Tate's Cairn Tunnel Company Limited. (119) Taxi Associations Federation. (120) Taxi Dealers & Owners Association Ltd. (121) The Taxi Operators Association Ltd. (122) Taxicom Vehicle Owners Association Ltd. (123) Transport Infrastructure Management Limited. (124) Tsuen Wan PLB Commercial Association Ltd. (125) Tuen Mun Public Light Bus Association. (126) Tung Yee Shipbuilding and Repairing Merchants General Association Limited. (127) United Friendship Taxi Owners & Drivers Association Ltd. (128) Wai Fat Taxi Owners Association Ltd. (129) Wai Yik H.K. & Kowloon and New Territories Taxi Owners Association. (130) West Coast International (Parking) Limited. (131) Western Harbour Tunnel Co. Ltd. (132) Wilson Parking (Hong Kong) Limited. (133) Wing Lee Radio Car Traders Association Ltd. (134) Wing Tai Car Owners & Drivers Association Ltd.

<u>Item</u>	<u>Column 1</u> <u>Constituency</u>	<u>Column 2</u> <u>Electors</u>
4.	Transport functional constituency (Cont'd)	(135) Wu Gang Shipping Co. Ltd. (136) Xiamen United Enterprises (H.K.) Ltd. (137) School Buses Operators Association Limited. (138) New World First Ferry Services Limited. (139) Shun Tak–China Travel Macau Ferries Limited. (140) Hong Kong Container Drayage Services Association Limited. (141) Hong Kong Kowloon & N.T. Grab – Mounted Lorries Association Limited. (142) Hong Kong Waste Disposal Industry Association. (143) HK Public – light Bus Owner & Driver Association. (144) Logistics Industry & Container Truck Drivers Union. (145) The Concrete Producers Association of Hong Kong Limited. (146) Hongkong Guangdong Boundary Crossing Bus Association Limited. (147) Tsui Wah Ferry Service Company Limited. (148) Quality Driver Training Centre Limited. (149) Public and Private Commercial Driving Instructors' Society. (150) Shun Tak – China Travel Ship Management Limited. (151) Cruise Ferries (HK) Limited. (152) Asia Airfreight Terminal Company Limited. (153) The Hong Kong Joint Branch of The Royal Institution of Naval Architects and The Institute of Marine Engineering, Science and Technology. (154) The Hongkong Salvage & Towing Company Limited. (155) The Institute of Chartered Shipbrokers, Hong Kong Branch. (156) Hongkong United Dockyards Limited. (157) Guangdong and Hong Kong Feeder Association Limited. (158) Hong Kong Right Hand Drive Motors Association Limited. (159) The Institute of the Motor Industry Hong Kong. (160) Hong Kong Vehicle Repair Merchants Association Limited. (161) Environmental Vehicle Repairers Association Limited. (162) The Hong Kong Taxi and Public Light Bus Association Limited. (163) Park Island Transport Company Limited. (164) Discovery Bay Road Tunnel Company Limited. (165) International Association of Transport Officers. (166) Hong Kong Express Airways Limited. (167) Hong Kong (Cross Border) Transportation Drivers' Association. (168) Hong Kong Logistics Association Limited. (169) Hong Kong Container Depot and Repairer Association

<u>Item</u>	<u>Column 1</u> <u>Constituency</u>	<u>Column 2</u> <u>Electors</u>
4.	Transport functional constituency (Cont'd)	Limited. (170) New World Parking Management Limited. (171) The Nautical Institute – Hong Kong Branch. (172) Worldwide Flight Services, Inc. (173) NT Taxi Operations Union. (174) Sun Star Taxi Operators Association. (175) Taxi & P.L.B. Concern Group. (176) Tai Wo Motors Limited. (177) Tuen Mun District Tourists and Passengers Omnibus Operators Association Limited. (178) Tsuen Wan District Tourists and Passengers Omnibus Operators Association Limited. (179) Yuen Long District Tourists and Passengers Omnibus Operators Association Limited. (180) Kowloon District Tourists and Passengers Omnibus Operators Association Limited. (181) Hong Kong District Tourists and Passengers Omnibus Operators Association Limited. (182) Sino Parking Services Limited. (183) Urban Parking Limited. (184) Greater Lucky (HK) Company Limited. (185) China Hongkong and Macau Boundary Crossing Bus Association Limited. (186) Ground Support Engineering Limited. (187) Cathay Pacific Services Limited. (188) Cathay Pacific Catering Services (H.K.) Limited. (189) LSG Lufthansa Service Hong Kong Limited. (190) Gate Gourmet Hong Kong, Limited. (191) ECO Aviation Fuel Services Limited. (192) Hong Kong Aircraft Engineering Company Limited. (193) China Aircraft Services Limited. (194) Dah Chong Hong – Dragonair Airport GSE Service Limited. (195) Jardine Air Terminal Services Limited. (196) Service Managers Association. (197) Driving Instructors Association. (198) The Chamber of Hong Kong Logistics Industry Limited. (199) New Horizon School of Motoring Limited. (200) Leinam School of Motoring Limited. (201) TIML MOM Limited. (202) Hong Kong Taxi Association.
5.	Education functional constituency	(1) Full-time academic staff engaged in teaching or research and administrative staff of equivalent rank in – (a) institutions of higher education funded through the University Grants Committee; (b) approved post secondary colleges registered under the Post Secondary Colleges Ordinance (Cap 320);

<u>Item</u>	<u>Column 1</u> <u>Constituency</u>	<u>Column 2</u> <u>Electors</u>
5.	Education functional constituency (Cont'd)	<ul style="list-style-type: none"> (c) technical colleges established under the Vocational Training Council Ordinance (Cap 1130); (d) The Hong Kong Academy for Performing Arts; (e) The Open University of Hong Kong.
	(2)	<p>Full – time academic staff engaged in teaching or research and administrative staff of equivalent rank in the institutions which –</p> <ul style="list-style-type: none"> (a) offer post secondary education leading to the award of any qualification entered into the Qualifications Register established under the Accreditation of Academic and Vocational Qualifications Ordinance (Cap 592); and (b) are set up by– <ul style="list-style-type: none"> (i) an institution of higher education funded through the University Grants Committee; (ii) The Hong Kong Academy for Performing Arts; or (iii) The Open University of Hong Kong.
	(3)	<p>Members of each of the following bodies –</p> <ul style="list-style-type: none"> (a) Council of the University of Hong Kong; (b) Council of The Chinese University of Hong Kong; (c) Council of The Hong Kong University of Science and Technology; (d) Council of the City University of Hong Kong; (e) Council of The Hong Kong Polytechnic University; (f) Council of The Hong Kong Academy for Performing Arts; (g) Council of The Open University of Hong Kong; (h) the Vocational Training Council; (i) Council of The Education University of Hong Kong; (j) Council of the Hong Kong Baptist University; (k) Council of Lingnan University; (l) Board of Governors of the Hong Kong Shue Yan University; (m) Board of Governors of the Caritas Institute of Higher Education; (n) Board of Governors of the Chu Hai College of Higher Education; (o) Board of Governors of the Centennial College; (p) Board of Governors of the Tung Wah College; (q) Board of Governors of the Hang Seng Management College; (r) Board of Governors of the Hong Kong Nang Yan College of Higher Education; (s) Board of Governors of the HKCT Institute of Higher Education; (t) Board of Governors of the Gratia Christian College.
	(4)	<p>Registered teachers registered under the Education</p>

<u>Item</u>	<u>Column 1</u> <u>Constituency</u>	<u>Column 2</u> <u>Electors</u>
5.	Education functional constituency (<i>Cont'd</i>)	<p>Ordinance (Cap 279).</p> <p>(5) Permitted teachers engaged in full-time employment in schools registered or provisionally registered under the Education Ordinance (Cap 279).</p> <p>(6) Teachers and principals of schools entirely maintained and controlled by the Government.</p> <p>(7) Persons whose principal or only employment is that of full-time teaching with the following institutions—</p> <p>(a) technical institutes, industrial training centres or skills centres established under the Vocational Training Council Ordinance (Cap 1130);</p> <p>(b) (i) industrial training centres established under the repealed Industrial Training (Construction Industry) Ordinance (Cap 317) and maintained under the Construction Industry Council Ordinance (Cap 587);</p> <p>(ii) industrial training centres established under the Construction Industry Council Ordinance (Cap 587);</p> <p>(c) industrial training centres established under the Industrial Training (Clothing Industry) Ordinance (Cap 318);</p> <p>(d) Hong Chi Association-Hong Chi Pinehill Integrated Vocational Training Centre;</p> <p>(e) Caritas Lok Mo Integrated Vocational Training Centre of Caritas-Hong Kong incorporated under the Caritas-Hong Kong Incorporation Ordinance (Cap 1092).</p> <p>(8) Registered managers of schools registered under the Education Ordinance (Cap 279).</p>
6.	Legal functional constituency	<p>(1) Members of The Law Society of Hong Kong entitled to vote at general meetings of the Society.</p> <p>(2) Members of the Hong Kong Bar Association entitled to vote at general meetings of the Association.</p> <p>(3) Legal officers within the meaning of the Legal Officers Ordinance (Cap 87).</p> <p>(4) Persons appointed under section 3 of the Legal Aid Ordinance (Cap 91).</p> <p>(5) Persons deemed to be legal officers for the purpose of the Legal Officers Ordinance (Cap 87) by section 75(3) of the Bankruptcy Ordinance (Cap 6) or section 3(3) of the Director of Intellectual Property (Establishment) Ordinance (Cap 412).</p> <p>(6) The Legal Adviser of the Legislative Council Secretariat and his or her assistants who are in the full-time employment of The Legislative Council Commission and are barristers or solicitors as defined in the Legal</p>

<u>Item</u>	<u>Column 1</u> <u>Constituency</u>	<u>Column 2</u> <u>Electors</u>
6.	Legal functional constituency (<i>Cont'd</i>)	Practitioners Ordinance (Cap 159).
7.	Accountancy functional constituency	Certified public accountants registered under the Professional Accountants Ordinance (Cap 50).
8.	Medical functional constituency	(1) Medical practitioners registered or deemed to be registered under the Medical Registration Ordinance (Cap 161). (2) Dentists registered, deemed to be registered or exempt from registration under the Dentists Registration Ordinance (Cap 156).
9.	Health services functional constituency	(1) Chiropractors registered under the Chiropractors Registration Ordinance (Cap 428). (2) Nurses registered or enrolled or deemed to be registered or enrolled under the Nurses Registration Ordinance (Cap 164). (3) Midwives registered or deemed to be registered under the Midwives Registration Ordinance (Cap 162). (4) Pharmacists registered under the Pharmacy and Poisons Ordinance (Cap 138). (5) Medical laboratory technologists registered under the Medical Laboratory Technologists (Registration and Disciplinary Procedure) Regulations (Cap 359 sub. leg. A). (6) Radiographers registered under the Radiographers (Registration and Disciplinary Procedure) Regulation (Cap 359 sub. leg. H). (7) Physiotherapists registered under the Physiotherapists (Registration and Disciplinary Procedure) Regulation (Cap 359 sub. leg. J). (8) Occupational therapists registered under the Occupational Therapists (Registration and Disciplinary Procedure) Regulations (Cap 359 sub. leg. B). (9) Optometrists registered under the Optometrists (Registration and Disciplinary Procedure) Regulation (Cap 359 sub. leg. F). (10) Dental hygienists enrolled under the Ancillary Dental Workers (Dental Hygienists) Regulations (Cap 156 sub. leg. B). (11) Audiologists, audiology technicians, chiropodists (also known as "podiatrists"), dental surgery assistants, dental technicians, dental technologists, dental therapists, dietitians, dispensers, mould laboratory technicians,

<u>Item</u>	<u>Column 1</u> <u>Constituency</u>	<u>Column 2</u> <u>Electors</u>
9.	Health services functional constituency (Cont'd)	<p>orthoptists, clinical psychologists, educational psychologists, prosthetists, speech therapists and scientific officers (medical) who are in the service under the Government, or are employed in Hong Kong, at the following institutions–</p> <p>(a) Public hospitals within the meaning of the Hospital Authority Ordinance (Cap 113);</p> <p>(b) Hospitals registered under the Hospitals, Nursing Homes and Maternity Homes Registration Ordinance (Cap 165);</p> <p>(c) Clinics maintained or controlled by the Government or The Chinese University of Hong Kong or by the University of Hong Kong;</p> <p>(d) Services subvented by the Government.</p>
10.	Engineering functional constituency	<p>(1) Professional engineers registered under the Engineers Registration Ordinance (Cap 409).</p> <p>(2) Members of the Hong Kong Institution of Engineers entitled to vote at general meetings of the Institution.</p>
11.	Architectural, surveying, planning and landscape functional constituency	<p>(1) Architects registered under the Architects Registration Ordinance (Cap 408).</p> <p>(2) Members of The Hong Kong Institute of Architects entitled to vote at general meetings of the Institute.</p> <p>(3) Landscape architects registered under the Landscape Architects Registration Ordinance (Cap 516).</p> <p>(4) Members of The Hong Kong Institute of Landscape Architects entitled to vote at general meetings of the Institute.</p> <p>(5) Professional surveyors registered under the Surveyors Registration Ordinance (Cap 417).</p> <p>(6) Members of The Hong Kong Institute of Surveyors entitled to vote at general meetings of the Institute.</p> <p>(7) Professional planners registered under the Planners Registration Ordinance (Cap 418).</p> <p>(8) Members of The Hong Kong Institute of Planners entitled to vote at general meetings of the Institute.</p>
12.	Labour functional constituency	Bodies that are trade unions registered under the Trade Unions Ordinance (Cap 332) of which all the voting members are employees.
13.	Social welfare functional constituency	Social workers registered under the Social Workers Registration Ordinance (Cap 505).

<u>Item</u>	<u>Column 1</u> <u>Constituency</u>	<u>Column 2</u> <u>Electors</u>
14.	Real estate and construction functional constituency	<p>(1) Members of The Real Estate Developers Association of Hong Kong entitled to vote at general meetings of the Association.</p> <p>(2) Members of The Hong Kong Construction Association, Limited entitled to vote at general meetings of the Association.</p> <p>(3) Members of The Hong Kong E&M Contractors' Association Limited entitled to vote at general meetings of the Association.</p>
15.	Tourism functional constituency	<p>Bodies that are:</p> <p>(1) travel industry members of the body known immediately before 1 April 2001 as the Hong Kong Tourist Association, entitled immediately before that date, under the constitution of that body in force immediately before that date, to vote at general meetings of that body.</p> <p>(2) members of the Travel Industry Council of Hong Kong entitled to vote at general meetings of the Council.</p> <p>(3) members of The Board of Airline Representatives in Hong Kong.</p> <p>(4) members of the Hong Kong Hotels Association entitled to vote at general meetings of the Association.</p> <p>(5) members of Federation of Hong Kong Hotel Owners Limited entitled to vote at general meetings of the Federation.</p>
16.	Commercial (first) functional constituency	Bodies that are members of The Hong Kong General Chamber of Commerce entitled to vote at general meetings of the Chamber.
17.	Commercial (second) functional constituency	Members of The Chinese General Chamber of Commerce entitled to vote at general meetings of the Chamber.
18.	Industrial (first) functional constituency	Members of the Federation of Hong Kong Industries entitled to vote at general meetings of the Federation.
19.	Industrial (second) functional constituency	Bodies that are members of The Chinese Manufacturers' Association of Hong Kong entitled to vote at general meetings of the Association.
20.	Finance functional constituency	<p>Bodies that are:</p> <p>(1) banks within the meaning of the Banking Ordinance (Cap 155).</p> <p>(2) restricted licence banks within the meaning of the Banking Ordinance (Cap 155).</p>

<u>Item</u>	<u>Column 1</u> <u>Constituency</u>	<u>Column 2</u> <u>Electors</u>
20.	Finance functional constituency (<i>Cont'd</i>)	(3) deposit-taking companies within the meaning of the Banking Ordinance (Cap 155).
21.	Financial services functional constituency	(1) Exchange participants of a recognized exchange company. (2) Members of The Chinese Gold & Silver Exchange Society entitled to vote at general meetings of the Society.
22.	Sports, performing arts, culture and publication functional constituency	(1) Statutory bodies and registered bodies (other than schools registered under the Education Ordinance (Cap 279) and bodies formed by such schools) that are members of the sports associations affiliated to the Sports Federation & Olympic Committee of Hong Kong, China. (2) Sports associations affiliated to the Sports Federation & Olympic Committee of Hong Kong, China but have no statutory bodies or registered bodies as members. (3) The following district sports associations: (a) Central & Western District Recreation & Sports Association; (b) Eastern District Recreation & Sports Advancement Association Ltd.; (c) The Federation of Tsuen Wan District Sports & Recreation Association Ltd.; (d) Islands District Sports Association; (e) Kowloon City District Recreation & Sports Council Limited; (f) Kwai Tsing District Sports Association Limited; (g) Kwun Tong Sports Promotion Association Ltd.; (h) Mong Kok District Cultural, Recreational and Sports Association Limited; (i) North District Sports Association Limited; (j) Sai Kung District Sports Association Ltd.; (k) Sha Tin Sports Association Ltd.; (l) Sham Shui Po Sports Association Limited; (m) Southern District Recreation and Sports Association Limited; (n) Tai Po Sports Association Ltd.; (o) Tuen Mun Sports Association Limited; (p) Wan Chai District Arts Cultural Recreational and Sports Association Limited; (q) Wong Tai Sin District Recreation & Sports Council; (r) Yaumatei and Tsimshatsui Recreation & Sports Association Ltd.; (s) Yuen Long District Sports Association Ltd. (4) Bodies listed in a Gazette notice currently in force made

<u>Item</u>	<u>Column 1</u> <u>Constituency</u>	<u>Column 2</u> <u>Electors</u>
22.	Sports, performing arts, culture and publication functional constituency (Cont'd)	<p>under section 3(5) of the Hong Kong Arts Development Council Ordinance (Cap 472) as organizations for the purpose of section 3(4) of that Ordinance.</p> <p>(5) Statutory bodies and registered bodies, the primary goal of which is the promotion of arts, and to which grants, sponsorship or performance fees have been approved by the Hong Kong Arts Development Council, the Urban Council, the Regional Council, the Provisional Urban Council, the Provisional Regional Council, the Leisure and Cultural Services Department or the Home Affairs Bureau during the relevant period.</p> <p>(6) The following district arts and culture associations:</p> <ul style="list-style-type: none"> (a) Central and Western District Association for Culture and Arts; (b) Eastern District Arts Council Limited; (c) Kowloon City District Arts and Culture Council; (d) Kwai Chung and Tsing Yi District Culture and Arts Co-ordinating Association Limited; (e) Kwun Tong District Culture and Recreation Promotion Association; (f) North District Arts Advancement Association Limited; (g) Sai Kung Culture & Recreational Advancement Association; (h) Sha Tin Arts Association Limited; (i) Sham Shui Po Arts Association Limited; (j) Southern District Arts and Culture Association Limited; (k) Tai Po District Arts Advancement Association; (l) Tsuen Wan Culture & Recreation Co-ordinating Association Limited; (m) Tuen Mun Arts Promotion Association; (n) Wong Tai Sin District Arts Council; (o) Yau Ma Tei and Tsim Sha Tsui Culture and Arts Association Limited; (p) Yuen Long District Arts Committee. <p>(7) Members of each of the following bodies entitled to vote at general meetings of the body–</p> <ul style="list-style-type: none"> (a) Educational Booksellers' Association, Limited; (b) The Hong Kong Publishers and Distributors Association; (c) Hong Kong Book & Magazine Trade Association Limited; (d) Hongkong Book and Stationery Industry Association Company Limited; (e) The Hong Kong Association of Professional Education Publishing Limited. <p>(8) Members of the Hong Kong Publishing Federation</p>

<u>Item</u>	<u>Column 1</u> <u>Constituency</u>	<u>Column 2</u> <u>Electors</u>
22.	Sports, performing arts, culture and publication functional constituency <i>(Cont'd)</i>	<p>Limited (other than those referred to in para. (7)) entitled to vote at general meetings of the Federation.</p> <p>Members of each of the following bodies entitled to vote at general meetings of the body–</p> <p>(a) Hong Kong Motion Picture Industry Association Limited;</p> <p>(b) Hong Kong Film Awards Association Ltd.;</p> <p>(c) International Federation of the Phonographic Industry (Hong Kong Group) Limited;</p> <p>(d) Movie Producers and Distributors Association of Hong Kong Ltd.;</p> <p>(e) Music Publishers Association of Hong Kong Ltd.;</p> <p>(f) Hong Kong Theatres Association Ltd.;</p> <p>(g) Hong Kong Recording Industry Alliance Limited.</p> <p>(10) Corporate proprietors, the principal business of which is publication, registered under the Registration of Local Newspapers Ordinance (Cap 268).</p> <p>(11) Corporate proprietors of newspaper distributors licensed under the Newspapers Registration and Distribution Regulations (Cap 268 sub. leg. B).</p> <p>(12) Bodies that are holders of one or more of the following classes of licences granted under the Broadcasting Ordinance (Cap 562)–</p> <p>(a) licences to provide a domestic free television programme service;</p> <p>(b) licences to provide a domestic pay television programme service;</p> <p>(c) licences to provide a non – domestic television programme service.</p> <p>(13) Holders of licences granted under Part 3A of the Telecommunications Ordinance (Cap 106) (sound broadcasting licences).</p> <p>(14) All Stars Sports Association Ltd.</p> <p>(15) The Song Writers' Association of Hong Kong.</p> <p>(16) Artiste Training Alumni Association Limited.</p> <p>(17) Composers and Authors Society of Hong Kong Limited.</p> <p>(18) Friends of the Art Museum, The Chinese University of Hong Kong Limited.</p> <p>(19) The Friends of the Hong Kong Museum of Art.</p> <p>(20) Hong Kong Film Directors' Guild Limited.</p> <p>(21) Hong Kong Anthropological Society.</p> <p>(22) Hong Kong Archaeological Society.</p> <p>(23) The Hong Kong Children's Choir.</p> <p>(24) Hong Kong Chinese Orchestra Limited.</p> <p>(25) Hong Kong Chinese Press Association.</p> <p>(26) Hong Kong & Macau Cinema and Theatrical Enterprise Association Limited.</p> <p>(27) Hong Kong Cinematography Lighting Association</p>

<u>Item</u>	<u>Column 1</u> <u>Constituency</u>	<u>Column 2</u> <u>Electors</u>
22.	Sports, performing arts, culture and publication functional constituency (Cont'd)	Limited. (28) Hong Kong Curators Association. (29) Hong Kong Dance Company Limited. (30) Hong Kong Federation of Journalists Ltd. (31) Hong Kong Festival Fringe Limited. (32) Hong Kong Film Academy. (33) Hong Kong Film Arts Association Limited. (34) Hong Kong History Society. (35) The Hong Kong Intellectual Property Society Limited. (36) Hong Kong Journalists Association. (37) Hong Kong Museum of Medical Sciences Society. (38) Hong Kong News Executives' Association, Limited. (39) Hong Kong P.E.N. (English) Centre. (40) Hong Kong Performing Artistes Guild Limited. (41) Hong Kong Philharmonic Orchestra. (42) Hong Kong Press Photographers Association. (43) Hong Kong Recreation Management Association Limited. (44) Hong Kong Repertory Theatre Limited. (45) Hong Kong Screen Writers' Guild Limited. (46) Hong Kong Sports Association of the Deaf. (47) Hong Kong Sports Press Association Ltd. (48) Hong Kong Stuntman Association Limited. (49) Hong Kong Tai Chi Association. (50) Hong Kong United Arts Entertainment Company Limited. (51) Min Chiu Society. (52) The New Territories Regional Sports Association. (53) The Newspaper Society of Hong Kong. (54) Pop-Music Authors Society of Hong Kong. (55) The Hong Kong Branch of the Royal Asiatic Society. (56) Sail Training Association of Hong Kong Limited. (57) Society of Cinematographers (Hong Kong) Limited. (58) Society of Film Editors (Hong Kong) Limited. (59) South China Film Industry Workers' Union. (60) South China Research Circle. (61) The Hong Kong Swimming Teachers' Association Limited. (62) Videotage Limited. (63) Zuni Icosahedron. (64) Federation of Hong Kong Filmmakers Limited. (65) Hong Kong Movie Production Executives Association Limited. (66) Hong Kong Sports Institute Limited. (67) The Federation of Motion Film Producers of Hong Kong Limited.

<u>Item</u>	<u>Column 1</u> <u>Constituency</u>	<u>Column 2</u> <u>Electors</u>
23.	Import and export functional constituency	<ul style="list-style-type: none"> (1) Companies licensed under the Dutiable Commodities Ordinance (Cap 109) for the import or export, or import and export, of dutiable commodities. (2) Companies licensed under the Dutiable Commodities Ordinance (Cap 109) immediately before the commencement of the Dutiable Commodities (Amendment) (No. 2) Ordinance 2008 (16 of 2008) for the import, or import and export, of alcoholic liquors. (3) Companies registered under the Motor Vehicles (First Registration Tax) Ordinance (Cap 330) for the import of motor vehicles for use in Hong Kong. (4) Companies licensed under the Control of Chemicals Ordinance (Cap 145) for the import or export, or import and export, of controlled chemicals. (5) Members of each of the following bodies entitled to vote at general meetings of the body– <ul style="list-style-type: none"> (a) The Association of Hong Kong Photographic Equipment Importers Limited; (b) Hong Kong & Kowloon Steel and Metal Importers and Exporters Association Ltd.; (c) The Hong Kong Chinese Importers' & Exporters' Association; (d) The Hong Kong Exporters' Association; (e) Hong Kong Fresh Fruits Importers Association Ltd.; (f) Hong Kong General Association of Edible Oil Importers & Exporters Ltd.; (g) Hongkong Rice Importers & Exporters Association; (h) Hongkong Watch Importers' Association; (i) The Hong Kong Food, Drink & Grocery Association; (j) Hong Kong & Kowloon Light Industrial Products Importers & Exporters Association Limited; (k) Nanyang Importers and Exporters Association; (l) Hong Kong Industrial Production Trading Association Limited; (m) The Industrial Chemical Merchants' Association Limited; (n) Hong Kong Paper Association Limited; (o) The Wah On Exporters & Importers Association; (p) The Hong Kong Shippers' Council; (q) The Shippers' Association of Hong Kong.
24.	Textiles and garment functional constituency	<ul style="list-style-type: none"> (1) Corporate members of the Textile Council of Hong Kong Limited (other than those referred to in para. (2)(a) to (k)) entitled to vote at general meetings of the Council. (2) Corporate members of each of the following bodies entitled to vote at general meetings of the body– <ul style="list-style-type: none"> (a) The Federation of Hong Kong Cotton Weavers;

<u>Item</u>	<u>Column 1</u> <u>Constituency</u>	<u>Column 2</u> <u>Electors</u>
24.	Textiles and garment functional constituency <i>(Cont'd)</i>	<ul style="list-style-type: none"> (b) The Federation of Hong Kong Garment Manufacturers; (c) Hong Kong Chinese Textile Mills Association; (d) The Hong Kong Cotton Made-up Goods Manufacturers Association, Limited; (e) The Hongkong Cotton Spinners Association; (f) Hong Kong Garment Manufacturers Association Ltd.; (g) Hong Kong Knitwear Exporters & Manufacturers Association Ltd.; (h) Hong Kong Woollen & Synthetic Knitting Manufacturers' Association, Ltd.; (i) The Hong Kong Association of Textile Bleachers, Dyers, Printers and Finishers Limited; (j) The Hong Kong Weaving Mills Association; (k) The Hong Kong General Chamber of Textiles Limited. <ul style="list-style-type: none"> (3) Members of the Hong Kong Institution of Textile and Apparel Limited entitled to vote at general meetings of the Institution. (4) Textiles & Clothing manufacturers registered under the Factory Registration of the Trade and Industry Department for the purpose of applying for the certificate of Hong Kong origin. (5) Textiles traders who- <ul style="list-style-type: none"> (a) are registered as textiles traders pursuant to regulation 5A of the Import and Export (General) Regulations (Cap 60 sub. leg. A); (b) have been so registered for a period of 12 months immediately before making the application for registration as an elector; and (c) are carrying on business as textiles traders specified in Schedule 4 to the Import and Export (General) Regulations (Cap 60 sub. leg. A).
25.	Wholesale and retail functional constituency	<p>Members of each of the following bodies entitled to vote at general meetings of the body-</p> <ul style="list-style-type: none"> (1) Anglo-Chinese Vegetable Wholesale Merchants Association Limited; (2) Association of Better Business & Tourism Services; (3) Cheung Sha Wan Poultry United Wholesalers Association Ltd.; (4) Chinese Medicine Merchants Association Ltd.; (5) Chinese Merchants (H.K.) Association Limited; (6) Chinese Paper Merchants Association Limited; (7) The Cosmetic & Perfumery Association of Hong Kong Ltd.;

<u>Item</u>	<u>Column 1</u> <u>Constituency</u>	<u>Column 2</u> <u>Electors</u>
25.	Wholesale and retail functional constituency (<i>Cont'd</i>)	(8) Eastern District Fresh Fish Merchants' Society; (9) Federation of Hong Kong Kowloon New Territories Hawkers Associations; (10) The Federation of Hong Kong Watch Trades and Industries Ltd.; (11) HK Vegetable Wholesaler Community; (12) Hong Kong and Kowloon Bamboo Goods Merchants Association Limited; (13) Hong Kong and Kowloon Electrical Appliances Merchants Association Ltd.; (14) Hong Kong Electro-Plating Merchants Association Limited; (15) Hong Kong & Kowloon European Dress Merchants Association; (16) Hong Kong & Kowloon Fresh Water Fish Merchants' & Buyers' Association Limited; (17) Hong Kong & Kowloon Fruit & Vegetable Employees & Employers Guild; (18) Hong Kong & Kowloon Furniture & Shop Fittings Merchants Association; (19) Hong Kong & Kowloon General Association of Liquor Dealers and Distillers; (20) Hong Kong & Kowloon Machine Made Paper Merchants Association Ltd.; (21) Hong Kong and Kowloon Machinery and Instrument Merchants Association Ltd.; (22) Hong Kong & Kowloon Marine Products Merchants Association Ltd.; (23) Hong Kong & Kowloon Plastic Products Merchants United Association Limited; (24) Hong Kong & Kowloon Poultry Dealers Guild; (25) The Hong Kong & Kowloon Provisions, Wine & Spirit Dealers' Association Limited; (26) Hong Kong and Kowloon Rattan Ware Merchants Association (Wing-Hing-Tong); (27) The Hong Kong and Kowloon Salt Merchants' Association; (28) Hong Kong & Kowloon Sauce & Preserved-Fruit Amalgamated Employers Association; (29) Hong Kong & Kowloon Tea Trade Merchants Association Ltd.; (30) Hong Kong & Kowloon Timber Merchants Association Limited; (31) Hong Kong & Kowloon Vermicelli & Noodle Manufacturing Industry Merchants' General Association; (32) Hong Kong Art Craft Merchants Association, Ltd.; (33) Hong Kong Dried Seafood and Grocery Merchants

<u>Item</u>	<u>Column 1</u> <u>Constituency</u>	<u>Column 2</u> <u>Electors</u>
25.	Wholesale and retail functional constituency (Cont'd)	Association Limited; (34) Hong Kong Dyestuffs Merchants Association Limited; (35) Hong Kong Egg Merchants Association (Fung-Kwai-Tong); (36) Hong Kong Embroidery Merchants Association Limited; (37) Hong Kong Flower Dealers & Workers Association; (38) Hong Kong Flower Retailers Association; (39) The Hong Kong Food Council Limited; (40) Hong Kong Fresh Fish Merchants Association; (41) Hong Kong Fur Federation; (42) Hong Kong Furniture & Decoration Trade Association Limited; (43) Hong Kong General Chamber of Pharmacy Limited; (44) Hong Kong Glass and Mirror Merchants and Manufacturers Association Company Limited; (45) Hong Kong Jewellers' & Goldsmiths' Association Limited; (46) The Federation of Hong Kong Footwear Limited.; (47) The Hong Kong Medicine Dealers' Guild; (48) Hong Kong Metal Merchants Association; (49) The Hong Kong Oil Merchants Association, Limited; (50) Hong Kong Paints & Pigments Merchants Association Ltd.; (51) Hong Kong Petroleum, Chemicals and Pharmaceutical Materials Merchants Association Ltd.; (52) Hong Kong Photo Marketing Association Limited; (53) Hong Kong Piece Goods Merchants' Association; (54) Hong Kong Plastic Material Suppliers Association Ltd.; (55) Hong Kong Plumbing and Sanitary Ware Trade Association Ltd.; (56) Hong Kong Provision & Grocery General Commercial Chamber; (57) Hong Kong Record Merchants Association Ltd.; (58) Hong Kong Rice Suppliers' Association Limited; (59) Hong Kong Retail Management Association Limited; (60) Hong Kong Silk Piece-Goods Merchants' Association; (61) Hong Kong Stamp and Coin Dealers Association; (62) Hong Kong Yee Yee Tong Chinese Medicine Merchants Association Ltd.; (63) The Hong Kong & Kowloon General Merchandise Merchants' Association Limited; (64) Hongkong Kowloon New Territories & Overseas Fish Wholesalers Association Limited; (65) The Industrial Chemical Merchants' Association Limited; (66) Kowloon Cheung Sha Wan Wholesale Vegetable Market (Importers) Recreation Club Limited; (67) Kowloon Fresh Fish Merchants Association Limited; (68) Kowloon Fresh Meat Retailers' Association Ltd.;

<u>Item</u>	<u>Column 1</u> <u>Constituency</u>	<u>Column 2</u> <u>Electors</u>
25.	Wholesale and retail functional constituency (Cont'd)	(69) The Kowloon Pearls, Precious Stones, Jade, Gold & Silver Ornament Merchants Association;
		(70) Kowloon Poultry Laan Merchants Association;
		(71) The Merchants Association of First Wholesalers/Jobbery of Imported Fresh Fruits & Vegetables Limited;
		(72) Mongkok Vegetable Wholesale Merchants Association Company Limited;
		(73) The Motor Traders Association of Hong Kong;
		(74) Nam Pak Hong Association;
		(75) Po Sau Tong Ginseng & Antler Association Hong Kong Ltd.;
		(76) The Rice Merchants' Association of Hong Kong Limited;
		(77) Shaukiwan Fishery Merchants Association;
		(78) Kowloon Fruit & Vegetable Merchants Association Limited;
		(79) The Hong Kong And Kowloon Electric Trade Association;
		(80) Hong Kong Poultry Wholesalers Association;
		(81) Diamond Federation of Hong Kong, China Limited;
		(82) Tobacco Association of Hong Kong Limited;
		(83) Hong Kong Chinese Prepared Medicine Traders Association Limited;
(84) Hong Kong Chinese Medicine Industry Association Limited;		
(85) Hong Kong Chinese Patent Medicine Manufacturers' Association Ltd.		
26.	Information technology functional constituency	(1) Distinguished Fellows, Fellows and Full Members of the Hong Kong Computer Society entitled to vote at general meetings of the Society.
		(2) Fellows, Members and Graduate Members of Information Technology Division of the Hong Kong Institution of Engineers who are entitled to vote at general meetings of the Division.
		(3) Professional Members of the Association for Computing Machinery, Hong Kong Chapter entitled to vote at general meetings of the Association.
		(4) Fellows, Senior Members and Full Members of the Institute of Electrical and Electronics Engineers, Inc., Hong Kong Section, Computer Chapter entitled to vote at general meetings of the Institute.
		(5) Fellows, Senior Members and Full Members of the Institute of Electrical and Electronics Engineers, Inc., Hong Kong Section, Hong Kong Joint Chapter on Circuits and Systems/Communications entitled to vote at general meetings of the Institute.
		(6) Honorary Fellows, Fellows and Members of The Institution of Engineering and Technology Hong Kong

<u>Item</u>	<u>Column 1</u> <u>Constituency</u>	<u>Column 2</u> <u>Electors</u>
26.	Information technology functional constituency <i>(Cont'd)</i>	<p>entitled to vote at general meetings of the Institution who are either –</p> <p>(a) persons registered as Chartered Engineers with the Engineering Council UK; or</p> <p>(b) Corporate Members of The Institution of Electrical Engineers Hong Kong (IEE Hong Kong) before 15 October 2002.</p> <p>(7) Fellows, Members and Associate Members of The British Computer Society (Hong Kong Section) Limited entitled to vote at general meetings of the Society.</p> <p>(8) Fellows, Senior Professional Members and Professional Members of The Hong Kong Association for Computer Education entitled to vote at general meetings of the Association.</p> <p>(9) Full Members (Information Technology) of the Hong Kong Society of Medical Informatics Limited entitled to vote at general meetings of the Society.</p> <p>(10) Full Members of the Information and Software Industry Association Limited entitled to vote at general meetings of the Association.</p> <p>(11) The eligible persons of the following bodies –</p> <p>(a) Hong Kong Software Industry Association Limited;</p> <p>(b) Information Systems Audit and Control Association China Hong Kong Chapter Limited;</p> <p>(c) Internet Professional Association Limited;</p> <p>(d) Professional Information Security Association.</p> <p>(12) Corporate members of each of the following bodies entitled to vote at general meetings of the body–</p> <p>(a) Hong Kong Information Technology Federation Limited;</p> <p>(b) Hong Kong Internet Service Providers Association Limited;</p> <p>(c) Hong Kong Radio Paging Association Ltd.;</p> <p>(d) Communications Association of Hong Kong Limited;</p> <p>(e) Hong Kong Wireless Technology Industry Association Limited;</p> <p>(f) The Society of Hong Kong External Telecommunications Services Providers Limited.</p> <p>(13) Bodies that are holders of one or more of the following classes of licences granted by the Communications Authority under the Telecommunications Ordinance (Cap 106)–</p> <p>(a) Fixed Telecommunications Network Services licences;</p> <p>(b) Services – Based Operator Licence (Class 3</p>

<u>Item</u>	<u>Column 1</u> <u>Constituency</u>	<u>Column 2</u> <u>Electors</u>
26.	Information technology functional constituency (Cont'd)	<p>Service);</p> <p>(c) Public Radiocommunications Service licences;</p> <p>(d) Satellite Master Antenna Television licences;</p> <p>(e) Broadcast Relay Station licences;</p> <p>(f) Broadcast Radio Relay Station licences;</p> <p>(g) Carrier licences.</p> <p>(14) Members of the Hong Kong Information Technology Joint Council Limited entitled to vote at general meetings of the Council.</p> <p>(15) Fellows and Full Members of the Information Security and Forensics Society entitled to vote at general meetings of the Society.</p> <p>(16) APT Satellite Company Limited.</p> <p>(17) Asia Satellite Telecommunications Company Limited.</p>
27.	Catering functional constituency	<p>(1) Holders of food business licences under the Public Health and Municipal Services Ordinance (Cap 132).</p> <p>(2) The Association for the Hong Kong Catering Services Management Limited.</p> <p>(3) The Association of Restaurant Managers Limited.</p> <p>(4) The Hong Kong Restaurant and Eating House Merchants General Association.</p> <p>(5) Hong Kong Catering Industry Association Limited.</p>
28.	District Council (first) functional constituency	Members of the District Councils established under the District Councils Ordinance (Cap 547) who are elected under Part V of that Ordinance.
29.	District Council (second) functional constituency	Persons who are registered electors for GCs but not registered as electors for any of the FCs specified in section 20(1)(a) to (zb) of the LCO.

Note : (1) In item 22 of this Appendix–

- (a) “registered body” (註冊團體) means a body which is registered or exempt from registration under, or incorporated by, any laws of Hong Kong.
- (b) “relevant period” (有關期間), in relation to a statutory body or registered body, means the period from 1 April 1994 to the date on which the statutory body or registered body applies for registration as an elector of the sports, performing arts, culture and publication functional constituency; or if the statutory body or registered body applies for such registration on or after 18 July 2003, the period of 6 years immediately preceding the date on which it so applies.
- (c) “statutory body” (法定團體) means a body established or constituted by or under the authority of an Ordinance.

(2) In item 26(11) of this Appendix, the “eligible persons” means–

- (a) Hong Kong Software Industry Association Limited–Full Members, the major business of which, as confirmed by the Association, has been in the research, development or application of information technology or computer software during the relevant period; and which are entitled to vote at general meetings of the Association;
- (b) Information Systems Audit and Control Association China Hong Kong Chapter Limited – Ordinary Members who are confirmed by the Association to have been holders of the Certified Information Systems Auditor Certification (CISA) during the relevant period; and entitled to vote at general meetings of the Association;
- (c) Internet Professional Association Limited – Members who are confirmed by the Association to have had experience in the information technology field, as specified in the constitution of the Association, during the relevant period; and entitled to vote at general meetings of the Association; and
- (d) Professional Information Security Association – Full Members who are confirmed by the Association to have been holders of the Certified Information Systems Security Professional Certification (CISSP) during the relevant period; and entitled to vote at general meetings of the Association,

where the “relevant period”, in relation to a person, means the period of 4 years immediately preceding the date on which that person applies for registration as an elector of the information technology functional constituency.

[Amended in June 2012 and June 2016]

The Preferential Elimination System of Voting
(applicable to the election of the 4 Special Functional
Constituencies) - How Votes Are Counted
(with Annex showing Working Examples)

1. All valid ballot papers will be sorted with reference to the candidate for whom the first preference vote has been recorded.
2. The result of an election will be ascertained by a count of the first preference votes received by each of the candidates. The candidate who receives an absolute majority (i.e. over 50%) of all the first preference votes received by the candidates will be declared elected (see Example 1 in the Annex). However, where each of the ballot papers contains only a first preference vote without any other valid preference marked on it, the candidate who obtains the highest number of the first preference votes will be elected.
3. Where no candidate has received an absolute majority of all the first preference votes received by the candidates:
 - (a) If each of the candidates has received an equal number of first preference votes, the result of the election will be determined by the drawing of lots (see paras. 3.2 to 3.4 in the Annex).
 - (b) Otherwise, an elimination process accompanied with a transfer of votes will be carried out, i.e. the candidate(s) with the least number of votes will be eliminated and his/her/their votes will be transferred to the other (remaining) candidates according to the next available preference recorded on his/her/their ballot papers (see Example 2 in the Annex).
4. The process in para. 3(b) above will be repeated until:
 - (a) a candidate obtains an absolute majority of the aggregate of the total number of votes (both preference votes and transferred votes) – that candidate will then be declared elected;

- (b) only one candidate is remaining – he/she shall be elected; or

- (c) each of the remaining candidates has received an equal number of votes (i.e. the total number of the first preference votes and the transferred votes), in which case the result of the election will be determined by lot.

The Preferential Elimination System of Voting**WORKING EXAMPLES****Example 1** (where an absolute majority is obtained at the first count)

1.1 At the first count, only first preference votes are counted. The results are as follows :-

First Count	Exhausted Ballot Papers	Valid Ballot Papers	A		B		C		D		E	
			Votes	%	Votes	%	Votes	%	Votes	%	Votes	%
Total Number of Votes	-	100	51	51.00	29	29.00	10	10.00	7	7.00	3	3.00
			Elected									

1.2 Candidate A is elected as he/she has obtained an absolute majority (over 50%) of all the first preference votes.

Example 2 (where an elimination process and a transfer of votes take place)

2.1 In this example, the results of the first count in which only first preference votes are counted are as follows :-

First Count	Exhausted Ballot Papers	Valid Ballot Papers	A		B		C		D		E	
			Votes	%	Votes	%	Votes	%	Votes	%	Votes	%
Total Number of Votes	-	100	3	3.00	2	2.00	44	44.00	44	44.00	7	7.00

2.2 No candidate has obtained an absolute majority of all the first preference votes. Candidate B, who has obtained the least number of first preference votes, is eliminated.

2.3 A second count is then conducted. The 2 ballot papers which show Candidate B as the first preference are transferred to the remaining Candidates (A, C,

D and E) according to the next available (second) preference shown on them. For any ballot papers which express no available preference for any of the remaining candidates or where the next available preference is not clear (e.g. where there is no consecutive preference or where the same preference is marked for 2 or more candidates), they are set aside as "exhausted" and are excluded from any subsequent counting of the total number of valid votes for the purpose of calculating an absolute majority of votes of the winning candidate.

2.4 It is assumed that the next available (second) preferences shown on these 2 ballot papers are as follows :-

<u>Candidates of next available preference</u>	<u>Number of votes</u>
A	0
C	1
D	1
E	0
Nil	0 (exhausted)
	<u>2</u>

2.5 The results of the second count are as follows :-

Second Count	Exhausted Ballot Papers	Valid Ballot Papers	A		C		D		E	
			Votes	%	Votes	%	Votes	%	Votes	%
Own 1st preference votes	-	98	3		44		44		7	
Preference votes transferred from Candidate B	0	2	0		1		1		0	
Total Number of Votes	0	100	3	3.00	45	45.00	45	45.00	7	7.00

2.6 Still no candidate has obtained an absolute majority of all the valid votes in circulation. Candidate A, who has obtained the least total number of votes

at this stage, is eliminated.

2.7 A third count is then conducted. The 3 ballot papers which show Candidate A as the first preference are transferred to the remaining Candidates (C, D and E) according to the next available (second) preference marked on them. If any of these ballot papers shows Candidate B who has already been eliminated at the first count as the 2nd preference, it is transferred to one of the remaining candidates according to the next available (third) preference shown on it. It is assumed that the next available preferences for the remaining candidates shown on the 3 ballot papers under Candidate A are as follows :-

<u>Candidates of next available preference</u>	<u>Number of votes</u>
C	2
D	0
E	0
Nil	<u>1</u> (exhausted)
	3

2.8 The results of the third count are as follows :-

Third Count	Exhausted Ballot Papers	Valid Ballot Papers	C		D		E	
			Votes	%	Votes	%	Votes	%
Own 1st preference votes	-	95	44		44		7	
Preference votes transferred from Candidate B	0	2	1		1		0	
Preference votes transferred from Candidate A	1	2	2		0		0	
Total Number of Votes	1	99	47	47.48	45	45.45	7	7.07

2.9 Still no candidate has obtained an absolute majority of all the valid votes in circulation. Candidate E, who has obtained the least total number of votes at this stage, is eliminated.

2.10 A fourth count is then conducted. The 7 ballot papers which show Candidate E as the first preference are transferred to the remaining Candidates C and D according to the next available (second) preference marked on them. If any of these ballot papers shows Candidate B or Candidate A (both have already been eliminated) as the 2nd preference, it is transferred to one of the remaining candidates according to the next available (third) preference shown on it. If any of these ballot papers shows Candidate A and Candidate B as 2nd and 3rd preferences (or vice versa), it is transferred to the remaining candidates according to the next available (fourth) preferences shown on it. It is assumed that the next available preference shown after Candidate E for the remaining candidates on the 7 ballot papers are as follows :-

<u>Candidates of next available preference</u>	<u>Number of votes</u>
C	4
D	2
Nil	<u>1</u> (exhausted)
	7

2.11 The results of the fourth count are as follows :-

Fourth Count	Exhausted Ballot Papers	Valid Ballot Papers	C		D	
			Votes	%	Votes	%
Own 1st preference votes	-	88	44		44	
Preference votes transferred from Candidate B	0	2	1		1	
Preference votes transferred from Candidate A	1	2	2		0	
Preference votes transferred from Candidate E	1	6	4		2	
Total Number of Votes	2	98	51	52.04	47	47.96

2.12 Candidate C has now obtained an absolute majority of all the valid votes in circulation and is declared elected.

2.13 The following table shows the entire counting process :-

	Exhausted Ballot Papers	Valid Ballot Papers	A		B		C		D		E	
			Votes	%	Votes	%	Votes	%	Votes	%	Votes	%
First Count	-	100	3	3.00	2	2.00	44	44.00	44	44.00	7	7.00
Second Count	0	2	0		Eliminated	1		1		0		
Total Number of votes	0	100	3	3.00		45	45.00	45	45.00	7	7.00	
Third Count	1	2				2		0		0		
Total Number of votes	1	99				47	47.48	45	45.45	7	7.07	
Fourth Count	1	6			4		2					
Total Number of votes	2	98			51	52.04	47	47.96				
							Elected					

The Drawing of Lots

3.1 The result of the election will be determined by the drawing of lots if :-

- (a) in the first count, no candidate has received an absolute majority of all the first preference votes received by the candidates and each of the

candidates has received an equal number of first preference votes; or

- (b) after the elimination process and the transfer of votes have been carried out, no candidate has received an absolute majority of the aggregate of the total number of votes and each of the remaining candidates has received an equal number of votes (i.e. the total number of the first preference votes and the transferred votes).

3.2 10 lots will be used, each being allocated a number ranging from "1" to "10". All lots will be placed in an empty opaque bag.

3.3 The candidates concerned will take turn (in the order in which their names are listed on the ballot paper) to draw a lot, which will be put back into the bag after recording the result and before the next candidate makes his/her draw. The candidate whose lot carries the higher number will emerge as the winner. Number "10" is the highest number.

3.4 This method as to how lots should be drawn allows each candidate to have an equal opportunity to try his/her luck. A candidate may even by chance draw the same lot as his/her opponent. In such an event, a second draw will be conducted. [For detailed arrangement, please make reference to para. 3.36 (a) and (b) of Chapter 3.]

**The Combined Polling Arrangements -
Polling Stations for Various Kinds of Electors
in the General Election**

1. The general election consists of elections of 5 geographical constituencies (“GCs”), the District Council (second) functional constituency (“DC (second) FC”), 24 ordinary functional constituencies (“ordinary FCs”) and 4 special functional constituencies (“SFCs”).
2. Elections of GCs and the DC (second) FC adopt the list system of proportional representation. For the 24 ordinary FCs, the first past the post voting system is applicable to them. Each of the 4 SFCs has a small electorate and the voting system applicable to them is the preferential elimination system.
3. An elector can simply be an elector of the GC, but any elector of the FCs is also an elector of one of the 5 GCs.
4. A person cannot be an elector of more than one of the FCs.
5. All electors of the 5 GCs and DC (second) FC are individuals. However, some of the 24 ordinary FCs and 4 SFCs have corporate electors. A corporate elector can only cast its FC vote by an authorised representative (“AR”) it has appointed. An AR must be a GC elector (see para. 3.13 of Chapter 3). A person who is an AR for one FC cannot be AR for another FC, but he/she can be an elector of another FC. Therefore, a person can be an FC elector and also an AR of another FC.
6. A one-stop service is provided, so that an elector only needs to go to one polling station to cast all the votes which he/she is entitled to cast. Under the combined polling arrangement, each GC elector is allocated to a polling station according to his/her residential address in the final register for GCs, save for registered electors imprisoned or held in custody by the law enforcement agencies who will be assigned to vote at the appropriate dedicated polling stations. Each GC elector will be issued at the polling station or the dedicated polling station the number of ballot papers to which he/she is entitled as the GC elector, elector and/or AR of an FC, as the case may be. There will be no other polling station designated for any of the FCs; and

their electors and ARs will have to cast their votes in polling stations designated for GCs.

7. A cardboard to which a chop with a tick “✓” is attached and a pen for marking the SFC ballot papers, where appropriate, will be provided to each person at the same time as he/she is issued with one or more ballot paper, in order to ensure that he/she must insert the ballot paper(s) issued to him/her in the ballot boxes before he/she leaves the polling station. A **green** cardboard will be issued to a person with 1 GC ballot paper only, a **white** cardboard will be issued to a person with 1 GC ballot paper and 1 DC (second) FC ballot paper, a **red** cardboard to a person with 1 GC ballot paper and 1 FC (other than DC (second) FC) ballot paper and a **blue** cardboard to a person with 1 GC ballot paper and 2 FC ballot papers. The cardboard with the chop and the pen for marking the SFC ballot papers, where appropriate, will have to be handed back by the person to the polling officer manning the ballot boxes after he/she has inserted his/her ballot paper(s) into the ballot box(es) before leaving the polling station.
8. There are going to be 3 kinds of ballot boxes in different colours, in any polling station:
 - (a) ballot box for the GCs;
 - (b) ballot box for the DC (second) FC; and
 - (c) ballot box for the ordinary FCs/SFCs (mixed).
9. The polling arrangements, in their entirety, consist of only 5 scenarios. Each of the scenarios is explained below, and a table containing the 5 scenarios is also provided for easy reference.

THE 5 SCENARIOS**At a local GC polling station or a dedicated polling station :**

1. **A GC elector who has only his/her GC vote** - 1 GC ballot paper for the concerned GC. [The person shall insert his/her GC ballot paper into the GC ballot box.]
2. **A DC (second) FC elector** - 1 GC ballot paper for the concerned GC + 1 DC (second) FC ballot paper. [The person shall insert his/her GC ballot paper into the GC ballot box and his/her DC (second) FC ballot paper into the DC (second) FC ballot box.]
3. **A DC (second) FC elector who is also an AR of an ordinary FC/SFC** - 1 GC ballot paper for the concerned GC + 1 DC (second) FC ballot paper + 1 ordinary FC/SFC ballot paper. [The person shall insert his/her GC ballot paper into the GC ballot box, his/her DC (second) FC ballot paper into the DC (second) FC ballot box and his/her another FC ballot paper into the ordinary FC/SFC ballot box.]
4. **An ordinary FC/SFC elector/AR** - 1 GC ballot paper for the concerned GC + 1 ordinary FC/SFC ballot paper. [The person shall insert his/her GC ballot paper into the GC ballot box and his/her ordinary FC/SFC ballot paper into the ordinary FC/SFC ballot box.]
5. **An ordinary FC/SFC elector who is also an AR of another ordinary FC/SFC** - 1 GC ballot paper for the concerned GC + 1 ordinary FC/SFC ballot paper + 1 ordinary FC/SFC ballot paper as an AR. [The person shall insert his/her GC ballot paper into the GC ballot box, and both his/her ordinary FC/SFC ballot papers into the ordinary FC/SFC ballot box.]

The 5 Scenarios of Polling Arrangements

Type of Elector/AR			No. of Ballot Papers Issued	Cardboard Issued
GC	DC (second) FC	Ordinary FC / SFC		
Yes			1	Green
Yes	Elector		2	White
Yes		Elector or AR	2	Red
Yes	Elector	AR	3	Blue
Yes		Elector and AR	3	Blue

[Amended in January 2010, June 2012 and June 2016]

**Submission Method, Formats and Standard on Posting
Electronic Copy of Election Advertisement and Relevant
Information/Documents onto an Open Platform for Public Inspection
(with Annexes I and II on the guidelines and basic layout
design requirements for Candidate's Platform)**

1. To comply with the public inspection requirement governing election advertisements (“EAs”) under the electronic submission method as stipulated in s 105(2) of EAC (EP) (LC) Reg, a candidate must post the following EA particulars as applicable, **within one working day**¹⁷ after the publication of an EA, onto an **open platform** either maintained by the Chief Electoral Officer (“CEO”) (“Central Platform”) or himself/herself/a person authorised by him/her (“Candidate’s Platform”) for public inspection:

- (a) an electronic copy of an EA;
- (b) a hyperlink of the open platform¹⁸ which publishes an EA (where it is technically impracticable to make available an electronic copy of the EA [such as when messages are sent through social networking or communication websites on the Internet like Twitter, Facebook, blogs, etc. and the exchanges are of an interactive and spontaneous nature]);
- (c) the relevant printing/publication information pertaining to such EA including:
 - the name and address of the producer/printer;
 - the date of production/printing;
 - the size/dimension;
 - the manner of publication;
 - the date of publication;
 - the number of copies published; and
 - the number of copies produced/printedas applicable;
- (d) an electronic copy each of the relevant permission/authorisation for the publication of such EA, as applicable (except those provided by the Returning Officer in connection with the

¹⁷ A “working day” means any day other than a general holiday or Saturday.

¹⁸ Open platform means a platform operated through the Internet to which the public has access without having to go through an access control process put in place for that platform.

allocation of designated spots); and

- (e) an electronic copy each of the documents providing consent of support.

Central Platform

2. If a candidate chooses to post the EA particulars onto the Central Platform, he/she must comply with the requirements set out in the ensuing paragraphs.

Submission Method

3. A candidate/list of candidates is required to apply to the CEO in a specified form for creation of an account to access the Central Platform before he/she/they can post EA particulars onto the platform for public inspection. Only one account will be created for each candidate/list of candidates. For a list of candidates, any candidate on the list can apply on behalf of the list for creation of an account but all candidates on the list can access the platform by using the registered username and password.

4. The CEO will inform the candidate/list of candidates concerned upon creation of the account and will provide a username and password (which can subsequently be changed by the relevant candidate) to the candidate/list of candidates concerned **within 3 working days** upon receiving an application. The candidate/list of candidates then can access the platform by using the registered username and password.

5. Uploading of EA particulars onto the platform at any one time by a candidate/list of candidates will be treated and referred to as one single submission. Subject to the file size limit stipulated in para. 7 below, there is no limit on the number of EA or other documents to be included in a submission. If subsequent correction to any EA particulars in a submission is required, the candidate/list of candidates is required to post the corrected EA particulars, including the corrected printing/publication information (“corrected information”) of the EA, onto the platform by selecting the EA particulars concerned. If accepted, both the original and the corrected EA particulars would be displayed alongside for public inspection. Any such corrective information should be posted onto the platform **not later than 2 working days after the polling day**.

6. An acknowledgement of receipt in the form of a summary report of the EA particulars successfully uploaded would be automatically generated

for reference by the candidate after each submission. In addition, an e-mail and a Short Message Service (“SMS”) to acknowledge receipt of the EA particulars successfully uploaded would also be sent to the e-mail address and mobile phone number provided on the application form for creating an account.

File Size

7. The size of each file **must not exceed 50 MB**. Otherwise, the submission will be rejected.
8. Files included in a submission may be compressed using a file format of either Zip (.zip) or GNU zip (.gz).
9. A file exceeding the above size limit will not be accepted. In such circumstances, the candidate may upload the EA particulars in separate files.

Format

10. Files included in a submission must be given, served or presented in the following file formats –

General Document

- (a) Rich Text Format (RTF) or Microsoft Word Format (DOC/DOCX);
- (b) Hypertext Mark Up Language (HTML) Format;
- (c) Adobe Portable Document Format (PDF);
- (d) Plain Text (TXT)

Graphics/Images

- (e) Graphics Interchange Format (GIF);
- (f) Joint Photographic Experts Group (JPEG);
- (g) Tag Image File Format (TIFF);
- (h) Portable Network Graphics (PNG)

Audio

- (i) Waveform Audio Format (WAV);
- (j) MPEG-1 Audio Layer 3 (MP3);

Video

- (k) Audio Video Interleave (AVI);
- (l) Moving Picture Experts Group (MPEG).

Candidates are encouraged to make arrangement such that the files, including text and video, etc., uploaded onto the Central Platform should be accessible to persons with disabilities as far as possible.

Computer Instructions

11. The files uploaded must not contain any computer viruses or any computer instructions including, but not limited to, macros, scripts and fields which depend on the execution environment and the execution of which will cause changes to the files themselves or the information system displaying the files.

Candidate's Platform

12. If a candidate/list of candidates chooses to maintain a platform of his/her/their own for the posting of EA particulars for public inspection, he/she/they must provide the electronic address of the platform to the CEO **at least 3 working days before publication of the first EA**. To avoid causing confusion to members of the public, the platform should be dedicated to the sole purpose of posting EA particulars for public inspection. Candidates of different geographical/functional constituencies are also allowed to use a common platform but candidates concerned are advised to ensure that their EA particulars should be presented in a way that will not cause confusion to the public during the inspection process. The EA particulars posted on the platform should be virus-free and should be organised in a descending order of the date of submission. The required printing/publication information should also be posted alongside the relevant EAs to which the information relates. To maintain consistency in design and, also, to facilitate public inspection, the CEO will provide guidelines and specify the basic layout design requirements for such platform for candidates to follow (see **Annex (I) and Annex (II)**). The guidelines and basic layout design requirements can also be downloaded from the EAC website.

13. If the candidate wishes to correct any EA particulars already posted onto the platform, he/she should post the corrected EA particulars, together with date of correction alongside with the original EA particulars for public inspection (see **Annex (II)**). Any such corrected information should be posted onto the platform **not later than 2 working days after the polling day**.

14. The candidate should not remove any EA particulars already uploaded onto the platform at will except in circumstances where such removal has been directed by the CEO, EAC or the Court, as applicable, in respect of any content/information which is unlawful or not related to any EAs published by the candidate. In the event that an EA has to be removed as directed by the CEO, EAC or the Court, the candidate should post a note to inform the public about the removal of the EA and the reason for such removal. Other documents/information related to the removed EA should still be displayed at the platform for public inspection (see **Annex (II)**).

15. When posting EA particulars onto the Candidate's Platform, candidates should also follow the requirements regarding file format and computer instructions as detailed in paras. 10 to 11 above.

16. The CEO will arrange to publicise the electronic address of the platform to facilitate public inspection of the EA particulars.

Important Points to Note

17. EA particulars must conform to the requirements as set out above. For any electronic files containing images, they should be of sufficient resolution to ensure that the content is both legible and readable to readers.

18. A candidate/list of candidates is solely responsible for (and that the CEO has no responsibility to him/her/them or any third party for) the content/information of the EA particulars uploaded and posted onto the Central Platform, including any hyperlinks to external websites. The CEO reserves the right to remove any of the EA particulars posted on the Central Platform containing such content/information which is unlawful, not related to any EAs published by the candidate/list of candidates or which has been contaminated with computer virus after the submission. In case if the removal is due to computer virus contamination, the candidate/list of candidates will be informed to upload the relevant EA particulars onto the Central Platform again.

19. Candidates should observe all prevailing legal requirements on personal data privacy when uploading information onto the aforesaid platforms for public inspection. In particular, for the documents containing/conveying the required permission/authorisation and/or consent of support pertaining to an EA, candidates are reminded to obliterate the identity document number(s), if any therein, of the person(s) providing such permission/authorisation and/or consent of support before uploading them onto the platforms.

[Added in June 2012 and amended in June 2016]

Points to Note for Building Candidate's Platform**General**

- The name of the election should be shown on the candidate's platform, e.g. 20XX Legislative Council General Election/By-election.
- The name of the geographical/functional constituency should be shown on the candidate's platform, e.g. 'Geographical Constituency – Hong Kong Island' or 'Functional Constituency – Accountancy'.
- The name(s) of the candidate(s) concerned should be shown on the candidate's platform. For a list of candidates, all the names should be shown.
- The candidate number or alphabet/candidate list number should be shown on the candidate's platform once available.
- The EA particulars (including electronic copy of the EA, hyperlink, consent, permission or authorisation documents, etc.) should be displayed and arranged in descending order according to the date of publication.
- The required information to be shown for each EA can be found in **Annex II**.
- The corrected EA particulars should be posted alongside or beneath the original version.
- The candidate should not remove any EA particulars already uploaded onto the candidate's platform at will except in circumstances where such removal has been directed by the Chief Electoral Officer ("CEO"), Electoral Affairs Commission ("EAC") or the Court, as applicable, in respect of any content/information which is unlawful or not related to any EAs published by the candidate. In the event that an EA has to be removed as directed by the CEO, EAC or the Court, the candidate should post a note onto the platform to indicate any removed EA and the reason for such removal. Other documents/information related to the removed EA should still be displayed at the platform for public inspection.
- The file format and computer instruction should follow the details shown at **Appendix E** of the Guidelines on Election-related Activities in respect of the Legislative Council Election.
- Sensitive personal data should not be posted onto the candidate's platform. For example, any Hong Kong Identity Card Number shown on the consent form should be covered before uploading onto the candidate's platform.

- An e-mail contact and/or telephone number should preferably be provided on the Platform for handling public enquiry and providing technical assistance as required.

Security

- To guard against intruder attacks, the candidate's platform should be protected by firewall and/or Intrusion Protection System.
- All files posted in the candidate's platform should be properly scanned by anti-virus software before posting.
- To protect against data loss, please conduct regular backup.
- The hyper-links to external websites should also be checked regularly in order to ensure that they are up-to-date.
- For more information and resources on the information security on the web, please refer to www.infosec.gov.hk.

Accessibility

- The candidate's platform should be accessible by browsers and operating systems commonly used in personal computers.
- For any electronic files containing images, they should be of sufficient resolution to ensure that the content is both legible and readable to readers.
- The platform should be available in English and Chinese and the text content thereon should be readable and understandable. Furthermore, suitable instructions should be provided to assist readers to navigate through the platform.
- The candidate's platform should be accessible to persons with disabilities as far as possible.

[Added in June 2012 and amended in June 2016]

候選人平台建議版面設計 Proposed Layout Design of Candidate's Platform

選舉 Election: 20XX 立法會換屆選舉/補選 20XX Legislative Council General Election/By-election

地方選區 Geographical Constituency: 香港島 HONG KONG ISLAND

候選人名單號碼 Candidate List No.: 1

候選人姓名 Candidate(s) Name(s): (a) 陳大文 Chan Tai Man (b) 李小明 Lee Siu Ming

選舉廣告詳情 (依發布日期降序排列) Election Advertisement Particulars (in descending order according to 'Date of Publication')

項目 Item	選舉廣告類別 Election Advertisement Type	製作/ 印刷日期 Date of Production/ Printing (dd-mm-yyyy)	製作/ 印刷的文 本數目 Number of Copies Produced/ Printed	發布日期 Date of Publication (dd-mm-yyyy)	發布的文本 數目 Number of Copies Published	選舉廣告 檔案/連結 Election Advertisement File/Link	准許/授權 Permission/ Authorisation	尺寸/ 面積 Size/ Dimension	發布方式 Manner of Publication	製作人/印刷 人的姓名 Name of Producer/ Printer	製作人/ 印刷人的 地址 Address of Producer/ Printer	修正日期 Date of Correction (dd-mm-yyyy)	選舉廣告 檔案/連結 移除日期 Date of Removal of Election Advertisement File/Link (dd-mm-yyyy) [Reason 原因]
1	小冊子 Pamphlets	12-08-2016	100	14-08-2016	100	File1.jpg	-	A4	街頭派發 Distributed on street	AA 印刷 公司 AA Printing Company	地址 Address	-	-
2	橫額 Banners	11-08-2016	20	13-08-2016	20	File2.jpg	Authorisation. jpg	1 米 x 2.5 米 1m x 2.5m	懸掛於 路邊鐵欄 Hung on roadside railing	BB 製作 公司 BB Producer	地址 Address	-	-
註 Note	-	-	-	-	-	File2 (Revised).jpg	-	-	-	-	-	14-08-2016	-
3	海報 Posters	10-08-2016	150	12-08-2016	150	http://www.XXX.com.hk/poster.jpg	Permission.jp g	A3	大廈大堂 張貼 Posted at lobby of a building	CC 印刷 公司 CC Printing Company	地址 Address	-	-

註：只顯示曾被修正的資料。 Note: Only corrected particular(s) will be shown.

同意書 Consent

項目 Item	檔案 File	備註 Remark
1	Consent1.jpg	
2	Consent2.jpg	同意書已於 17-08-2016 撤銷 Consent revoked on 17-08-2016

[Added in June 2012 and amended in June 2016]

Methods of Folding of Election Mail 郵寄選舉郵件應採用的摺疊方法⁽¹⁾

Figure 1 : Folder of A4 (296mm) size
圖示一：對摺的A4（296毫米）尺寸紙張

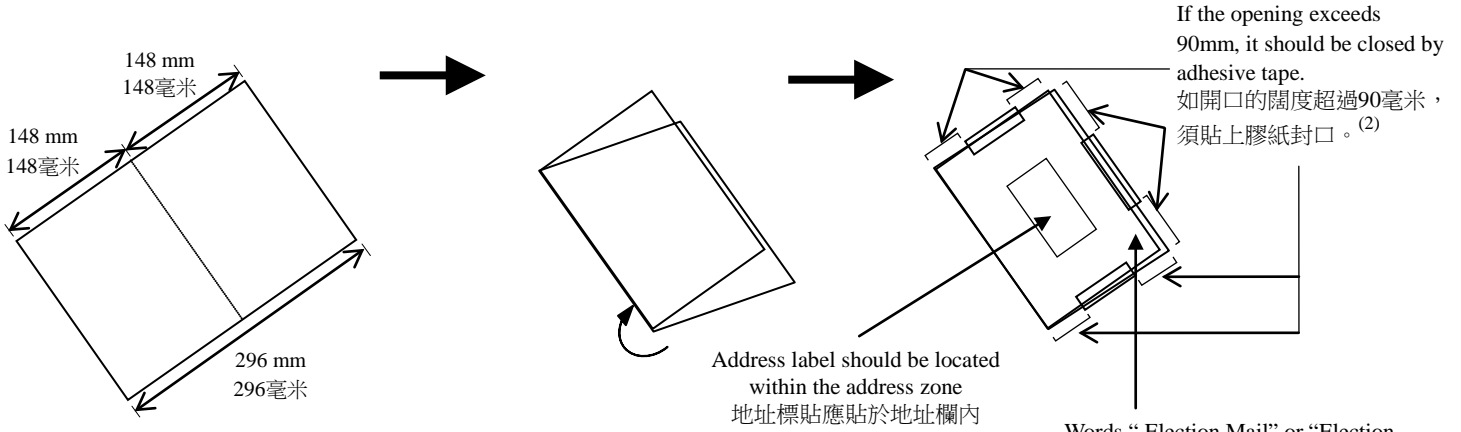

Figure 2 : Folder of A4 (296mm) size with 2 folds
圖示二：兩摺的A4（296毫米）尺寸紙張

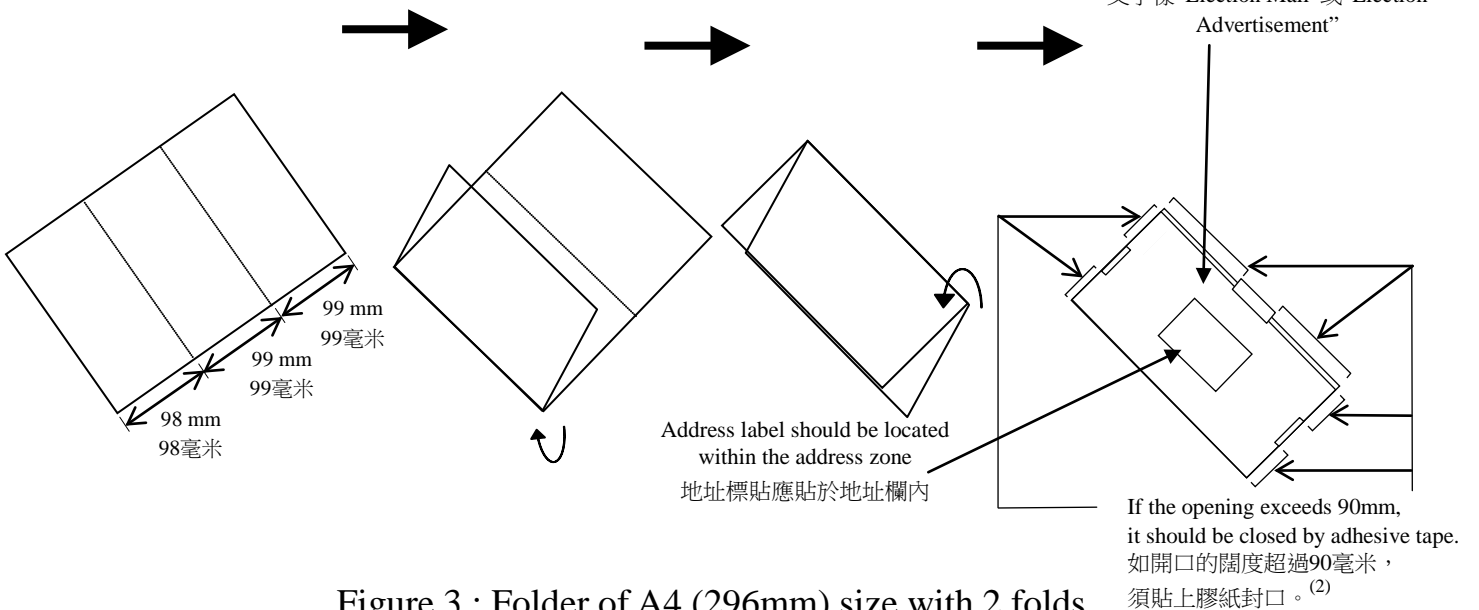
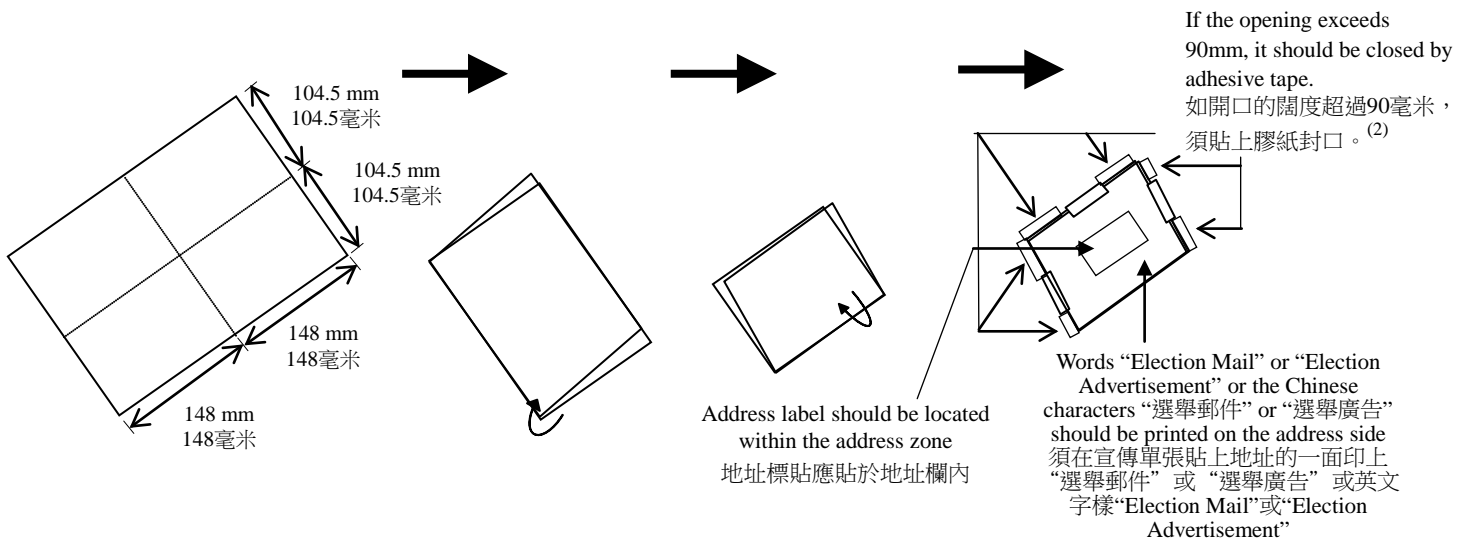

Figure 3 : Folder of A4 (296mm) size with 2 folds
圖示三：兩摺的A4（296毫米）尺寸紙張



Methods of Folding of Election Mail 郵寄選舉郵件應採用的摺疊方法⁽¹⁾

Figure 4A&4B : Folder of A4 (296mm) size sealed with address label
圖示四A及四B：以地址標貼封口的A4（296毫米）尺寸紙張

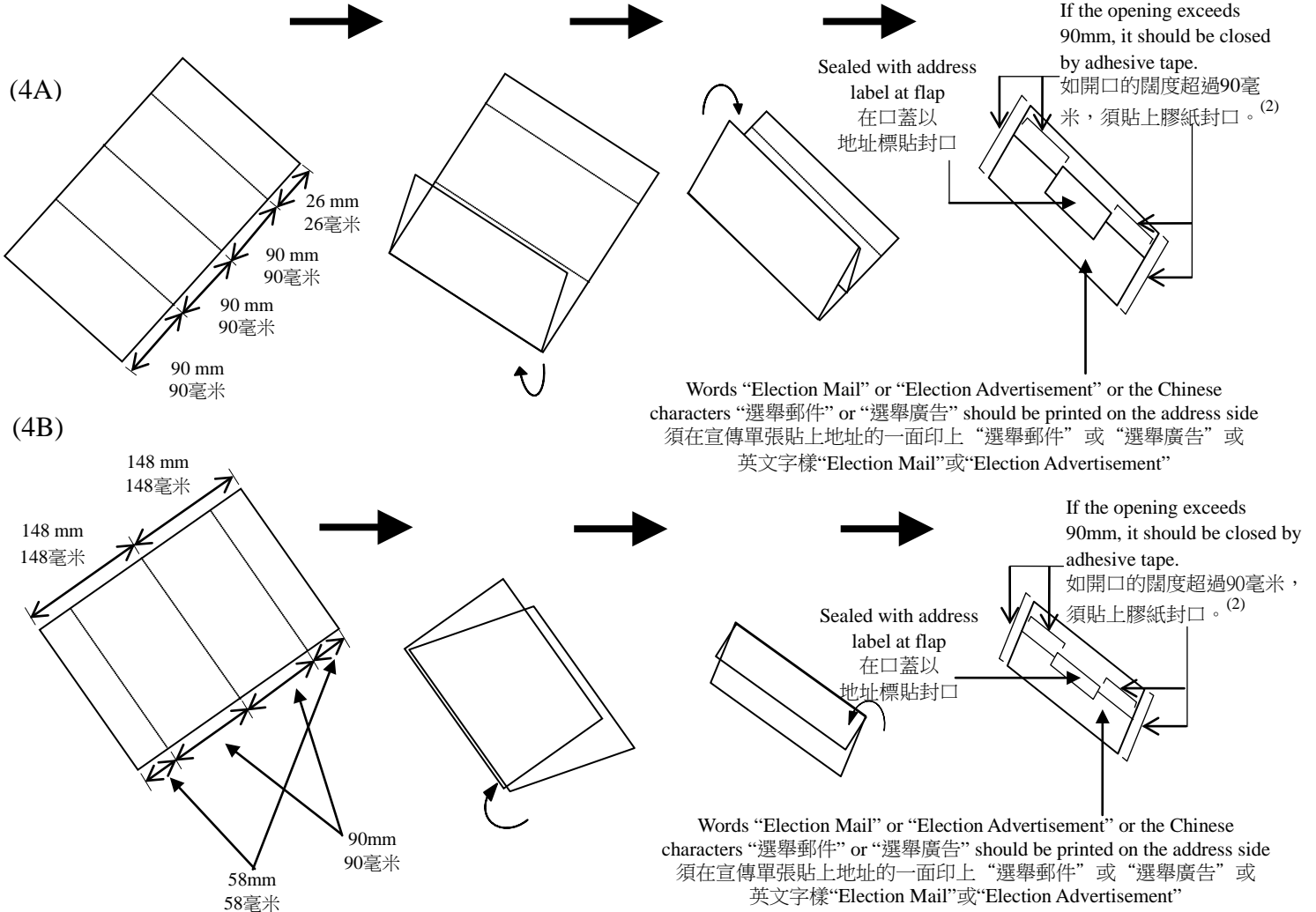
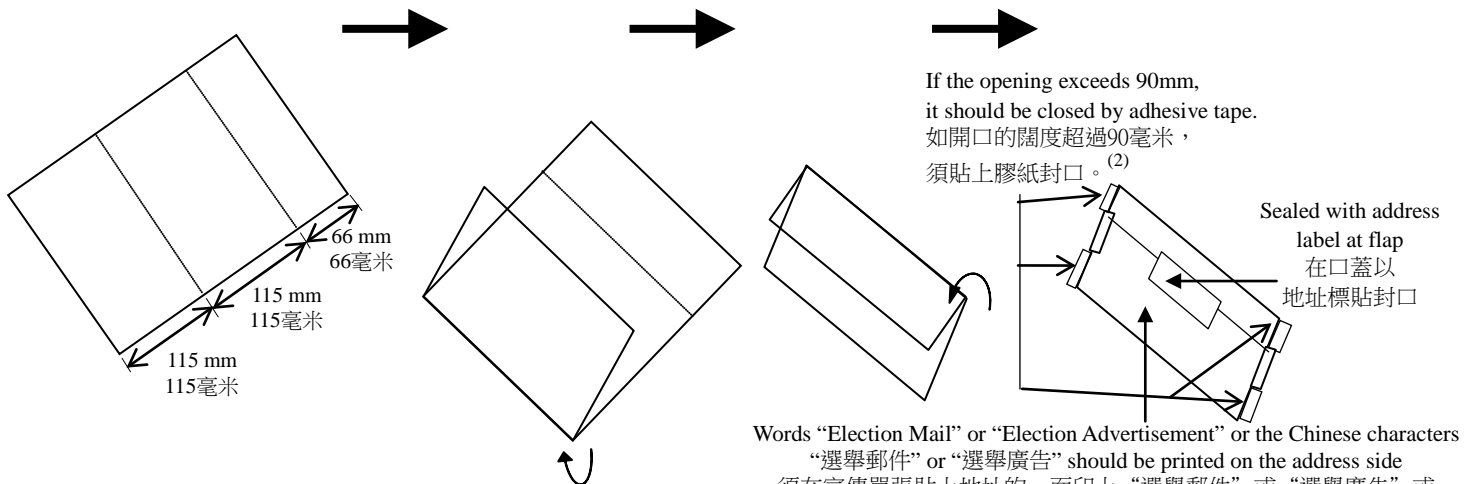

Figure 5 : Folder of A4 (296mm) size sealed with address label
圖示五：以地址標貼封口的A4（296毫米）尺寸紙張



- (1) 無論以任何方法摺疊，所有超過90毫米的開口，必須以膠紙封口。
For any methods of folding, all openings exceeding 90 mm should be closed by adhesive tape.
- (2) 無論郵件的開口是否已經封口，所有開口部分不得超過90毫米，否則須以膠紙封口。
Regardless of whether the opening is closed or not, all openings shall not exceed 90 mm. Otherwise, they must be sealed with adhesive tape.

Canvassing Activities which are Forbidden
Within a No Canvassing Zone

- (Note: (1) This list is by no means an exhaustive list of the canvassing activities which are prohibited within a no canvassing zone. It only serves to illustrate some of the common forms of canvassing activities.
- (2) Door-to-door canvassing and for the purpose of such canvassing, the display or wearing of propaganda material, e.g. any badge, emblem, clothing or head-dress which may promote or prejudice the election of a candidate or candidates at the election, or makes direct reference to a body any member of which is standing as a candidate in the election or to a prescribed body the registered name or registered emblem of which has been printed on ballot paper for the election, will be allowed on storeys above or below street level in a building within a no canvassing zone other than a building in which there is a polling station provided that permission has been obtained for entry to the building for canvassing votes, and that obstruction is not posed to electors and no sound amplifying system or device is used (except for the performance of duties by officers of the CSD on the polling day at dedicated polling stations situated in prisons.) *[Amended in June 2012]*
1. Unauthorised static display of election advertisements on walls (including the outer walls of the polling station), windows, railings, fences, etc.
 2. Exhibition of portable displays on vehicles (whether in motion or parked within the area), or held or carried by persons.
 3. Except for the purpose of door-to-door canvassing referred to in Note (2) above, displaying or wearing any propaganda material, e.g. any badge, emblem, clothing or head-dress which:
 - (a) may promote or prejudice the election of a candidate or candidates at the election; or
 - (b) makes direct reference to a body any member of which is standing as a candidate in the election or a prescribed body

the registered name or registered emblem of which has been printed on ballot paper for the election.

4. Distribution of election advertisements.
5. Canvassing for votes by:
 - (a) talking to electors;
 - (b) shouting slogans or the name or number of a candidate or any appeal message;
 - (c) singing or chanting; or
 - (d) making signals or signs to electors.
6. Broadcast of audio or video recording to appeal to or induce electors to vote.
7. Using loud-hailers or loudspeakers (whether carried by a person or mounted on a vehicle or installed in any other manner) to broadcast any message which appeals to or induce electors to vote.
8. Shaking hands with electors.

[Amended in October 2007, June 2012 and June 2016]

**Conduct of Electioneering Activities and Election Meetings in
Premises under the Management of the Housing Department and
the Hong Kong Housing Society**

Candidates must obtain **prior approval** from the Housing Manager before conducting any electioneering activities or election meetings inside a housing estate, in addition to compliance with regulations and conditions imposed by other relevant authorities. An **application** for approval **should be made at least 2 clear working days (excluding Saturday, Sunday or public holiday) before the date of the meeting**, and the applicant will be notified as soon as practicable after a decision is arrived at. To avoid conflict that may arise from allowing 2 or more candidates and their supporters to hold election meetings in a housing estate at the same venue and time, the Housing Department and the Hong Kong Housing Society will process the applications as soon as practicable and will adopt the following arrangements:

- (a) if only 1 application for holding an election meeting at a particular venue and at a particular time is received, that application will be approved;
- (b) if 2 or more applications for the same venue and the same period are received by the Housing Department or the Hong Kong Housing Society 2 clear working days before the activity takes place, the applicants will be advised to negotiate among themselves to reach a compromise on condition that no canvassing from 2 or more groups will be held at the same place and at the same time to avoid any dispute or clash. If no compromise can be reached, allocation of venue or time will be made by the drawing of lots at a time to be decided by the relevant estate Housing Manager;
- (c) for the purpose of (a) and (b) above, an application for several periods will be dealt with as separate applications for each of the periods; and
- (d) the Housing Manager should send a copy of the letter of approval to the respective Returning Officer for record and for public inspection.

[Added in October 2007]



Guidance Note

Guidance on Electioneering Activities

Introduction

This guidance note serves as a general reference on compliance with the requirements under the Personal Data (Privacy) Ordinance (the “**Ordinance**”) in relation to electioneering activities that may involve the collection and use of personal data of individuals. Very often, candidates and/or their election agents make electioneering approaches by telephone to prospective voters/voters. Candidates may also choose to lobby potential voters by other approaches such as fax messages, SMS/MMS or emails. In some cases, the relevant individuals have no previous dealings with the caller and/or the candidate; and they are concerned that the candidate might have obtained their personal data from sources other than the register of electors.

Relevant Data Protection Principles

The act of canvassing for votes is not in contravention of the Ordinance provided that handling of personal data is in compliance with the data protection principles in Schedule 1 to the Ordinance. Of particular relevance are the requirements under data protection principles 1, 2, 3 and 4 (“**DPP1**”, “**DPP2**”, “**DPP3**” and “**DPP4**”) set out in Schedule 1 to the Ordinance:

DPP1(1) requires that personal data shall not be collected unless the data is collected for a lawful purpose directly related to a function or activity of the data user; and the data collected is necessary, adequate but not excessive in relation to that purpose;

DPP1(2) requires that personal data shall be collected by means that are lawful and fair in the circumstances of the case;

DPP1(3) requires that on or before collecting personal data directly from a data subject, the data user shall take all reasonably practicable steps to ensure that the data subject has been informed of whether it is obligatory or voluntary for him to supply the data and the consequences for him if he fails to supply the data. The data subject shall be explicitly informed of the purpose of data collection and the classes of transferees to whom the data may be transferred as well as the name/job title and address of the individual to whom the request of access to and correction of the data subject’s personal data may be made;

DPP2(2) requires that all practicable steps must be taken to ensure that personal data is not kept longer than is necessary for the fulfillment of the purpose (including any directly related purpose) for which the data is or is to be used;

DPP2(3) requires that if a data user engages a data processor¹ (whether within or outside Hong Kong) to process personal data on its behalf, the data user must adopt contractual or other means to prevent any personal data transferred to the data processor from being kept longer than is necessary for processing of the data;

DPP3 provides that personal data shall not, without the prescribed consent of the data subject, be used for a new purpose, i.e. any purpose other than the purpose for which the data was to be used at the time of the collection of the data or a directly related purpose;

¹ “Data processor” means a person who processes personal data on behalf of another person and does not process the data for any of the person’s own purposes.

DPP4(1) requires that all reasonably practicable steps shall be taken to ensure that personal data is protected against unauthorised or accidental access, processing, erasure, loss, or use; and

DPP4(2) requires that if a data user engages a data processor (whether within or outside Hong Kong) to process personal data on the data user's behalf, the data user must adopt contractual or other means to prevent unauthorised or accidental access, processing, erasure, loss or use of the data transferred to the data processor for processing.

Guidance for Candidates

1. Candidates who seek to collect and use personal data in electioneering should be mindful of the provisions in DPP1, DPP2, DPP3 and DPP4.
2. Candidates should assume direct responsibility for briefing and supervising members of their campaign staff to ensure their compliance with the requirements of the DPPs.
3. When collecting personal data directly from an individual or indirectly from a third party (e.g. a trade union or professional body) for the purpose of electioneering, only adequate but not excessive personal data necessary for an electioneering purpose shall be collected (e.g. Hong Kong Identity Card number should not be collected).
4. Candidates who solicit personal data directly from an individual for electioneering should ensure that the individual is informed of the purpose of collection of the data.
5. Candidates should not collect personal data for electioneering by deceptive means or by mis-representing the purpose of the collection (e.g. collecting personal data in the pretext of opinion poll or assisting citizens to apply for government welfare).
6. With respect to the use of personal data gathered from the published register of electors, due care should be taken to ensure that it is used only for purposes relating to an election as prescribed by the relevant election legislations.
7. Should candidates want to use personal data from sources other than the register of electors for an electioneering purpose, express consent from the data subject must be obtained beforehand, unless the original purpose of collection of the data is directly related to the electioneering purpose.
8. With respect to the use of personal data gathered by a third party (e.g. a trade union or professional body) as a means of accessing members of those bodies for an electioneering purpose, the proper course of action would be for these bodies to determine whether this is a permitted purpose for which the personal data was collected, and such electioneering communication should preferably be handled by these bodies. As a matter of good practice, prior notification to members of such use of their data is recommended.
9. When candidates or their election agents contact individual voters for an electioneering purpose, they should inform the voters how they obtained the voters' personal data when being asked.
10. As a matter of good practice, when canvassing for votes from individuals directly by the candidates, their agents or indirectly through a third party (e.g. trade union or professional body), the individuals should be provided with an option to decline receipt of any subsequent electioneering communication in relation to the election from the candidates concerned so that they would not receive any unwanted electioneering communication from those candidates.

11. As a matter of good practice, candidates should maintain a list of individuals who, to their knowledge, find electioneering communication such as phone calls, mails, fax messages, emails or visits objectionable and avoid approaching them to canvass for votes.
12. When conducting electioneering activities, candidates and their election agents should safeguard the personal data in the list of voters held by them against accidental or unauthorised access by unrelated parties.
13. Candidates should not retain any personal data collected for an electioneering purpose after completion of all the electioneering activities.
14. When election agents are appointed or engaged by the candidates to process the personal data of voters on their behalf for electioneering purpose, the candidates must use contractual or other means to prevent the personal data transferred to the election agents from: (i) being kept longer than is necessary for the electioneering purpose; and (ii) unauthorised or accidental access, processing, erasure, loss or use. Reference can be made to the Information Leaflet on *Outsourcing the Processing of Personal Data to Data Processors*² issued by the Office of the Privacy Commissioner for Personal Data, Hong Kong.

**Office of the Privacy Commissioner for Personal Data,
Hong Kong**

Enquiry Hotline: (852) 2877 7026
 Fax: (852) 2827 2827
 Address: 12/F, Sunlight Tower,
 248 Queen's Road East, Wanchai,
 Hong Kong
 Website: www.pcpd.org.hk
 Email: enquiry@pcpd.org.hk

Copyrights

Reproduction of all or any parts of this guidance note is permitted on condition that it is for non-profit making purposes and an acknowledgement of this work is duly made in the reproduction.

Disclaimer

The information provided in this guidance note is for general reference only. It does not provide an exhaustive guide to the application of the Personal Data (Privacy) Ordinance (the "Ordinance"). For a complete and definitive statement of the law, direct reference should be made to the Ordinance itself. The Privacy Commissioner for Personal Data (the "Commissioner") makes no express or implied warranties of accuracy or fitness for a particular purpose or use with respect to the above information. The above suggestions will not affect the functions and power conferred to the Commissioner under the Ordinance.

© Office of the Privacy Commissioner for Personal Data, Hong Kong
 First published in June 2000
 April 2004 (First Revision)
 February 2007 (Second Revision)
 April 2010 (Third Revision)
 October 2011 (Fourth Revision)
 August 2015 (Fifth Revision)

² Available at www.pcpd.org.hk/english/resources_centre/publications/information_leaflet/files/dataprocessors_e.pdf

**Complaint Cases Provided by
Office of the Privacy Commissioner for Personal Data (“OPCPD”)**

In order to facilitate better understanding of the privacy concerns of the electors and compliance with the requirements of the Personal Data (Privacy) Ordinance (Cap 486), the OPCPD has provided the following 4 complaint cases for illustration purpose:

Case 1

This complaint relates to the collection and use of personal data. A complainant provided his name and telephone number to an incumbent member seeking his assistance in relation to disability allowance. Subsequently, the member used the complainant’s personal data without his consent for election publicity purposes. The member claimed that at the time when the complainant’s personal data was collected, the complainant had been verbally informed that his personal data would be used for communication purposes.

In response to the complaint, the member agreed to provide a written personal information collection statement to individuals stating explicitly that the personal data collected would be used for electioneering purpose.

Case 2

The complaint relates to the use of personal data. A complainant sought assistance from a political party in relation to the management of the building in which he resides and for this purpose supplied his personal data. Subsequently, the political party used the complainant’s personal data in canvassing him to vote for a candidate in an election.

The OPCPD relayed the complainant’s concern to the political party. The party should obtain an express and voluntary consent from the complainant before using his personal data for electioneering purpose.

Case 3

The complaint relates to the security of personal data. An incumbent member sent an email to a list of recipients canvassing vote for a candidate in an election without hiding the names and email addresses of the recipients (by, for example, use of “bcc”). The complainant, being one of the recipients of that email, complained that his name and email address were disclosed to all other recipients of that email.

The OPCPD relayed the complainant’s concern to the member, with the advice that he should safeguard the security of the personal data of the electors when transmitting messages via electronic means.

Case 4

The complaint relates to the use of personal data. A complainant enrolled in a course organised by a political party. After the completion of the course, the complainant was asked to fill in a questionnaire and provided her personal data for “communication purpose”. Subsequently, the political party used the complainant’s personal data in canvassing her to vote for a candidate in an election.

The OPCPD relayed the complainant’s concern to the political party. In response, the party revised the personal information collection statement in the questionnaire by stating explicitly that personal data collected would be used for “electioneering purpose” and deleted the complainant’s personal data. The OPCPD accepted the remedial actions taken but warned the political party that enforcement notice may be issued if similar circumstances occur again.

[Added in June 2012 and amended in June 2016]

Guidance Note on Safe Conduct of Election-related Activities

Introduction

1. This guidance note serves to provide general advice to candidates and organisers of election related activities, to enable them to conduct such activities safely.

Election Meetings

2. The Public Order Ordinance (Cap 245) and Chapter 10 Part II of the 'Guidelines on Election-related Activities in respect of the Legislative Council Election' provide direction on when a meeting, to be held in a public place, is to be notified to the Police and the procedures to be followed.

3. In the interests of safety, and to minimise the potential for confrontation and/or the harassment of candidates, irrespective of whether an election meeting is required to be notified to the Police, candidates should be mindful of the sensitivities of their intended audience. In this regard, consideration should be given to making appropriate arrangements with the local management office, if one exists, to facilitate the holding of the meeting. Should a candidate have any concerns over the issue on his/her safety, consideration should be given to seeking advice from the local police station, prior to the holding of such meeting.

Election Forums

4. In addition to the provisions of Chapter 11 Part IV of the 'Guidelines on Election-related Activities in respect of the Legislative Council Election', organisers of election forums should be aware of the potential for possible instances of harassment of candidates.

5. In order to ensure that order, fairness and impartiality are maintained and to avoid any embarrassment, where a forum is to be held at private premises, prior precautions should be made with the owner, occupier, owners' corporation, building management or the mutual aid committee concerned, to ensure the safety of all participants and the orderly proceeding of the forum. Where necessary, security guards should be employed at the forum venue.

Electioneering at Living or Working Places

6. Chapter 9 of the 'Guidelines on Election-related Activities in respect of the Legislative Council Election' relates to the conduct of electioneering activities at the living or working places of electors, etc.

7. If a decision is made by the owners or owners' corporations to allow electioneering by candidates, the decision can also set out the hours of access and other conditions. These conditions can also minimise the potential for confrontation and the harassment of candidates.

8. Related to this, candidates should be sensitive to the feelings of tenants, occupiers and owners in planning and carrying out electioneering activities. By doing so, they will ensure that such activities can be carried out in a safe and orderly manner.

9. In addition to obtaining the formal approval or consent of the owners or the owner's corporation which have right to control or manage the common parts of the building to conduct electioneering activities in the building, it is advisable for the candidates to notify the management office at the time that the electioneering activities are being carried out.

General

10. Should any safety issues be of particular concern, consideration should be given to seeking advice from the local police station, prior to the conduct of the activity.

[Amended in October 2007 and June 2016]

Application for a Permit under S4(17)
of Summary Offences Ordinance, Cap.228
for Non-Charitable Purposes

This application should reach Division III of Home Affairs Department at 30/F, Southorn Centre, 130 Hennessy Road at least **FOUR WEEKS** before the date of the activity. This will enable the applicant to be notified of the result of his application about seven days before the event. Non-charitable fund raising activities without permits for fund-raising for non-charitable purposes are subject to prosecution by the Police under S4(17) of Summary Offences Ordinance, Cap.228. For enquiries, please call 2835 1492.

1. Name of applicant : * Mr/Mrs/Miss/Ms _____

Name in Chinese (if any) : _____

2. Hong Kong Identity Card Number : _____

(Please enclose a photocopy of your Hong Kong Identity Card)

3. Address : _____

4. Contact Telephone No. : _____ Fax No. : _____

5. If this application is made on behalf of an organisation, please complete the following details : -

i) Name of organisation : _____

ii) Position of applicant in organisation : _____

iii) Details of key officers in organisation :

<u>Post</u>	<u>Name</u>	<u>Address</u>
<u>President/Chairman</u>	_____	_____
<u>Secretary</u>	_____	_____
<u>Treasurer/Accountant</u>	_____	_____

iv) Date the organisation was formed : _____

v) Type of organisation : Society registered/exempt under the Societies Ordinance, or
Company incorporated in Hong Kong, or
Others (Please give details)

(Please enclose a copy of the certificate of registration/exemption of your organisation and also a copy of the memorandum and articles of association or the constitution or rules of your organisation whichever is applicable. If your organisation is a company incorporated in Hong Kong, a copy each of a Certificate of Incorporation and Certificate of Existence issued by the Companies Registry should also be produced.)

6. If the money raised is intended to benefit another organisation, please complete the following details : -

i) Name of organisation : _____

ii) Relationship between applicant and that organisation :

iii) Details of key officers in that organisation :

<u>Post</u>	<u>Name</u>	<u>Address</u>
<u>President/Chairman</u>	_____	_____
<u>Secretary</u>	_____	_____
<u>Treasurer/Accountant</u>	_____	_____

iv) Date the organisation was formed : _____

v) Type of organisation : Society registered/exempt under the Societies Ordinance, or
Company incorporated in Hong Kong, or
Others (Please give details)

(Please enclose a copy of the certificate of registration/exemption of the organisation and also a copy of the memorandum and articles of association or the constitution or rules of the organisation whichever is applicable. If the organisation is a company incorporated in Hong Kong, a copy each of a Certificate of Incorporation and Certificate of Existence issued by the Companies Registry should also be produced.)

vi) Has the organisation given consent to the activity being organised by you ? * Yes / No

7. If the applicant is making this application as an individual, please complete the following details : -

i) Date and place of birth : _____

ii) Length of residence in Hong Kong : _____

iii) Are you a permanent resident of Hong Kong ? * Yes / No

8. ✦ Intended use of money to be collected : _____

9. ✦ Format of the activity : _____

10. ✦ Method for money collection (note) : _____

11. ✦ Date and time of the activity listed in priority : _____

(Note : To ensure a fair distribution of venues, dates and frequency of fund-raising among all potential applicants, there could be a restriction on the number of days approved, depending on prevailing circumstances.)

12. ✦ Venue and address : _____

Has permission to use venue been secured ? * Yes / No / Under application / Not applicable

(If the venues are in open public places, please give exact locations and enclose layout plan. Please also indicate where furniture (e.g. table) will be placed, if appropriate.)

✦ If approval is given to this application, the permit issued will specify the details given in these items. It will therefore be to the applicant's own advantage to plan the activity carefully, so as to avoid the need to seek fresh approval later on as a result of any changes to the above details.

13. Details of previous S4(17) application(s) to the Secretary for Home Affairs by the applicant, or the organisations named in 5(i) and 6(i) above, or any of the persons named in 5(iii) and 6(iii) above :

<u>Name of Applicant</u>	<u>Date of Application</u>	<u>Approved or Rejected</u>
_____	_____	_____
_____	_____	_____
_____	_____	_____
_____	_____	_____

14. State here any additional information which the applicant wishes to provide in support of this application (e.g. reasons for requesting that the administrative guidelines or licensing conditions for the issue of permit be waived in whole or in part.)

I declare that to the best of my knowledge and belief, the information supplied by me in this form is true and correct.

Signed : _____
(Applicant)

(Chop of organisation, if applicable) Date : _____

* Delete where applicable

(If there is not enough space in this form for the filling in of the required information, the applicant may provide details on a separate sheet of paper and attach it to the form.)

Note: If the activities concerned involve hawking in public places, please seek advice from the Food and Environmental Hygiene Department (Tel: 2879 5696 or 2309 2085) as to whether a temporary hawker licence is required.

September 2007

Statement of Purpose

Purpose of Collection

The personal data provided by means of this form will be used by Home Affairs Department for the purpose of :

“to exercise functions on fund-raising activities for non-charitable purposes”

Classes of Transferees

2. The personal data you provided by means of this form may be disclosed to other Government bureaux, departments and relevant persons and bodies for the purposes mentioned in paragraph 1 above.

Access to personal data

3. You have a right of access and correction with respect to personal data as provided for in sections 18 and 22 and principle 6 of Schedule 1 of the Personal Data (Privacy) Ordinance. Your right of access includes the right to obtain a copy of your personal data provided by this form.

Enquiries

4. Enquiries concerning the personal data collected by means of this form, including the making of access and corrections, should be addressed to :

Executive Officer
Home Affairs Department
Tel. No. : 2835 1492

Administrative Guidelines and Licensing Conditions
for the issue of Public Fund-raising Permits
for Non-Charitable Purposes

Applications for permission under Section 4(17) of the Summary Offences Ordinance (Cap.228) to raise funds by collection of money or sale or exchange for donations of badges, tokens or similar articles in a public place should, where the funds are to be used for a charitable purpose, be referred to the Director of Social Welfare. Where the funds are to be used for any other purpose, such applications should be referred to the Secretary for Home Affairs.

Non-charitable fund raising activities without permits for fund-raising for non-charitable purposes are subject to prosecution by the Police under S4(17) of Summary Offences Ordinance, Cap.228.

A. Administrative Guidelines for Consideration

When considering an application for a public fund-raising permit under section 4(17) of the Summary Offences Ordinance, the Secretary for Home Affairs will normally wish to be satisfied that : -

- (i) the organisation or group on behalf of which the permit is sought, and the organisation or group to benefit from the collection if different, are, where applicable, properly registered under the laws of Hong Kong;
- (ii) if the applicant is an individual, he should be aged 21 or above, and should either be a permanent resident of Hong Kong within the meaning of the Immigration Ordinance, or have been ordinarily resident in Hong Kong for a minimum of seven years;
- (iii) the funds collected will be used for purposes which would contribute directly or indirectly to the development of representative government in Hong Kong;
- (iv) the fund-raising activity will not cause public order and public safety problems, and will not cause nuisance or harassment to the general public;
- (v) the fund-raising activity should not be held on a morning which is a “flag day” approved by the Director of Social Welfare unless it is to be held in a confined public place;
- (vi) the fund-raising activity should not be held at the same time and in the same venue or its vicinity as a charitable fund-raising

activity;

- (vii) there will be no more than one non-charitable fund-raising activity in the same venue or its vicinity on the same day except where the activities are organised by the same applicant;
- (viii) there will be a fair distribution of venues, dates and frequency of fund-raising among all potential applicants; and
- (ix) the permittee who had breached the conditions stipulated in the permit last granted would not be considered for a new permit unless explanations/justifications have been provided to the satisfaction of the Secretary for Home Affairs.

Each application will be considered on its own merits having regard to the above administrative guidelines.

B. Licensing Conditions

The following conditions will normally be imposed if an application is approved : -

- (i) permission must have been obtained or is likely to be forthcoming from the relevant authorities, including the authority responsible for the management of the venue(s), for the fund-raising activity to be held;
- (ii) the funds collected will not be used to finance any profit-making ventures or activities;
- (iii) the funds collected will be used only in Hong Kong;
- (iv) no person will benefit improperly from the collection;
- (v) the permission given for the fund-raising activity is only valid for the details specified in the permit. If there are any changes to such details, the approval of the Secretary for Home Affairs will be required;
- (vi) the permission given for the fund-raising activity will become null and void if the funds collected are used for purposes other than those specified in the permit;
- (vii) within 90 days after the conclusion of the fund-raising activity, the permittee will cause the money received from the public, less any reasonable expenses incurred, to be applied for the purpose for which the permission is given;

- (viii) if after applying the funds collected as described in (vii) above, there is still a balance left, the permittee will donate the unspent funds to a charitable institution which is exempt from tax under section 88 of the Inland Revenue Ordinance (Cap.112) for charitable purpose;
- (ix) the funds collected will be audited by a qualified accountant arranged by the permittee. A copy of the audited accounts will be submitted to the Secretary for Home Affairs within 90 days after the conclusion of the fund-raising activity. The audited accounts will also be made available to members of the public for inspection upon demand;
- (x) all donations are to be purely voluntary, and that the activity shall not create public order problems or cause nuisance, including excessive noise, or harassment to the general public, and that the manner in which the activity is conducted should not be such as to be likely to produce a reaction generally against public fund-raising activities;
- (xi) during the course of the fund-raising activity, the name of the organisation and a copy of the permit/approval letter should be prominently displayed. Every participant of the activity should also wear a clear and legible badge identifying the name of the participant and the name of the organisation; and
- (xii) children under the age of 14 must not be allowed to take part in the activity. Participation by young persons between the age of 14 - 18 must be entirely voluntary and the prior written consent of parents must be obtained.

The Secretary for Home Affairs may, if a particular application so warrants, impose additional conditions such as those required for the protection of the participants in the fund-raising event, for the preservation of law and order, for crowd control, or for public safety purposes. In specific circumstances, he may waive certain conditions where it appears reasonable for him to do so.

Observations made by the Court in an Election Petition relating to a Television Programme on 2010 Legislative Council By-election

1. A candidate of the 2010 Legislative Council By-election made an election petition relating to a multi-episode television programme which introduced the election platforms of all candidates of the By-election. Due to the airtime constraint, only four candidates were introduced in each episode and the time allocated to each candidate was more or less the same.

2. There were five candidates in the constituency in which the aforesaid candidate contested and the candidate number allocated to him was 5. According to the candidate number, the broadcaster of the television programme mentioned above introduced the first four candidates of that constituency in the same episode, while the aforesaid candidate was covered in the next episode. However, there was no mention in the episode on the first four candidates that there was a remaining candidate in that constituency who would be introduced in the next episode. The Court considered that it was possible that such arrangement might cause misunderstanding to the audience who only watched the former episode that there were only four candidates in the constituency concerned.

3. The EAC considers that the broadcaster should let the audience know: (a) the total number and the names of all candidates in the same constituency in each relevant episode; and (b) the episode which will cover or has covered the candidate(s) who is/are not introduced in the current episode. Such an arrangement will ensure that the audience will be fully aware of the total number of candidates in the same constituency even if they watch only one single episode instead of all episodes on the same constituency and that equal treatment will be given to all candidates concerned.

4. Where appropriate, broadcasters are advised to follow the arrangement set out in para. 3 above when producing multi-episode programmes which are election-related.

[Added in June 2012]

Fair and Equal Treatment of Candidates by the Print Media

1. Fairness and equality will in each case be viewed by the Electoral Affairs Commission with reference to the surrounding circumstances.
2. Practical problems that may be experienced by publishers like limitation of column space and staff resources, and situations such as some candidates who have extensive arguments and opinions on issues of public relevance and those who have none, candidates who have made newsworthy statements or speeches as opposed to those who have not uttered a word, and the difference in status and standing of candidates as public figures, etc., are examples of circumstances against which the criteria of fairness and equality are to be judged.
3. What is important is that practical problems, in general terms without specifics, should not be allowed to be used as pretexts for not giving fair and equal treatment and coverage to all candidates/lists of candidates competing in the same constituency. Merely saying that practical problems gave rise to the selective reporting will be viewed as a lame excuse, but if the other candidates/lists of candidates had been approached and they refused to offer any interview, and this fact is made known in the same article, there can hardly be any suspicion or complaint that the guidelines have been breached.
4. Equal treatment and coverage are not necessarily equal space and equal number of words written on each candidate/list of candidates of the same constituency. It is an idea that has to be examined in all the circumstances of each individual case. Where a candidate says more on a topic and another candidate says less, that can be truthfully and faithfully reported, and no reasonable-minded person will say that that is unequal reporting. Fairness and equality here are in the sense of **equal opportunity** being given to all candidates/lists of candidates competing in the same constituency alike.
5. If there is fair and equal treatment of all candidates/lists of candidates competing in the same constituency in a publication, its editorial line or the personal opinions of the writer on each of the candidates can be freely expressed, insofar as they are fair comments and based on true facts. Any newspaper is at full liberty to express its support for or disapproval of a candidate/list of candidates. The guidelines do not seek to impose any shackle on the expression of such ideas.

[Amended in June 2012]

Application Procedure for the Approval of Float Design

1. All applications in respect of the design of any float to be used in a procession or parade must be made in writing with information on the make, model and registration mark (or vehicle identification number in the case of a brand new vehicle) of the vehicle to be used as a float.

2. The application should be accompanied by 3 copies of a drawing, certified by qualified electrical or mechanical engineers, in minimum A3 size, showing the following details:
 - the float and vehicle outline, side, plan, front and rear view, with all major dimensions (both proposed and original) shown
 - the means of entry/exit to and from the driver's compartment
 - location of mirrors which will enable the driver to view both sides of the float
 - location of exhaust outlets from any internal combustion engines
 - location of any auxiliary power equipment installed
 - means of communication with the passengers on the float
 - location of passengers and support for passengers (seats, handles, etc.) on the float

Applicant's attention is drawn to regulation 53(2) of the Road Traffic (Traffic Control) Regulations (Cap 374G) on requirements for carriage of passengers: No driver of a vehicle on a road shall permit a passenger to travel in any vehicle unless seated in a properly constructed seat secured to the bodywork of the vehicle except –

- (a) where the vehicle is a public service vehicle licensed to carry standing passengers; or
 - (b) where the vehicle is exempted under regulation 53A from this subregulation.
- detailed artwork is **not** required

3. All applications must be made at least **1 month** in advance of the date of the event to:

Engineer (Vehicle Approval and Planning)
Vehicle Safety and Standards Division
Transport Department
Room 3402, Immigration Tower
7 Gloucester Road
Hong Kong
(Contact telephone: 2829 5550
Fax: 2802 7533)

4. If the application is approved in principle (subject to the vehicle inspection results), the applicant will be so advised within 14 days upon the receipt of the application, and also informed of further details of the vehicle inspection.
5. In case the design is considered unacceptable, the applicant should resubmit revised drawings within 1 week's time upon notice.

[Amended in June 2012]

**Observations made by the Court of Final Appeal
in a case touching upon Election Expenses
(FACV No. 2 of 2012)**

Expenses are likely to qualify as “election expenses” if they meet the following five criteria:

1. They have been incurred by or on behalf of a candidate (as such a person is defined under s 2(1) of the ECICO).
2. Having identified the activities or matters to which the relevant expenses relate, such activities or matters are referable to a specific election.
3. Such activities or matters go to the conduct or management of the election, in particular to the machinery of the election.
4. The expenses were incurred for the purpose of promoting the election of the relevant candidate or prejudicing the election of another candidate.
5. The activities or matters financed by the expenses have taken place or occurred either during the election period (as defined in s 2(1) of the ECICO) or during the period when the relevant person was a candidate.

There are two further inquiries as well:

1. The date when the relevant expenses were incurred should be ascertained (although this is not a critical question since election expenses may be incurred before, during or after an election period).
2. In relation to the relevant activities or matters of which the expense may be incurred for more than one purpose, it should be considered whether an apportionment exercise appropriate between election expenses and non-election expenses is necessary.

Notes:

1. If there is any inconsistency or ambiguity between the English version and the Chinese version of this Appendix, the English version shall prevail.
2. If you have doubt as to whether an election expense falls within the criteria as mentioned above or whether an expense should be regarded as an election expense, you should consult your own legal advisor, and any legal fees so incurred will not be regarded as election expenses.

[Added in June 2012 and amended in June 2016]

Items of Expenses which may be Counted towards Election Expenses

(Note: This list is by no means an exhaustive list of items of expenditure which may be counted as election expenses. It only serves to illustrate the common items of such expenses.)

1. Fees and allowances, including travelling expenses, paid to agents and assistants engaged in relation to one's election activities.
2. Costs incurred for meals and drinks for agents and assistants before and on polling day.
3. Costs incurred for design and production of election advertisements such as:
 - (a) banners
 - (b) signboards
 - (c) placards
 - (d) posters
 - (e) handbills
 - (f) publicity pamphlets
 - (g) video and audio recordings
 - (h) electronic messages
 - (i) various forms of literature or publicity material for promoting the election of a candidate or candidates or prejudicing the election of another candidate or candidates.

[Note: Costs incurred for publicity materials to give thanks to electors for their support after the election will not be counted as election expense.]

4. Costs incurred for display and removal of election advertisements including labour charges. If the election advertisements have not been removed by the deadline specified by the EAC, the removal costs for the election advertisements charged by the government departments should also be included.
5. Costs incurred by the relevant authorities for removal of election advertisements displayed without authorisation.
6. Costs incurred for renting space used in connection with the election campaign.
7. Costs of stationery used in connection with the election campaign.

8. Operation/miscellaneous costs in connection with the election campaign, e.g. photocopying, hire of telephone line and fax line. [Note: Election deposit will not be counted as election expense.]
9. Postage for mailing of publicity materials (excluding free mailing service provided by the Government).
10. Costs incurred for the hire of transport in connection with the election.
11. Costs incurred for publicity by vehicles. (Remarks: If vehicle is lent to the candidate by any person(s) without charging the candidate, the candidate is also required to declare the estimated market value of rental of similar vehicles in his/her election return apart from reporting the free service or good as election donation.)
12. Costs of advertisements in media, taxi or other public transport.
13. Costs incurred for election meetings, including venue charges.
14. Costs of T-shirts, armbands, caps, etc. and other identification devices for election agents and assistants.
15. Costs incurred for refurbishing as well as the estimated value of old publicity boards.
16. Costs incurred in the publication by a candidate during the election period (i.e. from the commencement of the nomination period to the day on which a declaration is made under ss 42C or 46 of Cap 542 or s 22C of Cap 541D; or the day on which the polling ends) of a document that gives details of work done by the candidate in the capacity of:
 - (a) the Chief Executive;
 - (b) a member of the Legislative Council, a District Council or the Heung Yee Kuk;
 - (c) the Chairman, Vice-chairman or a member of the Executive Committee of a Rural Committee; or
 - (d) a Rural Representative.
17. Costs incurred by the political body or organisation of the candidate in promoting his/her election. [Note: Costs of meeting where the platform of the political body or organisation is publicised without specific reference to the candidate will not be

counted as election expenses. Separately, for the avoidance of doubt, costs of electioneering activities (e.g. 造勢大會) participated by an uncontested candidate after declaration of the election result in respect of his/her constituency to promote other contested candidates will not be counted as election expenses of the uncontested candidate.]

18. Costs for obtaining legal advice incurred in respect of the management of an election (e.g. where a candidate asks his/her lawyer to vet an election publicity pamphlet to make sure that statements contained in it do not amount to libel). [Note: Fees incurred for obtaining (a) legal advice on the general interpretation/application of the electoral laws including whether a particular item of expense can be regarded as “election expenses” and “election donations”, and (b) professional advice on the apportionment of expenses between purposes related to an election and any other purposes, will not be regarded as election expenses.]
19. Interest incurred from a loan to finance the campaigning activities of a candidate. [In case of an interest-free loan, the interest waived should be declared as an election donation and correspondingly as an election expense. A reasonable amount should be assessed by reference to the market interest rate.]
20. Subsidy of activities organised for promoting one’s candidature is a form of election donation which is counted as election expense (e.g. (a) allowance paid to the workers in the activities organised by political party(ies) for promoting the candidate and/or (b) the sponsorship made by the party(ies) for the said activities).
21. Although some people may not charge the candidate for the goods supplied or work, labour and services rendered (except voluntary services), a reasonable sum estimated for such charges, over any allowance or discount usually given to customers, is an election expense (which is correspondingly an election donation made by these people).
22. Goods given incidental to the provision of voluntary service.
23. Costs for charities undertaken for the purpose of promoting one’s candidature.
24. Costs for any negative publicity launched against one’s opponent.

[Amended in October 2007, June 2012 and June 2016]

Collection of Election Donations

Any person or organisation¹⁹ (including a political party) acting as an agent to solicit, receive or collect election donations for a candidate/list of candidates or some candidates/lists of candidates is advised to:

1. have the prior consent/authorisation of the candidate(s)/list(s) of candidates;
2. set up a dedicated ledger account for receiving and handling the election donations;
3. state the apportionment of the donations between candidates/lists of candidates or other parties if more than one candidate/list of candidates or other parties are involved;
4. comply with all the requirements under the ECICO in respect of election donations as if the donations are received by the candidate(s)/list(s) of candidates direct. For example, if the donation is more than \$1,000, a receipt to the donor by the concerned candidate/list of candidates instead of the agent should be issued to the donor;
5. ensure that clear information is provided to donors so that they are fully aware of the purpose/use of their donations; and
6. apply to the Secretary for Home Affairs for permission if the donations are collected through fund-raising activities in a public place for non-charitable purposes.

On the other hand, while candidates/lists of candidates would not be prohibited to solicit donations on the behalf of political parties or any other organisations, they must make sure that the message is clear enough so that members of the public are adequately advised of the purpose and nature of the donation and would in no circumstances be misled to believe that the donation was solicited and used for the election of the candidates/lists of candidates themselves.

[Added in June 2016]

¹⁹ All costs incurred by the person or organisation during the process of rendering the relevant service to the candidate(s)/list(s) of candidates in this regard should be counted towards election expenses and the relevant requirements governing authorisation of election expenses agents as set out in Chapter 7 must be complied with. If the person renders his/her service for the candidate/list of candidates free of charge, voluntarily, personally and in his/her own time, the service is regarded as "voluntary service" according to section 2 of the ECICO. The candidate/list of candidates is, therefore, not required to include such service costs in his/her/its election expenses (this exemption does not apply to the service rendered by an organisation).

**Guidelines for Mutual Aid Committees
Participating in Electioneering Activities**

1. Chapter 18 of the Electoral Affairs Commission's Guidelines on Election-related Activities in respect of the Legislative Council Election provides that a candidate must obtain the prior written consent from a person or an organisation before using the name or logo of that person or organisation, or a pictorial representation of that person in any of his/her election advertisements or activities as an indication of support from that person or organisation.

2. In this respect, Mutual Aid Committees ("MACs") should comply with the following procedures:

- (a) If the support is to be given to a candidate/list of candidates in the name of the MAC, the written consent should be approved at a general meeting convened in accordance with the Model Rules for the MAC, and signed by the incumbent Chairman of the MAC.
- (b) If the support to a candidate/list of candidates is to be given in the official capacity of an office-bearer of a MAC, that office-bearer should first obtain the approval of the MAC at a general meeting convened in accordance with the Model Rules for the MAC. Otherwise, that office-bearer should be careful not to give any impression or cause misunderstanding that the support in his/her official capacity represents the support of the MAC.
- (c) If the support to a candidate/list of candidates is to be given in the personal capacity of an office-bearer of the MAC and his/her official title will not be mentioned in the election advertisements of the candidate/list of candidates, it will not be necessary for that office-bearer to seek approval from the MAC or its executive committee.

3. All general meetings of the MAC should be convened in accordance with the procedures laid down in the Model Rules for the MAC.

4. Decisions made at the meetings of MACs must be properly recorded and the record must be prominently displayed in the block within 7 days after the meeting.

[Amended in June 2012]

**Guidelines for Candidates on Sending Election Advertisements
to Registered Electors and Authorised Representatives
in the Custody of the Correctional Services Department**

(Note: The following guidelines serve to illustrate some of the articles which, if possessed by electors/authorised representatives (“ARs”) in the custody of the Correctional Services Department (“CSD”), may cause security hazards to prison, and will be rejected if they are mailed to them. The list of articles set out below is by no means exhaustive.)

For security reasons and to maintain good order and discipline of the prison, any electoral advertisements (“EA”) mailed to registered electors/ARs in the custody of the CSD will be subject to security checking and will be refused if the EA falls within any of the following categories:-

Materials

- (a) made of metal or plastic;
- (b) laminated;
- (c) sharp object; or
- (d) coated with powder-like material.

Content/Information

- (a) on how to manufacture arms, ammunition, weapon, explosive, harmful or deleterious substance, intoxicating liquor, or any dangerous drugs within the meaning of the Dangerous Drugs Ordinance (Cap 134);
- (b) depicts, describes or encourages violence in the prison, or the escape by any inmate/prisoner from the prison;
- (c) is of such a nature as to facilitate gambling in the prison, or is otherwise detrimental to the rehabilitation of any of the electors/ARs in the custody of the CSD;
- (d) is of such a nature as to encourage the commission of any offence enumerated in Prison Rules (Cap 234A) or of any criminal offence by any of the electors/ARs in the custody of the CSD;
- (e) is of such a nature as to pose a threat to any individual’s personal safety

- or to the security, good order and discipline of the prison; or
- (f) obscene/indecent.

Size & quantity

- (a) bigger than A4 size; or
- (b) exceptionally bulky.

Remarks: In case of queries, please contact Principal Officer (Penal Operations)3 of CSD at 2582 4023.

Correctional Services Department

January 2015

INDEX

Index

(The numbers indicate paragraph numbers)

a

- action checklist for candidates 1.23, Appendix A
- actors, during election period 11.14-11.15
- address, change of an elector's residential address 2.11-2.14, 3.22-3.24
- admission
 - ballot paper sorting station 5.53-5.55
 - counting station (see also *counting station*)
..... 5.65-5.66, 7.17, 7.48-7.49
 - polling station (see also *polling station*) 5.21-5.23, 7.14, 7.16-7.17, 7.31-7.33
- advance return of election donations (see also *donation*) 16.35-16.37, Appendix A
- advertising
 - through the electronic media 8.1, 11.1
 - through the internet platform 8.4, 8.50-8.53, 8.56, Appendix A, Appendix E
 - through the printing media 8.59, 11.18-11.21
- agent
 - counting (see *counting agent*)
 - election (see *election agent*)
 - election expense (see *election expense agent*)
 - polling (see *polling agent*)
- allocation of designated spots 8.18-8.20, 8.24-8.26, 8.29-8.35
- allocation of polling station (see also *polling station*) 5.12, 7.39
- amplifying device (see also *loud-hailer, loudspeaker, sound amplifying device*)
 - restrictions 5.15-5.16, 9.20, 12.2-12.5, 12.10, 14.10, 14.12
 - sanction by Electoral Affairs Commission ("EAC") 9.20, 12.4, 12.11
 - time restriction 9.20, 12.4
 - vehicles 12.4, 12.6-12.9
- anonymous donations (see also *donation*) 16.21
- appeal against provisional register (see also *provisional register*) 2.19, 3.31
- appeal against the decision of the Court of the First Instance 6.5
- application for registration as an elector (see also *elector*)
..... 2.4-2.5, 2.7-2.10, 3.4-3.15, 3.18-3.21
- appointment
 - counting agent (see also *counting agent*) 7.44-7.45
 - election agent (see also *election agent*) 7.7-7.9
 - election expense agent (see also *election expense agent*)
..... 7.18-7.20, 16.12-16.15, Appendix R
 - polling agent (see also *polling agent*) 7.25-7.27

Arabic numeral (see also <i>ballot paper</i>)	5.33, 5.89-5.90
assistance to incapacitated elector (see also <i>disability of electors</i> and <i>elector</i>)	5.12, 5.29, 5.36-5.37, 7.39-7.41
authorisation of election expense agent (see also <i>election expense agent</i>)	7.18-7.20, 16.12-16.15, Appendix R
authorised representative	
- eligibility for appointment	3.13-3.14
- notice of appointment	3.15
b	
badge, emblem, clothing or head-dress (see also <i>propaganda material</i>)	5.15-5.16, 5.43, 7.36, 7.42, 8.2, 14.10, Appendix G
ballot box	
- colour	Appendix D
- delivery	5.49-5.52, 5.59, 5.61, 5.71, 5.78, 5.82-5.83, 5.85, 7.34
- locking and sealing	
- at the close of poll	5.47, 5.48-5.49, 7.34-7.35
- before commencement of poll	5.17, 7.34-7.35
- opening	5.49, 5.58-5.59, 5.69, 5.82, 7.50-7.51
ballot paper	
- colour	5.7, 5.9, 5.31, Appendix D
- counting	5.62-5.97
- disposal	5.101-5.103
- invalid	5.70-5.73, 5.86-5.93
- marking	5.29, 5.31-5.37, 5.40, 7.34, 7.41
- Arabic numeral	5.33, 5.89-5.90
- chop	5.31-5.35, 5.72-5.73, 5.89-5.91, 7.41, Appendix D
- not to be counted	5.72, 5.75, 5.89, 5.93
- questionable	5.70-5.75, 5.78, 5.86-5.93, 7.50
- removal from polling station	Note under 5.35
- spoiled	5.40, 5.48, 5.50, 5.72, 5.89, 7.34
- tendered	5.41, 5.72, 5.82, 5.89, 7.34
- unissued	5.18, 5.48, 5.50-5.51, 5.59, 7.34
- unused	5.29-5.30, 5.42, 5.48, 5.50, 5.72, 5.89, 7.34
- validity	5.70-5.71, 5.73-5.76, 5.78, 5.86, 5.88-5.94, 5.97
ballot paper account	5.51, 5.59, 5.70-5.71, 5.80, 5.82, 5.84, 5.88
ballot paper sorting station	5.2, 5.18, 5.51, 5.53-5.60, 5.70, 5.71, 5.97, 7.17, 7.44, 7.47-7.53
braille template (see also <i>elector with visual impairment</i>)	5.36, 7.41

breach/non-compliance of Guidelines.....	
.....	1.25-1.26, 8.65, 9.42, 12.11, 13.10, 15.11, 16.59, 17.29, 17.32, 20.1, 20.4, 20.14
bribery (see also <i>corrupt conduct</i>).....	4.5, 4.18, Important Note under 4.36, 17.6, 17.16
broadcasting	
- fair and equal treatment.....	11.3-11.8, 11.12-11.13, 11.19, 11.21-11.24
- no unfair advantage.....	11.6, 11.23
- participation by candidates.....	11.5-11.10, 11.16
- political advertising.....	11.2
- relating to exit poll results.....	15.2
- restrictions on presenters, regular contributors, actors, musicians, singers or other entertainers who are candidates.....	11.14-11.15
by-election (see also <i>Legislative Council</i> and <i>election</i>).....	1.2, 1.24

c

candidate	
- action checklist.....	1.23, Appendix A
- appearing in commercial advertisements.....	11.16-11.17
- attending public functions.....	19.9
- death or disqualification.....	2.27-2.30, 3.39-3.43, 4.1, 4.5-4.6
- definition.....	Important Note under 8.1, Important Note under 11.1, 16.2, Important Note under 19.1
- eligibility.....	4.1-4.4
- false statement (see also <i>false statement</i>).....	16.29-16.34, 16.64, 17.9-17.10, 20.18
- lodging of complaint inside polling station.....	7.43, 20.9
- nomination (see <i>nomination of candidates</i>)	
- open platform for public inspection.....	8.50-8.57, 17.11, 17.14, 18.6, 18.13, Appendix E
- request for re-count of votes.....	5.78-5.81, 5.96, 5.98
- withdrawal.....	4.36
Candidates' Briefing.....	4.58-4.62
canvassing activities	
- in a prison or the premises of a law enforcement agency.....	9.14
- in no canvassing zone.....	5.15-5.16, 7.42, 8.28, 12.10, 14.2, 14.10-14.15, 14.17, 15.8, Appendix G
- involving pupils.....	13.1-13.9
- joint canvassing.....	8.37
- outside a polling station (see also <i>polling station</i>).....	5.3, 5.14-5.16, 12.10, 14.1-14.3, 14.10-14.16, 15.8
- using loudspeaker (see <i>amplifying device</i>)	
- using vehicles.....	10.15, 12.4, 12.6-12.9

cardboard	
- colour	5.7, 5.9, 5.31, Appendix D
censure (see also <i>reprimand</i>)	
- abuse of free postage services	8.97
- breach of time restriction when using loud-hailers	9.20, 12.4
- breach/non-compliance of Guidelines	1.26, 8.61- 8.65, 9.42, 11.25-11.26, 12.11, 13.10, 15.7, 15.11, 17.32, 20.14
- claim of support	17.32
- corrupt and illegal conduct	17.32
- exit poll	15.11
- involving youths of school age	13.2, 13.10
- namedropping	17.32
- opportunity to make representations	20.14
- unauthorised display of election advertisements	8.28, 8.61-8.65, 14.10
- unauthorised electioneering against the decision of an organisation or building	9.16-9.17
- unfair and unequal treatment	9.32, 9.41-9.42, 11.25-11.26
central counting station (see also <i>counting station</i>)	5.1, 5.49, 5.51, 5.59, 5.61, 5.63-5.65, 5.68-5.69, 5.78-5.79, 5.81, 5.83, 5.97-5.100, 7.34, 7.45-7.46, Appendix A
Central Platform for public inspection	8.50-8.53, 8.56-8.57, 17.11, 17.14, 18.6, 18.13, Appendix A, Appendix E
change of an elector's particulars (see also <i>provisional register</i>)	
- other personal particulars (see also <i>elector</i>)	2.11-2.14, 3.22-3.24
- residential address (see also <i>elector</i>)	2.11-2.14, 3.22-3.24
Chief Electoral Officer ("CEO") (see also <i>Registration and Electoral Office ("REO")</i>)	
- authorising other form of delivery of nomination form to Returning Officer ("RO")	4.20, Appendix A
- authorising public officers to enter polling or counting station	5.21, 5.65
- Central Platform maintained by the CEO or a person authorised by the CEO	8.50, Appendix E
- deciding display of election advertisement outside the constituency in which a candidate stands	8.34
- designating polling and counting stations	5.2, 5.12
- keeping sealed packets of documents for safe custody	5.102
- reporting irregularities to EAC	5.67-5.68, 20.11, 20.17
Chief Returning Officer	5.21, 5.54, 5.56, 5.65, 7.6, 7.48, 7.52, 19.2
chop (see also <i>ballot paper</i>)	5.31-5.33, 5.35, 5.72-5.73, 5.89-5.90, 7.41, Appendix D

civil servants (see also <i>Officials under the Political Appointment System</i>)	
- attending public functions	19.1, 19.4-19.9
- civil servants acting as agents for candidates	7.6, 19.2
- supporting electioneering activities of a candidate	7.6, 19.2-19.3
claim of support	8.38, 17.11-17.15, 18.1-18.14
close of poll	2.29-2.30, 3.41-3.42, 5.22, 5.29, 5.47-5.52, 14.7, 15.4
columnist (see also <i>regular columnist, restrictions to contribute articles</i>)	11.20
combined polling arrangements	5.5-5.13, Appendix D
- ballot box	5.6, 5.8, 5.19
- colour cardboard	5.7, 5.9, 5.31, Appendix D
- poll card	5.6-5.7, 5.10, 5.12
commercial advertisements, candidates appearing in	11.16-11.17
common parts of building (see also <i>fair and equal treatment principle</i>)	8.6, 8.22, 9.1, 9.6-9.7, 9.9-9.10, 9.12, 9.24, 9.27, 9.30-9.31, 9.34, Appendix K
communication network/websites	8.4, 8.50
complaints	
- against conduct, behaviour or acts of RO or REO officers	20.5
- against criminal, illegal or corrupt activities	20.2
- containing false statement (see also <i>false statement</i>)	20.18
- duties of the CEO, Presiding Officer (“PROs”), Deputy PROs, Assistant PROs and ROs	20.10-20.11, 20.17
- hotline	20.7, 20.9
- inside polling station	7.43, 20.9-20.10
- obligations of the RO, PRO and the CEO	20.17
- period	20.6
- procedure	20.7-20.10
- processing	20.11-20.15
- relating to breach of Guidelines or Regulation	8.65, 16.59, 17.29, 20.1, 20.4
- relating to display of election advertisements	8.65, 20.14
- report to Chief Executive	20.16
Complaints Committee	9.17, 16.59, 17.29, 20.3-20.5, 20.9, 20.11-20.13, 20.15, 20.17-20.18
conduct at	
- ballot paper sorting station (see also <i>counting agent and ballot paper sorting station</i>)	5.53-5.57
- counting station (see also <i>counting agent and counting station</i>)	5.65-5.71, 7.48-7.53
- polling station (see also <i>polling agent and polling station</i>)	5.24-5.46, 7.35-7.37

consent of support (see also <i>namedropping</i>)	8.15, 8.35, Important Note under 8.78, 8.96, 17.11-17.15, 18.1-18.14
contributor	11.14-11.15
corporate elector (see <i>elector</i>)	
corrupt and illegal conduct	
- election expenses and election donations	7.9, Important Note under 7.13, 7.20, 7.23, 8.3, 16.10-16.11, 16.33, 16.51, 16.61-16.66, 17.19, 17.24
- electioneering and voting	17.9-17.23
- enforcement	1.11
- ICAC, Information booklet	17.2
- non-compliance and sanction (see also <i>censure</i> and <i>reprimand</i>)	17.29-17.34
- penalty	17.4, 17.33-17.34
- power of court to excuse innocent acts	17.25-17.28
corrupt conduct	
- bribery	4.5, 4.18, Important Note under 4.36, 17.6, 17.16
- deception	Note under 5.35, 17.6-17.7
- deface of nomination paper	17.8
- duress	Important Note under 4.36, 17.6-17.7, 17.21-17.22
- election expenses and election donations	16.61-16.66, 17.19, 17.24
- force	Important Note under 4.36, 5.38, 17.6-17.7, 17.21-17.22
- nomination and withdrawal of candidature	17.6-17.8
- penalty	17.4, 17.33-17.34
- treating	10.3, 17.17-17.20
- voting offences	17.23
corruption, ICAC Information booklet (see also <i>corrupt and illegal conduct</i>)	17.2
counting, rules relating to	5.40-5.42, 5.69-5.97
counting agent	
- appointment	7.44-7.45
- civil servants acting as agents	7.6, 19.2
- conduct inside ballot paper sorting station	5.53-5.58, 7.48-7.53
- conduct inside counting station	5.65-5.69, 7.48-7.53
- number	7.4
- qualification	7.5-7.6
- revocation	7.46
- role	7.47
counting of votes	
- process	5.69-5.97
- re-count of votes	5.67, 5.78-5.81, 5.96, 5.98, 5.100
counting officer/staff	5.54, 5.62-5.63, 5.65, 5.84, 5.86, 5.88, 7.6, 7.50, 19.2

counting station	
- admission	5.65-5.66, 7.17, 7.48-7.49
- central counting station (see <i>central counting station</i>)	
- conduct at	5.65-5.71, 7.48-7.53
- conversion of polling station to counting station (see also <i>polling station</i>)	5.1, 5.62
- designation	5.1-5.2
- display of notice of opening of counting station	5.48, 5.62
- display of notice of result (see also <i>result</i>)	5.99-5.100
- main counting station	5.2, 5.51, 5.71
- photographing, filming and recording (video or audio)	5.67
- public area	5.49, 5.54-5.55, 5.65-5.66, 7.34
- public observation	5.62, 5.65
counting zone	5.59-5.60, 5.65, 5.67, 5.84-5.88, 5.93, 5.98
Court of Final Appeal	6.5, Appendix P
Court of First Instance	4.5, 6.3-6.5, 7.23-7.24, 8.66, 16.26, 16.29-16.31, 16.34, 17.25-17.28, Appendix A
court, power to excuse innocent acts	8.66, 16.29-16.32, 17.25-17.28

d

date

- allocation of number to candidates by drawing of lots	4.58
- appeal against provisional register	2.19, 3.31
- application for re-allocation of polling station by elector with a disability	5.12
- application for registration as electors	2.8-2.10, 3.19-3.21
- application period of Nominations Advisory Committees (see also <i>Nominations Advisory Committees</i>)	4.8-4.9, 4.14
- deadline for postage-free election mail to reach addressees before polling day	8.89
- election or polling	1.2
- elector's notice of change of particulars to reach Electoral Registration Officer	2.13, 3.23-3.24
- nomination	4.16
- publication of final registers	2.20, 3.31
- publication of provisional registers and omission lists	2.15-2.16, 3.25-3.29
- sending in material for inclusion in Introduction to Candidates	4.60
- sending poll card	5.10
- suggestions of designated spots to reach the CEO	Note under 8.20
death or disqualification of a candidate	2.28-2.30, 3.39-3.43, 4.1, 4.5-4.6

declaration	
- for using free postage.....	8.94
- omitted printing details.....	8.60
- result of election (see also <i>election</i> or <i>result</i>).....	2.27-2.30, 3.38-3.42, 5.98-5.100
Declaration of Secrecy	
- ballot paper sorting station.....	5.55, 7.48-7.49
- counting station.....	5.66, 7.48-7.49
- polling station.....	5.23, 7.32-7.33, 7.36
dedicated polling station.....	5.1-5.2, 5.4-5.5, 5.13-5.19, 5.21-5.22, 5.28-5.29, 5.39, 5.44-5.45, 5.48, 5.50-5.51, 5.53, 5.58-5.59, 5.62, 5.70-5.71, 5.88, 5.97, 7.4, 7.11, 7.13-7.16, 7.25-7.29, 7.37, 7.42, 7.44, 7.47, 7.51, 14.10, 14.12, 15.6, Appendix A
delivery of ballot box (see also <i>ballot box</i>).....	5.49-5.52, 5.59, 5.61, 5.69, 5.71, 5.78, 5.82-5.83, 5.85, 5.93, 7.34
delivery of return and declaration of election expenses and election donations (see also <i>return and declaration of election expenses and election donations</i>).....	16.26
deposit, consent of support (see also <i>consent of support</i>).....	8.50, 17.11, 18.6, 18.13
deposit, election.....	4.23-4.25, 4.32, Appendix A
deposit, election advertisement with RO (see also <i>election advertisement</i>).....	8.50-8.57, Appendix A, Appendix E
deposit, permission or authorisation to display election advertisement (see also <i>election advertisement</i>).....	8.27, 8.50-8.57, 10.22
deregistration.....	2.7-2.10, 3.18-3.21
designated spots for displaying election advertisement (see also <i>election advertisement</i>).....	4.58, 8.17-8.26, 8.29-8.35, 8.39, Appendix A, Appendix E
determination of	
- no canvassing zone (see also <i>no canvassing zone</i>).....	5.3, 5.15, 14.3-14.9
- no staying zone (see also <i>no staying zone</i>).....	5.3, 5.15, 14.3-14.9
- polling and counting station (see also <i>polling station</i> and <i>counting station</i>).....	5.1-5.2
disability of electors (see also <i>elector</i>)	
- marking of ballot paper.....	5.29, 5.36-5.37, 7.40
- re-allocation of polling station.....	5.12, 7.39
- template (see <i>braille template</i>)	
dismounting of election advertisement (see also <i>election advertisement</i>).....	8.46
display of election advertisement (see also <i>election advertisement</i>).....	4.58, 8.16-8.26, 8.29-8.35, 8.39, Appendix A, Appendix E
disposal of documents and ballot papers.....	5.101-5.103
disposal of election donation (see also <i>donation</i>).....	16.19, 16.21, 16.27

disqualification

- candidate (see also *candidate*).....2.28-2.30, 3.39-3.42, 4.5-4.6, 16.66, 17.33
- elector (see also *elector*).....2.6, 3.16-3.17
- from voting.....2.6, 3.16-3.17

distribution of election advertisement (see *election advertisement*)District Council (second) Functional Constituency (see *functional constituency*)

document that gives the details of the work done (see also *election advertisement*).....
8.7, 8.9, Appendix Q

donation (see also *election donation*)

- advance return.....16.35-16.37, Appendix A
- anonymous.....16.21
- definition.....16.4
- disposal.....16.19, 16.21, 16.27
- in kind.....16.4, 16.18, 16.21, 16.23-16.26
- purpose.....16.4, 16.16-16.17, 16.21, 16.25
- receipt.....16.21, 16.27-16.28, Appendix A
- return (see also *return and declaration of election expenses and election donations*).....16.23-16.28

drawing of lots

- allocation of alphabet or number to candidate.....4.37, 4.58-4.59
- allocation of spots for display of election advertisement...8.25, 8.31, 8.33, 9.34
- allocation of venue for conducting election meeting.....Appendix H
- determination of election result.....2.25-2.26, 3.35-3.36, 5.98-5.100
- occupation of government land (see also *temporary occupation of government land*).....8.47-8.49

duress (see also *force* or *duress*).....
Important Note under 4.36, 13.2, 17.6-17.7, 17.21-17.22

e

election

- by-election.....
 1.2, 1.24, 2.22, 4.5, 4.14, 4.56-4.57, 5.51, 5.53, 5.71, 5.97-5.98, 8.34, 11.7
- date.....1.2
- declaration of result.....2.27-2.30, 3.38-3.42, 5.98-5.100
- general election.....1.2, 1.24, 2.2, 3.2, 4.4-4.5, 4.8, 4.14, 4.56-4.57,
 5.51, 5.53, 5.71, 5.97, 16.10, 16.38, Appendix A, Appendix D, Appendix E
- petition.....6.1-6.4

election advertisement

- Central Platform 8.50-8.53, 8.56-8.57, 17.11, 17.14, 18.6, 18.13, Appendix A, Appendix E
- corrective information 8.52
- definition 8.1-8.9
- deposit with RO 8.50-8.57, Appendix A, Appendix E
- designated spots 4.58, 8.17-8.26, 8.29-8.35, 8.39, Appendix A, Appendix E
 - allocation 4.58, 8.24-8.26
 - outside the constituency in which a candidate stands 8.34
 - re-allocation 8.33
 - suggestions by prospective candidates 8.20
- dismounting 8.46
- distribution 9.1, 9.19, 9.24, 13.4
- document that gives the details of the work done 8.7-8.9, Appendix Q
- guidelines for sending election advertisement to registered electors and authorized representatives in the custody of Correctional Services Department and other law enforcement agencies 8.100, Appendix T
- joint advertisement 8.35-8.36
- mailing
 - free postage
 - addressing 8.85-8.88
 - approval of specimens 8.90-8.91
 - conditions 8.71-8.78
 - make-up 8.79-8.84
 - method of folding 8.83, Appendix F
 - posting arrangement 8.71-8.99
 - segregation of letters 8.93
 - size 8.78, 8.82
 - weight 8.78
- mounting and installation 8.40-8.45
- negative campaigning 16.13
- no canvassing zone 5.15, 8.28
- no display of election advertisement 8.25
- omitted printing details 8.60
- open platform/candidate's platform maintained by the candidate or a person authorised by the candidate 8.50-8.53, 8.56-8.57, 17.11, 17.14, Appendix E
- penalty 8.61-8.65
- permission/authorisation of display 8.16-8.17, 8.21-8.22, 8.32, 8.50, 8.62, 8.66, 8.70
- prejudicing a candidate 8.1-8.4, 8.8-8.9, 8.11-8.12, 8.67

election advertisement (*Cont'd*)

- print media 8.59, 11.18-11.21
- printed election materials 8.58-8.60
- printing/publication details 8.51-8.58
- private spots 8.16-8.19, 8.21-8.22, 8.27-8.29, 8.64, 9.34-9.39
- public inspection 8.50, 8.52-8.53, 8.55, 8.57
- published materials by organisations 8.67-8.70
- quantity 8.14
- relief 8.66
- removal 8.42-8.43, 8.46, 8.52, 8.62-8.63, 8.65
- re-use of old publicity boards 8.38
- roadside railings 8.39
- size 8.39, 8.78, 8.82
- unauthorised display and consequence 8.25, 8.52, 8.62-8.63, 14.11
- unlawful content 8.72

election agent

- appointment 7.7-7.9
- civil servants acting as agents 7.6, 19.2
- lodging of complaint inside polling station 7.43, 20.9
- number 7.4, 7.7
- qualification 7.5-7.6
- request for re-count of votes 5.78-5.80, 5.96
- revocation 7.10-7.11
- role 7.13-7.17

election broadcasting (see *broadcasting*)

election campaigning 10.5, 10.14, 10.21, 11.6, 11.19, 13.9, 16.13

election day (see also *date*) 1.2

election deposit

- amount 4.23
- payment 4.19, 4.23-4.24
- return 4.25

election donation (see also *donation*) 7.6, 7.23, 8.21, 11.18, 16.2, 16.4, 16.16-16.28, 16.31, 16.35-16.38, 16.55-16.56, 16.62-16.63, 17.24, 19.2, Appendix R

election expenses

- corrupt and illegal conduct (see also *corrupt and illegal conduct, corrupt conduct and illegal conduct*) 7.9, Important Note under 7.13, 7.20, 7.23, 8.3, 8.68, 9.38, 16.11, 16.14, 16.33, 16.51, 16.61-16.66, 17.19, 17.24
- definition 8.13, 16.2, 16.3, 16.5, Appendix P
- items also counted 7.20-7.21, 8.3, 8.4, 8.21, 8.38, 8.46, 8.63, 8.97, 9.22, 10.2, 16.7, 16.18-16.25, 17.19, Appendix Q

election expenses (*Cont'd*)

- liability of a candidate 7.9, 7.13, 7.23, 16.15, 16.61, 16.66
- maximum amount 7.19, 7.24, 8.14, 16.9-16.11
- return (see *return and declaration of election expenses and election donations*)
- special features applicable to a list of candidates 16.50-16.57
- who may incur 7.9, 7.13, 7.18, 8.67-8.68, 16.12-16.15, 16.53

election expense agent

- authorisation 7.18-7.20, 16.12-16.15, Appendix R
- cross-authorisation by candidates on a list of candidates .. 7.18-7.20, 16.53-16.54
- civil servants acting as agents 7.6
- illegal conduct 7.22-7.23, 16.61
- number 7.4, 7.18
- qualification 7.5-7.6
- revocation 7.21
- role 7.22, 16.12

election forum 10.1, 11.1, 11.14, 11.20, 11.22-11.24

election meeting

- at private premises 9.1, 10.5-10.7, 10.10, 10.19-10.20
- definition 10.1
- in a public place 10.8-10.18
- liability of candidates 10.4
- notification to the Police 10.8-10.11
- responsibility of organiser 10.12
- safe conduct, guidance note on election-related activities Appendix K

election petition 6.1-6.5

electioneering activities

- at government premises 9.13
- at private premises 9.2
 - declaration to management body 9.39
 - identification of canvassers 9.22
 - management bodies 9.1, 9.23, 9.30-9.40
 - management company 9.9, 9.30-9.39
 - mutual aid committee 9.10, 9.30-9.39
 - notification of decision to RO 9.33
 - owners' committee 9.8-9.9, 9.30-9.39
 - owners' corporation 9.6-9.9, 9.25-9.27, 9.30-9.39
 - owners' right 9.6-9.7, 9.27
 - residents' association 9.10, 9.30-9.39
 - sanction 9.41-9.42
 - tenants' association 9.10, 9.30-9.39

electioneering activities (<i>Cont'd</i>)	
- tenants' right.....	9.5-9.7, 9.25-9.27
- corrupt and illegal conduct (see also <i>corrupt and illegal conduct, corrupt conduct</i> and <i>illegal conduct</i>).....	17.9-17.23
- in public housing estates.....	10.22
- in schools.....	13.8-13.9
- participated by school pupils (see also <i>pupil involvement</i>).....	13.1-13.6
- safe conduct, guidance note on election-related activities.....	Appendix K
- scope.....	9.1
- using loud-hailers (see <i>amplifying device</i>)	
electioneering on television and radio (see also <i>broadcasting</i>).....	11.2-11.7
electioneering exhibition.....	10.21-10.22
elector	
- application for registration/deregistration.....	2.7-2.10, 3.18-3.21
- change of other personal particulars.....	2.11-2.14, 3.22-3.24
- change of residential address.....	2.11-2.14, 3.22-3.24
- corporate elector.....	3.7-3.8, 3.13-3.15, 3.17, 3.21, 3.24-3.25, 5.1, 5.5, 5.10
- disqualification.....	2.6, 3.16-3.17
- eligibility to vote.....	2.3, 3.4
- identification at polling station.....	5.24
- imprisoned or held in custody.....	2.15-2.16, 2.19-2.20, 3.25, 3.27, 3.31-3.32, 4.59, 5.1, 5.4, 5.13, 7.15, 7.27, 8.100-8.101
- qualification for registration	
- as a FC elector.....	3.5-3.12, Appendix B
- as a GC elector.....	2.4-2.5
- visual impairment.....	4.62, 5.36-5.37, 7.40-7.41
- with a disability.....	4.62, 7.39-7.41
Electoral Registration Officer	
- change of personal particulars.....	2.11-2.14, 3.22-3.24
- inquiry.....	2.14, 3.28
- publishing final register.....	2.3, 2.20, 3.32
- publishing provisional register and omissions list.....	2.15-2.17, 3.25-3.29
- registration of electors.....	2.5, 2.8-2.9, 3.15, 3.19-3.21
electronic address of the open platform maintained by a candidate.....	8.50, 8.57
electronic copy of election advertisement and the relevant information/documents.....	8.50-8.53, 8.56-8.57, 17.11, 17.14, 18.13, Appendix E
eligibility	
- nomination of candidates (see also <i>nomination of candidates</i>).....	4.2-4.4
- to vote.....	2.3, 3.4

empty opaque bag.....	2.26, 3.36, Annex to Appendix C
entertainers, during election.....	11.14-11.15
entrance intercom system.....	9.19, 9.21
equal number of first preference votes (see also <i>preferential elimination system</i>).....	3.36, Appendix C
exit poll	
- application.....	15.5-15.6
- approval.....	15.7
- identification of interviewers.....	15.9-15.10
- notice, conducting exit polls.....	15.7
- restrictions.....	15.3-15.4, 15.8-15.10
- sanction (see also <i>censure</i> and <i>reprimand</i>).....	15.11
- secrecy of the vote.....	15.3
- time for publication of result.....	15.4

f

facsimile transmission.....	4.9, 7.8, 7.10, 7.14, 7.19, 7.21, 7.25-7.26, 7.28, 7.45-7.46, 8.2, 14.6-14.7
fair and equal treatment principle	
- common parts of building.....	8.22, 9.1, 9.6-9.7, 9.9-9.10, 9.12, 9.24, 9.27, 9.30-9.31, 9.34, Appendix K
- display of election advertisement at private premises.....	8.22, 9.30-9.31, 9.34
- election broadcasting.....	11.3-11.5, 11.7-11.13
- election forums.....	11.22-11.24
- electioneering activities at private premises.....	9.1-9.3, 9.12-9.13, 9.23-9.39
- electioneering activities in schools.....	13.9
- electronic media.....	11.3-11.17, Appendix M
- print media.....	11.18-11.21, Appendix N
- sanction (see also <i>censure</i> and <i>reprimand</i>).....	9.41-9.42, 11.25-11.26
false claim of support.....	8.38, 17.11-17.15, 18.1-18.10, 18.12-18.14
false statement	
- about a candidate.....	4.22, 17.9-17.10
- about a complaint.....	20.18
- in return and declaration of election expenses and election donations.....	16.29-16.34, 16.64, 17.27-17.28
- of withdrawal of candidature.....	17.9-17.10
- penalty.....	16.64, 17.33, 20.18

filming inside

- ballot paper sorting station (see also *ballot paper sorting station*).....5.56
- counting station (see also *counting station*).....5.67
- polling station (see also *polling station*).....5.46, 7.42

final register

- abuse or misuse of information.....
..... Important Note under 2.20, Important Note under 3.32
- contents.....2.20, 3.32
- date of publication.....2.20, 3.32
- exclusion of an elector's name.....2.8, 3.19
- inclusion of an elector's name.....2.8-2.20, 3.19-3.32
- public inspection.....2.20, 3.32
- reflection of changes of electors' particulars.....2.13, 2.20, 3.31-3.32
- validity.....2.20, 3.32

Financial Assistance Scheme

- amount payable.....16.38
- making claims and submission.....16.40-16.43
- payment of claims after verification.....16.48
- recovery of payment.....16.49
- verification of claims.....16.44-16.46
- withdrawal of claims.....16.47

first past the post system

- application.....1.7, 3.33
- drawing of lots.....3.35-3.36
- equality of votes.....3.35-3.36
- marking of ballot papers.....5.33, 7.41
- mechanism.....3.35-3.36

float design.....12.9, Appendix O

force or duress (see also *corrupt conduct*).....
..... Important Note under 4.36, 5.37, 13.2, 17.6-17.7, 17.21-17.22

form

- advance return of election donations.....16.28, 16.36
- authorisation for display/distribution of election advertisements or
electioneering activities at private premises.....8.17
- claim for financial assistance.....16.40
- consent of support.....17.12-17.13, 18.2, 18.12
- corrected information of election advertisements.....8.52
- declaration for posting of election mail.....8.94-8.95
- Declaration of Secrecy (see *Declaration of Secrecy*)
- nomination (see also *nomination of candidates*).....4.17-4.24

form (*Cont'd*)

- notice of appointment of counting agents.....	7.45
- notice of appointment of election agent.....	7.8
- notice of appointment of polling agents.....	7.25
- notice of authorisation of persons to incur election expenses.....	7.19
- notice of posting of election mail.....	8.91
- notice of revocation of appointment of agents... 7.10-7.11, 7.21, 7.28-7.29, 7.46	
- notice of withdrawal of candidature.....	4.36
- notification for public meeting or procession (see also <i>notification to the Police</i>).....	10.9
- notification of decision on electioneering activities in a building.....	9.33
- permission to raise funds.....	10.23, Appendix L
- registration of name and emblem.....	4.43-4.47
- request to print particulars relating to candidates on ballot papers.....	4.40, 4.42
- return and declaration and cross-authorisation.....	16.53, 16.56-16.57
- return and declaration of election expenses and election donations.....	16.26-16.28
- return of election deposit.....	4.25
- standard receipt for election donations.....	16.21, 16.28
free postage of election mail (see <i>election advertisement</i>)	
free publication.....	11.19
functional constituency	
- application for registration/deregistration as an elector.....	3.18-3.21
- authorised representative	
- eligibility for appointment.....	3.13-3.14
- notice of appointment.....	3.15
- composition and electors.....	3.3, Appendix B
- corporate elector.....	3.7-3.8, 3.13-3.15
- counting.....	5.83-5.88
- declaration of result.....	5.98-5.100
- disqualification	
- for nomination as a candidate.....	4.5-4.6
- for registration as an elector.....	3.16-3.17
- eligibility for nomination as a candidate.....	4.2-4.4
- eligibility to vote.....	3.4
- final register.....	3.4, 3.6, 3.19, 3.23, 3.25, 3.27, 3.31-3.32
- nomination	
- form/paper.....	4.18-4.21
- notice.....	4.37
- list.....	4.18

functional constituency (*Cont'd*)

- of candidate.....	4.16-4.21
- omissions list.....	3.27-3.29
- ordinary functional constituency.....	3.12, 3.33, 3.35-3.36
- polling arrangements.....	5.1-5.52, Appendix D
- polling station.....	5.1-5.52
- provisional register.....	3.6, 3.25-3.27, 3.29, 3.31-3.32
- qualification	
- for nomination of candidates.....	4.2-4.4
- for registration as an elector.....	3.5-3.12, Appendix B
- for registration as an authorised representative.....	3.13-3.15, Appendix B
- sorting of ballot papers at ballot paper sorting station.....	5.84-5.85
- special functional constituency (see also <i>special functional constituency</i>).....	1.7, 3.10, 3.12, 3.33-3.34
- subscriber.....	4.18
- voting system for ordinary functional constituency (see also <i>first past the post system</i>).....	3.33, 3.35-3.36
- voting system for special functional constituency (see also <i>preferential elimination system</i>).....	1.7, 3.33-3.34
- voting system for District Council (second) functional constituency (see also <i>list system of proportional representation</i>).....	1.7, 3.33, 3.37-3.38
fund raising activities.....	10.23, Appendix L

g

Gazette of the result (see also *result*)..... 5.99, 6.3, 7.23, 8.46, 16.26

general election (see *election*)

geographical constituency

- application for registration/deregistration as an elector.....	2.7-2.10
- counting.....	5.69-5.82
- declaration of result.....	5.98-5.995
- disqualification	
- for nomination as an candidate.....	4.5
- for registration as an elector.....	2.6
- eligibility for nomination as a candidate.....	4.2, 4.4
- eligibility to vote.....	2.3
- final register.....	2.3, 2.5, 2.8, 2.13, 2.15-2.16, 2.19-2.20
- nomination	
- form/paper.....	4.18-4.21
- list.....	4.18, 4.36, 4.39, 4.41-4.42

geographical constituency (<i>Cont'd</i>)	
- notice	4.37
- of candidates	4.16-4.21
- omissions list	2.16-2.17, 2.19
- polling arrangements	5.1-5.52, Appendix D
- polling station (see also <i>polling station</i>)	2.22, 5.1-5.52
- provisional register	2.5, 2.15-2.17, 2.19-2.20
- qualification for registration as an elector	2.4-2.5
- sorting of ballot papers at ballot paper sorting station	5.58-5.61
- subscriber	4.18, 4.28, 4.32
- voting system (see also <i>list system of proportional representation</i>)	2.21-2.27
<i>h</i>	
hours of poll (see also <i>voting</i>)	5.17
<i>i</i>	
ICAC, Information booklet (see also <i>corrupt and illegal conduct</i>)	17.2
identification of	
- canvassers conducting electioneering activities in a building	9.22
- electors at polling stations (see also <i>elector</i>)	5.24
- interviewers conducting exit poll	15.9-15.10
illegal conduct	
- claim of support	17.11-17.13, 18.1-18.11, 18.14
- court to excuse innocent acts	17.25-17.28
- election expenses exceeding maximum amount	16.11, 16.33, 16.51, 16.61, 17.24
- false or misleading statement about a candidate	4.22, 17.9-17.10
- incurring election expenses without authorisation	7.9, 7.20, 8.63, 8.68, 17.24
- namedropping	18.1-18.14
- penalty	16.61-16.66, 17.4, 17.33, 18.14
- voting offences	17.23
impersonation	5.28, 7.30, 7.35
incapacitated elector (see also <i>disability of electors and elector</i>)	3.15, 5.29, 5.37, 7.39-7.41
Information booklet, ICAC (see also <i>corrupt and illegal conduct</i>)	17.2

information in

- election advertisement (see also *election advertisement*)..... 8.51-8.59
- final register..... 2.20, 3.32
- Introduction to Candidates (see also *Introduction to Candidates*)..... 4.59-4.62
- nomination form..... 4.18
- omissions list..... 2.16-2.17, 3.27-3.29
- poll card..... 5.7, 5.10, 5.12
- provisional register..... 2.15, 3.25-3.26
- return and declaration of election expenses and election donations (see also *return and declaration of election expenses and election donations*).....
..... 7.23, 16.26

Introduction to Candidates

- contents..... 4.58-4.62
- submission of message and photograph to Returning Officer..... 4.60
- to be displayed outside polling station..... 5.14
- to be mailed to electors..... 4.59

invalid ballot paper (see also *ballot paper*)..... 5.70-5.72, 5.86, 5.88-5.89

invalid nomination (see also *nomination of candidates*)..... 4.26-4.35

l

law enforcement agency..... 2.15-2.16, 2.19-2.20, 3.25, 3.27, 3.31-3.32, 4.59, 5.1, 5.4, 5.21, 5.23, 5.28-5.29, 5.44-5.45, 7.32, 7.37, 8.100-8.101, 9.14, 11.25, 14.15

Legislative Council

- by-election (see *election*)
- composition..... 1.3, 1.5-1.6
- function..... 1.1
- general election (see *election*)
- governing legislation on elections..... 1.8-1.20
- term of office..... 1.2

list system of proportional representation

- application..... 1.5, 1.7, 2.21, 3.33
- invalid vote..... 5.70-5.72
- marking of ballot papers..... 5.32-5.33, 7.41
- nomination of candidates..... 2.23
- quota of votes..... 2.24
- remainder votes..... 2.24
- single vote for a list..... 2.24, 3.37
- voting and counting procedures..... 2.24-2.27

locking of ballot box (see also *ballot box*)..... 5.17, 5.48, 5.50, 7.34-7.35

loudspeaker (see *amplifying device*)

m

mailing of election advertisement (see also <i>election advertisement</i>)	8.71-8.99
main counting station (see also <i>counting station</i>)	5.2, 5.18, 5.51, 5.53, 5.59, 5.70-5.71, 7.51
management bodies	9.1, 9.23, 9.30-9.39
management company	9.9, 9.30-9.39
marking of ballot paper (see also <i>ballot paper</i>)	5.29, 5.31-5.37, 5.40, 5.42, 7.34, 7.40-7.41
maximum amount of election expenses (see also <i>election expenses</i>)	1.19, 7.19, 7.24, 8.14, 16.9-16.11, 16.18, 16.33, 16.38, 16.52, 16.61
media	
- print	
- advertisements	8.59, 11.18-11.21
- fair and equal treatment	11.18-11.21, Appendix N
- restrictions on regular columnists	11.20
- reporting (see also <i>broadcasting</i> and <i>election forum</i> and <i>electioneering on television and radio</i>)	11.1, 11.4, 11.10, 11.18-11.19, 11.21, 11.25, Appendix N
- television and radio (see also <i>broadcasting</i> and <i>election forum</i> and <i>electioneering on television and radio</i>)	8.1, 11.1, 11.2-11.17, Appendix M
misconduct	
- in a no canvassing zone or no staying zone	14.15
- in or in the vicinity of ballot paper sorting station	5.57, 7.52
- in or in the vicinity of counting station	5.65, 5.68, 7.52
- in or in the vicinity of polling station	5.43, 5.45, 7.36-7.37
mobile telephone	5.43-5.44, 7.36
mounting and installation of election advertisement (see also <i>election advertisement</i>)	8.31, 8.35, 8.40-8.45
musicians, during election period	11.14-11.15
mutual aid committee	8.2, 8.67, 9.10, 9.30-9.39, 10.19, 10.21, 18.5, Appendix K, Appendix S

n

namedropping	
- form of consent	18.12-18.13
- guidelines for mutual aid committees	18.5, Appendix S
- illegal conduct (see also <i>false claim of support</i> and <i>illegal conduct</i>)	18.1-18.14
- penalty (see also <i>censure</i> and <i>reprimand</i>)	18.14
negative campaigning	16.13

no canvassing zone	
- boundary.....	5.15, 8.28
- canvassing activities allowed/forbidden (see also <i>canvassing activities</i>).....	5.15-5.16, 7.42, 14.10-14.15, 15.8, Appendix G
- designation.....	5.3, 5.15, 14.3-14.5
- notice of declaration.....	5.15, 14.3-14.9
- penalty.....	14.17
- purpose.....	5.15, 14.2
- variation.....	5.3, 14.7-14.9
no display of election advertisement (see also <i>election advertisement</i> and <i>no canvassing zone</i>).....	8.25
no staying zone	
- canvassing activities forbidden.....	5.15-5.16, 14.13-14.15
- designation.....	5.3, 5.15, 14.3-14.5
- notice of declaration.....	5.15, 14.3-14.9
- penalty.....	14.17
- purpose.....	5.15, 14.2
- variation.....	5.3, 14.7-14.9
no unfair advantage principle.....	11.6, 11.23
noise nuisance.....	12.2-12.5
nomination of candidates	
- corrupt conduct.....	17.6-17.8
- disqualifications.....	4.5-4.6
- eligibility.....	4.2-4.4
- false declaration.....	4.22
- form.....	4.17-4.21
- invalid.....	4.26-4.35
- notice of validly nominated candidates.....	4.37
- period.....	4.16
- procedure.....	4.17-4.21
- subscriber.....	4.18, 4.28, 4.32
- validity.....	4.15, 4.26-4.35, 6.4-6.5
- withdrawal.....	4.36
Nominations Advisory Committees	
- application period.....	4.8, 4.14
- application procedure.....	4.8-4.9, 4.14
- composition.....	4.7
- decision.....	4.10-4.13, 4.15
- non-binding effect.....	4.13, 4.15
- power.....	4.10-4.11, 4.14

Nominations Advisory Committees (*Cont'd*)

- scope of work.....	4.8, 4.14
notification to RO regarding electioneering activities in a building.....	9.33
notification to the Police	
- public meeting (see also <i>public meeting</i>).....	10.8-10.12, Appendix K
- public procession (see also <i>public procession</i>).....	10.14-10.18
notice of	
- by-election (see also <i>by-election</i>).....	1.2
- declaration of no canvassing zone (see also <i>no canvassing zone</i>).....	5.15, 14.3-14.9
- general election (see also <i>general election</i>).....	1.2
- result of election (see also <i>counting station and result</i>).....	5.98-5.100
- validly nominated candidates (see also <i>nomination of candidates</i>).....	4.26

o

Officials under the Political Appointment System (see also <i>civil servants</i>).....	19.1, 19.10-19.13
omissions list.....	2.16-2.17, 3.27-3.29
Online Voter Information Enquiry System.....	2.18, 3.30
open platform for public inspection.....	8.50-8.57, 17.11, 17.14, 18.6, 18.13, Appendix E
opening of ballot box (see also <i>ballot box</i>).....	5.49, 5.58-5.60, 5.69, 5.83, 7.50-7.51
ordinarily resided in Hong Kong.....	2.4-2.6, 2.14, 3.23, 4.2, 4.4, 4.18
ordinary functional constituency (see <i>functional constituency</i>)	
owners' committee.....	8.2, 8.67, 9.8-9.9, 9.30-9.40
owners' corporation.....	8.2, 8.67, 9.6-9.9, 9.25-9.27, 9.30-9.39, 10.19, 10.21

p

paging machine.....	5.43-5.44, 7.36
particulars relating to candidates on ballot papers	
- application for registration of name and emblem.....	4.44-4.47
- processing of application.....	4.49-4.54
- registration and de-registration of name and emblem.....	4.55-4.57
- request to print particulars relating to candidates on ballot papers.....	4.39-4.42
- time of application.....	4.48
payment of election deposit (see also <i>election deposit</i>).....	4.19, 4.23-4.24
period for nomination (see also <i>nomination of candidates</i>).....	4.16

permission/authorisation of display	
- display of election advertisement at private premises.....	8.16-8.17, 8.21, 8.32, 8.50
- display of election advertisement on designated spots.....	8.16-8.18, 8.27
personal data privacy, guidance note on electioneering activities.....	9.18-9.19, Appendix I, Appendix J
personal data privacy, nominations of candidates.....	Important Note under 4.18
photograph, Introduction to Candidates.....	4.60
photographing inside	
- ballot paper sorting station (see also <i>ballot paper sorting station</i>).....	5.56
- counting station (see also <i>counting station</i>).....	5.67
- polling station (see also <i>polling station</i>).....	5.46, 7.42
politically appointed officials.....	19.10-19.13
poll card (see also <i>combined polling arrangement</i>)	
- contents.....	5.10
- date of sending.....	5.10
polling agent	
- appointment.....	7.25-7.27
- civil servants acting as agents.....	7.6, 19.2
- conduct inside polling station.....	5.24-5.46, 7.35-7.37
- lodging of complaint inside polling station.....	7.43, 20.9
- number.....	7.4
- qualification.....	7.5-7.6
- revocation.....	7.28
- role.....	7.30, 7.35
polling day (see also <i>date</i>).....	1.2
polling officer/staff.....	5.21-5.22, 5.25, 5.31, 5.35-5.45, 7.35, 7.38, 7.40-7.41, 15.9
polling station	
- admission.....	5.21-5.22, 7.14, 7.16-7.17, 7.31-7.33
- allocation.....	5.12, 7.39
- canvassing activities forbidden.....	5.43, 5.45
- communication with electors inside.....	5.44
- conduct inside.....	5.24-5.46, 7.35-7.37
- conduct outside.....	5.15-5.16, 12.10, 14.10-14.16
- conversion of polling station to counting station (see also <i>counting station</i>).....	5.62
- dedicated polling station (see <i>dedicated polling station</i>)	
- designation.....	5.1-5.2, 5.4, 5.12
- display of notice of conversion from polling station to counting station.....	5.48
- elector with visually impairment (see <i>visual deficiency elector</i>)	

polling station (*Cont'd*)

- functional constituency (see *functional constituency*)
- geographical constituency (see *geographical constituency*)
- persons with a disability.....5.12, 7.39-7.41
- photographing, filming and recording (video or audio).....5.46, 7.42
- re-allocation.....5.12, 7.39
- situated in maximum security prison.....
.....5.17, 5.21-5.22, 5.50, 7.4, 7.13-7.14, 7.26
- small polling station (see *small polling station*)
- special functional constituency (see *special functional constituency*)
- special polling station (see *special polling station*)
- voting compartments.....5.32, 5.35, 5.42, 7.36

posting arrangement of election mail (see *election advertisement*)

posting up an electronic copy of election advertisement and relevant information/
documents.....8.50-8.57, 17.11, 17.14, 18.13, Appendix E

preferential elimination system

- absolute majority of votes.....3.34
- application.....1.7, 3.34
- counting procedures.....5.83-5.86, 5.89-5.96, Appendix C
- definition.....3.34
- equal number of first preference votes.....3.34, Appendix C
- marking of ballot papers.....3.34, 5.32-5.33, 7.41
- preference vote.....3.34, 4.25, 5.33, 5.86, 5.91, Appendix C
- single vote.....3.34
- validity of vote.....3.34, 5.84-5.89

prescribed body.....
.....4.38-4.45, 4.48-4.56, 5.15-5.16, 5.42, 7.36, 11.9, 11.12, 14.10, Appendix G

prescribed person.....4.38-4.42, 4.46-4.55, 4.57, 16.2

presenters of television, radio and movie

- guest presenter.....11.14
- restrictions to appear in a programme.....11.14-11.15

Presiding Officer

- after the close of poll.....5.47-5.52
- assistance to incapacitated elector.....5.37, 7.40
- authorising a person to enter counting station.....5.65
- before commencement of poll.....5.17-5.18
- conduct of a re-count.....5.78-5.81
- conduct of vote counting.....5.67-5.77
- decision on a ballot paper.....5.74-5.76
- decision on re-count of votes.....5.78

Presiding Officer (*Cont'd*)

- keeping order at polling, ballot paper sorting and counting stations..... 5.45, 5.57, 5.67
 - making known and reporting the election result..... 5.78
 - opening of ballot box at ballot paper sorting station..... 5.58-5.60
 - opening of ballot box at counting station..... 5.69, 7.50
 - overseeing main counting station (see also *counting station*)..... 5.71
 - overseeing no canvassing zone..... 14.11, 15.8
 - overseeing small polling station (see also *polling station*)..... 5.50-5.51
 - questioning elector before issuing ballot paper..... 5.27, 7.35
 - recording complaint..... 20.9-20.10
 - regulating number of persons inside polling station..... 5.22, 7.17, 7.31
 - reporting irregularities to the EAC..... 20.11, 20.17
- print media (see also *media*)
- advertising through..... 8.59, 11.18-11.21
 - fair and equal treatment (see also *fair and equal treatment principle*)
..... 11.19-11.21, Appendix N
- printed election materials (see also *election advertisement*)..... 8.58-8.60
- printing/publication details of election advertisement (see also *election advertisement*)
..... 8.58-8.60
- prisoner-electors (see *electors*)
- privacy of electors..... 5.39, 9.18-9.19, Appendix I, Appendix J
- private premises
- display of election advertisement (see also *election advertisement* and *fair and equal treatment principle*)..... 8.16-8.22, 8.27-8.29, 8.64
 - election meeting (see also *election meeting*)..... 10.5-10.10, 10.19-10.20
 - electioneering activities (see also *electioneering activities* and *fair and equal treatment principle*)..... 9.1-9.3, 9.15-9.17, 9.23-9.39
- private spots for displaying election advertisement (see also *election advertisement*)....
..... 8.17, 8.21, 9.34-9.35
- procedure
- complaints (see also *complaints*)..... 20.7-20.10
 - nomination (see also *nomination of candidates*)..... 4.17-4.20
- propaganda material (see also *badge, emblem, clothing or head-dress*).....
..... 5.15-5.16, 5.43, 7.36, 7.42, 8.2, 8.87, 14.10, Appendix G
- provisional register
- abuse or misuse of information..... Important under 2.20, Important under 3.32
 - appeals..... 2.19, 3.31
 - contents..... 2.15, 3.25
 - date of publication..... 2.15, 3.25
 - electors to change particulars..... 2.11-2.14, 3.22-3.24
 - exclusion of an elector's name..... 2.8-2.9, 3.19-3.20, 3.27-3.29, 3.31

provisional register (<i>Cont'd</i>)	
- inclusion of an elector's name	2.8-2.15, 3.18-3.25
- public inspection	2.15, 3.25
public area inside counting station (see also <i>counting station</i>)	5.65-5.66
public function	19.1, 19.4, 19.9
public fund-raising permits (see also <i>fund raising activities</i>)	10.23, Appendix L
public housing estates (see also <i>electioneering activities</i>)	8.29, 10.21-10.22
public inspection	
- central platform	8.50-8.53, 8.55-8.57, 17.11, 17.14, 18.6, 18.13, Appendix A, Appendix E
- copies of authorisation of election expenses agent	7.24
- election advertisement (see also <i>election advertisement</i>)	8.50, 8.52, 8.53, 8.55, 8.57
- final register	2.20, 3.32
- nomination form	4.21
- omission list	2.16, 3.27
- permission or authorisation of display of election advertisements in private spots	8.21, 8.27
- provisional register	2.15, 3.25
- register containing the particulars in respect of the registered names and emblems of prescribed bodies and persons	4.48, 4.55
- return and declaration of election expenses and election donations (see also <i>return and declaration of election expenses and election donations</i>)	7.24, 16.58
- statutory declaration for inadvertent omission of printing details	8.60
- written consent and notices of revocation	18.13
public meeting (see also <i>election meeting</i>)	
- notification	10.8-10.11
- prohibition	10.11-10.12
- responsibility of organiser	10.12
public observation inside counting station (see also <i>counting station</i>)	5.65-5.66
public procession	10.4, 10.14-10.18
- notification to the Police	10.15
public resource	7.6, 16.8, 19.2, 19.13
public statement	1.26, 8.65, 8.97, 9.41, 11.25-11.26, 12.11, 13.10, 15.11, 17.32, 20.14
publish materials/message	8.1-8.9, 8.11-8.12, 8.50, 8.67, 9.19, 17.10, Appendix A, Appendix E
publicity materials	1.21, 8.5-8.6, 9.39, 16.39, 18.8, Appendix Q

pupil involvement

- canvassing activities (see also *canvassing activities*).....13.2-13.9
- sanction (see also *censure* and *reprimand*).....13.2, 13.10
- undue influence (see also *force or duress*).....13.2, 13.4

q

qualification

- authorised representative (see also *authorised representative*).....3.13-3.15
 - counting agent (see also *counting agent*).....7.5-7.6
 - election agent (see also *election agent*).....7.5-7.6
 - election expense agent (see also *election expense agent*).....7.5-7.6
 - elector (see also *elector*)
 - in a functional constituency election.....3.5-3.12
 - in a geographical constituency election.....2.4-2.5
 - polling agent (see also *polling agent*).....7.5-7.6
 - subscriber (see also *subscriber*).....4.18, 4.32
- questionable ballot paper (see also *ballot paper*).....5.73-5.76, 5.90-5.94

r

re-allocation of polling station (see also *polling station*).....5.12, 7.39

recording (video or audio) inside

- ballot paper sorting station (see also *ballot paper sorting station*).....5.56
- counting station (see also *counting station*).....5.67
- polling station (see also *polling station*).....5.46, 7.42

re-count of votes (see also *counting of votes*).....5.78-5.81, 5.96

register

- final register (see *final register*)
- provisional register (see *provisional register*)
- use of information contained.....
.....Important Note under 2.20, Important Note under 3.32

Registration and Electoral Office (see also *Chief Electoral Officer* and *Electoral Registration Officer*)

- inquiry.....2.18, 3.28
- processing application for registration of electors.....
.....2.7-2.10, 2.20, 3.18-3.21, 3.32
- public inspection of registers.....2.15-2.16, 2.20, 3.25, 3.27, 3.32, 4.48
- reporting irregularities to EAC.....20.11

regular columnist, restrictions to contribute articles.....11.20

regular contributor, restrictions to appear in a programme	11.14-11.15
reprimand (see also <i>censure</i>)	
- breach of time restriction when using loud-hailers	9.20, 12.4
- breach/non-compliance of Guidelines	1.26, 8.61-8.65, 9.42, 12.11, 13.10, 15.7, 15.11, 17.32, 20.14
- corrupt and illegal conduct	17.32
- exit poll	15.11
- false claim of support	17.32
- involving youths of school age	13.2, 13.10
- namedropping	17.32
- opportunity to make representations	20.14
- unauthorised display of election advertisements	8.28, 8.65, 14.10
- unauthorised electioneering against the decision of an organisation or building	9.16-9.17
- unfair and unequal treatment	9.32, 9.41-9.42, 11.25-11.26
residents' association	9.10, 9.30-9.39
restricted zone	5.65, 7.36
restrictions on	
- canvassing activities in no canvassing zone and no staying zone	5.3, 5.15-5.16, 7.42, 8.28, 12.10, 14.2, 14.10-14.15, 15.10, Appendix G
- presenters	11.14-11.15
- regular columnists	11.20
- regular contributors	11.14-11.15
- use of loudspeaker (see <i>amplifying device</i>)	
result	
- declaration	2.27-2.30, 3.38-3.42, 5.98-5.100
- notice	5.98-5.100
- publication in Gazette	5.98-5.100
return and declaration and cross-authorisation	16.53-16.57
- alteration	16.54
return and declaration of election expenses and election donations	
- court power to excuse innocent acts	17.25-17.28
- errors	16.29-16.34
- false statements	16.61-16.66
- penalty for non-compliance	16.61-16.66
- public inspection	7.24, 16.58
- requirement	16.26-16.28
- submit	16.26-16.28
return of election deposit (see also <i>election deposit</i>)	4.25

Returning Officer

- allocation of designated spots.....	8.18-8.20, 8.24-8.26,8.29-8.35
- authorising a person to enter polling station for liaison purposes.....	5.21
- authorising a person to enter counting station.....	5.65
- conduct of a re-count.....	5.79-5.80, 5.96
- decision on a ballot paper.....	5.74, 5.88-5.89
- declaration of election result.....	2.28-2.30, 3.38-3.42, 5.94-5.96
- determination and declaration of no canvassing zone and no staying zone.....	5.3, 5.15, 14.3-14.9
- displaying notice of result.....	5.99
- giving notice of place for vote counting.....	5.2
- handling complaints.....	8.65, 20.4, 20.9-20.14
- keeping order at polling and counting stations.....	5.44, 5.65
- opening of ballot box at counting station.....	7.50
- providing sketch maps of polling stations and no canvassing zones.....	8.28
- reporting irregularities to EAC.....	20.11, 20.17
Revising Officer.....	2.19-2.20, 3.31-3.32
revocation	
- counting agent (see also <i>counting agent</i>).....	7.46
- election agent (see also <i>election agent</i>).....	7.10-7.11
- election expense agent (see also <i>election expense agent</i>).....	7.21
- polling agent (see also <i>polling agent</i>).....	7.28
role	
- counting agent (see also <i>counting agent</i>).....	7.47
- election agent (see also <i>election agent</i>).....	7.13-7.17
- election expense agent (see also <i>election expense agent</i>).....	7.22, 16.12
- polling agent (see also <i>polling agent</i>).....	7.30, 7.35
roll-up banner.....	8.2

s

schools, electioneering activities.....	13.8-13.9
- enquiry on information of candidates/lists of candidates.....	13.9
school pupils (see <i>pupil involvement</i>)	
sealing of ballot box (see <i>ballot box</i>)	
secrecy of the vote.....	5.6, 5.23, 5.38, 5.66, 7.32, 7.48-7.49, 15.3-15.4
- exit poll (see also <i>exit poll</i>).....	15.3-15.4
- inside a ballot paper sorting station.....	5.55
- inside counting station.....	5.62, 5.66, 7.48-7.49
- inside polling station.....	5.23, 5.38, 5.66, 7.32

secrecy of voting (see <i>secrecy of the vote</i>)	
short message service	Appendix E, Appendix I
singers, during election period	11.14-11.15
small polling station	5.2, 5.18, 5.50-5.51, 5.70-5.71, 5.88
social media/networking	8.4, 8.50, Appendix A, Appendix E
sound amplifying device/system (see <i>amplifying device</i>)	
special functional constituency (see <i>functional constituency</i>)	
special polling station (see also <i>polling station</i>)	5.2, 5.12, 7.39
spoilt ballot paper (see also <i>ballot paper</i>)	5.40, 5.48, 5.50, 5.72, 5.89, 7.34
statutory relief mechanism/arrangement for errors and false statements	16.29-16.34
surface mail	2.9, 3.20
subscriber (see also <i>nomination of candidates</i>)	
- number required	4.18, 4.32
- qualification	4.18, 4.32-4.33

t

telephone (see <i>mobile telephone</i>)	
template (see <i>braille template</i>)	5.36, 7.41
temporary occupation of government land	8.47-8.49
tenants' association	8.2, 8.67, 9.10, 9.30-9.39
tendered ballot paper (see also <i>ballot paper</i>)	5.41, 5.72, 5.82, 5.89, 7.34
treating (see also <i>corrupt conduct</i>)	10.3, 17.17-17.20
television and radio (see also <i>broadcasting and election forums</i>)	11.1-11.17
types and numbers of agents	7.4

u

undue influence (see also <i>force or duress</i>)	13.2, 13.4, 17.21-17.22
unissued ballot paper (see also <i>ballot paper</i>)	5.18, 5.48, 5.50-5.51, 5.59, 7.34
unused ballot paper (see also <i>ballot paper</i>)	
.....	5.29-5.30, 5.42, 5.48, 5.50, 5.72, 5.88-5.89, 7.34

v

validity	
- ballot paper (see also <i>ballot paper</i>)	
.....	5.70-5.71, 5.73-5.76, 5.78, 5.86, 5.88-5.94
- nomination (see also <i>nomination of candidates</i>)	4.15, 4.26-4.35, 6.4-6.5
vehicles (see also <i>amplifying device</i>)	10.15, 12.3-12.9

video or audio recording inside	
- ballot paper sorting station (see also <i>ballot paper sorting station</i>)	5.56
- counting station (see also <i>counting station</i>)	5.63, 5.67
- polling station (see also <i>polling station</i>)	5.46, 7.42
visual deficiency elector (see also <i>disability of electors and elector</i>)	
- assistance to incapacitated elector	5.37, 7.40
- braille template	5.36, 7.41
- visual impairment	4.62, 5.36-5.37, 7.40-7.41
voluntary service	13.5, 16.4, 16.20, 16.25
voting	
- corrupt conduct (see also <i>corrupt conduct</i>)	17.23
- date (see also <i>date</i> and <i>polling day</i>)	1.2
- disqualification	2.6, 3.16-3.17
- eligibility	2.3-2.5
- empty opaque bag	2.26, 3.36, Annex to Appendix C
- marking of ballot paper (see also <i>ballot paper</i>)	
	3.34, 5.29, 5.31-5.37, 5.72, 5.89, 7.34
- number of vote allowed	2.25, 3.34-3.37
- secrecy (see <i>secrecy of the vote</i>)	
- time (see also <i>hours of poll</i>)	5.10, 5.13, 5.17, 5.29, 5.47
- where	5.1-5.2, 5.4-5.12, 7.39
voting compartment	5.32, 5.35, 5.42, 7.36
voting offences (see also <i>corrupt conduct</i>)	17.23
voting preference (see also <i>corrupt conduct</i>)	17.16-17.17
voting system	
- first past the post (see also <i>first past the post system</i>)	
	1.7, 3.33-3.42, 5.32, 5.88
- list system of proportional representation (see also <i>list system of proportional representation</i>)	1.5, 1.7-1.20, 2.23-2.30, 3.33, 3.36-3.37, 5.32
- preferential elimination system (see also <i>preferential elimination system</i>)	
	1.7, 3.33-3.34, 5.33, 5.86, 7.41, Appendix C
w	
websites of	
- candidates	8.2, 8.4, 8.50, 17.11, 18.13
- ICAC	17.2
- REO	4.17, 4.62, 7.15, 7.27, 17.12, 18.12
withdrawal of candidature (see also <i>candidate, corrupt conduct and false statement</i>)	
	4.18, 4.25, 4.36, 17.6-17.8