

L.N. 63 of 2017

Road Traffic (Traffic Control) (Amendment) Regulation 2017

Contents

Section	Page
1. Commencement	B2625
2. Road Traffic (Traffic Control) Regulations amended.....	B2625
3. Regulation 2 amended (interpretation)	B2625
4. Regulation 10 amended (box junctions).....	B2625
5. Regulation 11 amended (double white lines)	B2629
6. Regulation 12 amended (bus lane).....	B2633
7. Regulation 13 amended (studs).....	B2633
8. Regulation 52 amended (equipment)	B2635
9. Regulation 59 amended (failure to comply with traffic signs and road markings).....	B2637
10. Schedule 1 amended (traffic signs).....	B2637
11. Schedule 2 amended (road markings).....	B2709
12. Schedule 3 amended (light signals)	B2729

Road Traffic (Traffic Control) (Amendment) Regulation 2017

(Made by the Secretary for Transport and Housing under section 11 of
the Road Traffic Ordinance (Cap. 374))

1. Commencement

This Regulation comes into operation on 15 December 2017.

2. Road Traffic (Traffic Control) Regulations amended

The Road Traffic (Traffic Control) Regulations (Cap. 374 sub.
leg. G) are amended as set out in sections 3 to 12.

3. Regulation 2 amended (interpretation)

(1) Regulation 2(1), definition of *traffic lane*—

Repeal

“504, 505, 510, 511, 512, 513,”

Substitute

“503A, 504, 505, 510, 511, 512, 513, 513A,”.

(2) Regulation 2(1)—

Add in alphabetical order

“*left-driving road* (靠左駛道路) means a road that is not a
right-driving road;

right-driving road (靠右駛道路) means the Hong Kong-
Zhuhai-Macao Bridge Hong Kong Link Road;”.

4. Regulation 10 amended (box junctions)

(1) Regulation 10(1)—

Repeal

“subregulation (2)”

Substitute

“subregulations (2) and (3)”.

- (2) Regulation 10(2)(a), after “purpose;”—

Add

“or”.

- (3) Regulation 10(2)(b)—

Repeal

“; or”

Substitute a full stop.

- (4) Regulation 10(2)—

Repeal paragraph (c).

- (5) After regulation 10(2)—

Add

“(3) Subregulation (1) also does not apply to a vehicle driven into a box junction marked in accordance with Figure No. 514 in Schedule 2 if—

(a) where the box junction is on a left-driving road, the vehicle—

(i) is driven from a traffic lane marked with a right turn directional arrow of the type shown in Figure No. 509 in Schedule 2 to a position where the vehicle can conveniently wait to make a right turn; and

(ii) is prevented from being driven out of the box junction by other stationary vehicles in or near the box junction waiting to complete a right turn, or by vehicles moving in the opposite direction; or

- (b) where the box junction is on a right-driving road, the vehicle—
 - (i) is driven from a traffic lane marked with a left turn directional arrow of the type shown in Figure No. 509 in Schedule 2 to a position where the vehicle can conveniently wait to make a left turn; and
 - (ii) is prevented from being driven out of the box junction by other stationary vehicles in or near the box junction waiting to complete a left turn, or by vehicles moving in the opposite direction.”.

5. Regulation 11 amended (double white lines)

- (1) Regulation 11(1)(a)—

Repeal

“501 or 503”

Substitute

“501, 503 or 503A”.

- (2) Regulation 11(2)(a)(i), English text—

Repeal

“his”

Substitute

“that”.

- (3) Regulation 11(2)(a)—

Repeal subparagraph (ii)

Substitute

“(ii) the driver can return to—

- (A) if the carriageway constitutes, or is comprised in, a left-driving road—the left side of the continuous white line with a broken white line before the commencement of continuous double white lines; or
- (B) if the carriageway constitutes, or is comprised in, a right-driving road—the right side of the continuous white line with a broken white line before the commencement of continuous double white lines; and”.

(4) Regulation 11(2)(a)(iii)—

Repeal

“he”

Substitute

“the driver”.

(5) Regulation 11(3)(c)—

Repeal

everything after “subregulation”

Substitute

“(4)—

- (i) if the carriageway constitutes, or is comprised in, a left-driving road—to make a right turn into or out of any road, premises or place adjacent to the carriageway; or
- (ii) if the carriageway constitutes, or is comprised in, a right-driving road—to make a left turn into or out of any road, premises or place adjacent to the carriageway.”.

6. Regulation 12 amended (bus lane)

Regulation 12(4), definition of *permitted user*—

Repeal

“119 or 164”

Substitute

“118A, 119, 119A, 164 or 164A”.

7. Regulation 13 amended (studs)

(1) Regulation 13(2)—

Repeal

everything after “and the”

Substitute

“illuminated colour in either case must be white.”.

(2) After regulation 13(2)—

Add

“(2A) Despite subregulation (2), the illuminated colour may be red if the studs are used to delineate—

- (a) the left edge of a carriageway constituting, or comprised in, a left-driving road; or
- (b) the right edge of a carriageway constituting, or comprised in, a right-driving road.

(2B) Despite subregulation (2), the illuminated colour may be amber if the studs are used to delineate—

- (a) the right edge of a carriageway adjacent to a central reservation where the carriageway constitutes, or is comprised in, a left-driving road; or

(b) the left edge of a carriageway adjacent to a central reservation where the carriageway constitutes, or is comprised in, a right-driving road.

(2C) Despite subregulation (2), the illuminated colour may be green if the studs are used to delineate the edge of any part of a carriageway at a road junction, lay by or passing place.”.

8. Regulation 52 amended (equipment)

(1) Regulation 52(1)—

Repeal

“install and operate on or near a road such equipment as he”

Substitute

“cause or permit to be installed and operated on or near a road any equipment that the Commissioner”.

(2) After regulation 52(1)—

Add

“(1A) A permission under subregulation (1)—

(a) must be in writing; and

(b) may be subject to any condition that the Commissioner considers appropriate and specified in the permission.”.

(3) Regulation 52—

Repeal subregulation (2)

Substitute

“(2) A person must not, without the permission of the Commissioner, move, alter or interfere with any equipment installed under subregulation (1).”.

-
- 9. Regulation 59 amended (failure to comply with traffic signs and road markings)**
- (1) Regulation 59(1)(a)—
Repeal
“128, 129, 130,”
Substitute
“123A, 128, 129, 129A, 130, 130A,”.
- (2) Regulation 59(1)(a)—
Repeal
“162, 165, 166, 167, 168, 169,”
Substitute
“161A, 162, 165, 166, 167, 168, 169, 169A,”.
- (3) Regulation 59(1)(b)—
Repeal
“515, 516, 517,”
Substitute
“513A, 515, 516, 517, 517A,”.
- 10. Schedule 1 amended (traffic signs)**
- (1) Schedule 1, Figure No. 108, after “**RIGHT**”—
Add
“**IF THE DIRECTION OF THE ARROW IS REVERSED**”.
- (2) Schedule 1, Figure No. 118—
Repeal

“NEARSIDE”

Substitute

“LEFT MOST”.

- (3) Schedule 1, English text, Figure No. 118—

Repeal

“LANE THE SUPPLEMENTARY TIME PLATE FIG.”

Substitute

“LANE, THE SUPPLEMENTARY TIME PLATE IN FIGURE”.

- (4) Schedule 1, Chinese text, Figure No. 118—

Repeal

“僅在部分時間內使用巴士綫，則須增加”

Substitute

“巴士綫只在部分時間使用，則須增設”。

- (5) Schedule 1, Figure No. 118—

Repeal

“CENTRE OR OFFSIDE”

Substitute

“MIDDLE OR RIGHT MOST”.

- (6) Schedule 1, English text, Figure No. 118—

Repeal

“SHALL”

Substitute

“IS TO”.

- (7) Schedule 1, after Figure No. 118—

Add

“REGULATORY

FIGURE No. 118A

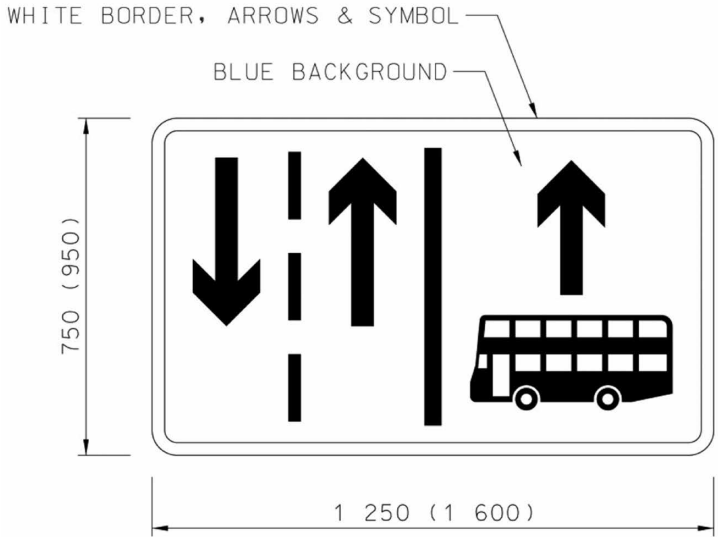

ALL MOTOR VEHICLES EXCEPT FRANCHISED
BUSES PROHIBITED FROM USING RIGHT
MOST LANE

For part time operation of the bus lane, the supplementary time plate in Figure No. 406 will be added.

The number and direction of arrows may be altered to suit the number of lanes available.

The sign may be varied to indicate that motor vehicles except franchised buses are prohibited from using the middle or left most lane.

Where other buses are permitted to use the lane in addition to franchised buses, the symbol in the above sign is to be replaced by “Bus 巴士”.

- (8) Schedule 1, Chinese text, Figure No. 119—

Repeal

“行車綫的”

Substitute

“向前行的行車綫”.

- (9) Schedule 1, English text, Figure No. 119—

Repeal

“SHALL BE REPLACED BY “BUS 巴士””

Substitute

“IS TO BE REPLACED BY “BUS 巴士”.”.

- (10) Schedule 1, Chinese text, Figure No. 119—

Repeal

“該行車綫”

Substitute

“有關的行車綫”.

- (11) Schedule 1, after Figure No. 119—

Add

“REGULATORY

FIGURE No. 119A

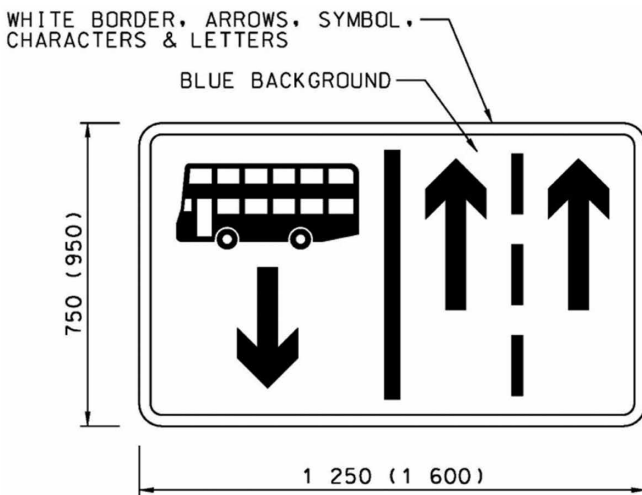
CONTRA-FLOW BUS LANE

To indicate in a one way street a traffic lane reserved for franchised buses proceeding in the opposite direction.

The number of forward arrows may be altered according to the number of forward lanes available to normal traffic.

Where the traffic lane may also be used by other buses, the symbol in the above sign is to be replaced by “Bus 巴士”.

- (12) Schedule 1, Figure No. 122, after “RIGHT”—

Add

“IF THE DIRECTION OF THE SYMBOL AND THE RED DIAGONAL LINE IS REVERSED”.

Section 10

- (13) Schedule 1, Figure No. 123—

Repeal

“PLATES IN FIGURE Nos 417, 420”

Substitute

“PLATE IN FIGURE NO. 417 OR 420”.

- (14) Schedule 1, after Figure No. 123—

Add

“REGULATORY

FIGURE No. 123A

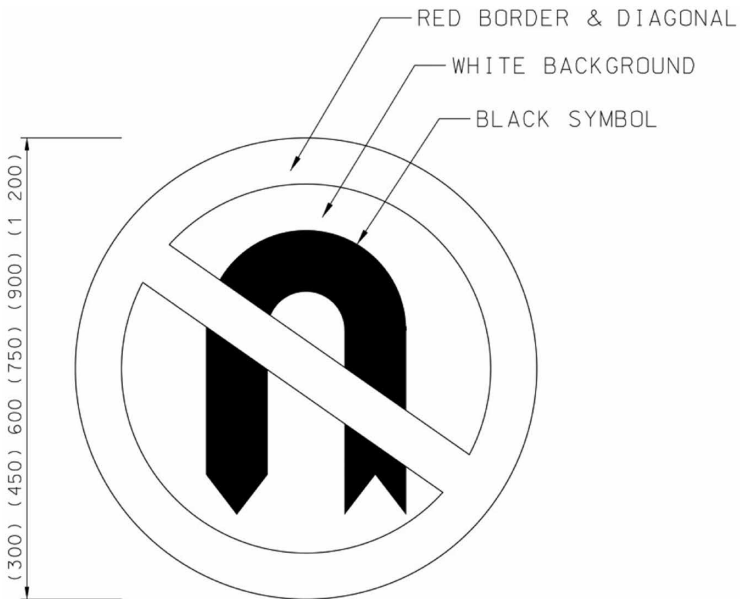

NO-U-TURNS

This sign indicates that the making of U-turns to return in the direction from which one came is prohibited.

This sign may be used in conjunction with traffic signals and the supplementary plate in Figure No. 417 or 420 to indicate the length over which the prohibition applies.”.

- (15) Schedule 1, Chinese text, Figure No. 129—

Repeal

“超車”

Substitute

“越過前車”.

- (16) Schedule 1, Chinese text, Figure No. 129—

Repeal

“超車”

Substitute

“汽車越過前車”.

- (17) Schedule 1, Figure No. 129—

Repeal

“PLATES IN FIGURE Nos. 417, 420”

Substitute

“PLATE IN FIGURE NO. 417 OR 420”.

- (18) Schedule 1, after Figure No. 129—

Add

“REGULATORY

FIGURE No. 129A

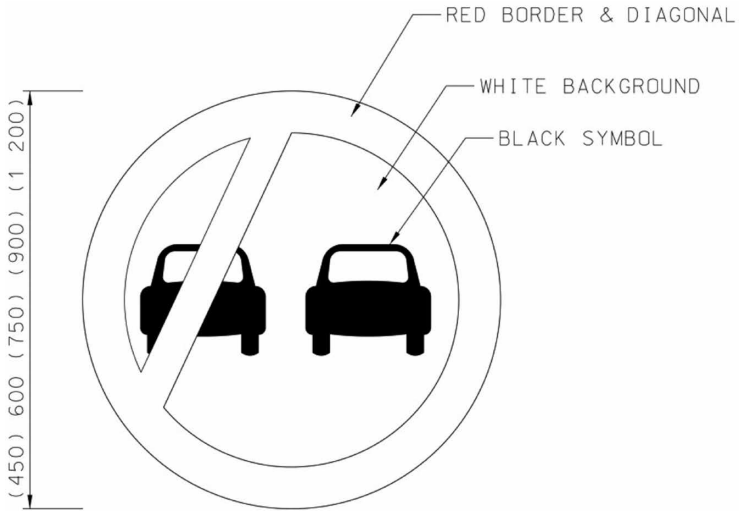

NO OVERTAKING

This sign prohibits the overtaking of motor vehicles.

This sign may be used in conjunction with the supplementary plate in Figure No. 417 or 420.”.

(19) Schedule 1, Figure No. 130—

Repeal

“KEEP TO THE NEARSIDE”

Substitute

“USE THE LEFT MOST”.

(20) Schedule 1, after Figure No. 130—

Add

“REGULATORY

FIGURE No. 130A

KEEP RIGHT

This sign indicates that vehicles must use the right most lane except when overtaking.”.

- (21) Schedule 1, Figure No. 161—

Repeal

“NEARSIDE”

Substitute

“LEFT MOST”.

- (22) Schedule 1, Figure No. 161—

Repeal

“NEARSIDE”

Substitute

“LEFT MOST”.

- (23) Schedule 1, English text, Figure No. 161—

Repeal

“THE SIGN MAY BE USED”

Substitute

“THIS SIGN MAY BE USED”.

- (24) Schedule 1, after Figure No. 161—

Add

“REGULATORY

FIGURE No. 161A

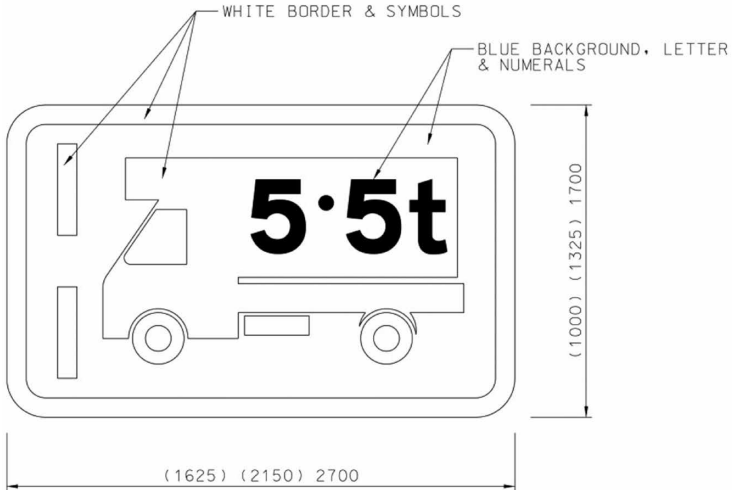

GOODS VEHICLES KEEP TO RIGHT MOST LANE

This sign indicates that goods vehicles with a gross vehicle weight in excess of that indicated must keep to the right most lane within the area covered by the restriction.

The numerals on the sign may be altered to suit different weight limits.

This sign may be used in conjunction with the supplementary plate in Figure No. 417.”.

- (25) Schedule 1, Figure No. 164—

Repeal

“NEARSIDE”

Substitute

“LEFT MOST”.

- (26) Schedule 1, Figure No. 164—

Repeal

“AND/OR “pm” AND “下午””

Substitute

“OR “pm” AND “下午”,”.

- (27) Schedule 1, Chinese text, Figure No. 164—

Repeal

“指明的”

Substitute

“指明”.

- (28) Schedule 1, Figure No. 164—

Repeal

“CENTRE OR OFFSIDE”

Substitute

“MIDDLE OR RIGHT MOST”.

(29) Schedule 1, English text, Figure No. 164—

Repeal

“SHALL”

Substitute

“IS TO”.

(30) Schedule 1, Chinese text, Figure No. 164—

Repeal

“許可”

Substitute

“允許”.

(31) Schedule 1, after Figure No. 164—

Add

“REGULATORY

FIGURE No. 164A

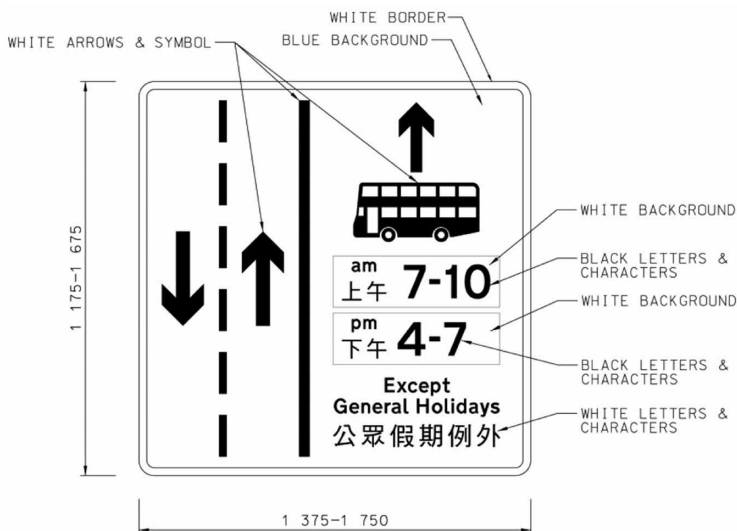

ALL MOTOR VEHICLES EXCEPT FRANCHISED
BUSES PROHIBITED FROM USING RIGHT
MOST LANE

The operation time period may be varied to specify any periods of time or times or in 24-hour time display without the words “am” and “上午” or “pm” and “下午”, and to specify any day or days. “Except General Holidays” and “公眾假期例外” may be deleted for operation on all days.

The number and direction of arrows may be altered to suit the number of lanes available.

The sign may be varied to indicate that motor vehicles except franchised buses are prohibited from using the middle or left most lane.

Where other buses are permitted to use the lane in addition to franchised buses, the symbol in the above sign is to be replaced by “Bus 巴士”.

- (32) Schedule 1, Figure No. 169—

Repeal

“THE SIGN INDICATES THAT VEHICLES MUST KEEP TO THE NEARSIDE”

Substitute

“THIS SIGN INDICATES THAT VEHICLES MUST USE THE LEFT MOST”.

- (33) Schedule 1, after Figure No. 169—

Add

“REGULATORY

FIGURE No. 169A



KEEP RIGHT

This sign is a variation in size of Figure No. 130A.

This sign indicates that vehicles must use the right most lane except when overtaking.”.

- (34) Schedule 1, Chinese text, Figure No. 172—

Repeal

“左綫”

Substitute

“向左”.

- (35) Schedule 1, Chinese text, Figure No. 172—

Repeal

“右綫”

Substitute

“向右”.

- (36) Schedule 1, Figure No. 172—

Repeal

“THE RIGHT-HAND SIDE”

Substitute

“TO THE LANE ON THE RIGHT-HAND SIDE IF THE DIRECTION OF THE ARROW IS REVERSED”.

- (37) Schedule 1, English text, Figure No. 205—

Repeal

“TWO WAY”

Substitute

“TWO-WAY”.

- (38) Schedule 1, Figure No. 205—

Repeal

“TWO WAY TRAFFIC ON THE SAME CARRIAGEWAY WHEN ON THE PREVIOUS SECTION”

Substitute

“TWO-WAY TRAFFIC ON THE SAME CARRIAGEWAY WHEN, ON THE PREVIOUS SECTION,”.

- (39) Schedule 1, English text, Figure No. 205—

Repeal

“ONE WAY”

Substitute

“ONE-WAY”.

- (40) Schedule 1, after Figure No. 205—

Add

“WARNING

FIGURE No. 205A

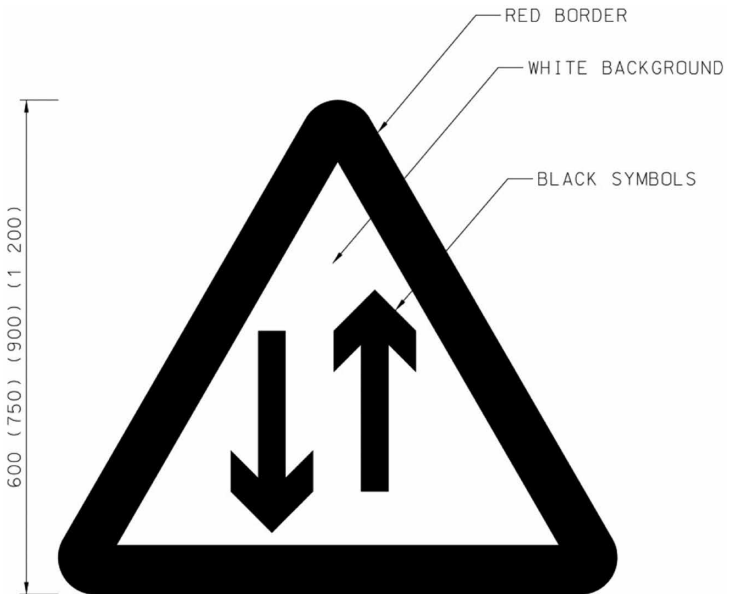
TWO-WAY TRAFFIC

This sign informs road users of the start of a section of the road which is carrying two-way traffic on the same carriageway when, on the previous section, traffic was carried on a road comprising one-way traffic carriageways.”

(41) Schedule 1, Figure No. 206—

Repeal

“TWO WAY”

Substitute

“A ROAD OF TWO-WAY”.

(42) Schedule 1, English text, Figure No. 206—

Repeal

“ONE WAY”

Substitute

“ONE-WAY”.

(43) Schedule 1, English text, Figure No. 206—

Repeal

“IT,”

Substitute

“THE CARRIAGEWAY”.

(44) Schedule 1, after Figure No. 206—

Add

“WARNING

FIGURE No. 206A

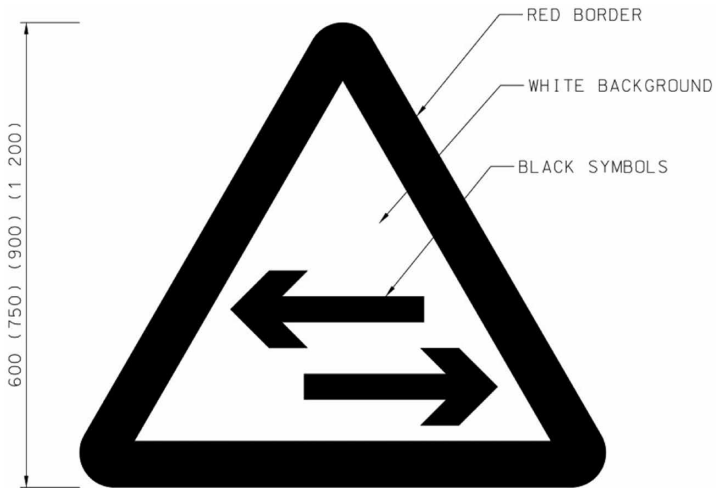

A ROAD OF TWO-WAY TRAFFIC ACROSS A
ONE-WAY CARRIAGEWAY AHEAD

This sign informs road users on a one-way carriageway that they are approaching a road which joins or crosses the carriageway and has two-way traffic.”.

- (45) Schedule 1, Figure No. 217—

Repeal

“PLATES IN FIGURE Nos. 410, 418”

Substitute

“PLATE IN FIGURE NO. 410 OR 418”.

- (46) Schedule 1, after Figure No. 217—

Add

“WARNING

FIGURE No. 217A

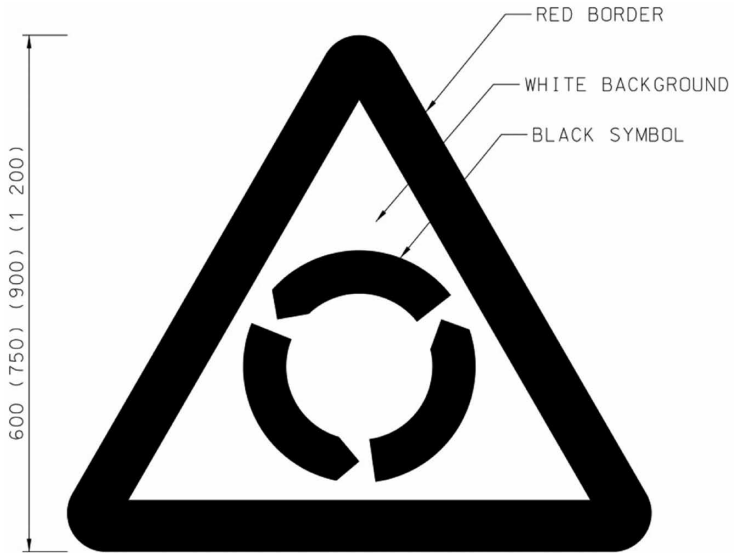

ROUNDABOUT AHEAD

This sign may be used in conjunction with the supplementary plate in Figure No. 410 or 418.”.

- (47) Schedule 1, English text, Figure No. 232—

Repeal

“A SUPPLEMENTARY PLATE IN”

Substitute

“THE SUPPLEMENTARY PLATE IN”.

- (48) Schedule 1, English text, Figure No. 232—

Repeal

“A SUPPLEMENTARY TIME PLATE AS”

Substitute

“, THE SUPPLEMENTARY TIME PLATE”.

- (49) Schedule 1, English text, Figure No. 232—

Repeal

“SHALL” (wherever appearing)

Substitute

“IS TO”.

- (50) Schedule 1, Chinese text, Figure No. 232—

Repeal

“附加”

Substitute

“增設”.

- (51) Schedule 1, Figure No. 232—

Repeal

“NEAR SIDE”

Substitute

“LEFT MOST”.

- (52) Schedule 1, English text, Figure No. 232, after “士”—

Add a full stop.

- (53) Schedule 1, after Figure No. 232—

Add

“WARNING

FIGURE No. 232A

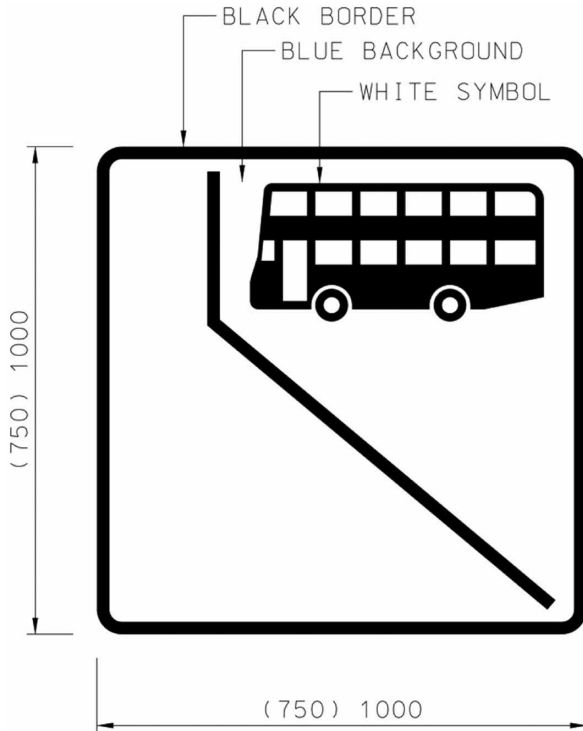

ADVANCE WARNING OF BUS LANE

This sign may be used in conjunction with the supplementary plate in Figure No. 418 to indicate the distance to the start of the bus lane.

For part time operation of the bus lane, the supplementary time plate in Figure No. 406 is to be added.

Where other buses are permitted to use the right most lane in addition to franchised buses, the symbol in the above sign is to be replaced by “Bus 巴士”.

- (54) Schedule 1, Figure No. 233—

Repeal

“LANE THE SUPPLEMENTARY PLATE IN FIGURE No. 406 SHALL BE USED”

Substitute

“LANE, THE SUPPLEMENTARY TIME PLATE IN FIGURE NO. 406 IS TO BE ADDED”.

- (55) Schedule 1, Figure No. 233—

Repeal

“SYMBOLS ON THIS SIGN MAY BE REVERSED OR THE POSITION OF THE ARROWS AND SYMBOL”

Substitute

“THE SYMBOL ON THIS SIGN MAY BE REVERSED OR THE POSITION OF THE ARROWS OR THE SYMBOL MAY BE”.

- (56) Schedule 1, Figure No. 233—

Repeal

“NEAR SIDE”

Substitute

“LEFT MOST LANE OR RIGHT MOST”.

- (57) Schedule 1, English text, Figure No. 233—

Repeal

“SHALL BE REPLACED BY “BUS 巴士””

Substitute

“IS TO BE REPLACED BY “BUS 巴士”.

Section 10

- (58) Schedule 1, Chinese text, Figure No. 236—

Repeal

“須”.

- (59) Schedule 1, after Figure No. 236—

Add

“WARNING

FIGURE No. 236A

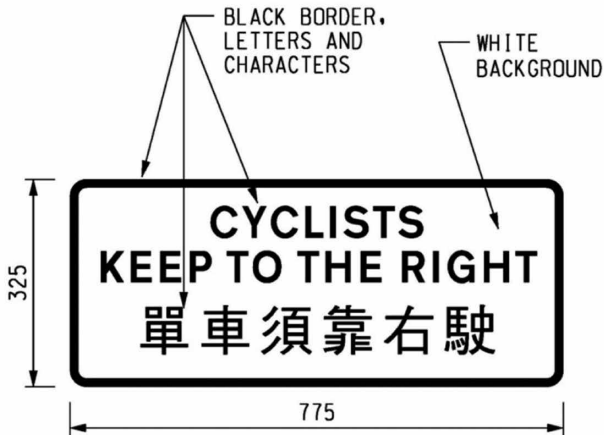

KEEP TO THE RIGHT

This sign may be used to advise cyclists to keep to the right, and may be used on roads where motor vehicles are not permitted or are restricted in use.”.

- (60) Schedule 1, Figure No. 242—

Repeal

“RIGHT LANE”

Substitute

“RIGHT MOST LANE”.

(61) Schedule 1, Figure No. 242—

Repeal

“LEFT LANE”

Substitute

“LEFT MOST LANE”.

(62) Schedule 1, Figure No. 242—

Repeal

“LEFT LANE”

Substitute

“LEFT MOST LANE”.

(63) Schedule 1, Figure No. 242—

Repeal

“LEFT AND RIGHT LANE”

Substitute

“LEFT MOST AND RIGHT MOST LANES”.

(64) Schedule 1, Figure No. 242—

Repeal

“LEFT AND RIGHT”

Substitute

“LEFT MOST AND RIGHT MOST”.

(65) Schedule 1, Figure No. 242—

Repeal

“CENTRE”

Substitute

“MIDDLE”.

(66) Schedule 1, Figure No. 242—

Repeal

“CENTRE”

Substitute

“MIDDLE”.

(67) Schedule 1, English text, Figure No. 242—

Repeal

“ONE WAY”

Substitute

“ONE-WAY”.

(68) Schedule 1, Figure No. 242—

Repeal

“PLATES IN FIGURE NOS. 417, 418, 419 AND”

Substitute

“PLATE IN FIGURE NO. 417, 418, 419 OR”.

(69) Schedule 1, Figure No. 243—

Repeal

“OUTSIDE 2 – LANES”

Substitute

“RIGHT 2 LANES”.

(70) Schedule 1, Figure No. 243—

Repeal

“AND CENTRE”

Substitute

“MOST AND MIDDLE”.

- (71) Schedule 1, Figure No. 243—

Repeal

“INSIDE 2 – LANES”

Substitute

“LEFT 2 LANES”.

- (72) Schedule 1, English text, Figure No. 243—

Repeal

“ONE WAY”

Substitute

“ONE-WAY”.

- (73) Schedule 1, Figure No. 243—

Repeal

“PLATES IN FIGURE NOS. 417, 418, 419 AND”

Substitute

“PLATE IN FIGURE NO. 417, 418, 419 OR”.

- (74) Schedule 1, Figure No. 244—

Repeal

“CENTRE”

Substitute

“MIDDLE”.

- (75) Schedule 1, Figure No. 244—

Repeal

“2-WAY ROAD TO INDICATE THAT THE CENTRE”

Substitute

“TWO-WAY ROAD TO INDICATE THAT THE MIDDLE”.

Section 10

(76) Schedule 1, Figure No. 244—

Repeal

“PLATES IN FIGURE Nos. 417, 418, 419 &”

Substitute

“PLATE IN FIGURE NO. 417, 418, 419 OR”.

(77) Schedule 1, after Figure No. 244—

Add

“WARNING

FIGURE No. 244A

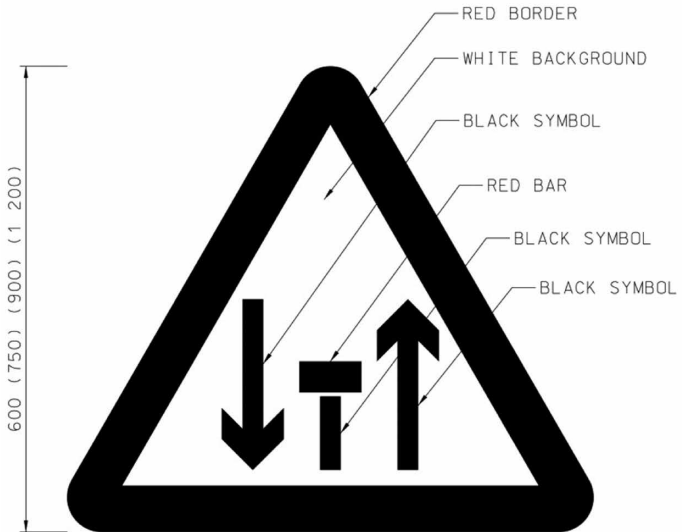

MIDDLE LANE CLOSED AHEAD

This sign is used on a 3-lane two-way road to indicate that the middle lane is temporarily closed.

This sign may be used in conjunction with the supplementary plate in Figure No. 417, 418, 419 or 420.”.

(78) Schedule 1, Figure No. 256—

Repeal everything after the heading “HAZARD MARKER”

Substitute

“These alternative markers may be used to indicate the edge of a carriageway or an obstruction near that edge and—

- (a) the portion of each sign coloured red may be coloured white or amber;
- (b) the signs are to be erected in the immediate vicinity of the carriageway;
- (c) the top of each sign is at least 550 mm and not more than 1 m above the surface of the carriageway in the immediate vicinity;
- (d) if a sign is mounted on a post specially provided for the purpose—
 - (i) the part of the post that extends above ground level is to be coloured black and white in alternate horizontal bands; and
 - (ii) each band must be at least 225 mm and not more than 350 mm in depth;
- (e) if on a carriageway of a left-driving road—
 - (i) the signs are to be erected so that, as viewed by the drivers of approaching vehicles, they display—
 - (A) the colour red on the left edge of the carriageway; and

-
- (B) subject to subparagraph (ii), the colour white on the right edge of that carriageway; and
 - (ii) on the right edge of the central reservation of a dual carriageway, the signs are to be erected so as to display the colour amber instead of the colour white; and
 - (f) if on a carriageway of a right-driving road—
 - (i) the signs are to be erected so that, as viewed by the drivers of approaching vehicles, they display—
 - (A) the colour red on the right edge of the carriageway; and
 - (B) subject to subparagraph (ii), the colour white on the left edge of that carriageway; and
 - (ii) on the left edge of the central reservation of a dual carriageway, the signs are to be erected so as to display the colour amber instead of the colour white.”.
- (79) Schedule 1, Figure No. 311, after “RIGHT”—
- Add**
- “IF THE DIRECTION OF THE SYMBOL IS REVERSED”.
- (80) Schedule 1, Figure No. 312—
- Repeal**
- “HAND”

Substitute

“MOST”.

- (81) Schedule 1, Figure No. 312—

Repeal

“CENTRE”

Substitute

“MIDDLE”.

- (82) Schedule 1, Figure No. 315—

Repeal

“PROCEED TO NEARSIDE”

Substitute

“PROCEED OR KEEP TO LEFT MOST”.

- (83) Schedule 1, Figure No. 315—

Repeal

“NEARSIDE”

Substitute

“LEFT MOST”.

- (84) Schedule 1, English text, Figure No. 315—

Repeal

“SIGN TO”

Substitute

“SIGN IN”.

- (85) Schedule 1, after Figure No. 315—

Add

“INFORMATORY

FIGURE No. 315A

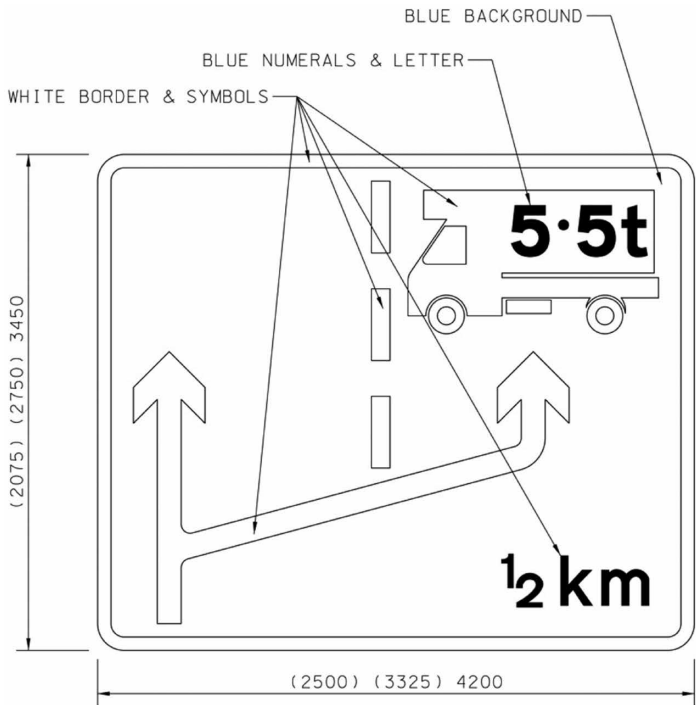

GOODS VEHICLES PROCEED OR KEEP TO RIGHT
MOST LANE

This sign warns drivers of goods vehicles with a gross vehicle weight in excess of the weight indicated that they should proceed or keep to the right most lane before the start of the restriction indicated by the sign in Figure No. 161A.

The numerals on the sign may be altered to suit different weight limits.”.

Section 10

- (86) Schedule 1, Figure No. 316—

Repeal

everything after “316” and before “THIS SIGN”

Substitute



GOODS VEHICLES KEEP TO LEFT MOST LANE
AHEAD”.

- (87) Schedule 1, Figure No. 316—

Repeal

“APPROACHING A MAJOR ROAD THAT THEY SHOULD KEEP IN THE NEARSIDE”

Substitute

“THAT THEY ARE APPROACHING A MAJOR ROAD, AND THAT THEY SHOULD KEEP TO THE LEFT MOST”.

- (88) Schedule 1, English text, Figure No. 316—

Repeal

“SIGN TO”

Substitute

“SIGN IN”.

- (89) Schedule 1, after Figure No. 316—

Add

“INFORMATORY

FIGURE No. 316A

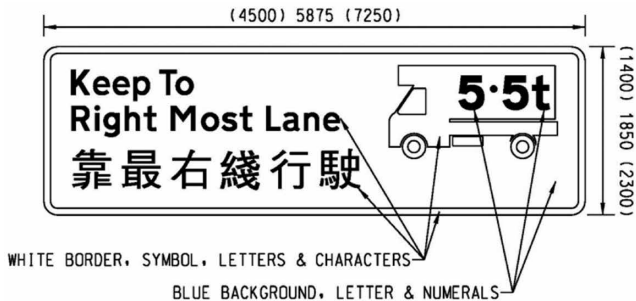

GOODS VEHICLES KEEP TO RIGHT MOST LANE
AHEAD

This sign warns drivers of goods vehicles with a gross vehicle weight in excess of the weight indicated that they are approaching a major road, and that they should keep to the right most lane of the major road before the start of the restriction indicated by the sign in Figure No. 161A.

The numerals on the sign may be altered to suit different weight limits.”.

- (90) Schedule 1, Figure No. 406—

Repeal

“SIGNS IN FIGURE Nos 113, 114, 115, 116, 117, 118, 121, 122, 128, 134, 135, 140, 232,”

Substitute

“SIGN IN FIGURE NO. 113, 114, 115, 116, 117, 118, 118A, 121, 122, 128, 134, 135, 140, 232, 232A OR”.

- (91) Schedule 1, Figure No. 406—

Repeal

“SIGNS APPLY”

Substitute

“SIGN APPLY”.

- (92) Schedule 1, Figure No. 410—

Repeal

“SIGNS IN FIGURE Nos. 204, 208, 209, 211, 212, 217.”

Substitute

“SIGN IN FIGURE NO. 204, 208, 209, 211, 212, 217 OR 217A.”.

- (93) Schedule 1, Figure No. 417—

Repeal

“SIGN FIGURE Nos. 111, 123, 124, 125, 126, 127, 128, 129, 137, 138, 140, 161, 239, 240, 241, 242, 243, 244,”

Substitute

“SIGN IN FIGURE NO. 111, 123, 123A, 124, 125, 126, 127, 128, 129, 129A, 137, 138, 140, 161, 161A, 239, 240, 241, 242, 243, 244, 244A OR”.

- (94) Schedule 1, Figure No. 418—

Repeal

“SIGNS IN FIGURE NOS. 202, 203, 204, 207, 211, 212, 213, 214, 215, 216, 217, 218, 219, 220, 221, 223, 224, 228, 229, 231, 232, 240, 241, 242, 243, 244, 245, 246,”

Substitute

“SIGN IN FIGURE NO. 202, 203, 204, 207, 211, 212, 213, 214, 215, 216, 217, 217A, 218, 219, 220, 221, 223, 224, 228, 229, 231, 232, 232A, 240, 241, 242, 243, 244, 244A, 245, 246 OR”.

- (95) Schedule 1, Figure No. 419—

Repeal

“SIGNS IN FIGURE NOS. 211, 212, 218, 219, 221, 241, 242, 243, 244, 245,”

Substitute

“SIGN IN FIGURE NO. 211, 212, 218, 219, 221, 241, 242, 243, 244, 244A, 245 OR”.

- (96) Schedule 1, Figure No. 420—

Repeal

“SIGNS IN FIGURE NOS. 123, 128, 129, 140, 211, 212, 218, 219, 226, 227, 237, 238, 239, 241, 242, 243, 244,”

Substitute

“SIGN IN FIGURE NO. 123, 123A, 128, 129, 129A, 140, 211, 212, 218, 219, 226, 227, 237, 238, 239, 241, 242, 243, 244, 244A OR”.

- (97) Schedule 1, Figure No. 431—

Repeal

“SIGNS IN FIGURE Nos. 106, 107, 109, 113, 114, 115, 116, 117, 118, 121, 122, 128, 134, 135, 140, 232,”

Substitute

“SIGN IN FIGURE NO. 106, 107, 109, 113, 114, 115, 116, 117, 118, 118A, 121, 122, 128, 134, 135, 140, 232, 232A OR”.

Section 11

(98) Schedule 1, Figure No. 431—

Repeal

“SIGNS APPLY” (wherever appearing)

Substitute

“SIGN APPLY”.

(99) Schedule 1, Figure No. 431—

Repeal

“AND/”.

(100) Schedule 1, Chinese text, Figure No. 431—

Repeal

“指明的”

Substitute

“指明”.

11. Schedule 2 amended (road markings)

(1) Schedule 2, after Figure No. 503—

Add

“REGULATORY

FIGURE No. 503A

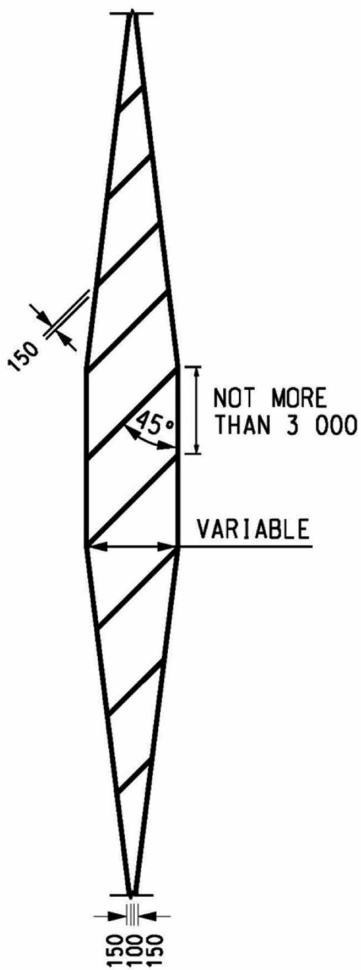

ROAD MARKING

LONGITUDINAL MARKINGS—CONTINUOUS
DOUBLE LINES WITH HATCHING

Continuous double lines and hatched markings to indicate that a vehicle must not be on, over or cross either continuous line contrary to regulation 11.”.

- (2) Schedule 2, English text, Figure No. 513—

Repeal

“SHALL”

Substitute

“MUST”.

- (3) Schedule 2, after Figure No. 513—

Add

“REGULATORY

FIGURE No. 513A

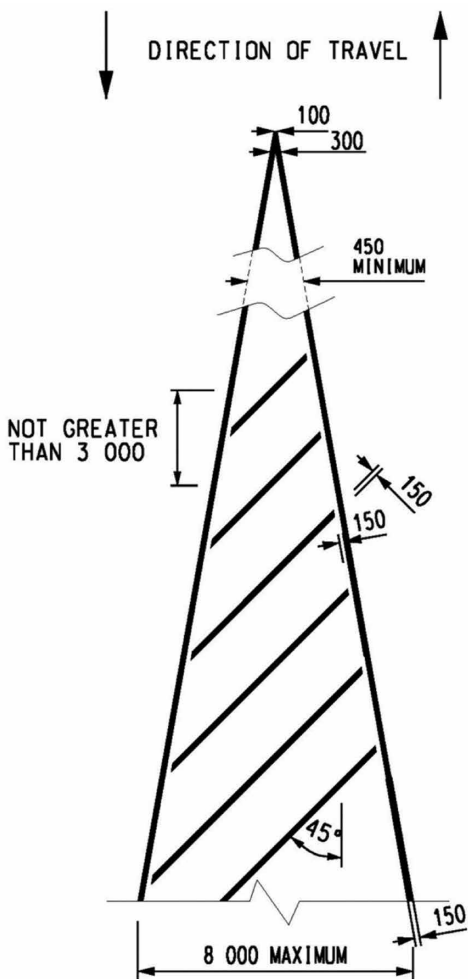

ROAD MARKING
HATCHED TRAFFIC ISLAND MARKING

To indicate to vehicular traffic that part of the carriageway which vehicular traffic must not enter except in emergency.”.

- (4) Schedule 2, English text, Figure No. 517, after “LENGTH OF A BUS STOP”—

Add a full stop.

- (5) Schedule 2, after Figure No. 517—

Add

“REGULATORY

FIGURE No. 517A

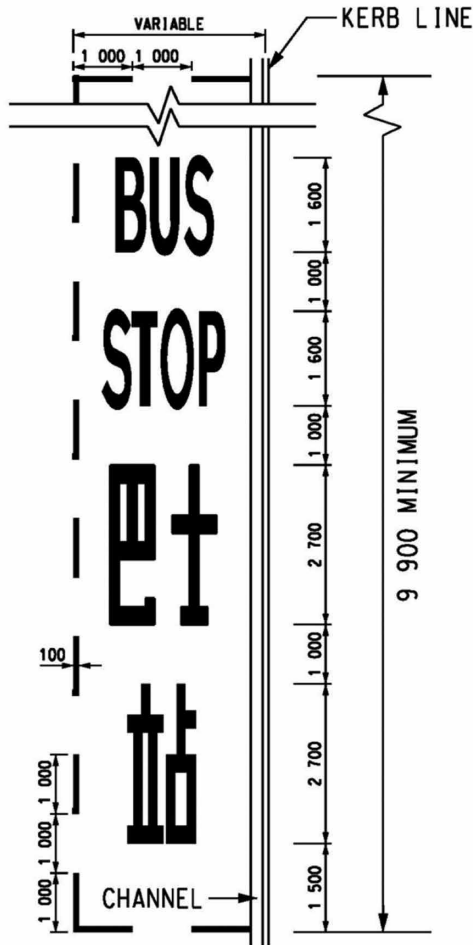

ROAD MARKING

BUS STOP

To indicate to vehicular traffic the limits of a bus stop.

“BUS STOP” and “巴士站” may be repeated according to the length of a bus stop.”.

(6) Schedule 2, Figure No. 610—

Repeal

everything after “610” and before “ROAD”

Substitute

“

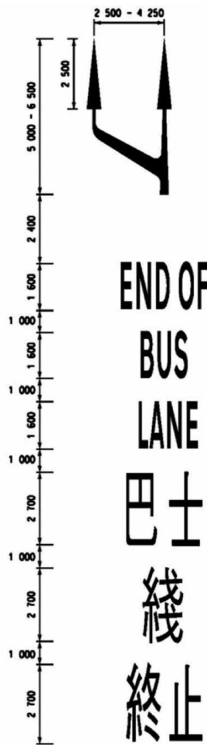

”

- (7) Schedule 2, Figure No. 610—

Repeal

“NEARSIDE LANE. THE”

Substitute

“LEFT MOST LANE.

THE”.

- (8) Schedule 2, after Figure No. 610—

Add

“INFORMATORY

FIGURE No. 610A

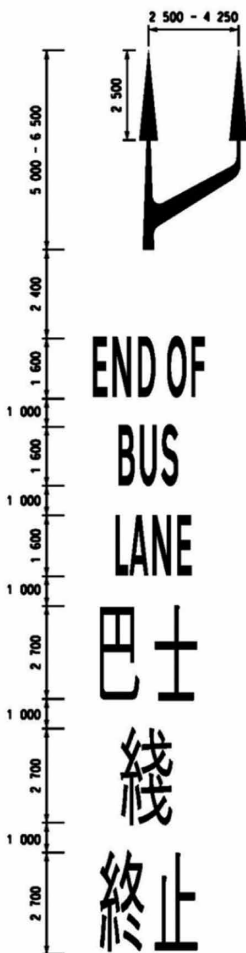

ROAD MARKING
END OF BUS LANE

To indicate to vehicular traffic the end of a bus lane and that they may enter the right most lane.

The marking may be used with or without the letters and characters.”.

- (9) Schedule 2, after Figure No. 611—

Add

“INFORMATORY

FIGURE No. 611A

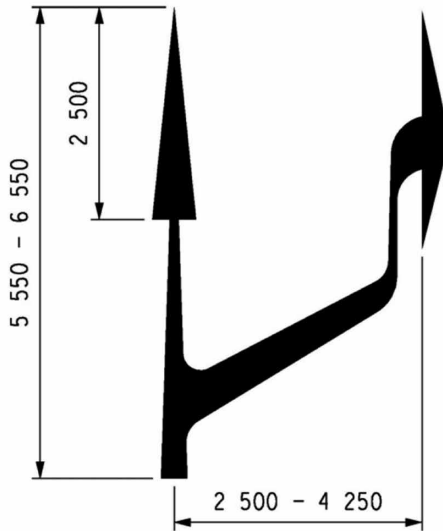

ROAD MARKING

To indicate to vehicular traffic in accordance with regulation 12 that they may enter the traffic lane reserved for buses, but only for the purpose of turning right at the junction ahead.”.

12. Schedule 3 amended (light signals)

Schedule 3, paragraph 2—

Repeal subparagraph (b)

Substitute

- “(b) the lights must be arranged either vertically or horizontally;
- (ba) if the lights are arranged vertically—
- (i) the lamp showing a red light must be uppermost; and
 - (ii) the lamp showing a green light must be lowermost;
- (bb) if the lights are arranged horizontally on a carriageway of a left-driving road, the lights as viewed by the drivers of approaching vehicles must be such that—
- (i) the lamp showing a red light is nearest to the right-hand side of the carriageway; and
 - (ii) the lamp showing a green light is nearest to the left-hand side of the carriageway;
- (bc) if the lights are arranged horizontally on a carriageway of a right-driving road, the lights as viewed by the drivers of approaching vehicles must be such that—
- (i) the lamp showing a red light is nearest to the left-hand side of the carriageway; and
 - (ii) the lamp showing a green light is nearest to the right-hand side of the carriageway;”.

Anthony B. L. CHEUNG
Secretary for Transport and
Housing

18 April 2017

Explanatory Note

This Regulation amends the Road Traffic (Traffic Control) Regulations (Cap. 374 sub. leg. G)—

- (a) to provide for certain traffic signs and road markings for the Hong Kong-Zhuhai-Macao Bridge Hong Kong Link Road;
- (b) to empower the Commissioner for Transport to cause or permit another person to install and operate on or near a road any equipment that the Commissioner considers necessary for collecting information on vehicle and pedestrian movements, and controlling and guiding vehicles; and
- (c) to make consequential amendments.